



The SST12LP08 is a versatile power amplifier based on the highly-reliable InGaP/GaAs HBT technology. Easily configured for linear high-power applications with excellent power-added efficiency while operating over the 2.4- 2.5 GHz frequency band, it typically provides 30 dB gain with 34% power-added efficiency, while meeting 802.11b/g spectrum mask at 23.5 dBm. The SST12LP08 also features easy board-level usage along with high-speed power-up/down control through a single combined reference voltage pin and is offered in both 12-contact XQFN and 6-contact XSON packages.

Features

- **High Gain:**
 - Typically 30 dB gain across 2.4~2.5 GHz over temperature 0°C to +85°C
- **High linear output power:**
 - >28 dBm P1dB
 - Please refer to “Absolute Maximum Stress Ratings” on page 6
 - Meets 802.11g OFDM ACPR requirement up to 23.5 dBm
 - ~3% added EVM up to 20 dBm for 54 Mbps 802.11g signal
 - Meets 802.11b ACPR requirement up to 23.5 dBm
- **High power-added efficiency/Low operating current for both 802.11g/b applications**
 - ~34%/200 mA @ $P_{OUT} = 23.5$ dBm for 802.11b/g
- **Single-pin low I_{REF} power-up/down control**
 - $I_{REF} < 2$ mA
- **Low idle current**
 - ~85 mA I_{CQ} for 12-contact XQFN
 - ~65 mA I_{CQ} for 6-contact XSON
- **High-speed power-up/down**
 - Turn on/off time (10%- 90%) <100 ns
 - Typical power-up/down delay with driver delay included <200 ns
- **Low Shut-down Current (~2 μ A)**
- **High temperature stability**
 - ~1 dB gain/power variation between 0°C to +85°C
- **Excellent On-chip power detection**
- **20 dB dynamic range on-chip power detection**
- **Simple input/output matching**
- **Packages available**
 - 12-contact XQFN – 2mm x 2mm
 - 6-contact XSON – 1.5mm x 1.5mm
- **All non-Pb (lead-free) devices are RoHS compliant**

Applications

- WLAN (IEEE 802.11b/g/n)
- Home RF
- Cordless phones
- 2.4 GHz ISM wireless equipment



Product Description

The SST12LP08 is a versatile power amplifier based on the highly-reliable InGaP/GaAs HBT technology.

The SST12LP08 can be easily configured for high-power applications with good power-added efficiency while operating over the 2.4- 2.5 GHz frequency band. It typically provides 30 dB gain with 34% power-added efficiency (PAE) @ POUT = 23.5 dBm for 802.11b/g.

The SST12LP08 has excellent linearity, typically ~3% added EVM at 20 dBm output power which is essential for 54 Mbps 802.11g operation while meeting 802.11g spectrum mask at 23.5 dBm.

The SST12LP08 can also be easily configured for high-efficiency operation, typically ~3% added EVM at 18 dBm output power and 95 mA total power consumption for 54 Mbps 802.11g applications. High-efficiency operation is desirable in embedded applications, such as in hand-held units, where SST12LP08 can provide 30 dB gain and meet 802.11b/g spectrum mask at 22 dBm output power with 34% PAE.

The SST12LP08 also features easy board-level usage along with high-speed power-up/down control through a single combined reference voltage pin. Ultra-low reference current (total I_{REF} ~2 mA) makes the SST12LP08 controllable by an on/off switching signal directly from the baseband chip. These features coupled with low operating current make the SST12LP08 ideal for the final stage power amplification in battery-powered 802.11b/g/n WLAN transmitter applications.

The SST12LP08 has an excellent on-chip, single-ended power detector, which features wide-range (>15 dB) with dB-wise linearization. The excellent on-chip power detector provides a reliable solution to board-level power control.

The SST12LP08 is offered in both 12-contact XQFN and 6-contact XSON packages. See Figure 3 for pin assignments and Tables 1 and 2 for pin descriptions.



Functional Blocks

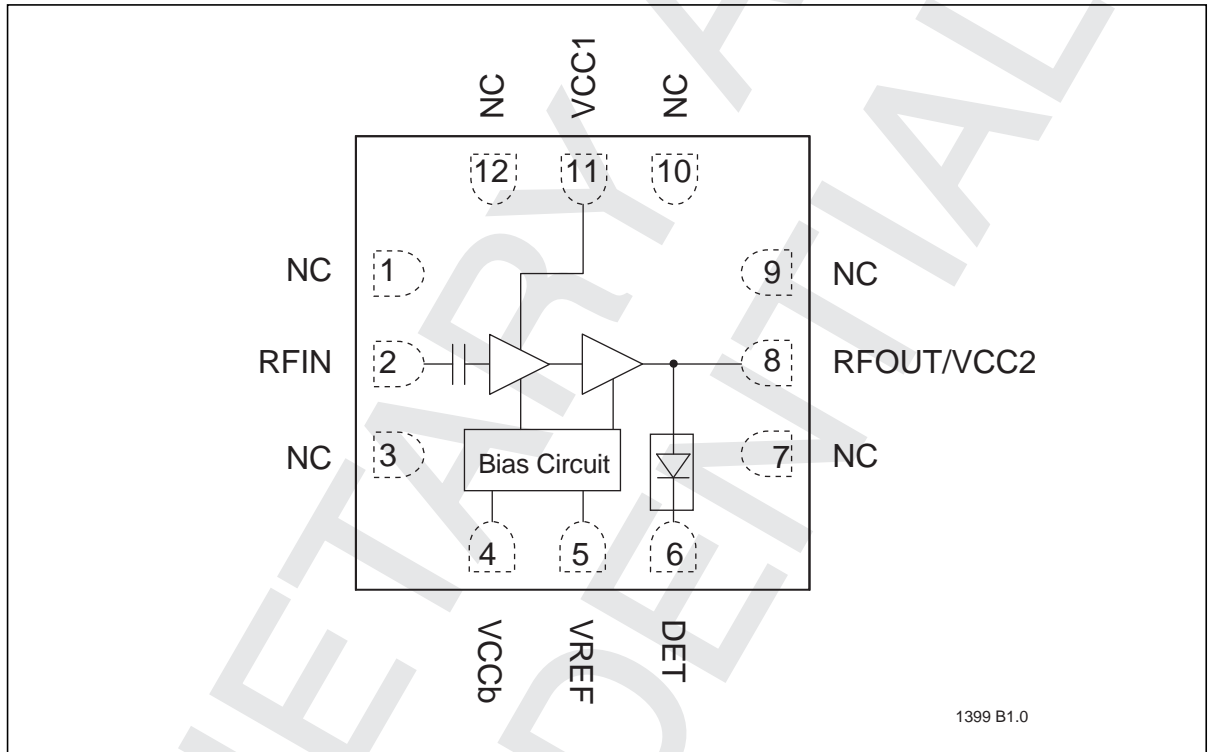

Figure 1: Functional Block Diagram 12-Contact XQFN (QXB)

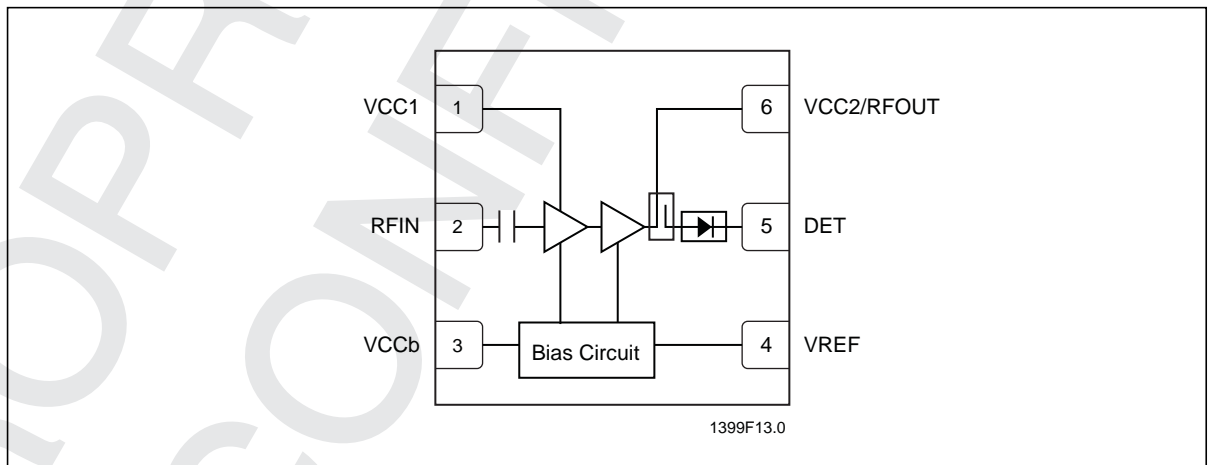

Figure 2: Functional Block Diagram 6-Contact XSON (QX6)



Pin Assignments

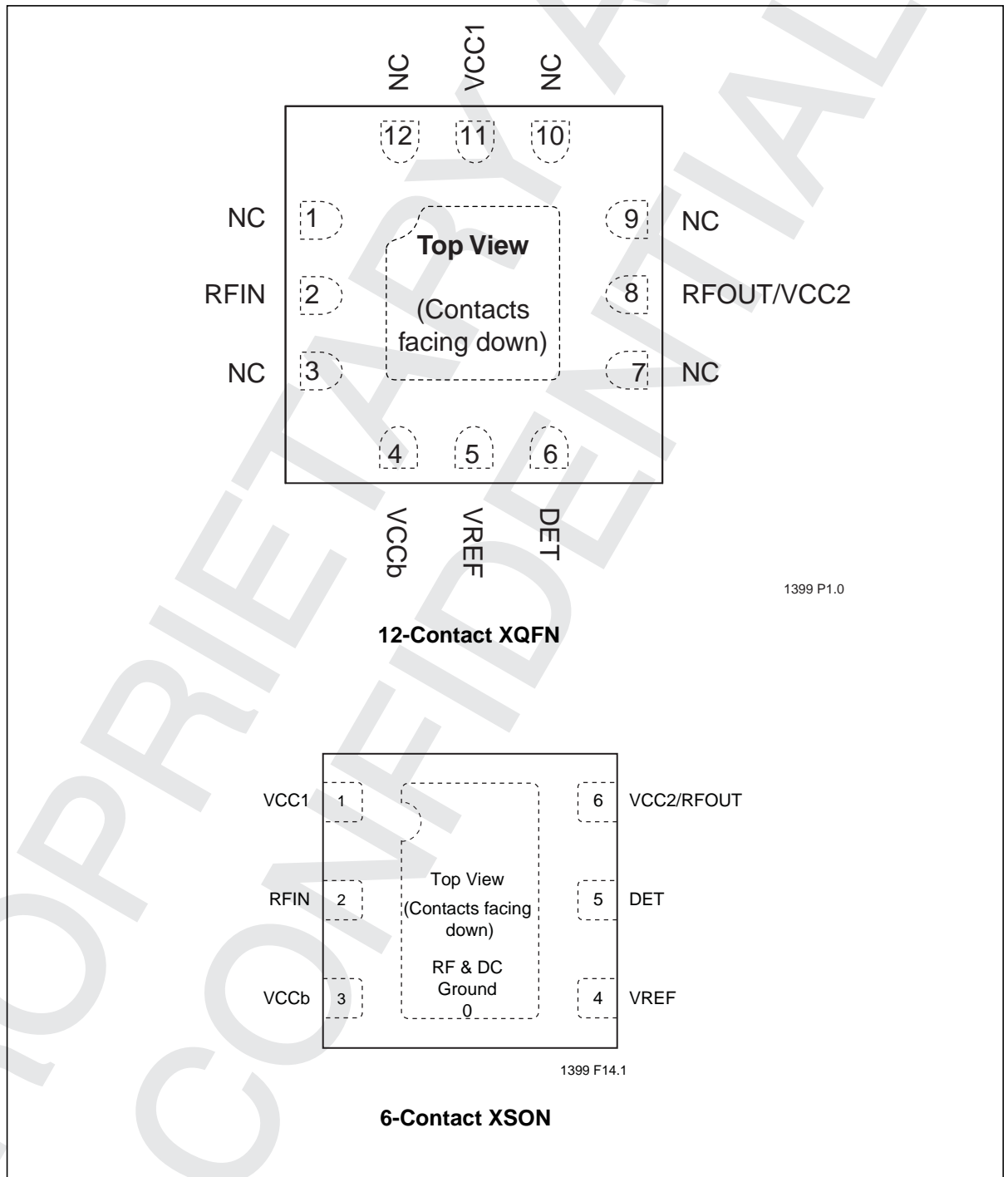

Figure 3: Pin Assignments



Pin Descriptions

Table 1: Pin Description for 12-Contact XQFN (QXB)

Symbol	Pin No.	Pin Name	Type ¹	Function
GND	0	Ground		Low-inductance GND pad
NC	1	No Connection		Unconnected pin
RFIN	2		I	RF input, DC decoupled
NC	3	No Connection		Unconnected pin
VCCb	4	Power Supply	PWR	Supply voltage for bias circuit
VREF	5		PWR	1 st and 2 nd stage idle current control
DET	6		O	On-chip power detector
NC	7	No Connection		Unconnected pin
VCC2/ RFOUT	8	Power Supply	PWR/O	Power Supply, 2 nd stage / RF output
NC	9	No Connection		Unconnected pin
NC	10	No Connection		Unconnected pin
VCC1	11	Power Supply	PWR	Power supply, 1 st stage
NC	12	No Connection		Unconnected pin

T1.0 75073

1. I=Input, O=Output

Table 2: Pin Description, 6-contact XSON (QX6)

Symbol	Pin No.	Pin Name	Type ¹	Function
GND	0	Ground		Low inductance GND pad
VCC1	1	Power Supply	PWR	Power supply, 1 st stage
RFIN	2		I	RF input, DC decoupled
VCCb	3	Power Supply	PWR	Supply voltage for bias circuit
VREF	4		PWR	1 st and 2 nd stage idle current control
Det	5		O	On-chip power detector
VCC2/ RFOUT	6	Power Supply	PWR/O	Power supply, 2 nd stage/ RF Output

T2.0 75073

1. I=Input, O=Output



Electrical Specifications

The AC and DC specifications for the power amplifier interface signals. Refer to Table 4 for the DC voltage and current specifications. Refer to Figures 4 through 11 for the RF performance.

Absolute Maximum Stress Ratings (Applied conditions greater than those listed under “Absolute Maximum Stress Ratings” may cause permanent damage to the device. This is a stress rating only and functional operation of the device at these conditions or conditions greater than those defined in the operational sections of this data sheet is not implied. Exposure to absolute maximum stress rating conditions may affect device reliability.)

Input power to pin 2 (P_{IN})	+5 dBm
Average output power (P_{OUT}) ¹	+26 dBm
Supply Voltage at pins 4, 8, and 11 (V_{CC}) for 12-contact XQFN	-0.3V to +5.0V
Supply Voltage at pins 1, 3, and 6 (V_{CC}) for 6-contact XSON	-0.3V to +5.0V
Reference voltage to pin 5 (V_{REF}) or 12-contact XQFN	-0.3V to +3.3V
Reference voltage to pin 4 (V_{REF}) for 6-contact XSON	-0.3V to +3.3V
DC supply current (I_{CC}) ²	400 mA
Operating Temperature (T_A)	-40°C to +85°C
Storage Temperature (T_{STG})	-40°C to +120°C
Maximum Junction Temperature (T_J)	+150°C
Surface Mount Solder Reflow Temperature	260°C for 10 seconds

1. Never measure with CW source. Pulsed single-tone source with <50% duty cycle is recommended. Exceeding the maximum rating of average output power could cause permanent damage to the device.
2. Measured with 100% duty cycle 54 Mbps 802.11g OFDM Signal

Table 3: Operating Range

Range	Ambient Temp	V_{CC}
Industrial	-40°C to +85°C	3.3V

T3.0 75073



2.4 GHz High-Power, High-Gain Power Amplifier

SST12LP08

Table 4: DC Electrical Characteristics at 25°C

Symbol	Parameter	Min.	Typ	Max.	Unit	Test Conditions
V _{CC}	Supply Voltage at pins 4, 8, 11 for 12-contact XQFN	2.75	3.3	4.2	V	Figure 12
	Supply Voltage at pins 1, 3, 6 for 6-contact XSON	2.75	3.3	4.2	V	Figures 13 and 14
I _{CC}	Idle current for 802.11g to meet EVM ~3% @ 20 dBm for 12-contact XQFN		85		mA	Figure 12
	Idle current for 802.11g to meet EVM ~3% @ 20 dBm for 6-contact XSON		65		mA	Figure 13
	Idle current for 802.11g to meet EVM ~3% @ 18 dBm for 6-contact XSON		48		mA	Figure 14
I _{CC} (802.11g)	Current consumption for 802.11g to meet EVM ~3% @ 20 dBm for 12-contact XQFN		148		mA	Figure 12
	Current consumption for 802.11g to meet EVM ~3% @ 20 dBm for 6-contact XSON		140		mA	Figure 13
	Current Consumption for 802.11g to meet EVM ~3% @ 18 dBm for 6-contact XSON		95		mA	Figure 14
I _{CC} (802.11b/g)	Current consumption for 802.11b/g, 23.5 dBm for 12-contact XQFN		200		mA	Figure 12
	Current consumption for 802.11b/g, 23.5 dBm for 6-contact XSON		200		mA	Figure 13
	Current Consumption for 802.11b/g, 22 dBm for 6-contact XSON		140		mA	Figure 14
V _{REG}	Reference Voltage for 12-contact XQFN with 75Ω resistor	2.75	2.85	2.95	V	Figure 12
	Reference Voltage for 6-contact XSON with 180Ω resistor	2.75	2.85	2.95	V	Figure 13
	Reference Voltage for 6-contact XSON with 390Ω resistor	2.75	2.85	2.95	V	Figure 14

T4.2 75073

Table 5: AC Electrical Characteristics for Configuration at 25°C

Symbol	Parameter	Min.	Typ	Max.	Unit
F _{L-U}	Frequency range	2412		2484	MHz
G	Small signal gain	29	30		dB
G _{VAR1}	Gain variation over band (2412–2484 MHz)			±0.5	dB
G _{VAR2}	Gain ripple over channel (20 MHz)		0.2		dB
ACPR	Meet 11b spectrum mask	23			dBm
	Meet 11g OFDM 54 Mbps spectrum mask	23			dBm
Added EVM	@ 20 dBm output with 11g OFDM 54 Mbps signal		3		%
2f, 3f, 4f, 5f	Harmonics at 22 dBm, without external filters			-40	dBc

T5.2 75073



Typical Performance Characteristics

Test Conditions: $V_{CC} = 3.3V$, $T_A = 25^\circ C$, unless otherwise noted

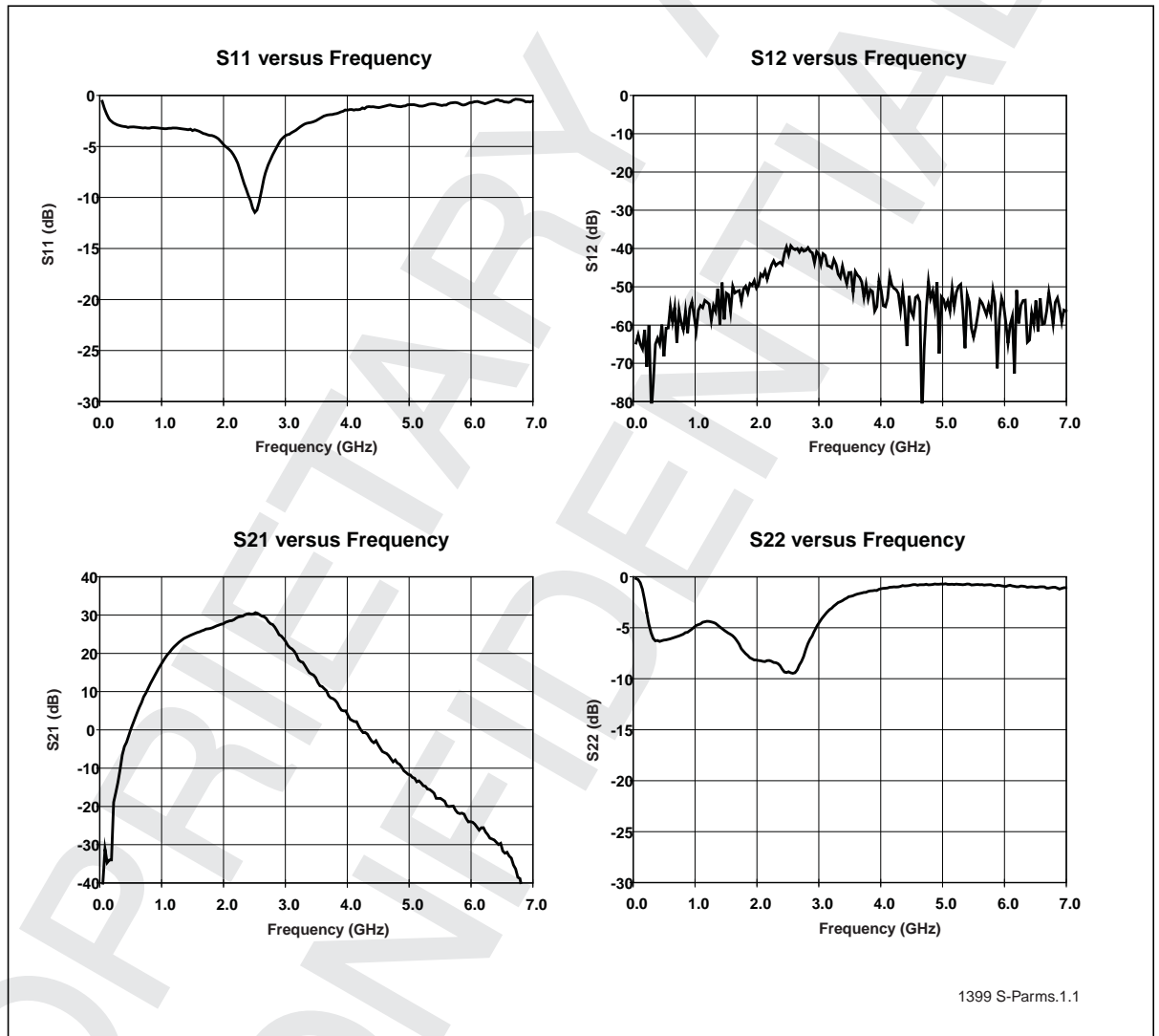

Figure 4: S-Parameters



Typical Performance Characteristics

Test Conditions: $V_{CC} = 3.3V$, $T_A = 25^\circ C$, 54 Mbps 802.11g OFDM Signal, equalizer training using sequence plus data

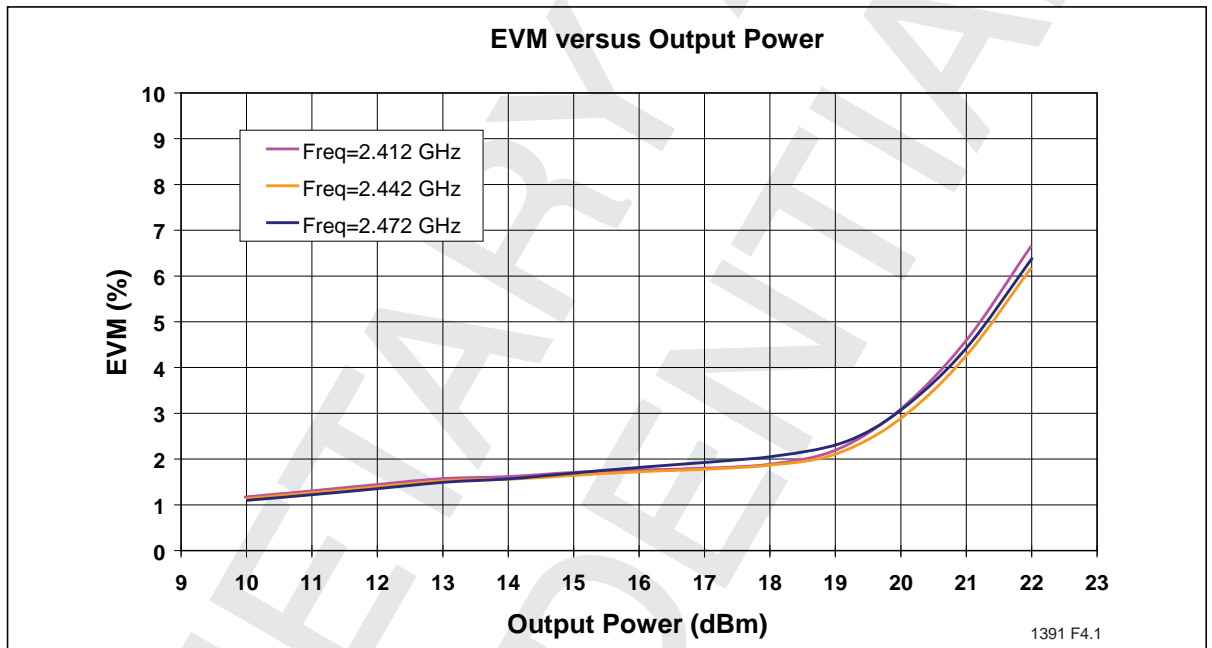

Figure 5: EVM versus Output Power measured with “sequence plus data” channel estimation

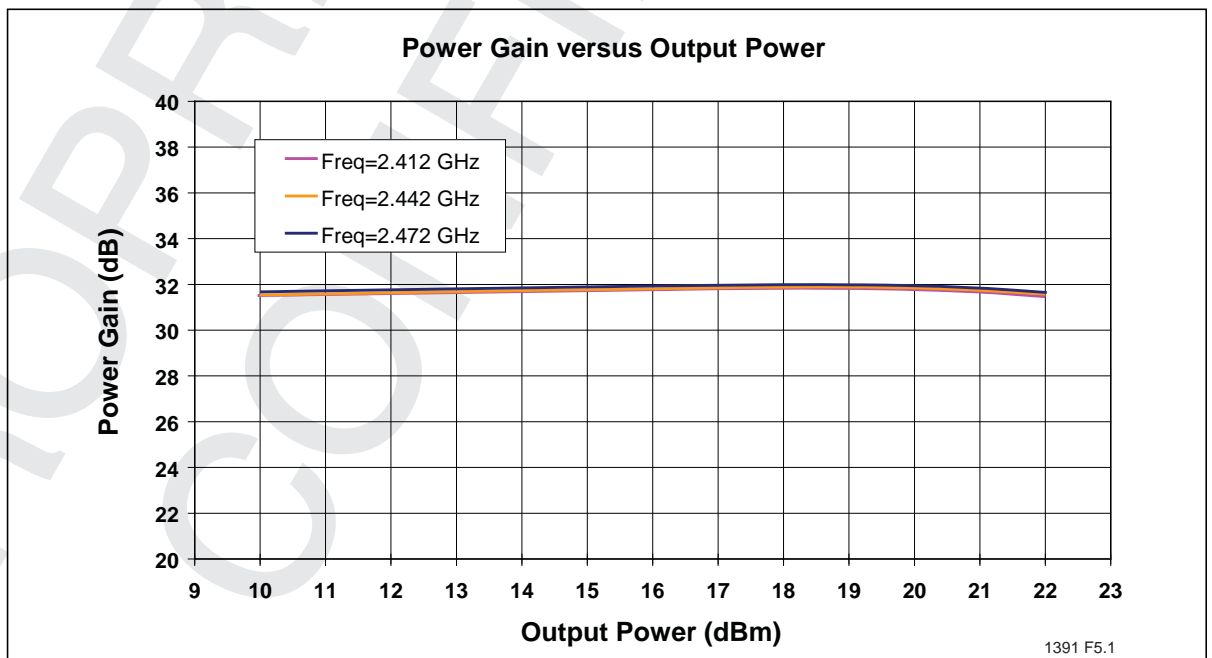

Figure 6: Power Gain versus Output Power



2.4 GHz High-Power, High-Gain Power Amplifier

SST12LP08

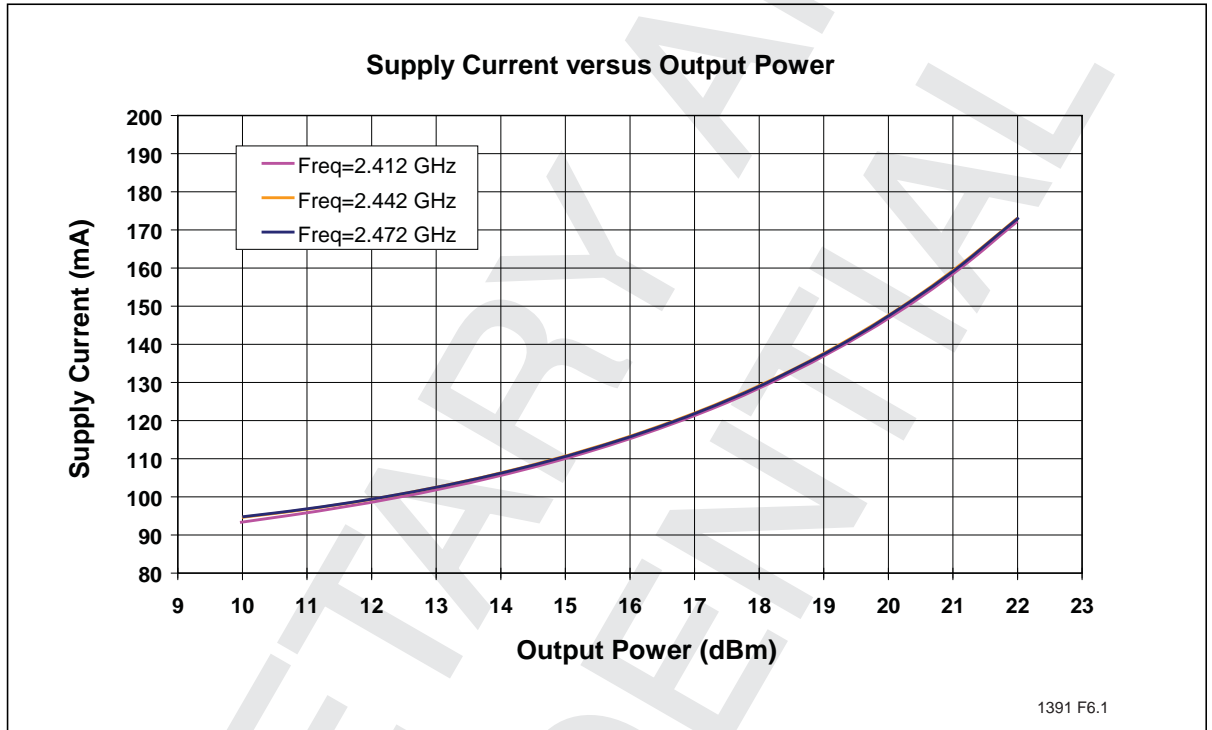

Figure 7: Total Current Consumption for 802.11g operation versus Output Power

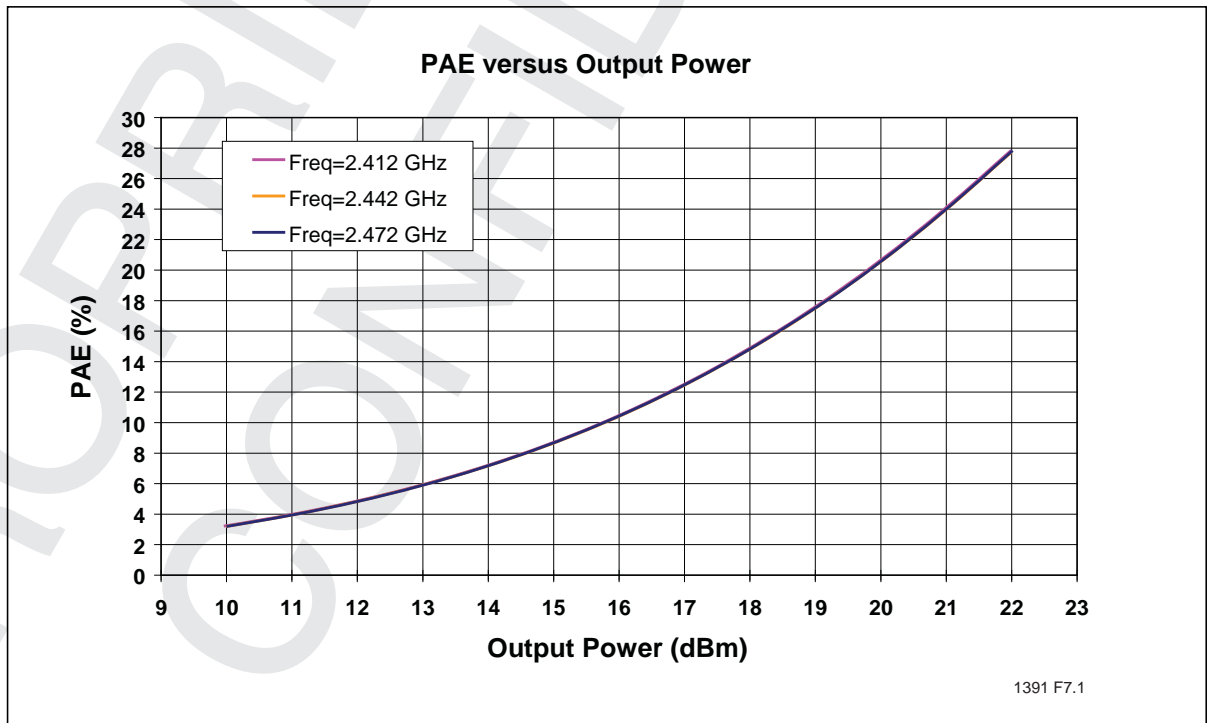

Figure 8: PAE versus Output Power



2.4 GHz High-Power, High-Gain Power Amplifier

SST12LP08

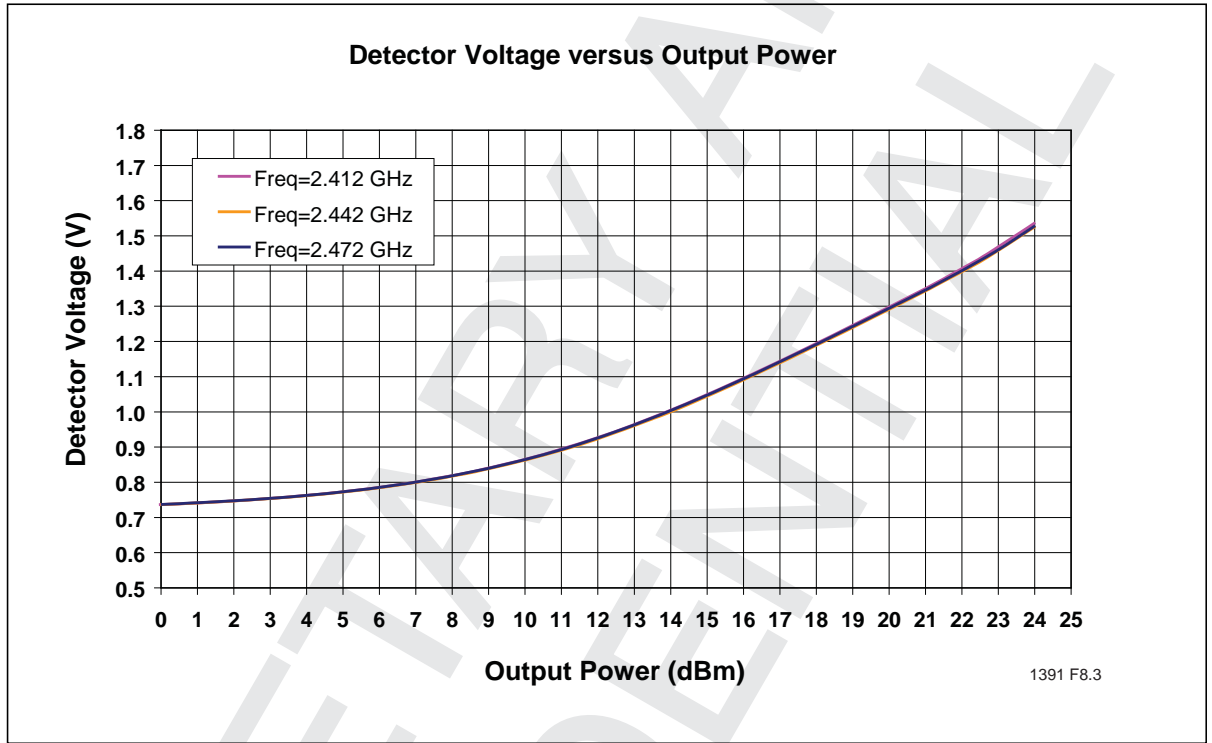

Figure 9: Detector Characteristics versus Output Power

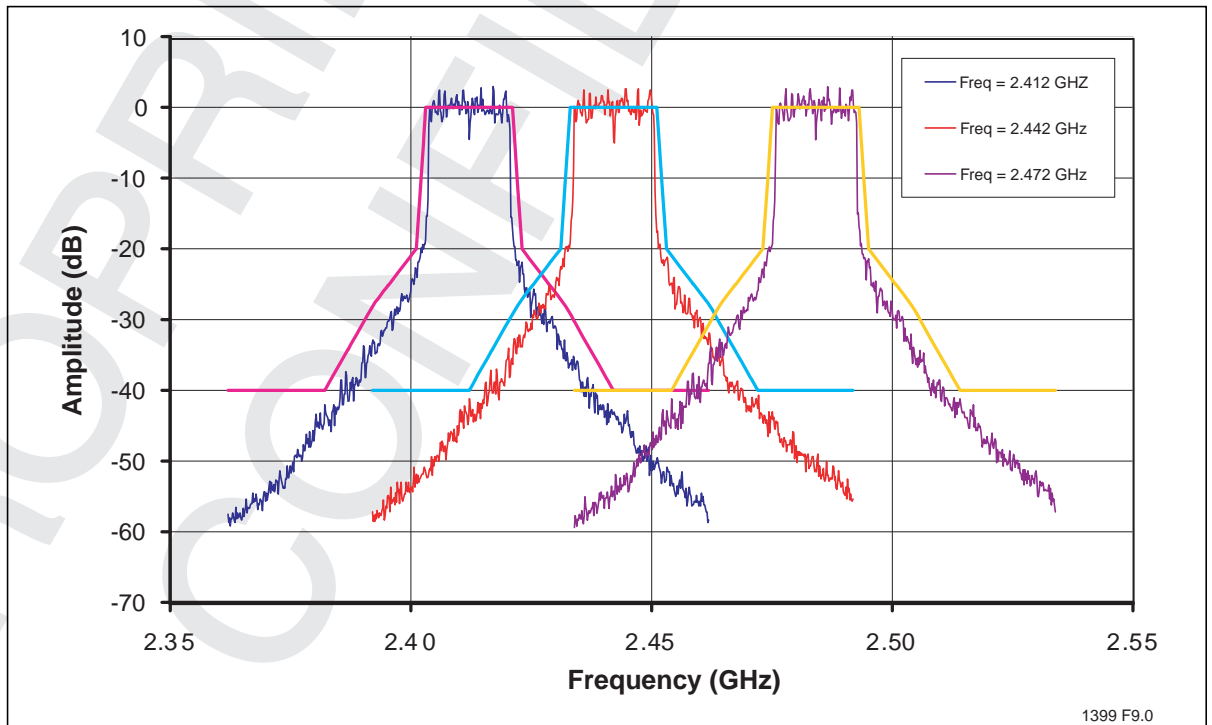

Figure 10: 802.11g Spectrum Mask at 23.5 dBm, Total Current 200 mA



Typical Performance Characteristics

Test Conditions: $V_{CC} = 3.3V$, $T_A = 25^\circ C$, 1 Mbps 802.11b CCK Signal

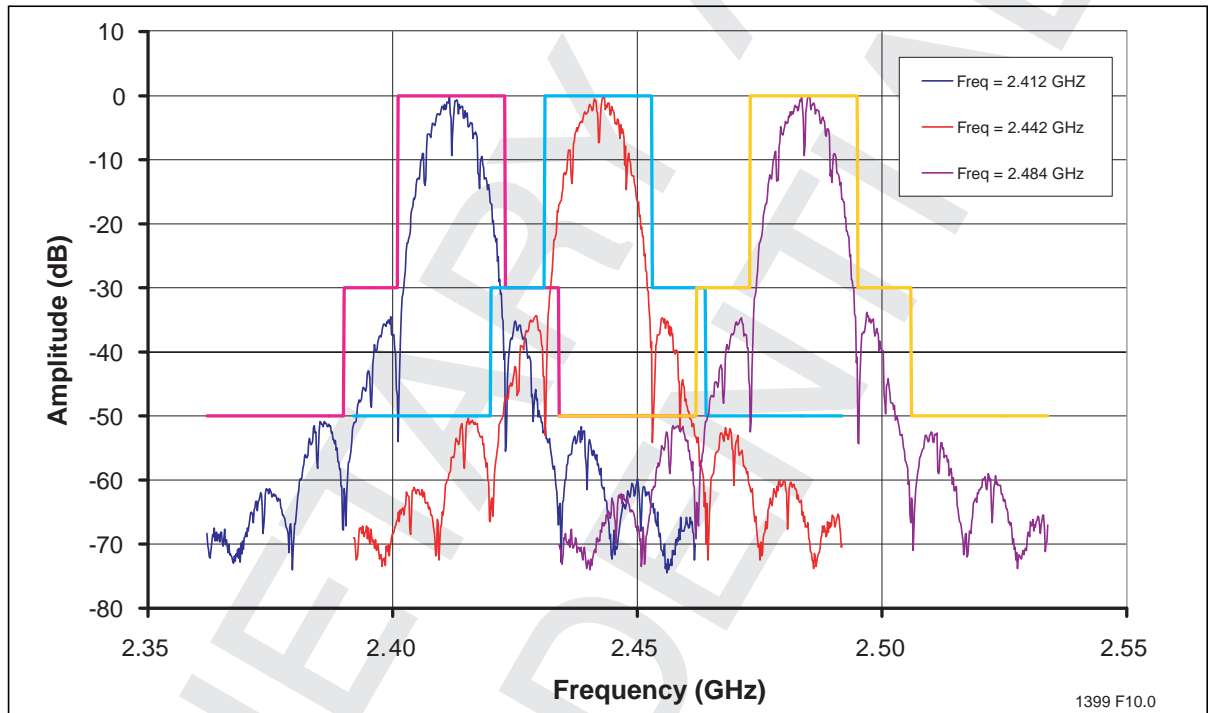

Figure 11:802.11b Spectrum Mask at 23.5 dBm, Total Current 200mA



2.4 GHz High-Power, High-Gain Power Amplifier SST12LP08

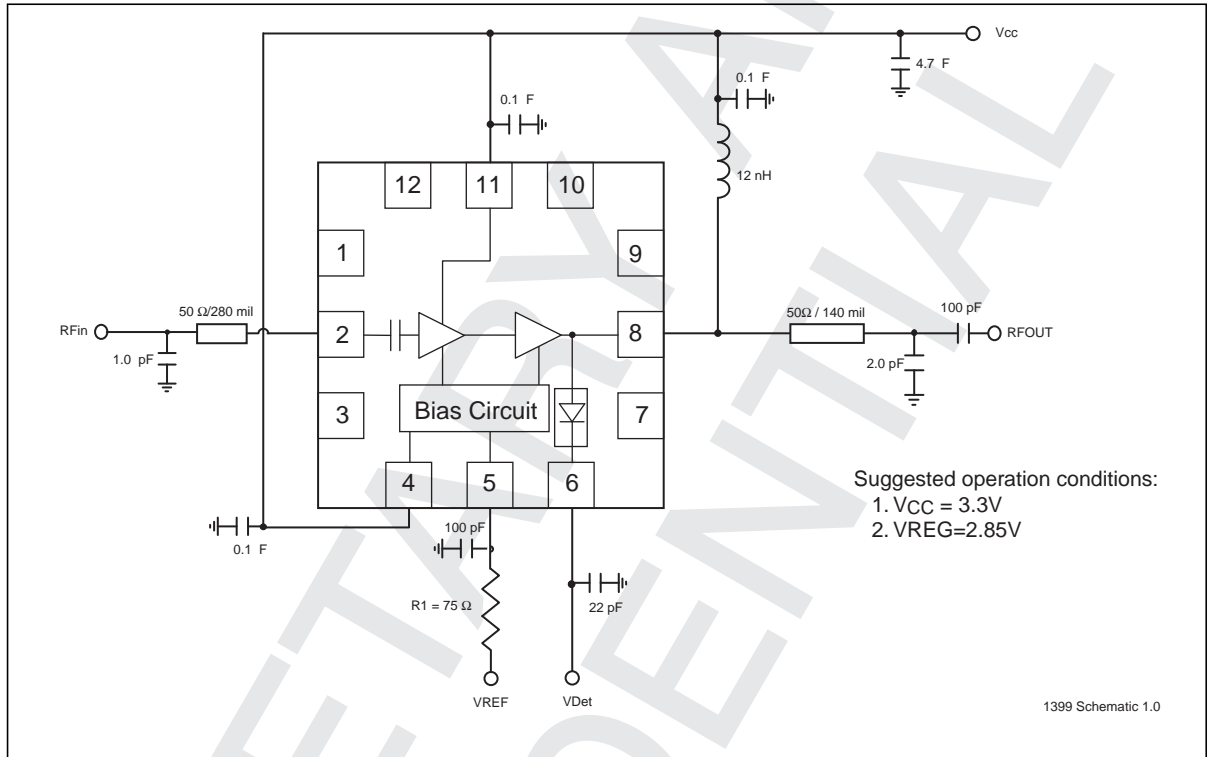

Figure 12: Typical Schematic for 12-Contact XQFN (QXB) for High-Power Applications

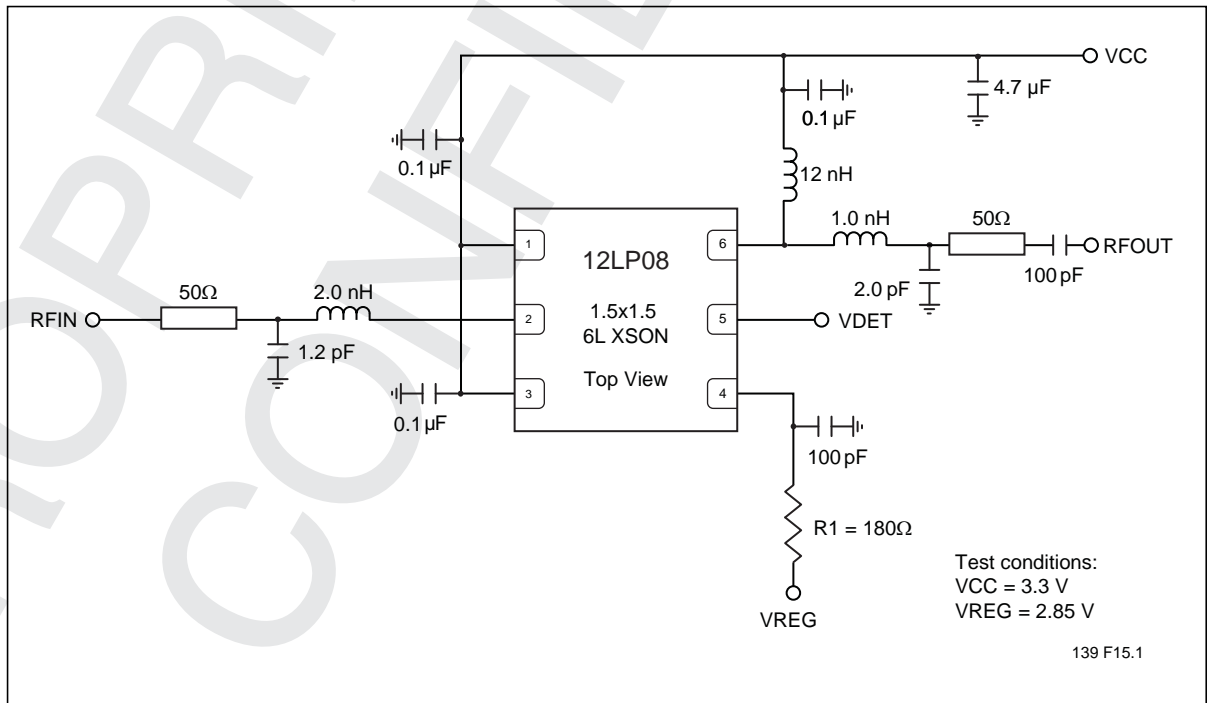

Figure 13: Typical Schematic for 6-Contact XSON (QX6) for High-Power Applications



2.4 GHz High-Power, High-Gain Power Amplifier

SST12LP08

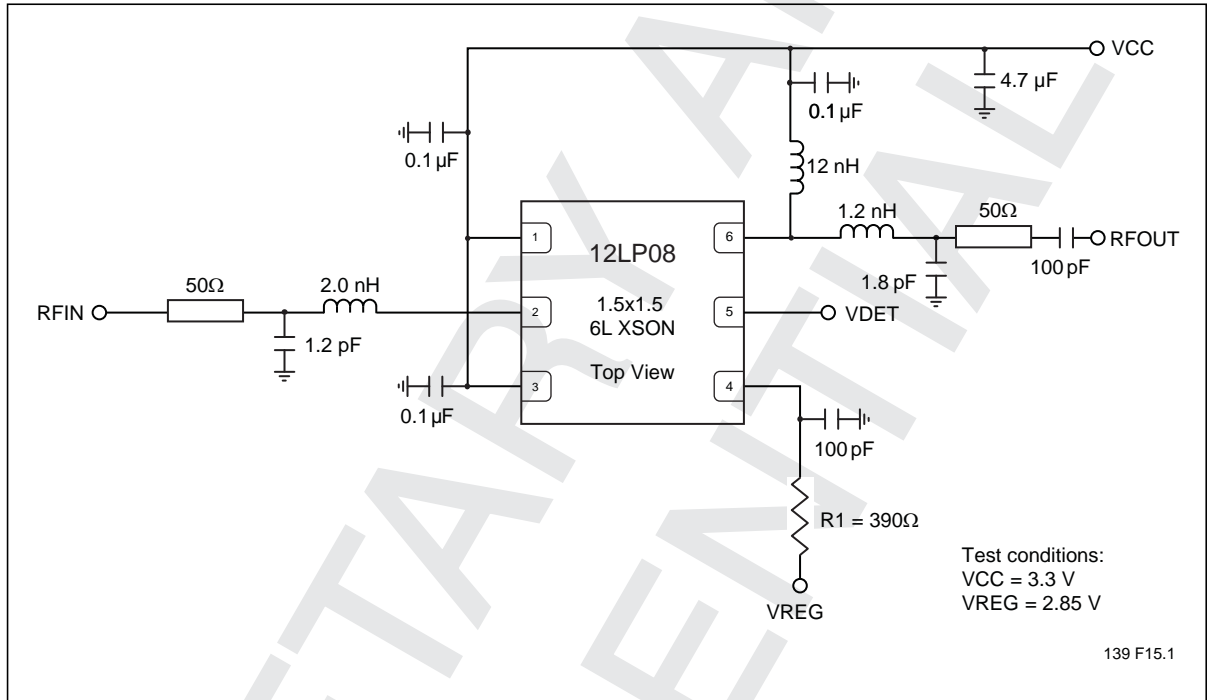
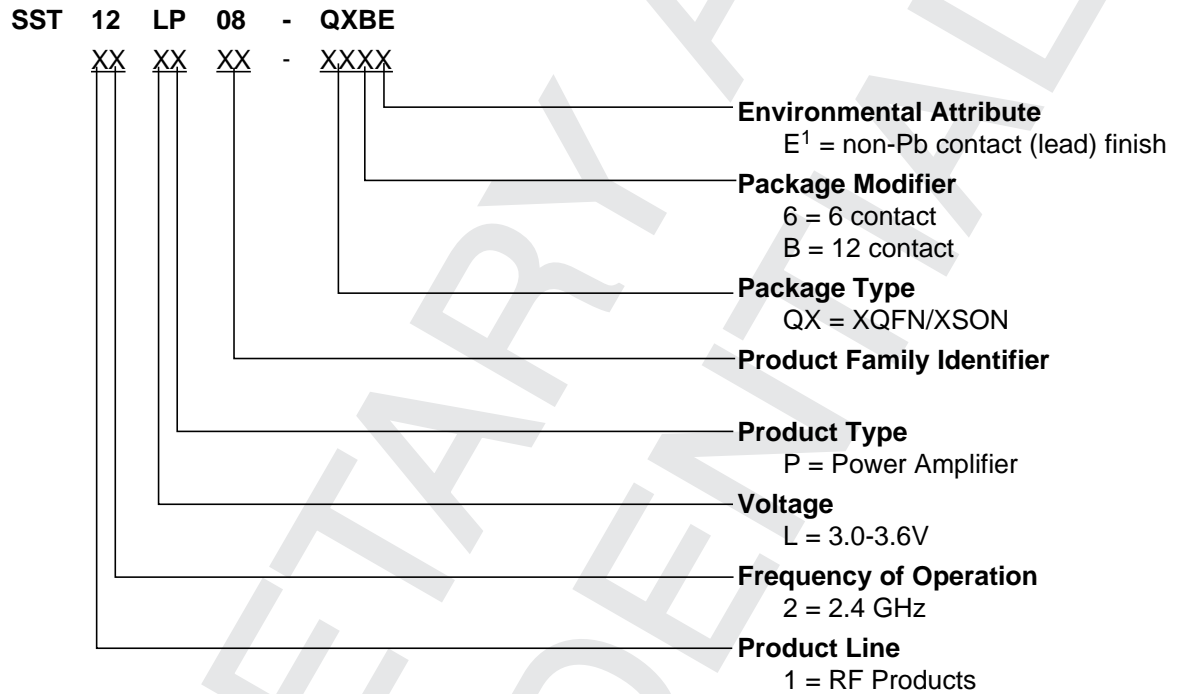

Figure 14: Typical Schematic for 6-Contact XSON (QX6) for High-Efficiency Applications



Product Ordering Information



1. Environmental suffix "E" denotes non-Pb solder. SST non-Pb solder devices are "RoHS Compliant".

Valid combinations for SST12LP08

SST12LP08-QXBE SST12LP08-QX6E

SST12LP08 Evaluation Kits

SST12LP08-QXBE-K SST12LP08-QX6E-K

Note: Valid combinations are those products in mass production or will be in mass production. Consult your SST sales representative to confirm availability of valid combinations and to determine availability of new combinations.



Packaging Diagrams

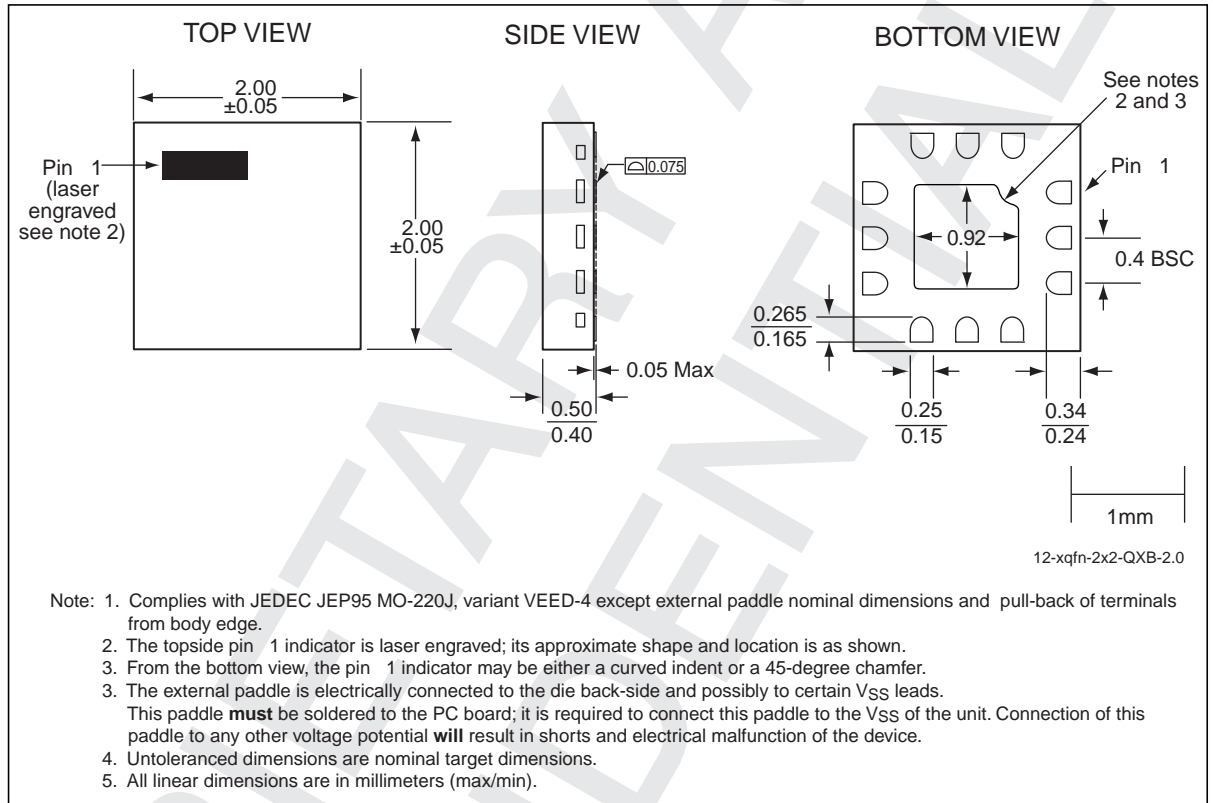

Figure 15: 12-Contact Extremely-thin Quad Flat No-lead (XQFN)
SST Package Code: QXB



2.4 GHz High-Power, High-Gain Power Amplifier

SST12LP08

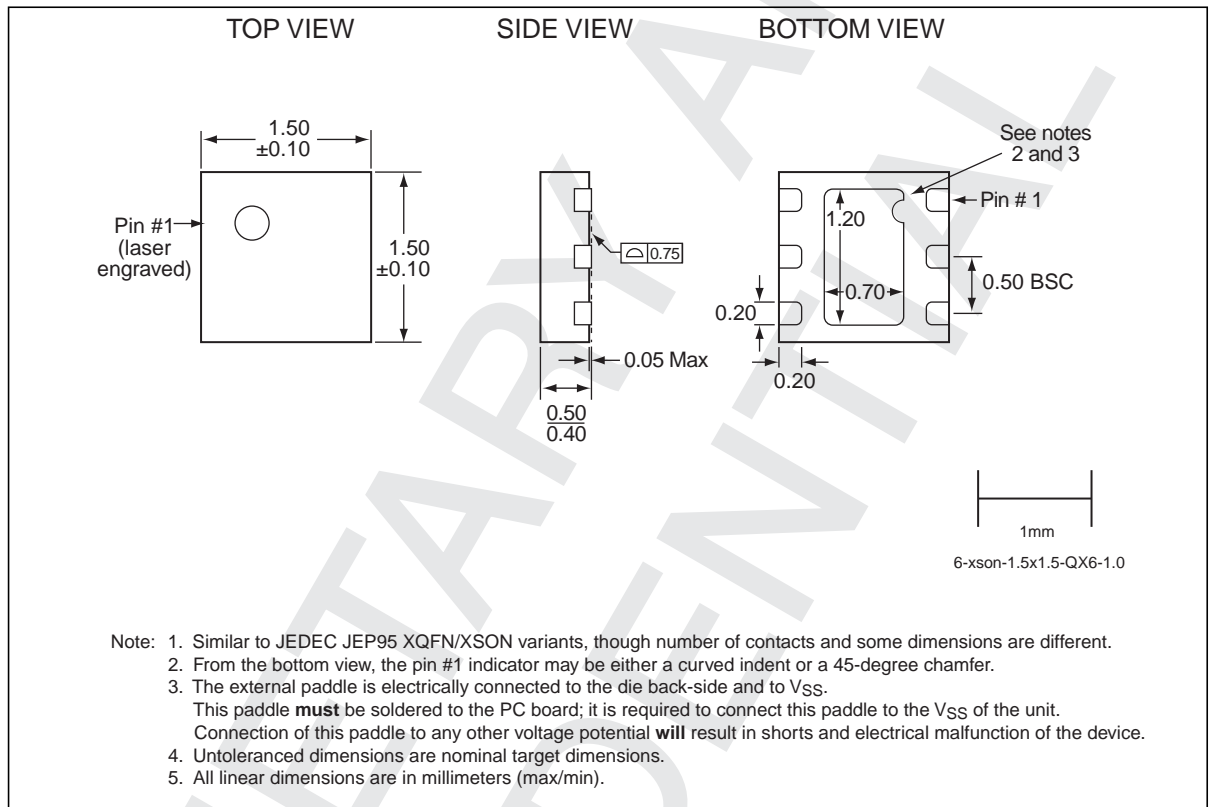

Figure 16: 6-Contact Extremely-thin Quad Small Outline No-lead (XSON)
SST Package Code: QX6

**Table 6:** Revision History

Revision	Description	Date
00	<ul style="list-style-type: none"> Initial release of data sheet 	Apr 2009
01	<ul style="list-style-type: none"> Revised Figure 9 on page 11 	May 2009
02	<ul style="list-style-type: none"> Added information for Qx6 package. Revised Table 4 	Aug 2009
03	<ul style="list-style-type: none"> Updated "Electrical Specifications" and Table 4 	Nov 2009
04	<ul style="list-style-type: none"> Changed document status to "Data Sheet." 	Feb 2010
A	<ul style="list-style-type: none"> Applied new document format Released document under letter revision system Updated Spec number from S71399 to DS75073 	Mar 2012
B	<ul style="list-style-type: none"> Updated Figure 15 on page 16 to reflect new Pin1 indicator Updated "Test Conditions" statement on page 9 	Jun 2012

ISBN:978-1-62076-384-1

© 2012 Silicon Storage Technology, Inc—a Microchip Technology Company. All rights reserved.

SST, Silicon Storage Technology, the SST logo, SuperFlash, MTP, and FlashFlex are registered trademarks of Silicon Storage Technology, Inc. MPF, SQI, Serial Quad I/O, and Z-Scale are trademarks of Silicon Storage Technology, Inc. All other trademarks and registered trademarks mentioned herein are the property of their respective owners.

Specifications are subject to change without notice. Refer to www.microchip.com for the most recent documentation. For the most current package drawings, please see the Packaging Specification located at <http://www.microchip.com/packaging>.

Memory sizes denote raw storage capacity; actual usable capacity may be less.

SST makes no warranty for the use of its products other than those expressly contained in the Standard Terms and Conditions of Sale.

For sales office locations and information, please see www.microchip.com.

Silicon Storage Technology, Inc.
A Microchip Technology Company
www.microchip.com

Компания «Океан Электроники» предлагает заключение долгосрочных отношений при поставках импортных электронных компонентов на взаимовыгодных условиях!

Наши преимущества:

- Поставка оригинальных импортных электронных компонентов напрямую с производств Америки, Европы и Азии, а так же с крупнейших складов мира;
- Широкая линейка поставок активных и пассивных импортных электронных компонентов (более 30 млн. наименований);
- Поставка сложных, дефицитных, либо снятых с производства позиций;
- Оперативные сроки поставки под заказ (от 5 рабочих дней);
- Экспресс доставка в любую точку России;
- Помощь Конструкторского Отдела и консультации квалифицированных инженеров;
- Техническая поддержка проекта, помощь в подборе аналогов, поставка прототипов;
- Поставка электронных компонентов под контролем ВП;
- Система менеджмента качества сертифицирована по Международному стандарту ISO 9001;
- При необходимости вся продукция военного и аэрокосмического назначения проходит испытания и сертификацию в лаборатории (по согласованию с заказчиком);
- Поставка специализированных компонентов военного и аэрокосмического уровня качества (Xilinx, Altera, Analog Devices, Intersil, Interpoint, Microsemi, Actel, Aeroflex, Peregrine, VPT, Syfer, Eurofarad, Texas Instruments, MS Kennedy, Miteq, Cobham, E2V, MA-COM, Hittite, Mini-Circuits, General Dynamics и др.);

Компания «Океан Электроники» является официальным дистрибьютором и эксклюзивным представителем в России одного из крупнейших производителей разъемов военного и аэрокосмического назначения «**JONHON**», а так же официальным дистрибьютором и эксклюзивным представителем в России производителя высокотехнологичных и надежных решений для передачи СВЧ сигналов «**FORSTAR**».



JONHON

«**JONHON**» (основан в 1970 г.)

Разъемы специального, военного и аэрокосмического назначения:

(Применяются в военной, авиационной, аэрокосмической, морской, железнодорожной, горно- и нефтедобывающей отраслях промышленности)

«**FORSTAR**» (основан в 1998 г.)

ВЧ соединители, коаксиальные кабели,
кабельные сборки и микроволновые компоненты:

(Применяются в телекоммуникациях гражданского и специального назначения, в средствах связи, РЛС, а так же военной, авиационной и аэрокосмической отраслях промышленности).



Телефон: 8 (812) 309-75-97 (многоканальный)

Факс: 8 (812) 320-03-32

Электронная почта: ocean@oceanchips.ru

Web: <http://oceanchips.ru/>

Адрес: 198099, г. Санкт-Петербург, ул. Калинина, д. 2, корп. 4, лит. А