

BGA HEAT SINK GUIDE - POWER LESS THAN 5 WATTS

Aavid's family of BGA heat sinks offers a wide range of cooling solutions for motherboard, video card, and networking applications. Aavid's Push-Pin™ attachment, available on many of the heat sinks, uses a standard 3.12 mm diameter hole pattern, allowing accommodation of future cooling requirements without board redesign. Plastic pins provide low-cost attachment, while brass pins provide higher reliability in extreme conditions.

ORDERING INFORMATION

Use the 6 digit part number in the upper left hand corner for ordering.

Thermal resistance is calculated at .25 m/s of airflow and does not include the interface. Due to various heat dissipation paths within a BGA device, please test our heat sink in your application.

For different interface material, fan options, color, or clipping variations, please contact your local application engineer.

PART NUMBER 028095 (373224M00000)

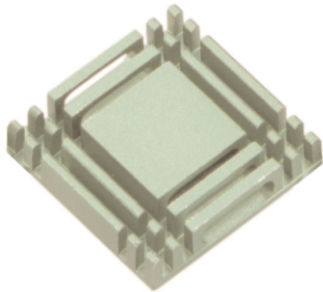

- 28 mm x 28 mm x 6 mm
- Use with epoxy attachment
- 15.2°C/W performance
- Green anodized finish

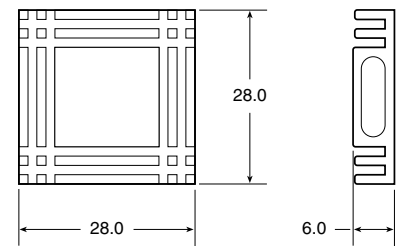

PART NUMBER 031612 (IBAA-2)

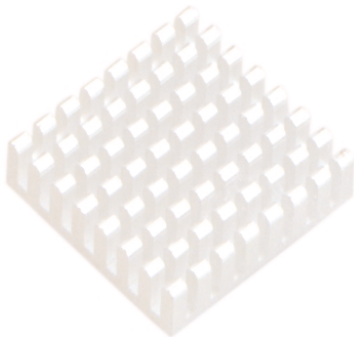

- 28 mm x 28 mm x 8 mm
- Use with epoxy attachment
- 13.5°C/W performance
- Wash finish

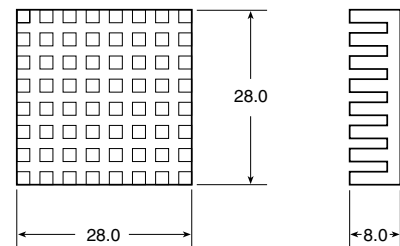

PART NUMBER 030948 (10-6326-27) PLASTIC PUSH-PINS 030949 (10-6326-28) BRASS PUSH-PINS

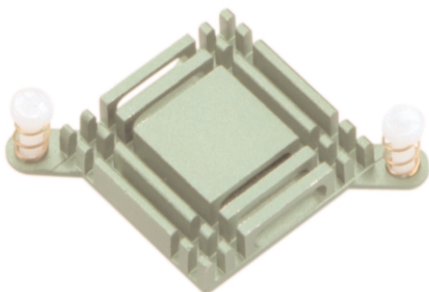

- 28 mm x 28 mm x 6 mm
- Push-Pin attachment
- 15.0°C/W performance
- Pre-applied phase-change interface material
- Black anodized finish

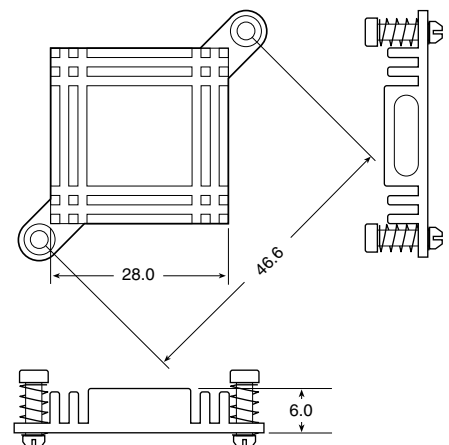

BGA HEAT SINK GUIDE - POWER LESS THAN 8 WATTS

PART NUMBER 031609 (10-6327-01) PLASTIC PUSH-PINS

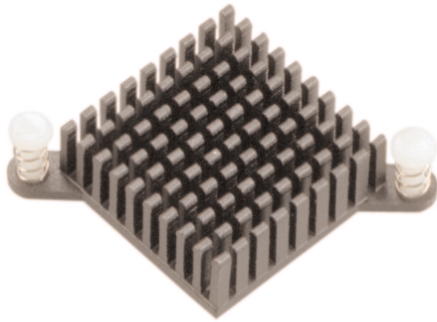

- 28 mm x 28 mm x 10 mm
- Push-Pin attachment
- 12.4°C/W performance
- Black anodized finish

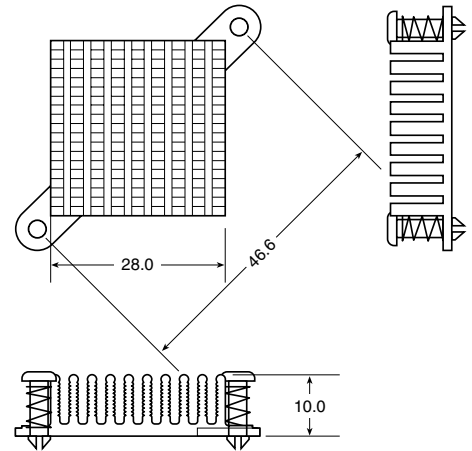

PART NUMBER 031611 (10-5571-02) DOUBLE-SIDED TAPE 028096 (373324M0000) NO INTERFACE FOR EPOXY ATTACHMENT

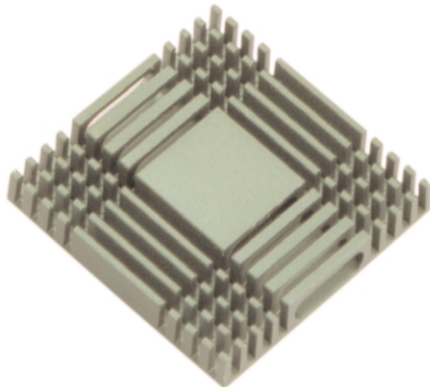

- 37.4 mm x 37.4mm x 6 mm
- 11.2°C/W performance
- Green anodized finish

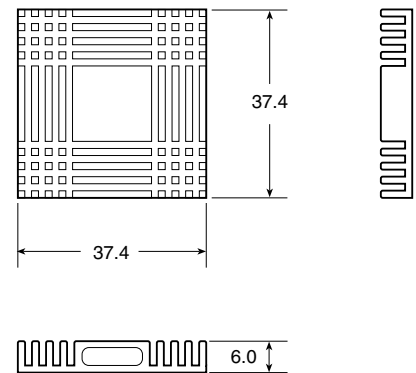

PART NUMBER 031610 (10-5610-02)

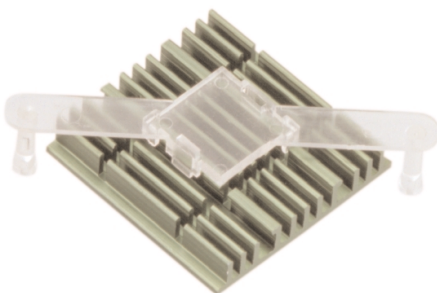

- 37.4mm x 37.4mm x 8.5 mm
- Unique clip attachment
- 11.2 °C/W performance
- Green anodized finish

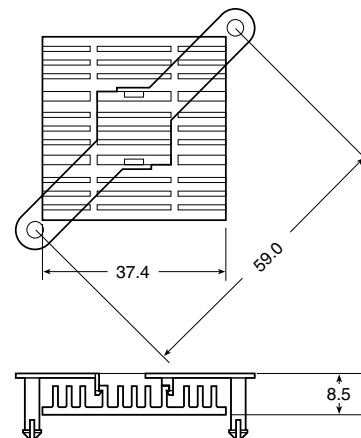

BGA HEAT SINK GUIDE - POWER LESS THAN 10 WATTS

PART NUMBER 031613 (10-5597-02) PLASTIC PUSH-PIN, NO INTERFACE MATERIAL APPLIED
031614 (10-5597-22) PLASTIC PUSH-PIN, PHASE-CHANGE INTERFACE APPLIED
031615 (10-5597-33) BRASS PUSH-PIN, PHASE-CHANGE INTERFACE APPLIED

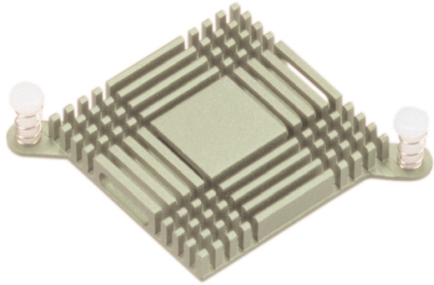

- 37.4 mm x 37.4 mm x 6 mm
- Push-Pin attachment
- 11.0°C/W performance
- 031613 has green anodized finish
- 031614 and 031615 have gold anodized finishes

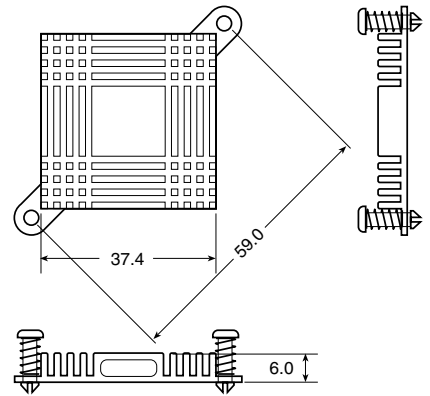

PART NUMBER 030818 (10-5607-04) PLASTIC PUSH-PIN
030819 (10-5607-05) BRASS PUSH-PIN

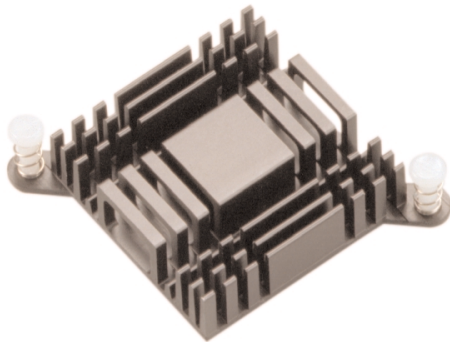

- 37.4 mm x 37.4 mm x 10 mm
- 9.7°C/W performance
- Black anodized finish
- Phase-change interface material: 28 mm x 28 mm

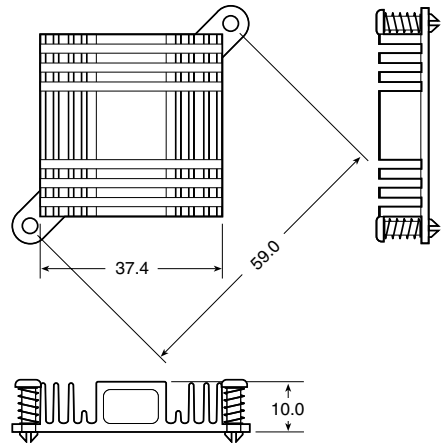

PART NUMBER 031746 SINGLE-BALL FAN, DOUBLE-SIDED TAPE



- 40 mm x 40 mm x 11.5 mm
- 5-Volt, 40 mm x 40 mm x 7 mm DC fan
- 3-Pin connector: 1-red(+), 2-black(-), 3-sensor
- Sensor provides two pulses per revolution
- 3.8°C/W performance
- Black anodized finish

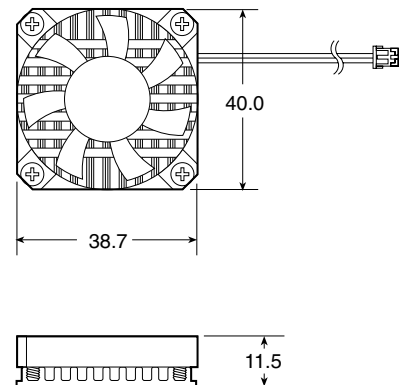

Note: All Aavid fans can be customized to your application. Customizable features include: fan wiring, fan speed, sensor options, bearing style, voltage, connector type, etc. Contact your local application engineer for information.

BGA HEAT SINK GUIDE - POWER LESS THAN 15 WATTS

PART NUMBER 031608 (11-5602-48) SINGLE-BALL FAN 031607 (11-5602-47) DUAL-BALL FAN



- 40 mm x 40 mm x 15 mm
- 5-Volt, 40 mm x 40 mm x 10 mm DC fan
- 3-pin Molex connector:
1-red(+), 2-black(-), 3-sensor
- 1-black(-), 2-red(+), 3-sensor
- 3.5°C/W performance
- Black anodized finish

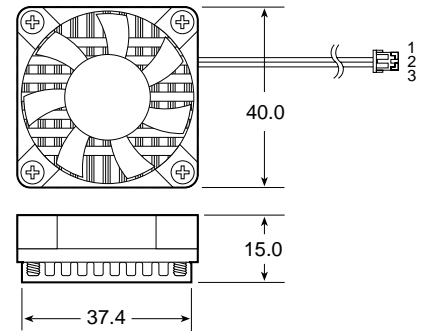

PART NUMBER 031606 (11-5602-46) SINGLE-BALL FAN 031605 (11-5602-45) DUAL-BALL FAN



- Plastic Push-Pin
- 40 mm x 40 mm x 15.0 mm
- 5 Volt 40 mm x 40 mm x 10 mm DC fan
- 3-pin Molex connector:
1-black(-), 2-red(+), 3-sensor
- Sensor is two pulses per revolution
- 3.4°C/W performance
- Black anodized finish

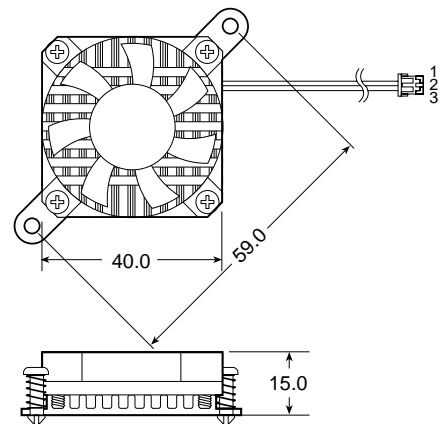

PART NUMBER 031660 (11-5602-50) PLASTIC PUSH-PIN 031661 (11-5602-51) BRASS PUSH-PIN



- One ball bearing
- 40 mm x 40 mm x 11.5 mm
- 12 Volt DC fan
- 2-pin Molex connector:
1-red(+), 2-black(-)
- Phase-change interface material
- 3.7°C/W performance
- Black anodized finish

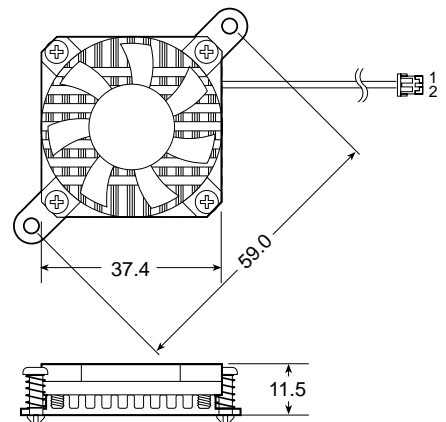

BGA HEAT SINK GUIDE - POWER LESS THAN 15 WATTS

PART NUMBER 031659 (11-5608-13) PLASTIC PUSH-PIN 031658 (11-5608-07) BRASS PUSH-PIN

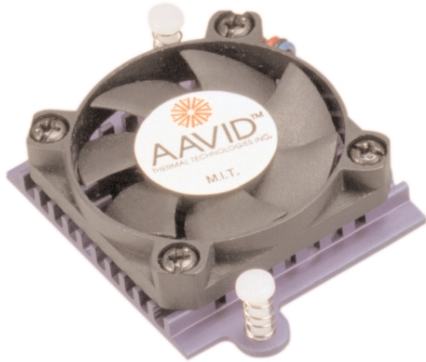

- 40 mm x 40 mm x 11.5 mm
- 12 Volt, 40 mm x 40 mm x 7 mm DC fan
- 3-pin Molex connector:
1-red(+), 2-black(-), 3-sensor
- Sensor provides two pulses per revolution
- 3.5 °C/W performance
- Black anodized finish

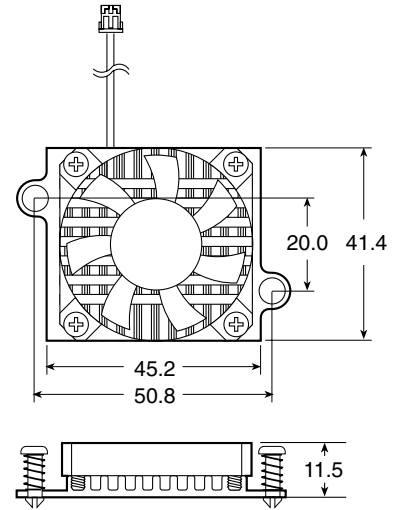

Note: Aavid has several passive heat sinks using this alternate Push-Pin hole pattern. Contact your local application engineer for information.



This data sheet represents only one of a broad range of products we make to cool electronics. Our representatives can help you configure a complete cooling solution for your individual applications. For assistance, contact any one of them from our web site or at the locations below.

Aavid Thermal Products, Inc., along with Fluent Inc.'s Icepak thermal design software and Applied Thermal Technologies, Inc. thermal design and validation services, make up

The Total Integrated Solution for Cooling Electronics™. For more information on how to put our strengths to work for you,

visit our web site at: <http://www.aavid.com>; TEL: (603) 224-9988,

or contact Fluent at: <http://www.icepak.com>; TEL: (603) 643-2600, or Applied at: <http://www.thermalcooling.com>; TEL: (603) 666-4100.

For technical assistance, or placing an order, please visit our web site for the

local sales representative: <http://www.aavid.com/rep/index.html>

or distributor near you: <http://www.aavid.com/distrib/index.html>

Corporate Office - Aavid USA: 143 N. Main Street, Concord, NH 03301 TEL: (603) 224-9988 FAX: (603) 223-1738

International Locations:

Aavid Canada: 440 Hanlon Road • Woodbridge, Ontario • Canada L4L 3P6 • TEL: (905) 850-9595 • FAX: (905) 850-9599

Aavid Singapore: No. 5 Woodlands Industrial Park E1 757728 • TEL: (65)362 8388 • FAX: (65)362 8588

Aavid Taiwan/Japan: 3F, No. 25, Lane 228, AnKang Road, NeiHu, Taipei • 114 Taiwan R.O.C. • TEL: (886) 22-793-5677 • FAX: (886) 22-793-3460

Aavid Europe: Unit C Hillbottom Road • Sands Industrial Estate • High Wycombe, Bucks, England HP12 4HS • TEL: (44) 1494-474747 • FAX: (44) 1494-474748

PLEASE NOTE: Our customers are reminded that they bear the responsibility for testing Aavid Thermal Products' products for proposed use. Any information furnished by Aavid is believed to be accurate and reliable, but our customers must bear all responsibility for use and applications of Aavid products. AAVID MAKES NO WARRANTIES AS TO THE FITNESS, MERCHANTABILITY, OR SUITABILITY OF ANY AAVID PRODUCTS FOR ANY SPECIFIC OR GENERAL USES. AAVID SHALL NOT BE LIABLE FOR INCIDENTAL OR CONSEQUENTIAL DAMAGES OF ANY KIND. All Aavid products are sold pursuant to the Aavid Domestic Terms and Conditions of Sale in effect from time to time, a copy of which shall be furnished upon request (8911A).

Push-Pin is a trademark of Aavid Thermal Products, Inc.

Copyright © Aavid Thermal Products, Inc. October 1999 (Revision 1).

All icons, drawings, illustrations, and trademarks are the property of Aavid Thermal Products, Inc. and may not be reproduced without express written permission.

Mouser Electronics

Authorized Distributor

Click to View Pricing, Inventory, Delivery & Lifecycle Information:

[Aavid:](#)

[11-5608-13](#) [11-5602-51G REV D](#) [031746](#) [11-5602-45](#) [11-5602-46](#)

Компания «Океан Электроники» предлагает заключение долгосрочных отношений при поставках импортных электронных компонентов на взаимовыгодных условиях!

Наши преимущества:

- Поставка оригинальных импортных электронных компонентов напрямую с производств Америки, Европы и Азии, а так же с крупнейших складов мира;
- Широкая линейка поставок активных и пассивных импортных электронных компонентов (более 30 млн. наименований);
- Поставка сложных, дефицитных, либо снятых с производства позиций;
- Оперативные сроки поставки под заказ (от 5 рабочих дней);
- Экспресс доставка в любую точку России;
- Помощь Конструкторского Отдела и консультации квалифицированных инженеров;
- Техническая поддержка проекта, помощь в подборе аналогов, поставка прототипов;
- Поставка электронных компонентов под контролем ВП;
- Система менеджмента качества сертифицирована по Международному стандарту ISO 9001;
- При необходимости вся продукция военного и аэрокосмического назначения проходит испытания и сертификацию в лаборатории (по согласованию с заказчиком);
- Поставка специализированных компонентов военного и аэрокосмического уровня качества (Xilinx, Altera, Analog Devices, Intersil, Interpoint, Microsemi, Actel, Aeroflex, Peregrine, VPT, Syfer, Eurofarad, Texas Instruments, MS Kennedy, Miteq, Cobham, E2V, MA-COM, Hittite, Mini-Circuits, General Dynamics и др.);

Компания «Океан Электроники» является официальным дистрибьютором и эксклюзивным представителем в России одного из крупнейших производителей разъемов военного и аэрокосмического назначения «**JONHON**», а так же официальным дистрибьютором и эксклюзивным представителем в России производителя высокотехнологичных и надежных решений для передачи СВЧ сигналов «**FORSTAR**».



JONHON

«**JONHON**» (основан в 1970 г.)

Разъемы специального, военного и аэрокосмического назначения:

(Применяются в военной, авиационной, аэрокосмической, морской, железнодорожной, горно- и нефтедобывающей отраслях промышленности)

«**FORSTAR**» (основан в 1998 г.)

ВЧ соединители, коаксиальные кабели, кабельные сборки и микроволновые компоненты:

(Применяются в телекоммуникациях гражданского и специального назначения, в средствах связи, РЛС, а так же военной, авиационной и аэрокосмической отраслях промышленности).



Телефон: 8 (812) 309-75-97 (многоканальный)

Факс: 8 (812) 320-03-32

Электронная почта: ocean@oceanchips.ru

Web: <http://oceanchips.ru/>

Адрес: 198099, г. Санкт-Петербург, ул. Калинина, д. 2, корп. 4, лит. А