

LL06ED-AExxL-Mx Data Sheet

For EDIXEON Multi-Color and Single-Color LEDs



Features:

- High efficiency
- Available in 3 beam Patterns
- Optimized for uniform effects
- Lens with Housing

Typical applications :

- Stage Lighting
- Street Lights
- Decorative Light
- Architectural Lighting
- Down Light

Table of Contents

General Information.....	2
General Specifications.....	2
Optical Specifications.....	3
Mechanical Specifications.....	4
Illumination charts.....	5
Package Specifications.....	6
Product Nomenclature.....	7

General Information

- **Compatible Led Type :**

The LL06ED-AExxL-Mx 6 in 1 lenses are optimized for both Multi-Color R.G.B Edison LEDs and Single-Color Edison LEDs (Edixeon 1LA5 White) from Edison Opto. ⁽¹⁾

- **Beam Angle Type :**

An optimized profile integrate different front shape enable the generation of three differer lens models : smallest beam(08deg);medium beam (25deg);biggest beam(40deg). ⁽²⁾

- **The Way to Assembly :**

The Lens should be assembled to the PCB board or MCPCB upon LEDs which provides the most appropriate related position, so as to achieve the best uniform results

*** Manually installation or if necessary thermal glue are recommended.**

- **Function :**

LL06ED-AExxL-Mx provides exceptional color mixing result with the highest efficiency through careful engineering and precision manufacturing process.

General Specifications

- Lens Material Optical Grade PMMA PC
- Operating Temperature range -40°C ~ + 70°C (upper limit +80°C)
- Storage Temperature range -40°C ~ + 70°C (upper limit +80°C)

*Average transmittance in visible spectrum 400nm~700nm > 90%

Notes:

(1) Edixeon 1LA5 is a trademark of Edison,Inc , for technical information on LEDs, please refer to Edison,Inc, <http://www.edison-opto.com.tw/>

(2) Typical beam divergence will be affected by different color of LEDs.

Optical Specifications [Typical beam Angle and intensity (cd/lm) of LL06 lenses]

• Edixeon 1LA5 LED

Typical Cone Angle (degree) ⁽³⁾ with Edixeon 1LA5			
Part Number	Red LEDs	Green LEDs	Blue LEDs
LL06ED-AE08L-M2	18	16	17
LL06ED-AE25L-M2	34	31	29
LL06ED-AE40L-M2	44	44	43

The typical cone angle measures where the luminous intensity is 90% of the peak value of intensity. This typical cone varies with LED color due to different chip size and chip position tolerance.

Typical on axis intensity (cd/6w) ⁽⁴⁾ with Edixeon 1LA5			
Part Number	Red LEDs	Green LEDs	Blue LEDs
LL06ED-AE08L-M2	5760	14160	810
LL06ED-AE25L-M2	1560	5130	240
LL06ED-AE40L-M2	600	1980	120

Luminous intensity depends on the flux binning and tolerance of the LEDs. Please refer to the LEDs data sheet for more details on Flux binning and mechanical tolerance.

• Edixeon 1LA5 LED

Typical Cone Angle (degree) ⁽³⁾ with Edixeon 1LA5			
Part Number	White LEDs	Warm white LEDs	
LL06ED-AE08L-M2	24	24	
LL06ED-AE25L-M2	34	34	
LL06ED-AE40L-M2	44	46	

The typical cone angle the full angle measured where the luminous intensity is 90% of the peak value of intensity. That typical cone varies with LED color due to different chip size and chip position tolerance.

Typical on axis intensity (cd/6w) ⁽⁴⁾ with Edixeon 1LA5			
Part Number	White LEDs	Warm white LEDs	
LL06ED-AE08L-M2	7980	3420	
LL06ED-AE25L-M2	4080	1410	
LL06ED-AE40L-M2	2040	810	

Luminous intensity depends on the flux binning and tolerance of the LEDs. Please refer to the LEDs data sheet for more detail on Flux binning and mechanical tolerance

Notes:

(3) The typical divergence will be changed by different color, chip size and chip position tolerance. The typical total divergence is the full angle measured where the luminous intensity is half of the peak value.

(4) The efficiency value listed above is the total value of the whole lens model, the value depends on the total flux of the LED used. Luminous intensity depends on the LEDs flux and its tolerances, for more details of LED flux, please check Edixeon data sheet at <http://www.edison-opto.com.tw/>

Mechanical Specifications

• Usage and Maintenance :

1. If necessary, clean lenses with mild soap, water and soft cloth
2. Never use any commercial cleaning solvents on lenses, like alcohol
3. Please handle or install lenses with wearing gloves, skin oils may damage lens or its optical characteristic.

1. Lens + Leds+MCPCB assembly instruction

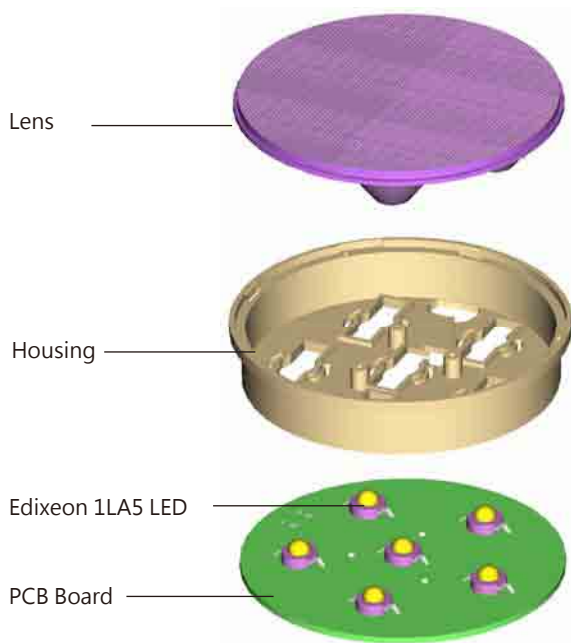

2. View assembly lens with MCPCB:

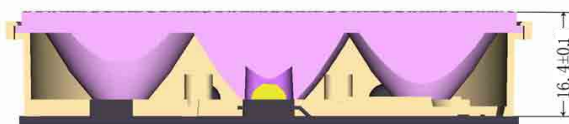

3. Lens dimensions and Top Views:

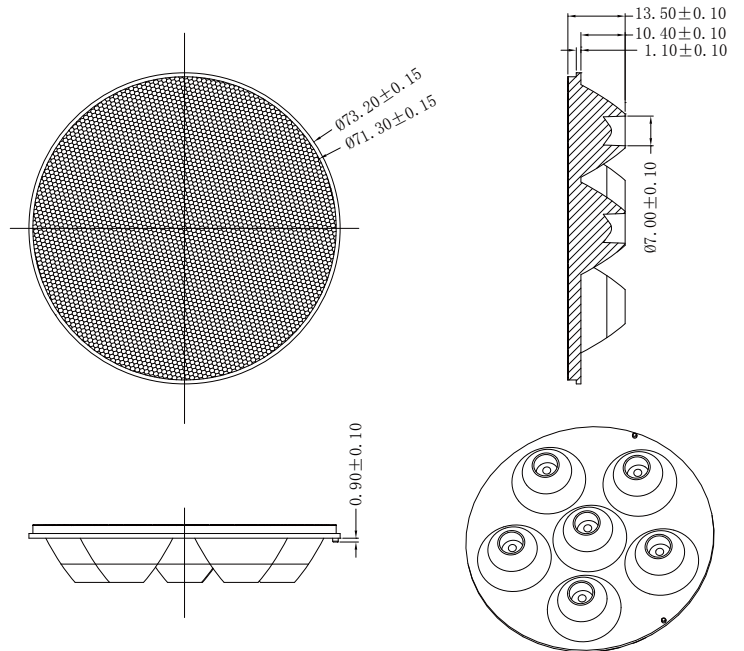

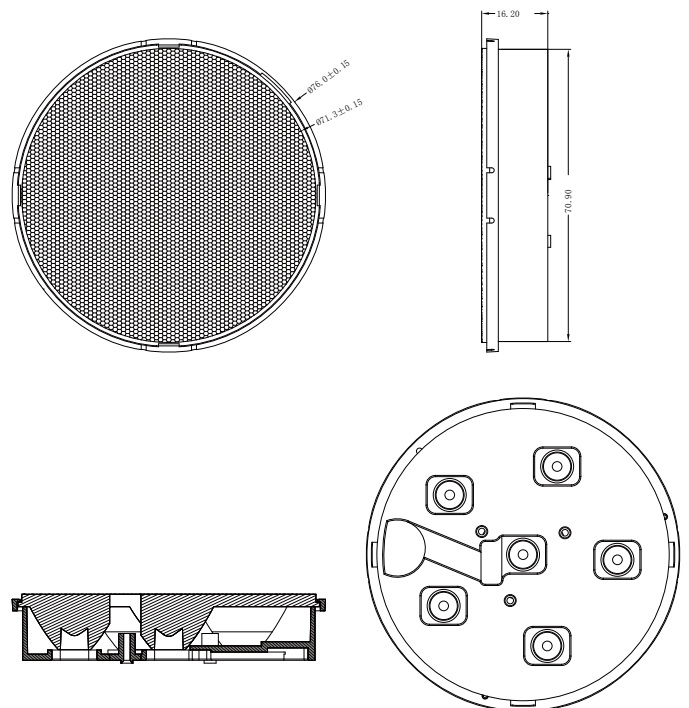

4. Lens assembly Dimensions and Top Views :



- Notes:
- (1) All dimensions are in mm.
 - (2) Drawing not to scale.
 - (3) Collimator material is PMMA.

Illumination charts

*Edixeon 6 in 1 white LED: Edixeon 1LA5

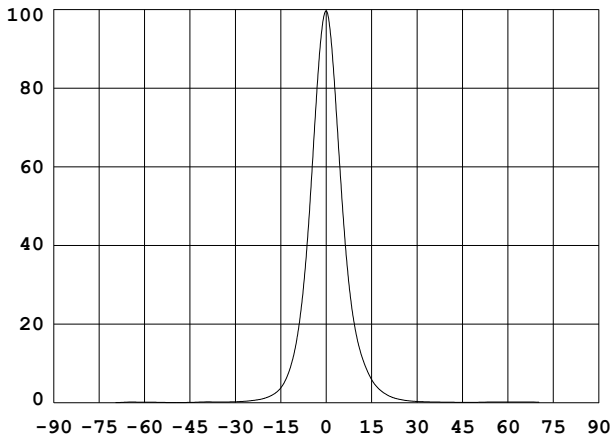
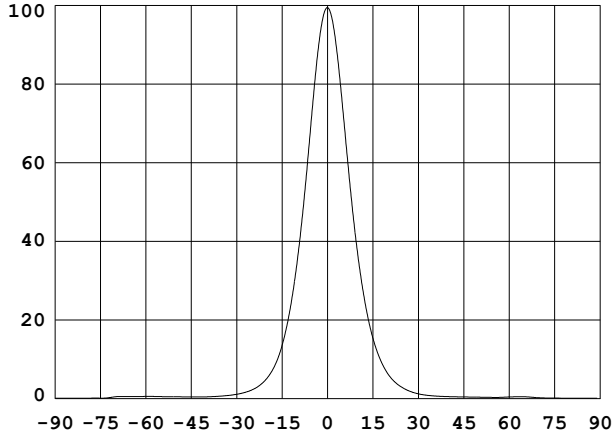
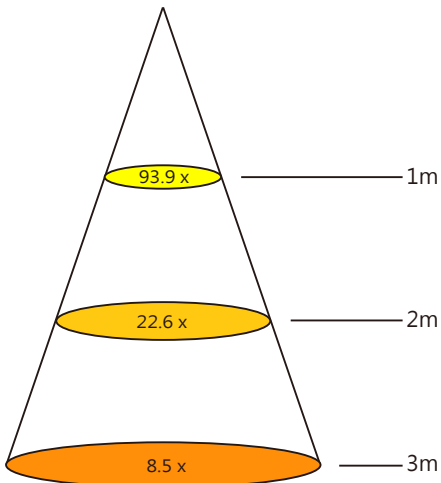
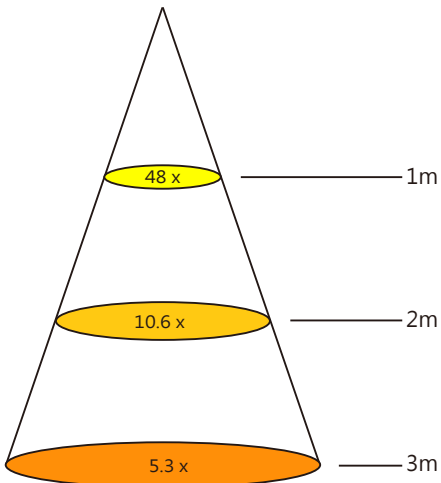
LL06ED-AE08L-M2	LL06ED-AE25L-M2
1. Beam Pattern	1. Beam Pattern
	
2. Light Distribution Curve	2. Light Distribution Curve
	
3. Illuminance	3. Illuminance
	

Notes: The Flux of Edixeon 1LA5 LED is 85 lm

Illumination charts

*Edixeon 6 in 1 white LED: Edixeon 1LA5

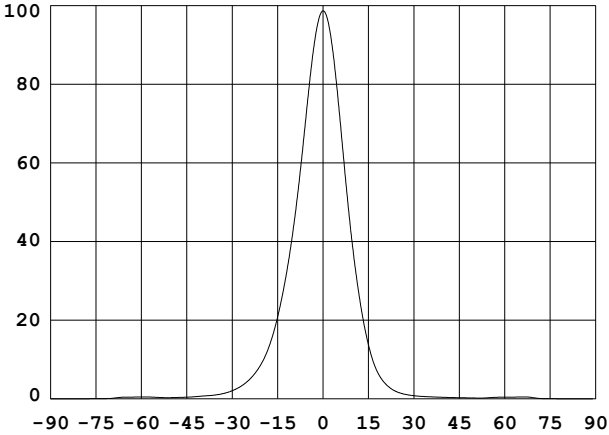
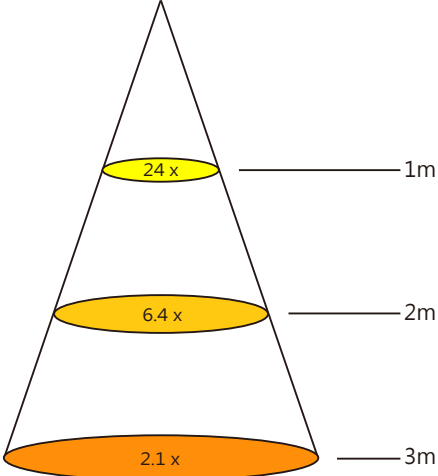
LL06ED-AE40L-M2	
1. Beam Pattern	
	
2. Light Distribution Curve	
	
3. Illuminance	
	

Notes: The Flux of Edixeon 1LA5 LED is 85 lm

Package

Item	Quantity	Total	Size (long*width* high)
Tray	16	16pcs	34*30*3.5 cm
Inner box	10tray/box	160pcs	35*31*21 cm
Outer box	2 Inner box/outer box	320pcs	64.7*36.5*24 cm

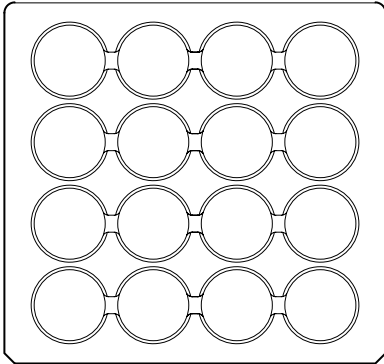

16pcs/tray

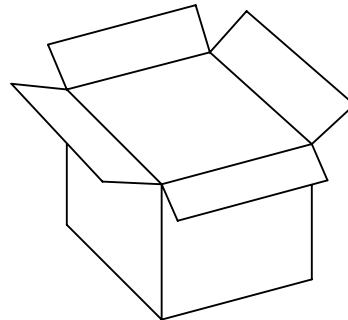
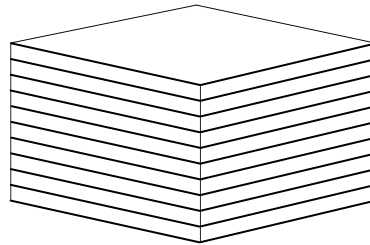

160pcs/inner box

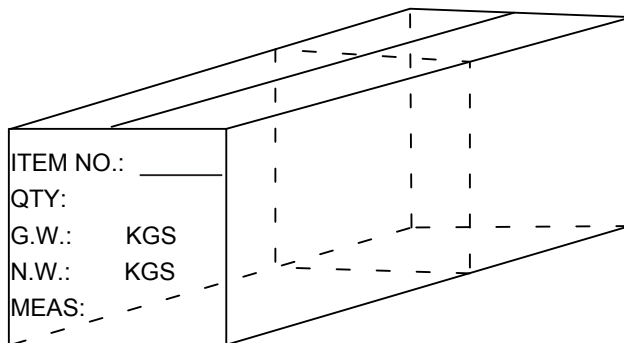

320pcs/outer box

Product Nomenclature

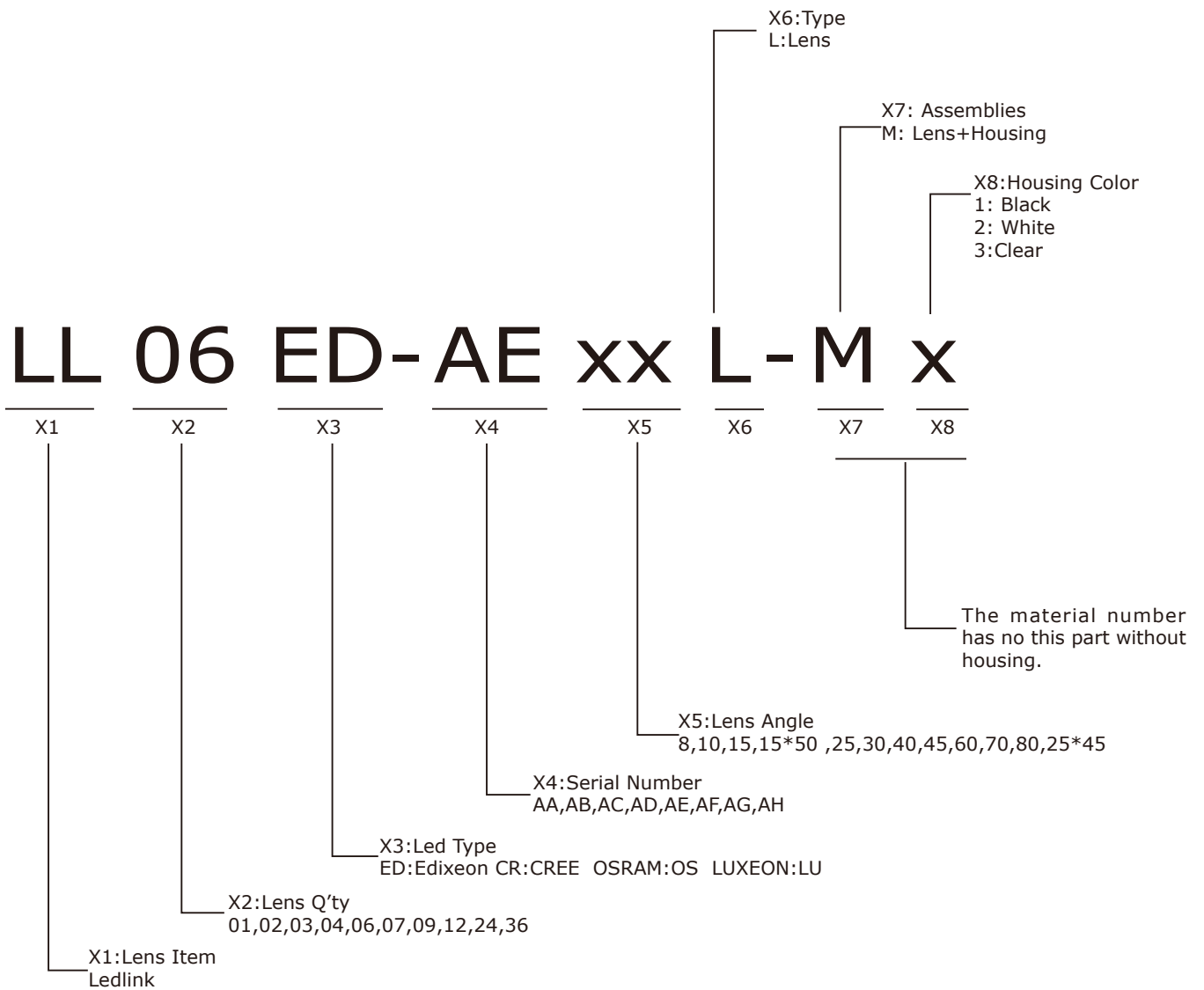

Компания «Океан Электроники» предлагает заключение долгосрочных отношений при поставках импортных электронных компонентов на взаимовыгодных условиях!

Наши преимущества:

- Поставка оригинальных импортных электронных компонентов напрямую с производств Америки, Европы и Азии, а так же с крупнейших складов мира;
- Широкая линейка поставок активных и пассивных импортных электронных компонентов (более 30 млн. наименований);
- Поставка сложных, дефицитных, либо снятых с производства позиций;
- Оперативные сроки поставки под заказ (от 5 рабочих дней);
- Экспресс доставка в любую точку России;
- Помощь Конструкторского Отдела и консультации квалифицированных инженеров;
- Техническая поддержка проекта, помощь в подборе аналогов, поставка прототипов;
- Поставка электронных компонентов под контролем ВП;
- Система менеджмента качества сертифицирована по Международному стандарту ISO 9001;
- При необходимости вся продукция военного и аэрокосмического назначения проходит испытания и сертификацию в лаборатории (по согласованию с заказчиком);
- Поставка специализированных компонентов военного и аэрокосмического уровня качества (Xilinx, Altera, Analog Devices, Intersil, Interpoint, Microsemi, Actel, Aeroflex, Peregrine, VPT, Syfer, Eurofarad, Texas Instruments, MS Kennedy, Miteq, Cobham, E2V, MA-COM, Hittite, Mini-Circuits, General Dynamics и др.);

Компания «Океан Электроники» является официальным дистрибьютором и эксклюзивным представителем в России одного из крупнейших производителей разъемов военного и аэрокосмического назначения «JONHON», а так же официальным дистрибьютором и эксклюзивным представителем в России производителя высокотехнологичных и надежных решений для передачи СВЧ сигналов «FORSTAR».



JONHON

«JONHON» (основан в 1970 г.)

Разъемы специального, военного и аэрокосмического назначения:

(Применяются в военной, авиационной, аэрокосмической, морской, железнодорожной, горно- и нефтедобывающей отраслях промышленности)

«FORSTAR» (основан в 1998 г.)

ВЧ соединители, коаксиальные кабели,
кабельные сборки и микроволновые компоненты:

(Применяются в телекоммуникациях гражданского и специального назначения, в средствах связи, РЛС, а так же военной, авиационной и аэрокосмической отраслях промышленности).



Телефон: 8 (812) 309-75-97 (многоканальный)

Факс: 8 (812) 320-03-32

Электронная почта: ocean@oceanchips.ru

Web: <http://oceanchips.ru/>

Адрес: 198099, г. Санкт-Петербург, ул. Калинина, д. 2, корп. 4, лит. А