

**PI3USB4000A**

**Ultra-High Voltage Protection USB2 1:2 Mux/DeMux**

**Features**

- Differential Bi-Directional 2:1 Mux/DeMux
- Wide Input Voltage Range: 0-5.5V
- Wide bandwidth: 1GHz
  - ◆ Ultra-low Con: 7pF
  - ◆ Ultra-low Ron: 5Ω (typ)
- Low Propagation Delay, 0.25ns typ
- Low Off-Isolation, -30dB@240MHz
- Low Crosstalk: -35dB@240MHz,
- Low Power Consumption: 35μA typical
- Wide Supply Voltage 2.7-5.5V
- Support 1.8V Logic on Control Pins
- Protection Feature
  - ◆ Off-protection for current leakage in power-down mode
  - ◆ All I/O pins are high voltage tolerance
    - C0+/C0- tolerance to 18V
    - Lx+/- tolerance to 6V
    - V<sub>DD</sub> tolerance to 9V
  - ◆ Over-voltage protection when V<sub>bus</sub> short to C0-/C0+ when device is power-on and enabled
- ESD Protection on (C0+/-)
  - ◆ IEC61000-4-2
- Wide Temperature Range: -40°C to 85°C
- Totally Lead-Free & Fully RoHS Compliant (Notes 1 & 2)
- Halogen and Antimony Free. "Green" Device (Note 3)
- Packaging (Pb-free & Green):
  - ◆ 10-contact, UQFN (ZUA10), 1.5x2mm, 0.5mm(H), 0.6mm pitch
  - ◆ 10-contact, UQFN (ZM10), 1.4x1.8mm, 0.55mm(H), 0.4mm pitch

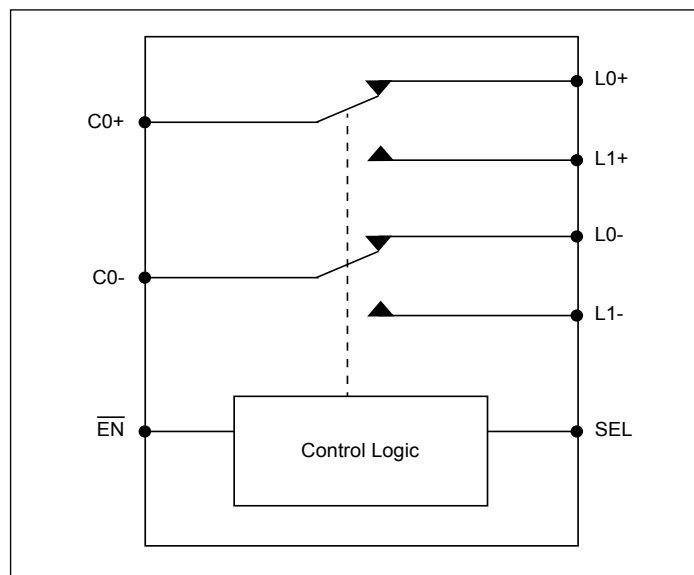
**Description**

The PI3USB4000A is a 2-to-1 differential channel multiplexer/demultiplexer switch. C0+/C0- pins can tolerate voltages up to 18V. Over-voltage protection (OVP) is implemented at 4.75V to immediately switch off the channels when over-voltage condition is detected. PI3USB4000A can pass USB2.0 signal with bandwidth 1GHz to maintain signal integrity and eye diagram open.

**Applications**

- Smart Phone, type-c application, Tablets, NB, PC

**Block Diagram**

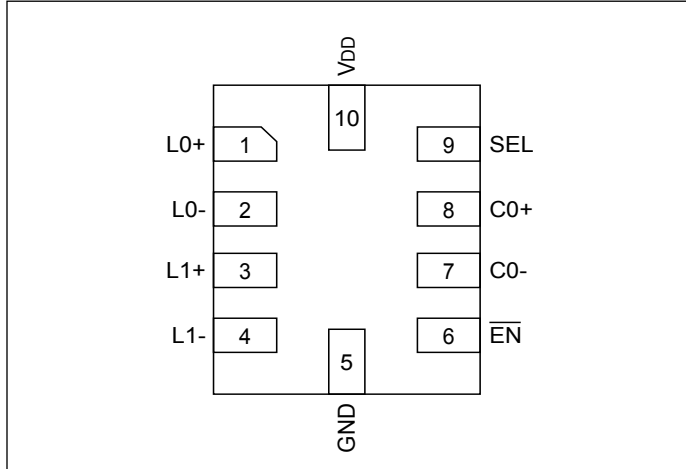


**Notes:**

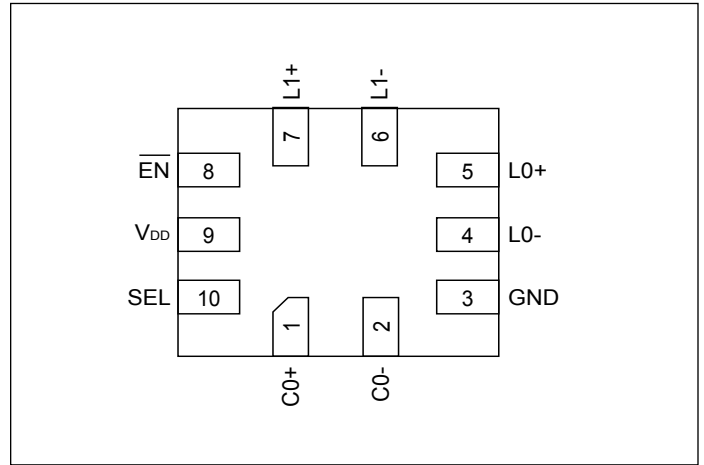
1. No purposely added lead. Fully EU Directive 2002/95/EC (RoHS), 2011/65/EU (RoHS 2) & 2015/863/EU (RoHS 3) compliant.
2. See <https://www.diodes.com/quality/lead-free/> for more information about Diodes Incorporated's definitions of Halogen- and Antimony-free, "Green" and Lead-free.
3. Halogen- and Antimony-free "Green" products are defined as those which contain <900ppm bromine, <900ppm chlorine (<1500ppm total Br + Cl) and <1000ppm antimony compounds.

**Pin Configuration**

10-UQFN Pin# (ZUA10), Top View



10-UQFN Pin# (ZM10), Top View



**Pin Description**

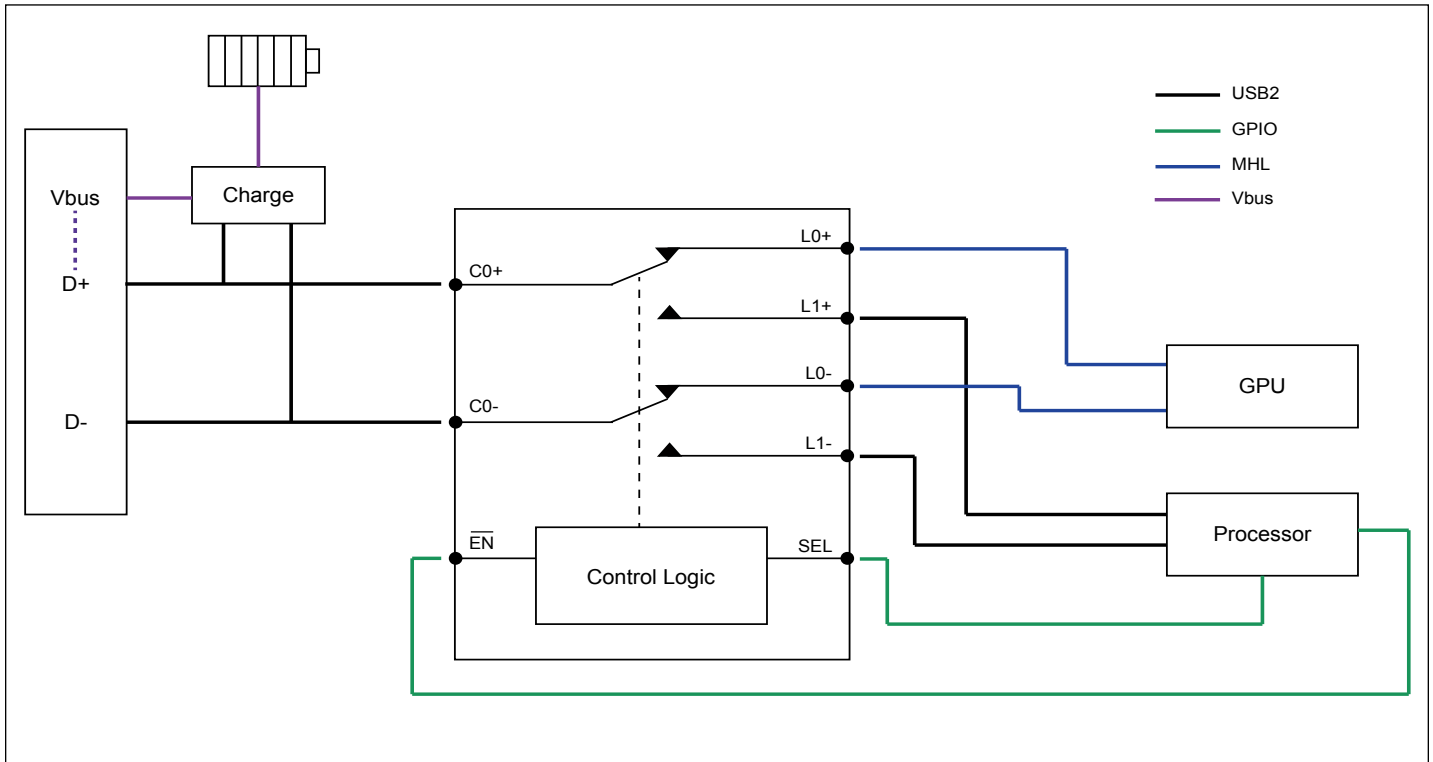
10-UQFN Pin# (ZUA10)	10-UQFN Pin# (ZM10)	Pin Name	Signal Type	Description
8, 7	1, 2	C0+, C0-	I/O	Signal I/O, Common Port
3, 4	7, 8	L1+, L1-	I/O	Signal I/O, Channel 1
1, 2	5, 4	L0+, L0-	I/O	Signal I/O, Channel 0
9	10	SEL	I	Operation mode Select (when SEL=0: C0→L0, when SEL=1: C0→L1)
6	8	EN-bar	I	EN-bar = 1, Power down is enabled. Please see Truth Table.
10	9	VDD	Pwr	Positive Supply Voltage
5	3	GND	Pwr	Power ground

**Truth Table**

Function	SEL	EN-bar
C0+/- to L0+/-	L	L
C0+/- to L1+/-	H	L
All Switches Hi-z	x	H

**PI3USB4000A**

**PI3USB4000A application in MHL Switching and provide overvoltage protection for D+/- when high voltage charging**



## Maximum Ratings

(Above which useful life may be impaired. For user guidelines, not tested.)

Storage Temperature .....	-65°C to +150°C
Supply Voltage (VDD) to Ground Potential .....	-0.3V to +9V
Channel Input/Output Voltage (Lx+/-) .....	-0.3V to +6V
Channel Input/Output Voltage (C0+/-) .....	-0.3V to +18V
Control Pins Input Voltage (EN/SEL) .....	-0.3V to +6V
ESD (All Pins).....	2KV (HBM) and 1KV (CDM)
Channel Input/Output Current (Lx/C0).....	±50mA
Junction Temperature.....	125°C

**Note:**

Stresses greater than those listed under MAXIMUM RATINGS may cause permanent damage to the device. This is a stress rating only and functional operation of the device at these or any other conditions above those indicated in the operational sections of this specification is not implied. Exposure to absolute maximum rating conditions for extended periods may affect reliability.

## Recommended Operating Conditions

Symbol	Description	Test Conditions	Min.	Typ.	Max.	Units
V <sub>DD</sub>	Power Supply		2.7	3.3	6.0	V
V <sub>IO</sub>	Analog Voltage Range		0		5.5	V
V <sub>I</sub>	Voltage Range for Control Pins		0		5.5	V
I <sub>DD</sub>	Current Consumption in Normal Operation	V <sub>DD</sub> = 3.3V, V <sub>IO</sub> = 0V, SEL = GND or V <sub>DD</sub> , EN = Low		35	45	μA
I <sub>DD_OVP</sub>	Current Consumption in OVP	V <sub>DD</sub> = 3.3V, V <sub>C0+</sub> /V <sub>C0-</sub> = 5.5V, SEL = GND or V <sub>DD</sub> , EN = Low		35		μA
I <sub>DDQ</sub>	Chip Disabled Current Consumption	V <sub>DD</sub> = 3.3V, V <sub>IO</sub> = 0V, SEL = GND or V <sub>DD</sub> , EN = High		1	2	μA
T <sub>A</sub>	Operating Temperature Range		-40		85	°C

## DC Electrical Characteristics for Switching over Operating Range

(T<sub>A</sub> = -40°C to 85°C, Typical values are at V<sub>DD</sub> = 3.3V, T<sub>A</sub> = 25°C, (unless otherwise noted))

Parameter	Description	Test Conditions	Min.	Typ.	Max.	Units
<b>Control Pins - EN/SEL</b>						
V <sub>IH</sub> - cntrl signals	Input HIGH Voltage for SEL and EN	V <sub>DD</sub> = 2.7-5.5V	1.2			V
V <sub>IL</sub> - cntrl signals	Input LOW Voltage for SEL and EN	V <sub>DD</sub> = 2.7-5.5V			0.6	V
I <sub>IH</sub>	Input HIGH Current for SEL and EN	V <sub>I</sub> = 0-5.5V	-1		1	μA
I <sub>IL</sub>	Input LOW Current for SEL and EN	V <sub>I</sub> = 0-5.5V	-1		1	μA
<b>High Speed IO - L0/L1/C0</b>						
V <sub>OVP</sub>	OVP trigger voltage		4.6	4.75	5.0	V
R <sub>on</sub>	ON resistance	V <sub>I/O</sub> = 0V, 0.4V, I <sub>on</sub> = -8 mA		5	8	Ω
Δ R <sub>on</sub>	On resistance between + and - channel	V <sub>I/O</sub> = 0V, 0.4V, I <sub>on</sub> = -8 mA		0.5	1	Ω
R <sub>on_Flat</sub>	ON resistance flatness	V <sub>I/O</sub> = 0V, 0.4V, I <sub>on</sub> = -8 mA		0.2	0.5	Ω
I <sub>off</sub>	Power-off leakage	V <sub>DD</sub> = 0V, V <sub>I/O</sub> = 0 - 3.6V	-1		1	μA
I <sub>OC</sub>	Channel off leakage current	EN = V <sub>DD</sub> = 3.3V, V <sub>I/O</sub> = 0-3.6V	-1		1	μA
I <sub>ON</sub>	Channel on leakage current	EN = 0V, V <sub>DD</sub> = 3.3V, V <sub>I/O</sub> = 0-3.6V	-1		1	μA
I <sub>OVP</sub>	Leakage current on C0+/C0- in OVP mode	EN = 0V, V <sub>DD</sub> = 3.3V, V <sub>C0+</sub> or V <sub>C0-</sub> = 14V		3	15	μA

## Dynamic Electrical Characteristics

( $T_A = -40^{\circ}\text{C}$  to  $85^{\circ}\text{C}$ , Typical values are at  $V_{DD} = 3.3\text{V}$ ,  $T_A = 25^{\circ}\text{C}$ , (unless otherwise noted))

Parameter	Description	Test Conditions	Min.	Typ.	Max.	Units
<b>Control Pins – EN/SEL</b>						
$C_I$	Input capacitance	$f=1\text{MHz}$		5		pF
<b>High Speed IO – L0/L1/C0</b>						
Con	ON Capacitance	$f=1\text{MHz}$		7		pF
Coff	OFF Capacitance	$f=1\text{MHz}$		9		pF
DDIL	Insertion Loss	$f=240\text{MHz}$		-0.5		dB
DDRL	Differential Return Loss	$f=240\text{MHz}$		-15		dB
DDOI	Differential OFF Isolation	$f=240\text{MHz}$		-30		dB
		$f=100\text{kHz}$		-80		dB
DDXT	Differential Crosstalk	$f=240\text{MHz}$		-35		dB
BW	-3dB Bandwidth			1		GHz

## Switching Characteristics<sup>(1)</sup>

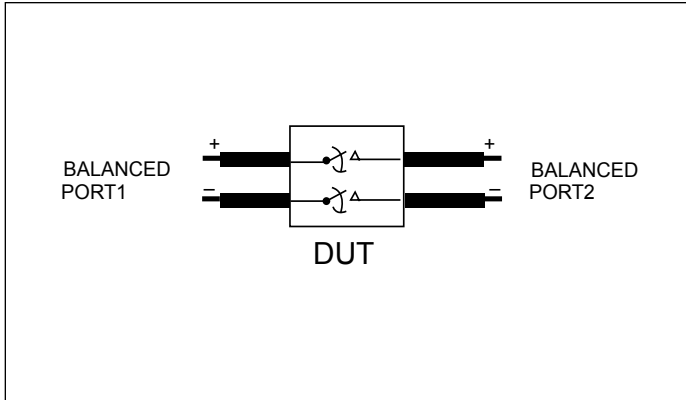
( $T_A = -40^{\circ}\text{C}$  to  $85^{\circ}\text{C}$ , Typical values are at  $V_{DD} = 3.3\text{V}$ ,  $T_A = 25^{\circ}\text{C}$ , (unless otherwise noted))

Parameter	Description	Test Conditions	Min.	Typ.	Max.	Units
$t_{OVP}$	OVP Response Time <sup>(1)</sup>	$R_{LX} = 600\Omega$ , time from the voltage on $C0_{\pm} = 4\sim 6\text{V}$ to the voltage on $LX_{\pm} = 4.75$		0.5	1	$\mu\text{s}$
$t_{PZH}, t_{PZL}$	Line Enable Time	See Test Circuit for Electrical Characteristics		20		$\mu\text{s}$
$t_{PHZ}, t_{PLZ}$	Line Disable Time			50		ns
$t_{pd}$	Propagation Delay			250		ps
$t_{b-b}$	Bit-to-bit Skew Within the Same Differential Pair <sup>(1)</sup>			8	20	ps
$T_{on}$	Device Enable Time			100		$\mu\text{s}$
$T_{off}$	Device Disable Time			50		ns

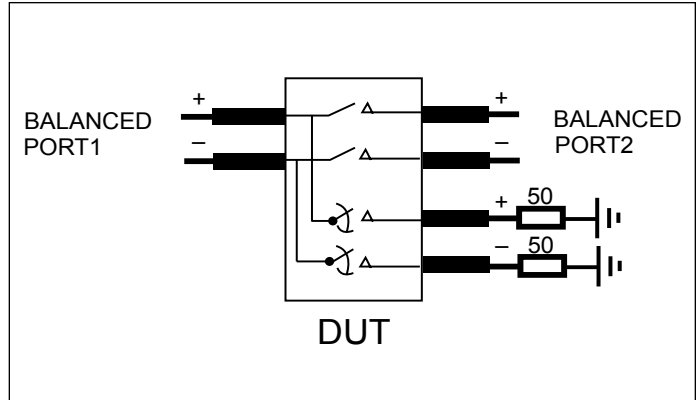
**Note:**

1. Guaranteed by design.

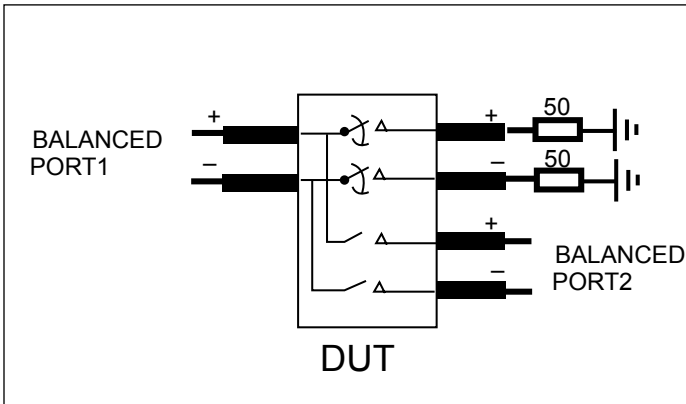
**PI3USB4000A**



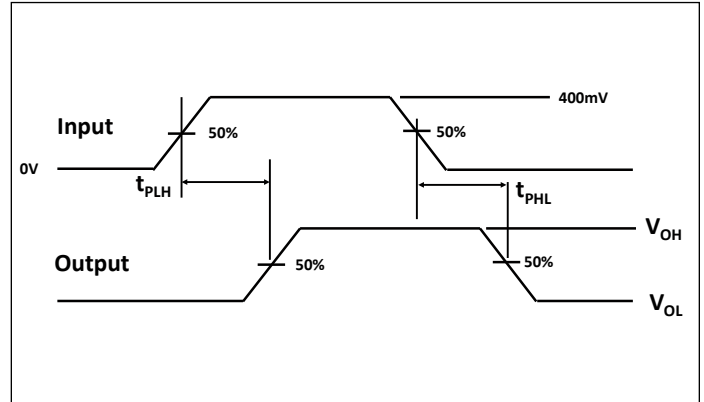
**Fig 1. Differential Insertion Loss Setup**



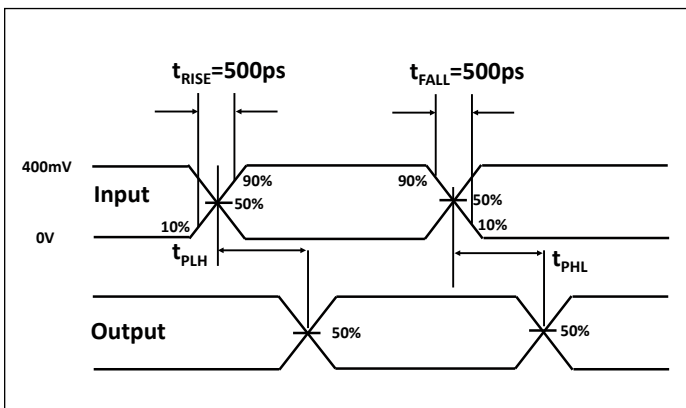
**Fig 2. Off-isolation Setup**



**Fig 3. Crosstalk Setup**

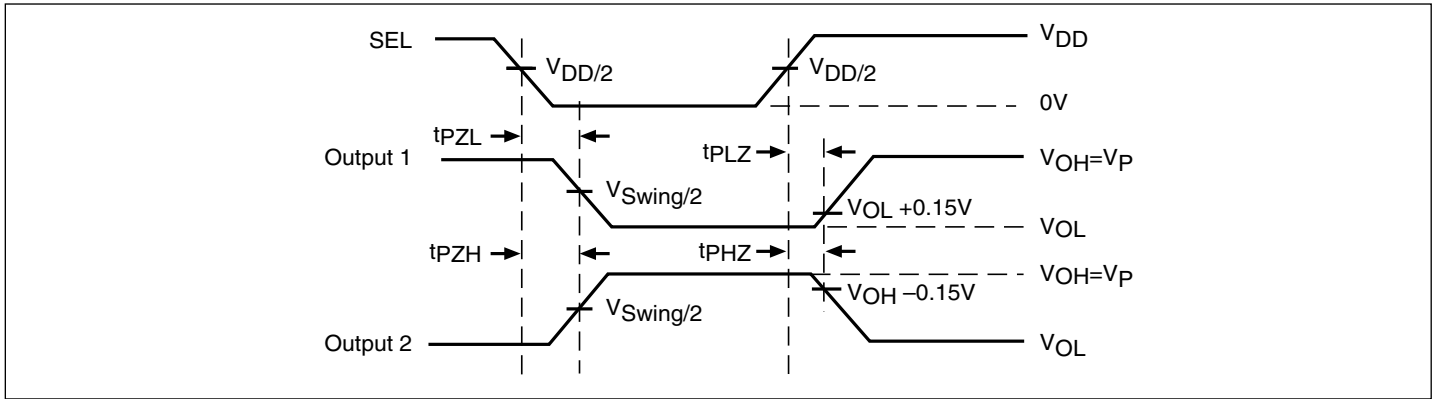


**Fig 4. Propagation Delay**



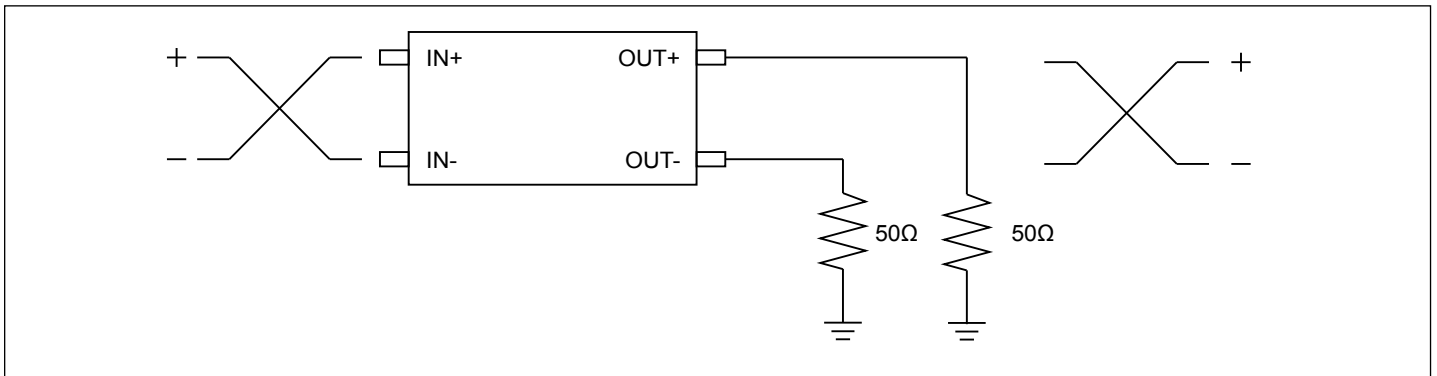
**Fig 5. Skew Test**

**Switching Waveforms**



**Voltage Waveforms Enable and Disable Times**

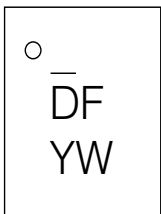
**Test Circuit for Propagation Delay**



**Part Marking**

ZM and ZUA Package

DF: PI3USB4000A

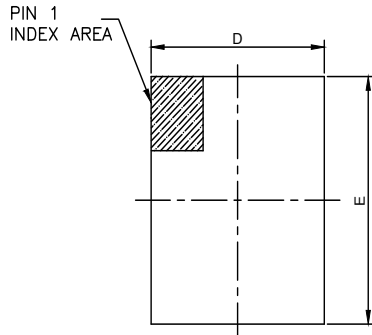


Y: Year

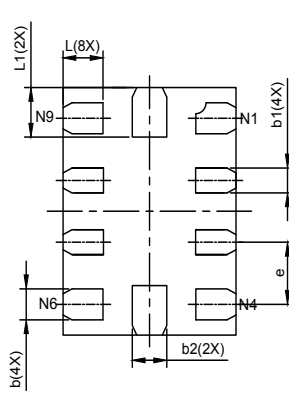
W: Workweek

**PI3USB4000A**

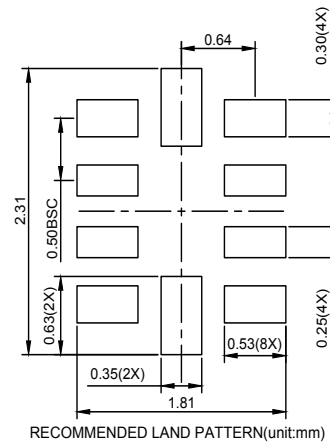
**Packaging Mechanical: 10-UQFN (ZUA)**



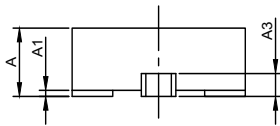
TOP VIEW



BOTTOM VIEW



RECOMMENDED LAND PATTERN(unit:mm)



SIDE VIEW

PKG. DIMENSIONS(MM)			
SYMBOL	Min	NOM	Max
A	0.50	0.60	0.65
A1	0.00	0.02	0.05
A3	0.15 REF		
D	1.45	1.50	1.55
E	1.95	2.00	2.05
b	0.20	0.25	0.30
b1	0.15	0.20	0.25
b2	0.25	0.30	0.35
e	0.50 BSC		
L	0.25	0.35	0.45
L1	0.30	0.40	0.50

**Notes:**

1. Ref: JEDEC MO-288B.

DATE: 01/06/17



DESCRIPTION: 10-Pin, UQFN, 1.5X2.0

PACKAGE CODE: ZUA(ZUA10)

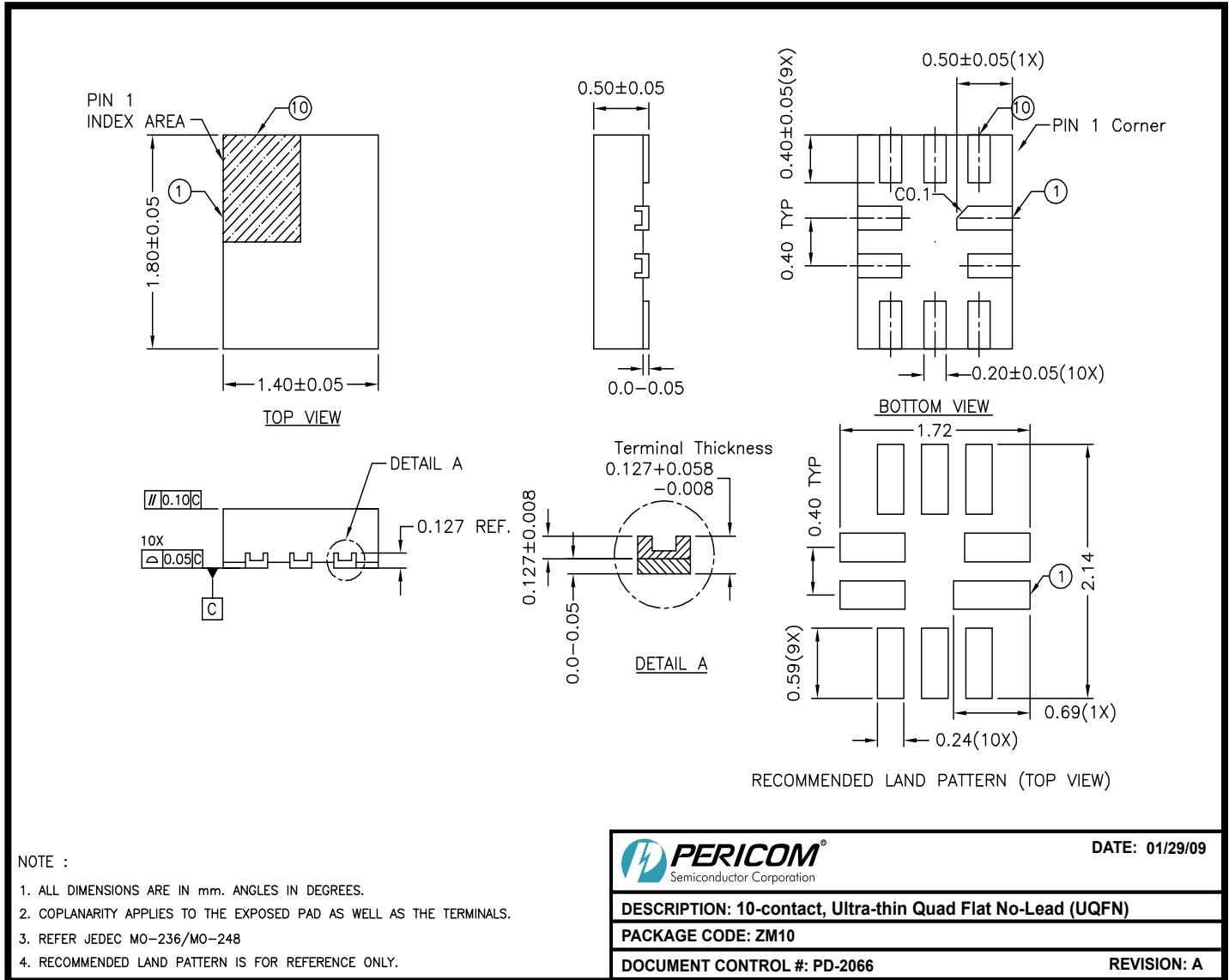
DOCUMENT CONTROL#: PD-2220

REVISION: --

17-0002



**Packaging Mechanical: 10-UQFN (ZM)**



09-0072

For latest package info.

please check: <http://www.diodes.com/design/support/packaging/pericom-packaging/packaging-mechanicals-and-thermal-characteristics/>

**Ordering Information**

Ordering Code	Package Code	Package Description
PI3USB4000AZUAEX	ZUA	10-Pin, 1.5x2.0 (UQFN)
PI3USB4000AZMEX	ZM	10-contact, Ultra-thin Quad Flat No-Lead (UQFN)

**Notes:**

1. No purposely added lead. Fully EU Directive 2002/95/EC (RoHS), 2011/65/EU (RoHS 2) & 2015/863/EU (RoHS 3) compliant.
2. See <https://www.diodes.com/quality/lead-free/> for more information about Diodes Incorporated's definitions of Halogen- and Antimony-free, "Green" and Lead-free.
3. Halogen- and Antimony-free "Green" products are defined as those which contain <900ppm bromine, <900ppm chlorine (<1500ppm total Br + Cl) and <1000ppm antimony compounds.
4. E = Pb-free and Green
5. X suffix = Tape/Reel

**IMPORTANT NOTICE**

DIODES INCORPORATED MAKES NO WARRANTY OF ANY KIND, EXPRESS OR IMPLIED, WITH REGARDS TO THIS DOCUMENT, INCLUDING, BUT NOT LIMITED TO, THE IMPLIED WARRANTIES OF MERCHANTABILITY AND FITNESS FOR A PARTICULAR PURPOSE (AND THEIR EQUIVALENTS UNDER THE LAWS OF ANY JURISDICTION).

Diodes Incorporated and its subsidiaries reserve the right to make modifications, enhancements, improvements, corrections or other changes without further notice to this document and any product described herein. Diodes Incorporated does not assume any liability arising out of the application or use of this document or any product described herein; neither does Diodes Incorporated convey any license under its patent or trademark rights, nor the rights of others. Any Customer or user of this document or products described herein in such applications shall assume all risks of such use and will agree to hold Diodes Incorporated and all the companies whose products are represented on Diodes Incorporated website, harmless against all damages.

Diodes Incorporated does not warrant or accept any liability whatsoever in respect of any products purchased through unauthorized sales channel.

Should Customers purchase or use Diodes Incorporated products for any unintended or unauthorized application, Customers shall indemnify and hold Diodes Incorporated and its representatives harmless against all claims, damages, expenses, and attorney fees arising out of, directly or indirectly, any claim of personal injury or death associated with such unintended or unauthorized application.

Products described herein may be covered by one or more United States, international or foreign patents pending. Product names and markings noted herein may also be covered by one or more United States, international or foreign trademarks.

This document is written in English but may be translated into multiple languages for reference. Only the English version of this document is the final and definitive format released by Diodes Incorporated.

**LIFE SUPPORT**

Diodes Incorporated products are specifically not authorized for use as critical components in life support devices or systems without the express written approval of the Chief Executive Officer of Diodes Incorporated. As used herein:

A. Life support devices or systems are devices or systems which:

1. are intended to implant into the body, or

2. support or sustain life and whose failure to perform when properly used in accordance with instructions for use provided in the labeling can be reasonably expected to result in significant injury to the user.

B. A critical component is any component in a life support device or system whose failure to perform can be reasonably expected to cause the failure of the life support device or to affect its safety or effectiveness.

Customers represent that they have all necessary expertise in the safety and regulatory ramifications of their life support devices or systems, and acknowledge and agree that they are solely responsible for all legal, regulatory and safety-related requirements concerning their products and any use of Diodes Incorporated products in such safety-critical, life support devices or systems, notwithstanding any devices- or systems-related information or support that may be provided by Diodes Incorporated. Further, Customers must fully indemnify Diodes Incorporated and its representatives against any damages arising out of the use of Diodes Incorporated products in such safety-critical, life support devices or systems.

Copyright © 2016, Diodes Incorporated

[www.diodes.com](http://www.diodes.com)

Компания «Океан Электроники» предлагает заключение долгосрочных отношений при поставках импортных электронных компонентов на взаимовыгодных условиях!

Наши преимущества:

- Поставка оригинальных импортных электронных компонентов напрямую с производств Америки, Европы и Азии, а так же с крупнейших складов мира;
- Широкая линейка поставок активных и пассивных импортных электронных компонентов (более 30 млн. наименований);
- Поставка сложных, дефицитных, либо снятых с производства позиций;
- Оперативные сроки поставки под заказ (от 5 рабочих дней);
- Экспресс доставка в любую точку России;
- Помощь Конструкторского Отдела и консультации квалифицированных инженеров;
- Техническая поддержка проекта, помощь в подборе аналогов, поставка прототипов;
- Поставка электронных компонентов под контролем ВП;
- Система менеджмента качества сертифицирована по Международному стандарту ISO 9001;
- При необходимости вся продукция военного и аэрокосмического назначения проходит испытания и сертификацию в лаборатории (по согласованию с заказчиком);
- Поставка специализированных компонентов военного и аэрокосмического уровня качества (Xilinx, Altera, Analog Devices, Intersil, Interpoint, Microsemi, Actel, Aeroflex, Peregrine, VPT, Syfer, Eurofarad, Texas Instruments, MS Kennedy, Miteq, Cobham, E2V, MA-COM, Hittite, Mini-Circuits, General Dynamics и др.);

Компания «Океан Электроники» является официальным дистрибьютором и эксклюзивным представителем в России одного из крупнейших производителей разъемов военного и аэрокосмического назначения «JONHON», а так же официальным дистрибьютором и эксклюзивным представителем в России производителя высокотехнологичных и надежных решений для передачи СВЧ сигналов «FORSTAR».



## JONHON

«JONHON» (основан в 1970 г.)

Разъемы специального, военного и аэрокосмического назначения:

(Применяются в военной, авиационной, аэрокосмической, морской, железнодорожной, горно- и нефтедобывающей отраслях промышленности)

«FORSTAR» (основан в 1998 г.)

ВЧ соединители, коаксиальные кабели, кабельные сборки и микроволновые компоненты:

(Применяются в телекоммуникациях гражданского и специального назначения, в средствах связи, РЛС, а так же военной, авиационной и аэрокосмической отраслях промышленности).



Телефон: 8 (812) 309-75-97 (многоканальный)

Факс: 8 (812) 320-03-32

Электронная почта: [ocean@oceanchips.ru](mailto:ocean@oceanchips.ru)

Web: <http://oceanchips.ru/>

Адрес: 198099, г. Санкт-Петербург, ул. Калинина, д. 2, корп. 4, лит. А