



Is Now Part of



**ON Semiconductor®**

To learn more about ON Semiconductor, please visit our website at  
[www.onsemi.com](http://www.onsemi.com)

Please note: As part of the Fairchild Semiconductor integration, some of the Fairchild orderable part numbers will need to change in order to meet ON Semiconductor's system requirements. Since the ON Semiconductor product management systems do not have the ability to manage part nomenclature that utilizes an underscore (\_), the underscore (\_) in the Fairchild part numbers will be changed to a dash (-). This document may contain device numbers with an underscore (\_). Please check the ON Semiconductor website to verify the updated device numbers. The most current and up-to-date ordering information can be found at [www.onsemi.com](http://www.onsemi.com). Please email any questions regarding the system integration to [Fairchild\\_questions@onsemi.com](mailto:Fairchild_questions@onsemi.com).

ON Semiconductor and the ON Semiconductor logo are trademarks of Semiconductor Components Industries, LLC dba ON Semiconductor or its subsidiaries in the United States and/or other countries. ON Semiconductor owns the rights to a number of patents, trademarks, copyrights, trade secrets, and other intellectual property. A listing of ON Semiconductor's product/patent coverage may be accessed at [www.onsemi.com/site/pdf/Patent-Marking.pdf](http://www.onsemi.com/site/pdf/Patent-Marking.pdf). ON Semiconductor reserves the right to make changes without further notice to any products herein. ON Semiconductor makes no warranty, representation or guarantee regarding the suitability of its products for any particular purpose, nor does ON Semiconductor assume any liability arising out of the application or use of any product or circuit, and specifically disclaims any and all liability, including without limitation special, consequential or incidental damages. Buyer is responsible for its products and applications using ON Semiconductor products, including compliance with all laws, regulations and safety requirements or standards, regardless of any support or applications information provided by ON Semiconductor. "Typical" parameters which may be provided in ON Semiconductor data sheets and/or specifications can and do vary in different applications and actual performance may vary over time. All operating parameters, including "Typicals" must be validated for each customer application by customer's technical experts. ON Semiconductor does not convey any license under its patent rights nor the rights of others. ON Semiconductor products are not designed, intended, or authorized for use as a critical component in life support systems or any FDA Class 3 medical devices or medical devices with a same or similar classification in a foreign jurisdiction or any devices intended for implantation in the human body. Should Buyer purchase or use ON Semiconductor products for any such unintended or unauthorized application, Buyer shall indemnify and hold ON Semiconductor and its officers, employees, subsidiaries, affiliates, and distributors harmless against all claims, costs, damages, and expenses, and reasonable attorney fees arising out of, directly or indirectly, any claim of personal injury or death associated with such unintended or unauthorized use, even if such claim alleges that ON Semiconductor was negligent regarding the design or manufacture of the part. ON Semiconductor is an Equal Opportunity/Affirmative Action Employer. This literature is subject to all applicable copyright laws and is not for resale in any manner.

# FDMF6704V - XST™ DrMOS

The Xtra Small, High Performance, High Frequency DrMOS Module with LDO

## Benefits

- Single 12 V power supply operation.
- Ultra compact size - 6 mm x 6 mm MLP, 44 % space saving compared to conventional MLP 8 mm x 8 mm DrMOS packages.
- Ultra compact thermally enhanced 6 mm x 6 mm MLP package 84 % smaller than conventional discrete solutions.
- Fully optimized system efficiency.
- Clean voltage waveforms with reduced ringing.
- High frequency operation.
- Compatible with a wide variety of PWM controllers in the market.
- Single input voltage operation.

## Features

- Internal 12 V to 5 V regulator.
- Synchronous driver plus FET multichip module.
- High current handling of 35 A.
- Over 93 % peak efficiency.
- Tri-State PWM input.
- Fairchild's PowerTrench® 5 technology MOSFETs for clean voltage waveforms and reduced ringing.
- Optimized for high switching frequencies of up to 1 MHz.
- Skip mode SMOD [low side gate turn off] input.
- Fairchild SyncFET™ [integrated Schottky diode] technology in the low side MOSFET.
- Integrated bootstrap Schottky diode.
- Adaptive gate drive timing for shoot-through protection.
- Driver output disable function [DISB# pin].
- Undervoltage lockout (UVLO).
- Fairchild Green Packaging and RoHS compliant. Low profile SMD package.



## General Description

The XST™ DrMOS family is Fairchild's next-generation fully-optimized, ultra-compact, integrated MOSFET plus driver power stage solutions for high current, high frequency synchronous buck DC-DC applications. The FDMF6704V XST™ DrMOS integrates a driver IC, two power MOSFETs and a bootstrap Schottky diode along with an integrated 5 V gate drive LDO regulator into a thermally enhanced, ultra compact 6 mm x 6 mm MLP package. With an integrated approach, the complete switching power stage is optimized with regards to driver and MOSFET dynamic performance, system inductance and  $R_{DS(ON)}$ . This greatly reduces the package parasitics and layout challenges associated with conventional discrete solutions. XST™ DrMOS uses Fairchild's high performance PowerTrench™ 5 MOSFET technology, which dramatically reduces ringing in synchronous buck converter applications. PowerTrench™ 5 can eliminate the need for a snubber circuit in buck converter applications. The driver IC incorporates advanced features such as SMOD for improved light load efficiency and a Tri-State PWM input for compatibility with a wide range of PWM controllers. A 5 V gate drive and an improved PCB interface, optimized for a maximum low side FET exposed pad area, ensure higher performance. This product is compatible with the new Intel 6 mm x 6 mm DrMOS specification.

## Applications

- Compact blade servers V-core, non V-core and VTT DC-DC converters.
- Desktop computers V-core, non V-core and VTT DC-DC converters.
- Workstations V-core, non V-core and VTT DC-DC converters.
- Gaming Motherboards V-core, non V-core and VTT DC-DC converters.
- Gaming consoles.
- High-current DC-DC Point of Load (POL) converters.
- Networking and telecom microprocessor voltage regulators.

## Power Train Application Circuit

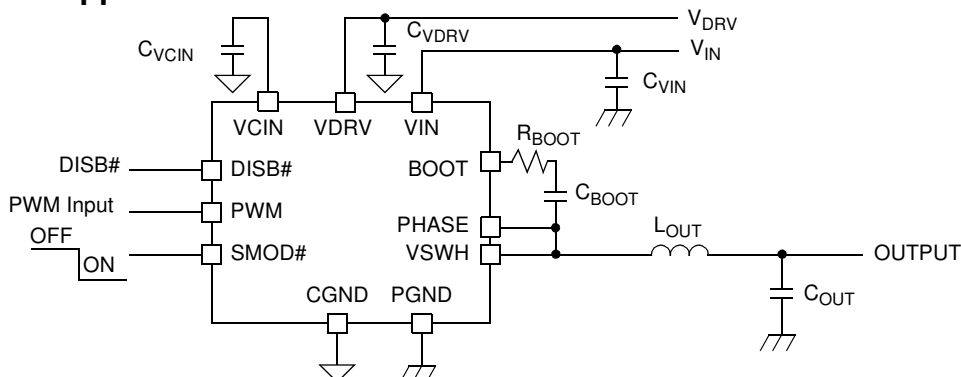

Figure 1. Power Train Application Circuit

## Ordering Information

Order Number	Marking	Temperature Range	Device Package	Packing Method	Quantity
FDMF6704V	FDMF6704V_1	-55 °C to 150 °C	40 Pin, 3 DAP, MLP 6x6 mm	Tape and Reel	3000

## Functional Block Diagram

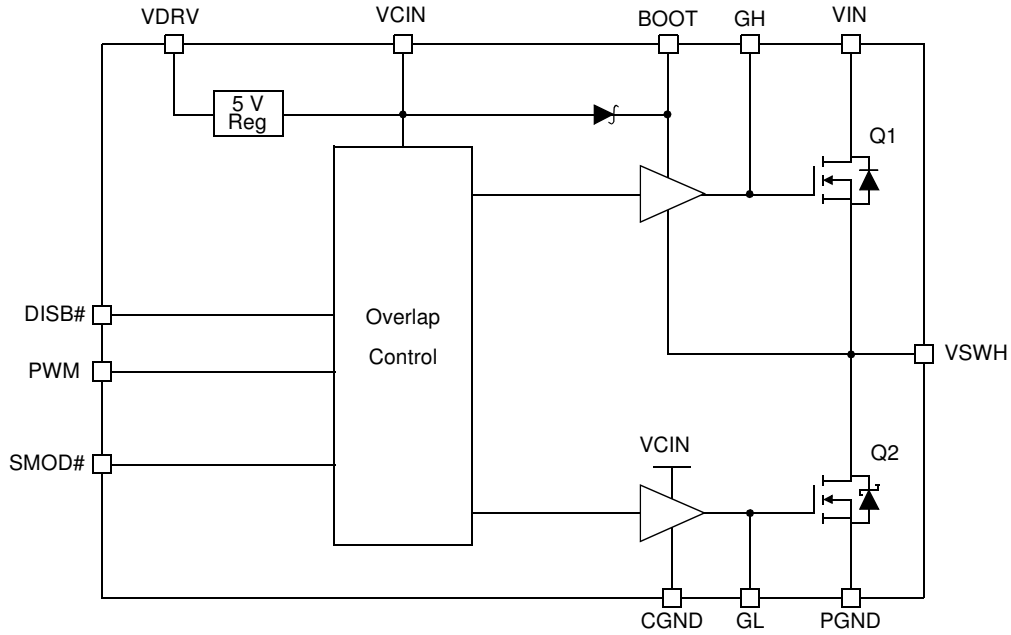

Figure 2. Functional Block Diagram

## Pin Configuration

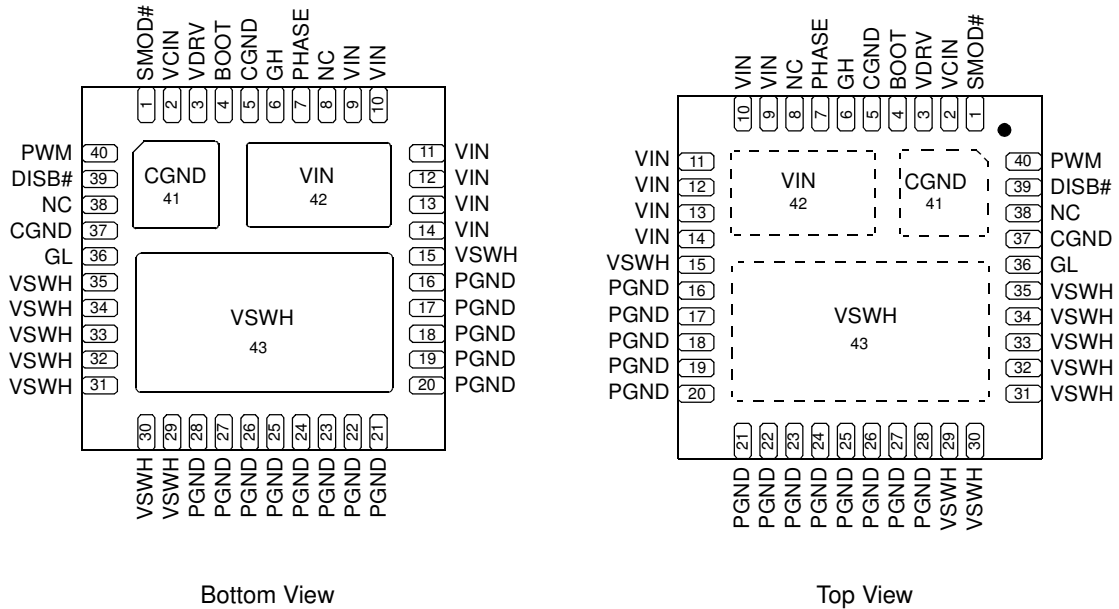

Figure 3. 6mm x 6mm, 40L MLP

## Pin Description

Pin	Name	Function
1	SMOD#	When SMOD# = HI, low side driver is inverse of PWM input. When SMOD# = Low, low side driver is disabled. This pin has no internal pullup or pulldown. It should not be left floating. Do not add noise filter cap.
2	VCIN	Regulator 5 V Output. Power for gate drives and logic. A minimum 4.7 $\mu$ F X7R ceramic capacitor is required to be connected from this pin to CGND.
3	VDRV	Regulator Input Voltage. A minimum 4.7 $\mu$ F X7R ceramic capacitor is required to be connected from this pin to CGND.
4	BOOT	Bootstrap Supply Input. Provides voltage supply to high-side MOSFET driver. Connect bootstrap capacitor from this pin to PHASE.
5, 37, 41	CGND	IC Ground. Ground return for driver IC.
6	GH	For manufacturing test only. This pin must be floated. Must not be connected to any pin.
7	PHASE	Switch node pin for easy bootstrap capacitor routing. Electrically shorted to VSWH pin.
8, 38	NC	Not Connected Internally.
9-14, 42	VIN	Power input. Output stage supply voltage.
15, 29-35, 43	VSWH	Switch Node Output. Provides return for high-side bootstrapped driver and acts as a sense point for the adaptive shoot-thru protection.
16-28	PGND	Power Ground. Output stage ground. Source pin of low side MOSFET(s).
36	GL	For manufacturing test only. This pin must be floated. Must not be connected to any pin.
39	DISB#	Output disable. When low, this pin disable FET switching (GH and GL are held low). This pin has no internal pullup or pulldown. It should not be left floating. Do not add noise filter cap.
40	PWM	PWM Signal Input. This pin accepts a Tri-state logic-level PWM signal from the controller. Do not add noise filter cap.

## Absolute Maximum Rating

Parameter	Min	Max	Units	
VCIN, DISB#, PWM, SMOD#, GL to CGND		6	V	
VIN to PGND, CGND		27	V	
VDRV to PGND, CGND		16	V	
BOOT, GH to VSWH, PHASE		6	V	
BOOT, VSWH, PHASE, GH to GND		27	V	
BOOT to VCIN		22	V	
$I_{O(AV)}$ *	$V_{IN} = 12\text{ V}, V_O = 1.3\text{ V}$	$f_{SW} = 350\text{ kHz}$	35	A
		$f_{SW} = 1\text{ MHz}$	32	A
$I_{O(peak)}$ *		80	A	
$R_{\theta JB}$	Thermal Resistance Junction to Board	3.75	$^{\circ}\text{C}/\text{W}$	
Operating and Storage Junction Temperature Range		-55	150	$^{\circ}\text{C}$

\*  $I_{O(AV)}$  and  $I_{O(peak)}$  are measured in FCS evaluation board. These ratings can be changed with different application setting.

## Recommended Operating Range

Parameter	Min	Typ	Max	Units		
$V_{DRV}$	Vgate and Logic Supply Voltage		8	12	14	V
$V_{IN}$	Output FET Supply Voltage		3*	12	14	V

\* May be operated at lower input voltage. See figure 10.

## Electrical Characteristics

$V_{IN} = 12\text{ V}$ ,  $V_{DRV} = 12\text{ V}$ ,  $T_A = 25\text{ °C}$  unless otherwise noted.

Parameter	Symbol	Conditions	Min	Typ	Max	Units
Operating Quiescent Current	IQ	PWM = GND			2	mA
		PWM = $V_{CIN}$			2	
<b>Internal 5V Regulator</b>						
Input Voltage	$V_{DRV}$		8		14	V
Input Current	$I_{VDRV}$	$8\text{V} < V_{IN} < 14\text{V}$ , 1MHz		36		mA
Output voltage	$V_{CIN}$	$V_{DRV} = 8\text{V}$ , $I_{Load} = 5\text{mA}$	4.8	5	5.2	V
Power Dissipation	$P_{VDRV}$	$V_{DRV} = 12\text{V}$ , 1MHz		250		mW
VCIN Capacitor	$C_{VCIN}$	X7R Ceramic	4.7		10	$\mu\text{F}$
Line Regulation		$8\text{V} < V_{DRV} < 14\text{V}$ , $I_{Load} = 5\text{mA}$		20		mV
Load Regulation		$V_{DRV} = 8\text{V}$ , $5\text{mA} < I_{Load} < 100\text{mA}$		75		mV
Short Circuit Current Limit				200		mA
UVLO Threshold				7.5		V
UVLO COMP Hysteresis				0.5		V
<b>PWM Input</b>						
Sink Impedance		PWM to GND		10		k $\Omega$
Source Impedance		PWM to $V_{CIN}$		10		k $\Omega$
Tri-State Rising Threshold			3.2	3.4	3.6	V
Tri-State Rising Hysteresis				100		mV
Tri-State Falling Threshold			1.2	1.4	1.6	V
Tri-State Falling Hysteresis				100		mV
Tri-State Pin Open				2.5		V
Tri-State Shut Off Time				100		ns
<b>SMOD# and DISB# Input</b>						
High Level Input Voltage			2			V
Low Level Input Voltage					0.8	V
Input Bias Current			-2		2	$\mu\text{A}$
Propagation Delay Time		PWM = GND, delay between SMOD# or DISB# from HI to LO to GL from HI to LO.		15		ns
<b>High Side Driver</b>						
Rise Time		10 % to 90 %		25		ns
Fall Time		90 % to 10 %		20		ns
Deadband Time	$t_{DTHH}$	GL going LO to GH going HI, 10 % to 10 %		25		ns
Propagation Delay	$t_{PDHL}$	PMW going LO to GH going LO		10		ns
<b>Low Side Driver</b>						
Rise Time		10 % to 90 %		25		ns
Fall Time		90 % to 10 %		20		ns
Deadband Time	$t_{DTLH}$	VSWH going LO to GL going HI, 10 % to 10 %		20		ns
Propagation Delay	$t_{PDLL}$	PWM going HI to GL going LO		10		ns
<b>250 ns Time Out Circuit</b>						
250 ns Time Delay		Delay between GH from HI to LO and GL from LO to HI if VSWH is high.		250		ns

## Description of Operation

### Circuit Description

The FDMF6704V is a driver plus FET module incorporating an internal 12 V to 5 V regulator that is optimized for synchronous buck converter topology. A single PWM input signal is all that is required to properly drive the high-side and the low-side MOSFETs at speeds up to 1 MHz.

### PWM

When the PWM input goes high, the high side MOSFET turns on. When it goes low, the low side MOSFET turns on. When it is open, both the low side and high side MOSFET will turn off. The individual PWM signals from the controller will be used to dynamically enable or disable individual phases.

### DISB#

The DISB# input is combined with the PWM signal to control the driver output. In a typical multiphase design, DISB# will be a common signal used to turn on all phases.

### Gate Low

The low-side driver (GL) is designed to drive a ground referenced low  $R_{DS(ON)}$  N-channel MOSFET. The bias for GL is internally connected between VCIN and CGND. When the driver is enabled, the driver's output is 180° out of phase with the PWM input. When the driver is disabled (DISB# = 0 V), GL is held low turning the low side FET off.

### Gate High

The high-side driver (GH) is designed to drive a floating N-channel MOSFET. The bias voltage for the high-side driver is developed by a bootstrap supply circuit, consisting of the internal BOOT diode and an external bootstrap capacitor ( $C_{BOOT}$ ). During start-up, VSWH is held at PGND, allowing  $C_{BOOT}$  to charge to  $V_{CIN}$  through the internal diode. When the PWM input goes high, GH will begin to charge the high-side MOSFET's gate (Q1). During this transition, charge is removed from  $C_{BOOT}$  and delivered to Q1's gate. As Q1 turns on, VSWH rises to  $V_{IN}$ , forcing the BOOT pin to  $V_{IN} + V_{C(BOOT)}$ , which provides sufficient  $V_{GS}$  enhancement for Q1. To complete the switching cycle, Q1 is turned off by pulling GH to VSWH.  $C_{BOOT}$  is then recharged to VCIN when VSWH falls to PGND. GH output is in phase with the PWM input. When the driver is disabled, the high-side FET is turned off.

### VDRV and VCIN

The FDMF6704V incorporates an internal 12 V to 5 V regulator to allow it to be used in single 12 V supply applications.

The regulator's 5V output (VCIN) is connected to pin 2 and used internally to supply power to the gate drives and to the internal logic. A 4.7µF X7R ceramic capacitor must be connected between VCIN and ground. This capacitor is part of the regulator's loop compensation so a high X7R type is required.

The regulator's input VDRV is connected to pin 3.

### SMOD#

The SMOD (Skip Mode) function allows for higher converter efficiency under light load conditions. During SMOD, the LS FET is disabled and it prevents discharging of output caps. When the SMOD# pin is pulled high, the sync buck converter will work in synchronous mode. When the SMOD# pin is pulled low, the LS FET is turned off. The SMOD function does not have internal current sensing. This SMOD# pin is connected to a PWM controller which enables or disables the SMOD automatically when the controller detects light load condition. This pin is Active Low.

### Adaptive Gate Drive Circuit

The driver IC embodies an advanced design that ensures minimum MOSFET dead-time while eliminating potential shoot-through (cross-conduction) currents. It senses the state of the MOSFETs and adjusts the gate drive, adaptively, to ensure they do not conduct simultaneously. Refer to Figure 4 for the relevant timing waveforms.

To prevent overlap during the low-to-high switching transition (Q2 OFF to Q1 ON), the adaptive circuitry monitors the voltage at the GL pin. When the PWM signal goes HIGH, Q2 will begin to turn OFF after some propagation delay ( $t_{PDLL}$ ). Once the GL pin is discharged below 1 V, Q1 begins to turn ON after adaptive delay  $t_{DTLH}$ .

To preclude overlap during the high-to-low transition (Q1 OFF to Q2 ON), the adaptive circuitry monitors the voltage at the VSWH pin. When the PWM signal goes LOW, Q1 will begin to turn OFF after some propagation delay ( $t_{PDHL}$ ). Once the VSWH pin falls below 1 V, Q2 begins to turn ON after adaptive delay  $t_{DTLH}$ .

Additionally,  $V_{GS}$  of Q1 is monitored. When  $V_{GS(Q1)}$  is discharged low, a secondary adaptive delay is initiated, which results in Q2 being driven ON after 250 ns, regardless of VSWH state. This function is implemented to ensure  $C_{BOOT}$  is recharged each switching cycle, particularly for cases where the power converter is sinking current and VSWH voltage does not fall below the 1 V adaptive threshold. The 250 ns secondary delay is longer than  $t_{DTLH}$ .

## Timing Diagrams

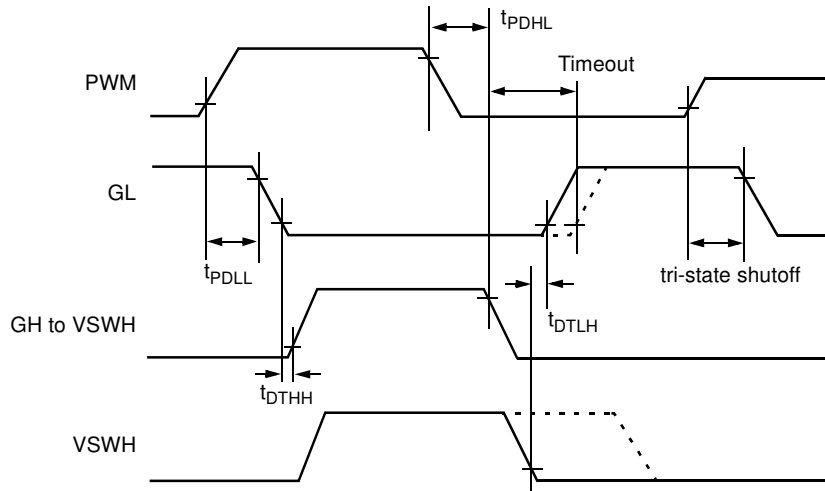

Figure 4. Timing Diagram

## Switch Node Ringing Suppression

Fairchild's DrMOS products have proprietary feature\* that minimizes the peak overshoot and ringing voltage on the switch node (VSWH) output, without the need of external snubbers. The following pictures show the waveforms of an FDMF6704 DrMOS part and a competitor's part tested without snubbing. The tests were done in the same test circuit, under the same operating conditions.

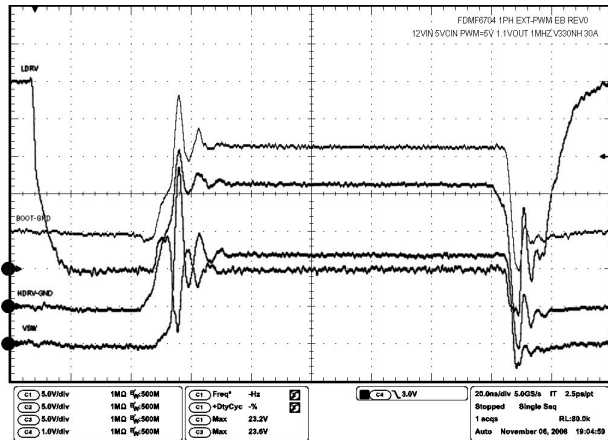

Figure 5. FDMF6704

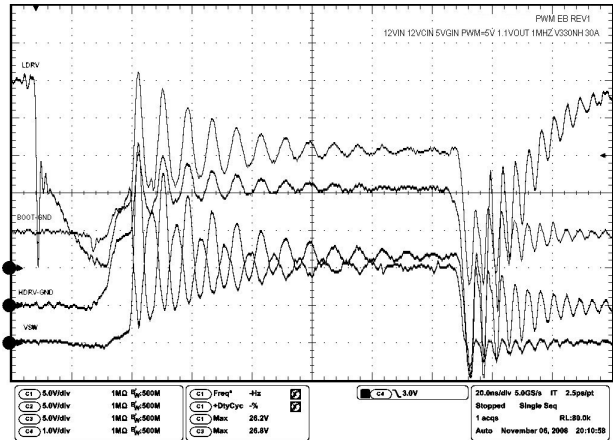

Figure 6. Competitor Part

\* Patent Pending

## Typical Characteristics

$V_{IN} = 12V$ ,  $V_{DRV} = 12V$ ,  $T_A = 25^\circ C$  unless otherwise noted.

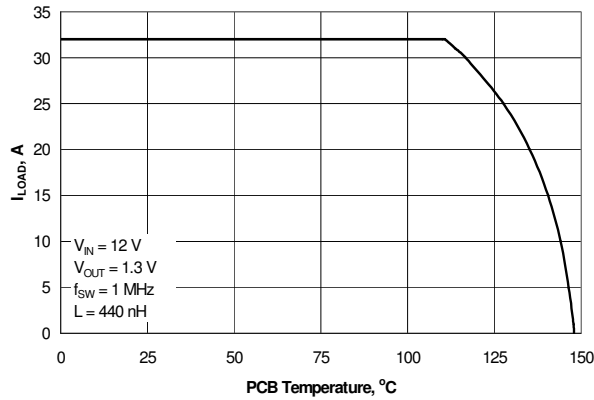

Figure 7. Safe Operating Area

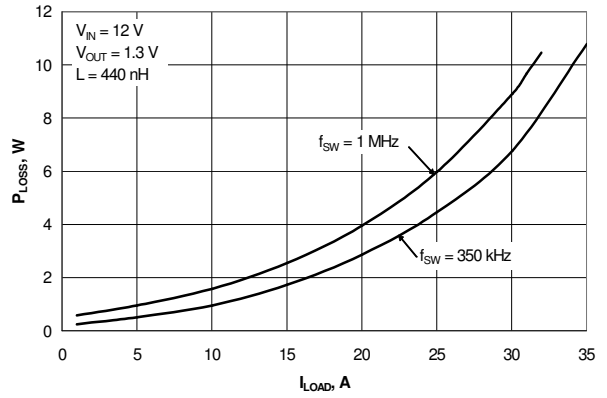

Figure 8. Module Power Loss vs. Output Current  
(Note: For total power loss, add 5 V regulator loss shown in Figure 18 on page 8.)

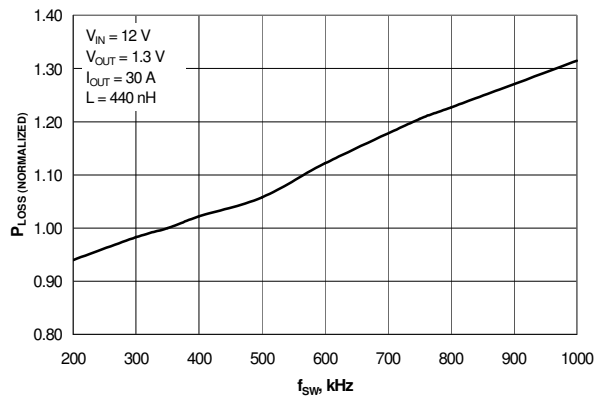

Figure 9. Normalized Power Loss vs. Switching Frequency

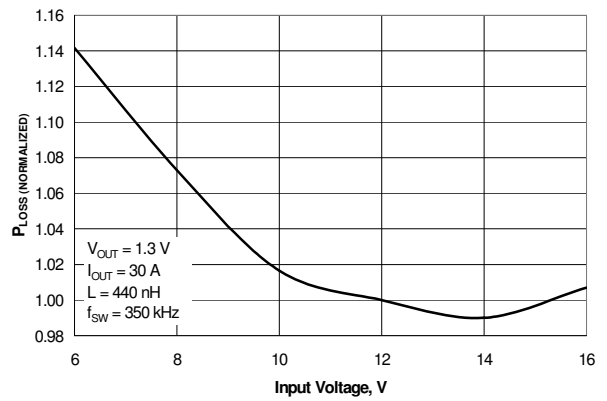

Figure 10. Normalized Power Loss vs. Input Voltage

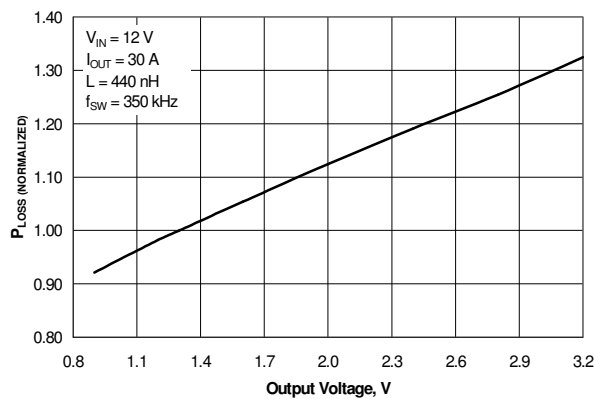

Figure 11. Normalized Power Loss vs. Output Voltage

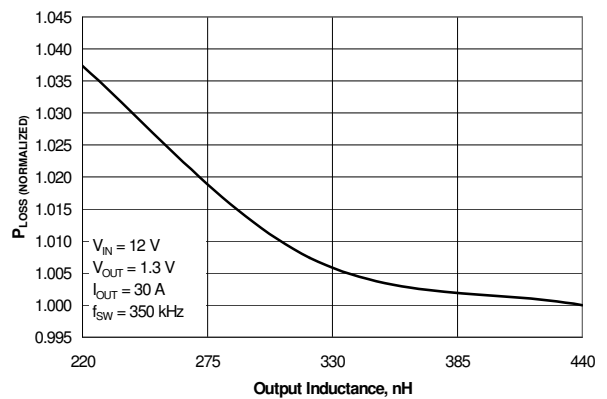

Figure 12. Normalized Power Loss vs. Output Inductance



## Typical Characteristics

$V_{IN} = 12V$ ,  $V_{DRV} = 12V$ ,  $T_A = 25^\circ C$  unless otherwise noted.

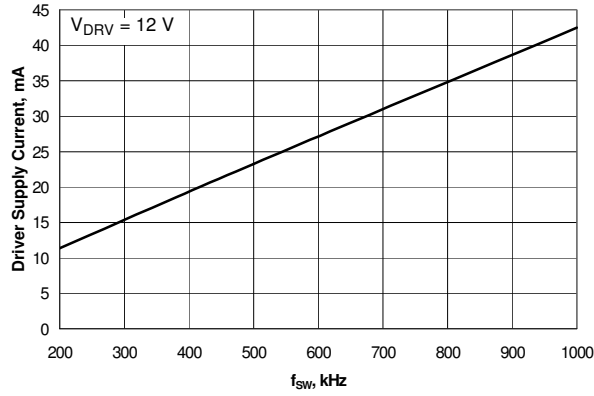

Figure 13. Driver Supply Current vs. Frequency

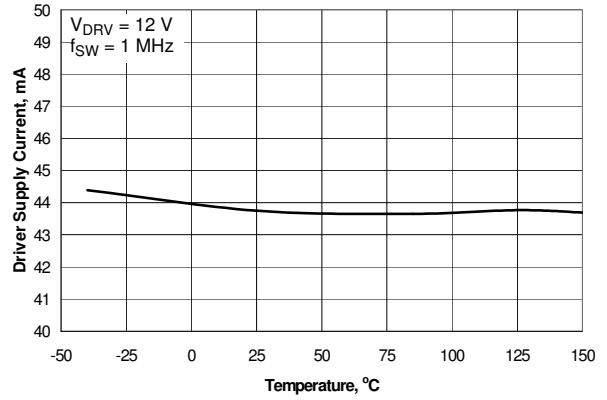

Figure 14. Driver Supply Current vs. Temperature

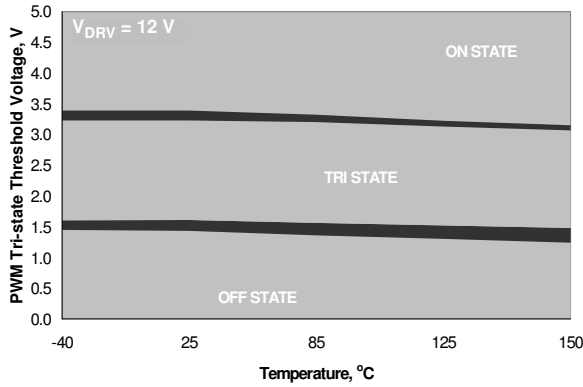

Figure 15. PWM Tri-state Threshold Voltage vs. Temperature

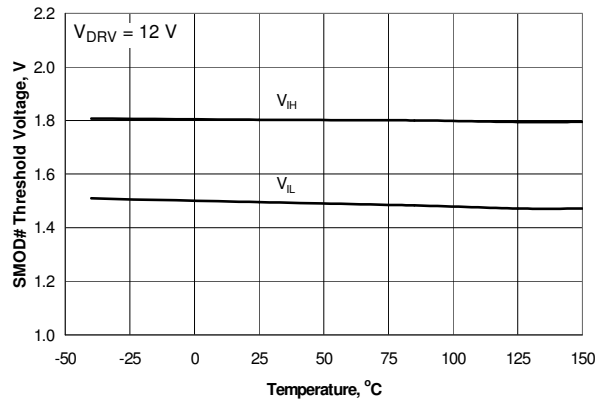

Figure 16. SMOD# Threshold Voltage vs. Temperature

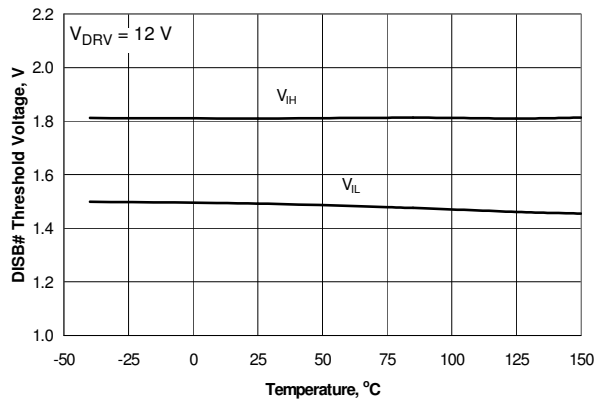

Figure 17. DISB# Threshold Voltage vs. Temperature

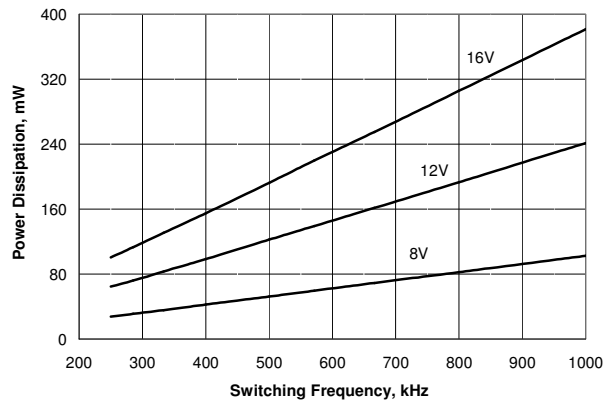

Figure 18. Internal 5 V Regulator Power Dissipation vs. Frequency and VDRV Voltage

## Application Information

### Supply Capacitor Selection

For the supply input (VIN) of the FDMF6704V, a local ceramic bypass capacitor is recommended to reduce the noise and to supply the peak current. Use at least a 4.7μF, X7R or X5R capacitor. Keep this capacitor close to the FDMF6704V VIN and PGND pins.

### Bootstrap Circuit

The bootstrap circuit uses a charge storage capacitor ( $C_{BOOT}$ ), as shown in Figure 19. A bootstrap capacitance of 100nF, X7R capacitor is adequate. A series bootstrap resistor would be needed for specific application in order to improve switching noise immunity.

## Typical Application

Note: For operation with  $V_{IN} < 8V$ , a separate  $> 8V$  supply is required for VDRV.

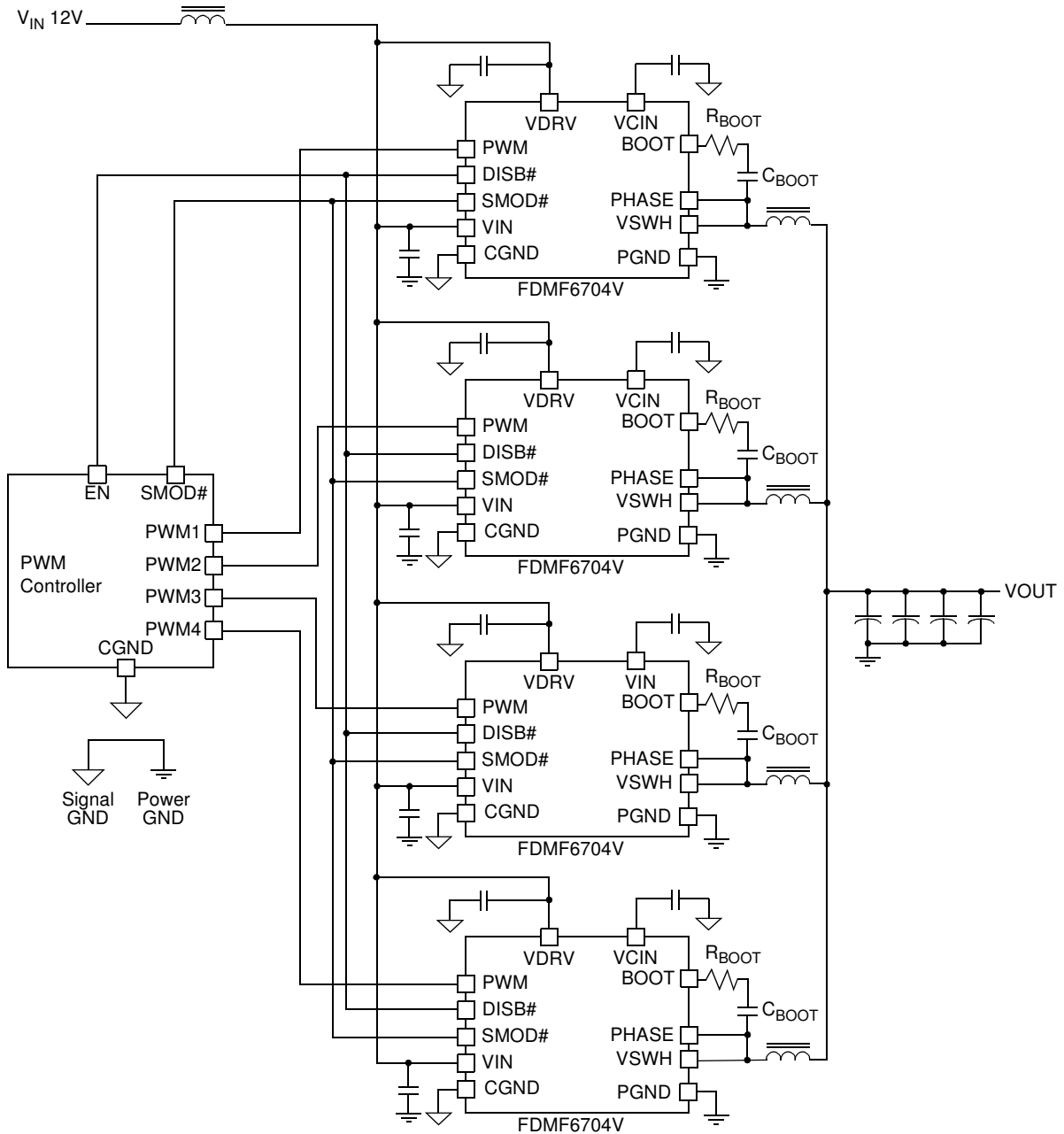

Figure 19. Typical Application

## Power Loss and Efficiency Measurement and Calculation

Refer to Figure 20 for power loss testing method. Power loss calculation are as follows:

- (a)  $P_{IN} = (V_{IN} \times I_{IN}) + (V_{DRV} \times I_{VDRV})$  (W)
- (b)  $P_{SW} = V_{SW} \times I_{OUT}$  (W)
- (c)  $P_{OUT} = V_{OUT} \times I_{OUT}$  (W)
- (d)  $P_{LOSS\_MODULE} = P_{IN} - P_{SW}$  (W)
- (e)  $P_{LOSS\_BOARD} = P_{IN} - P_{OUT}$  (W)
- (f)  $EFF_{MODULE} = 100 \times P_{SW}/P_{IN}$  (%)
- (g)  $EFF_{BOARD} = 100 \times P_{OUT}/P_{IN}$  (%)

## PCB Layout Guideline

Figure 21 shows a proper layout example of FDMF6704V and critical parts. All of high current flow path, such as VIN, VSWH, VOUT and GND copper, should be short and wide for better and stable current flow, heat radiation and system performance.

Following is a guideline which the PCB designer should consider:

- Input ceramic bypass capacitors must be close to VIN and PGND pin of FDMF6704V to help reduce the input current ripple component induced by switching operation.
- The VSWH copper trace serves two purposes. In addition to being the high frequency current path from the DrMOS package to the output inductor, it also serves as heatsink for the lower FET in the DrMOS package. The trace should be short and wide enough to present a low impedance path for the high frequency, high current flow between the DrMOS and inductor in order to minimize losses and temperature rise. Please note that the VSWH node is a high voltage and high frequency switching node with high noise potential. Care should be taken to minimize coupling to adjacent traces. Additionally, since this copper trace also acts as heatsink for the lower FET, tradeoff must be made to use the largest area possible to improve DrMOS cooling while maintaining acceptable noise emission.
- Output inductor location should be as close as possible to the FDMF6704V to minimize lower power loss due to copper trace. Care should be taken so that inductor dissipation does not heat the DrMOS.
- The PowerTrench® 5 MOSFETs used in the output stage are very effective at minimizing ringing. In most cases, no snubber will be required. If a snubber is used, it should be placed near

the FDMF6704V. The resistor and capacitor need to be of proper size for the power dissipation.

- Place ceramic bypass capacitor and BOOT capacitor as close as possible to the VCIN and BOOT pins of the FDMF6704V to ensure clean and stable power. Routing width and length should be considered as well.
- Include a trace from PHASE to VSWH in order to improve noise margin. Keep the trace as short as possible.
- The layout should include the option to insert a small value series boot resistor between boot cap and BOOT pin. The boot loop size, including  $R_{BOOT}$  and  $C_{BOOT}$ , should be as small as possible. The boot resistor is normally not required, but is effective at improving noise operating margin in multi phase designs that may have noise issues due to ground bounce and high negative VSWH ringing. The VIN and PGND pins handle large current transients with frequency components above 100 MHz. If possible, these package pins should be connected directly to the VIN and board GND planes. The use of thermal relief traces in series with these pins is discouraged since this will add inductance to the power path. This added inductance in series with the PGND pin will degrade system noise immunity by increasing negative VSWH ringing.
- CGND pad and PGND pins should be connected by plane GND copper with multiple vias for stable grounding. Poor grounding can create a noise transient offset voltage level between CGND and PGND. This could lead to fault operation of gate driver and MOSFET.
- Ringing at the BOOT pin is most effectively controlled by close placement of the boot capacitor. Do not add an additional BOOT to PGND capacitor. This may lead to excess current flow through the BOOT diode.
- SMOD#, DISB# and PWM pins don't have internal pull up or pull down resistors. They should not be left floating. These pins should not have any noise filter caps.
- Use multiple vias on each copper area to interconnect top, inner and bottom layers to help smooth current flow and heat conduction. Vias should be relatively large and of reasonable inductance. Critical high frequency components such as  $R_{BOOT}$ ,  $C_{BOOT}$ , the RC snubber and bypass caps should be located close to the DrMOS module and on the same side of the PCB as the module. If not feasible, they should be connected from the backside via a network of low inductance vias.

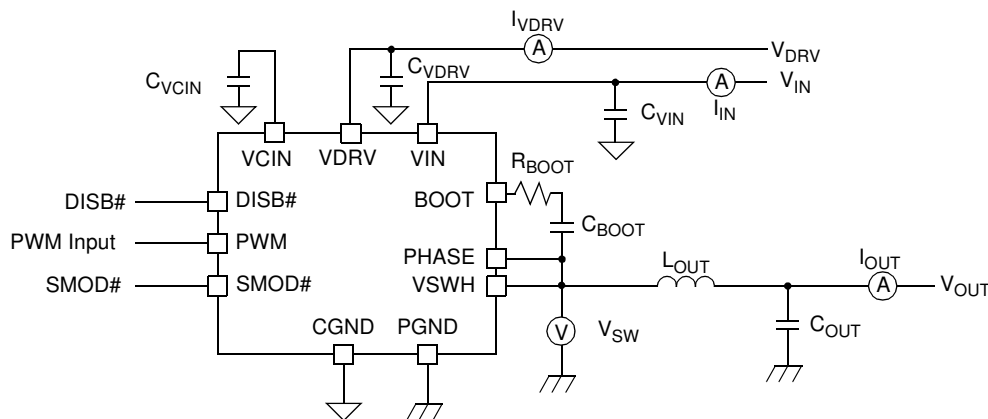

Figure 20. Power Loss Measurement Block Diagram

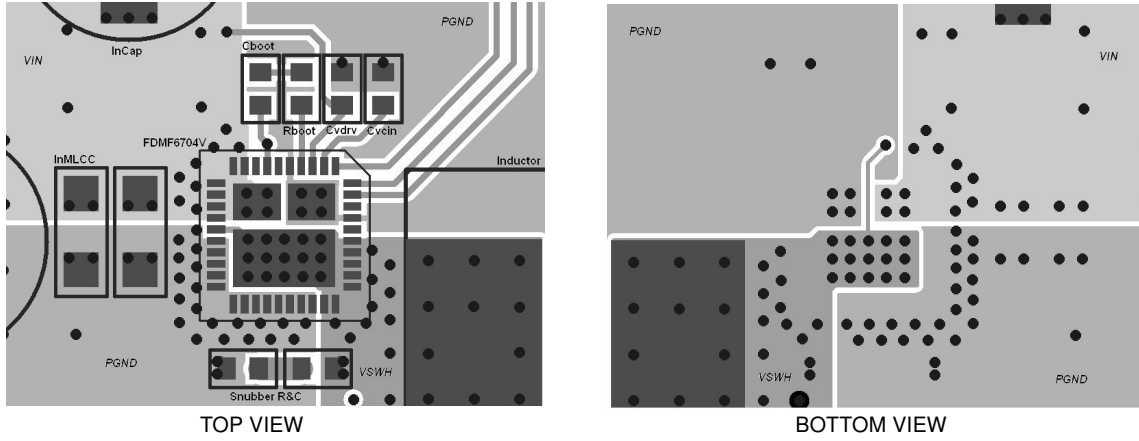
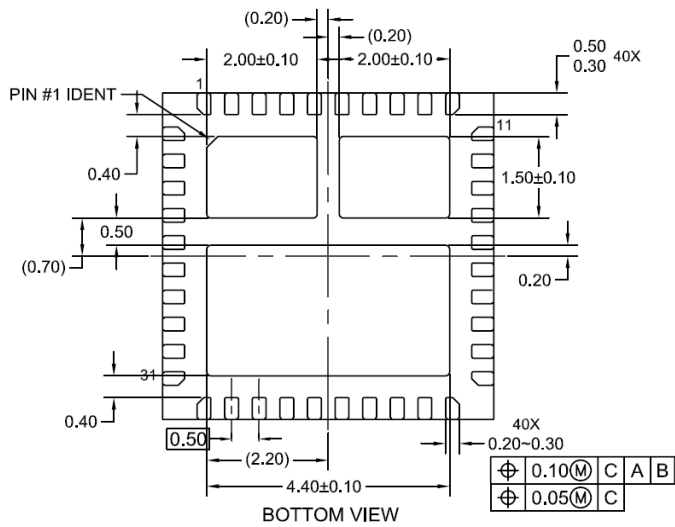
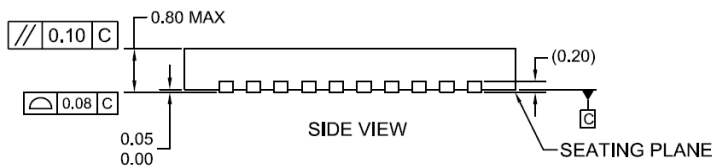
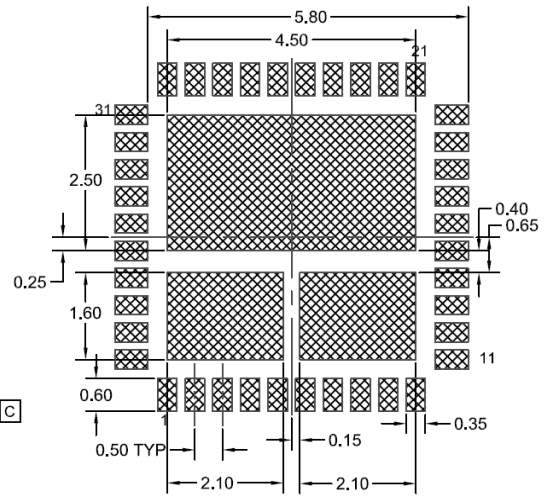
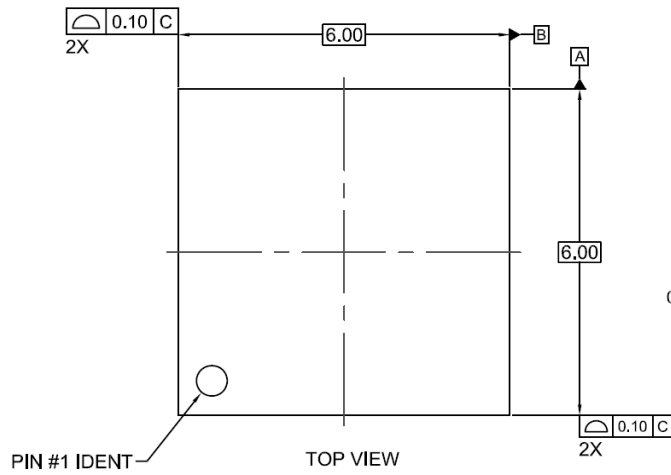

Figure 21. Typical PCB Layout Example

## Dimensional Outline and Pad layout



**NOTES:**

- A. DOES NOT FULLY CONFORM TO JEDEC REGISTRATION, MO-220, DATED MAY/2005.
- B. DIMENSIONS ARE IN MILLIMETERS.
- C. DIMENSIONS AND TOLERANCES PER ASME Y14.5M, 1994
- D. DRAWING FILE NAME: MLP40EREV1



**TRADEMARKS**

The following includes registered and unregistered trademarks and service marks, owned by Fairchild Semiconductor and/or its global subsidiaries, and is not intended to be an exhaustive list of all such trademarks.

- |  |   |  |   |
|--|---|--|---|
| AccuPower™   | FPS™  | PowerTrench®   | The Power Franchise®  |
| Auto-SPM™  | F-PFS™  | PowerXS™   | the power™ franchise  |
| Build it Now™  | FRFET®  | Programmable Active Droop™   | TinyBoost™  |
| CorePLUS™  | Global Power Resource™  | QFET®  | TinyBuck™   |
| CorePOWER™   | Green FPS™  | QS™  | TinyCalc™   |
| CROSSVOLT™   | Green FPS™ e-Series™  | Quiet Series™  | TinyLogic®  |
| CTL™   | Gmax™   | RapidConfigure™  | TINYOPTO™   |
| Current Transfer Logic™  | GTO™  |  ™  | TinyPower™  |
| EcoSPARK®  | IntelliMAX™   | Saving our world, 1mW/W/kW at a time™  | TinyPWM™  |
| EfficientMax™  | ISOPLANAR™  | SmartMax™  | TinyWire™   |
| EZSWITCH™*   | MegaBuck™   | SMART START™   | TriFault Detect™  |
|  ™* | MICROCOUPLER™   | SPM®   | TRUECURRENT™*   |
|  ®  | MicroFET™   | STEALTH™   | µSerDes™  |
| Fairchild®   | MicroPak™   | SuperFET™  |  ™ |
| Fairchild Semiconductor®   | MillerDrive™  | SuperSOT™-3  | UHC®  |
| FACT Quiet Series™   | MotionMax™  | SuperSOT™-6  | Ultra FRFET™  |
| FACT®  | Motion-SPM™   | SuperSOT™-8  | UniFET™   |
| FAST®  | OPTOLOGIC®  | SupreMOS™  | VCX™  |
| FastvCore™   | OPTOPLANAR®   | SyncFET™   | VisualMax™  |
| FETBench™  |  ™ | Sync-Lock™   | XS™   |
| FlashWriter®*  | PDP SPM™  |  ™* |   |
|  | Power-SPM™  |  |   |

\* Trademarks of System General Corporation, used under license by Fairchild Semiconductor.

**DISCLAIMER**

FAIRCHILD SEMICONDUCTOR RESERVES THE RIGHT TO MAKE CHANGES WITHOUT FURTHER NOTICE TO ANY PRODUCTS HEREIN TO IMPROVE RELIABILITY, FUNCTION, OR DESIGN. FAIRCHILD DOES NOT ASSUME ANY LIABILITY ARISING OUT OF THE APPLICATION OR USE OF ANY PRODUCT OR CIRCUIT DESCRIBED HEREIN; NEITHER DOES IT CONVEY ANY LICENSE UNDER ITS PATENT RIGHTS, NOR THE RIGHTS OF OTHERS. THESE SPECIFICATIONS DO NOT EXPAND THE TERMS OF FAIRCHILD'S WORLDWIDE TERMS AND CONDITIONS, SPECIFICALLY THE WARRANTY THEREIN, WHICH COVERS THESE PRODUCTS.

**LIFE SUPPORT POLICY**

FAIRCHILD'S PRODUCTS ARE NOT AUTHORIZED FOR USE AS CRITICAL COMPONENTS IN LIFE SUPPORT DEVICES OR SYSTEMS WITHOUT THE EXPRESS WRITTEN APPROVAL OF FAIRCHILD SEMICONDUCTOR CORPORATION.

As used herein:

1. Life support devices or systems are devices or systems which, (a) are intended for surgical implant into the body or (b) support or sustain life, and (c) whose failure to perform when properly used in accordance with instructions for use provided in the labeling, can be reasonably expected to result in a significant injury of the user.
2. A critical component in any component of a life support, device, or system whose failure to perform can be reasonably expected to cause the failure of the life support device or system, or to affect its safety or effectiveness.

**ANTI-COUNTERFEITING POLICY**

Fairchild Semiconductor Corporation's Anti-Counterfeiting Policy. Fairchild's Anti-Counterfeiting Policy is also stated on our external website, [www.fairchildsemi.com](http://www.fairchildsemi.com), under Sales Support.

Counterfeiting of semiconductor parts is a growing problem in the industry. All manufacturers of semiconductor products are experiencing counterfeiting of their parts. Customers who inadvertently purchase counterfeit parts experience many problems such as loss of brand reputation, substandard performance, failed applications, and increased cost of production and manufacturing delays. Fairchild is taking strong measures to protect ourselves and our customers from the proliferation of counterfeit parts. Fairchild strongly encourages customers to purchase Fairchild parts either directly from Fairchild or from Authorized Fairchild Distributors who are listed by country on our web page cited above. Products customers buy either from Fairchild directly or from Authorized Fairchild Distributors are genuine parts, have full traceability, meet Fairchild's quality standards for handling and storage and provide access to Fairchild's full range of up-to-date technical and product information. Fairchild and our Authorized Distributors will stand behind all warranties and will appropriately address any warranty issues that may arise. Fairchild will not provide any warranty coverage or other assistance for parts bought from Unauthorized Sources. Fairchild is committed to combat this global problem and encourage our customers to do their part in stopping this practice by buying direct or from authorized distributors.

**PRODUCT STATUS DEFINITIONS**

**Definition of Terms**

Datasheet Identification	Product Status	Definition
Advance Information	Formative / In Design	Datasheet contains the design specifications for product development. Specifications may change in any manner without notice.
Preliminary	First Production	Datasheet contains preliminary data; supplementary data will be published at a later date. Fairchild Semiconductor reserves the right to make changes at any time without notice to improve design.
No Identification Needed	Full Production	Datasheet contains final specifications. Fairchild Semiconductor reserves the right to make changes at any time without notice to improve the design.
Obsolete	Not In Production	Datasheet contains specifications on a product that is discontinued by Fairchild Semiconductor. The datasheet is for reference information only.

Rev. I41

ON Semiconductor and  are trademarks of Semiconductor Components Industries, LLC dba ON Semiconductor or its subsidiaries in the United States and/or other countries. ON Semiconductor owns the rights to a number of patents, trademarks, copyrights, trade secrets, and other intellectual property. A listing of ON Semiconductor's product/patent coverage may be accessed at [www.onsemi.com/site/pdf/Patent-Marking.pdf](http://www.onsemi.com/site/pdf/Patent-Marking.pdf). ON Semiconductor reserves the right to make changes without further notice to any products herein. ON Semiconductor makes no warranty, representation or guarantee regarding the suitability of its products for any particular purpose, nor does ON Semiconductor assume any liability arising out of the application or use of any product or circuit, and specifically disclaims any and all liability, including without limitation special, consequential or incidental damages. Buyer is responsible for its products and applications using ON Semiconductor products, including compliance with all laws, regulations and safety requirements or standards, regardless of any support or applications information provided by ON Semiconductor. "Typical" parameters which may be provided in ON Semiconductor data sheets and/or specifications can and do vary in different applications and actual performance may vary over time. All operating parameters, including "Typicals" must be validated for each customer application by customer's technical experts. ON Semiconductor does not convey any license under its patent rights nor the rights of others. ON Semiconductor products are not designed, intended, or authorized for use as a critical component in life support systems or any FDA Class 3 medical devices or medical devices with a same or similar classification in a foreign jurisdiction or any devices intended for implantation in the human body. Should Buyer purchase or use ON Semiconductor products for any such unintended or unauthorized application, Buyer shall indemnify and hold ON Semiconductor and its officers, employees, subsidiaries, affiliates, and distributors harmless against all claims, costs, damages, and expenses, and reasonable attorney fees arising out of, directly or indirectly, any claim of personal injury or death associated with such unintended or unauthorized use, even if such claim alleges that ON Semiconductor was negligent regarding the design or manufacture of the part. ON Semiconductor is an Equal Opportunity/Affirmative Action Employer. This literature is subject to all applicable copyright laws and is not for resale in any manner.

## PUBLICATION ORDERING INFORMATION

### LITERATURE FULFILLMENT:

Literature Distribution Center for ON Semiconductor  
19521 E. 32nd Pkwy, Aurora, Colorado 80011 USA  
**Phone:** 303-675-2175 or 800-344-3860 Toll Free USA/Canada  
**Fax:** 303-675-2176 or 800-344-3867 Toll Free USA/Canada  
**Email:** [orderlit@onsemi.com](mailto:orderlit@onsemi.com)

**N. American Technical Support:** 800-282-9855 Toll Free  
USA/Canada  
**Europe, Middle East and Africa Technical Support:**  
Phone: 421 33 790 2910  
**Japan Customer Focus Center**  
Phone: 81-3-5817-1050

**ON Semiconductor Website:** [www.onsemi.com](http://www.onsemi.com)  
**Order Literature:** <http://www.onsemi.com/orderlit>  
For additional information, please contact your local  
Sales Representative

# Mouser Electronics

Authorized Distributor

Click to View Pricing, Inventory, Delivery & Lifecycle Information:

[ON Semiconductor:](#)

[FDMF6704V](#)



Компания «Океан Электроники» предлагает заключение долгосрочных отношений при поставках импортных электронных компонентов на взаимовыгодных условиях!

Наши преимущества:

- Поставка оригинальных импортных электронных компонентов напрямую с производств Америки, Европы и Азии, а так же с крупнейших складов мира;
- Широкая линейка поставок активных и пассивных импортных электронных компонентов (более 30 млн. наименований);
- Поставка сложных, дефицитных, либо снятых с производства позиций;
- Оперативные сроки поставки под заказ (от 5 рабочих дней);
- Экспресс доставка в любую точку России;
- Помощь Конструкторского Отдела и консультации квалифицированных инженеров;
- Техническая поддержка проекта, помощь в подборе аналогов, поставка прототипов;
- Поставка электронных компонентов под контролем ВП;
- Система менеджмента качества сертифицирована по Международному стандарту ISO 9001;
- При необходимости вся продукция военного и аэрокосмического назначения проходит испытания и сертификацию в лаборатории (по согласованию с заказчиком);
- Поставка специализированных компонентов военного и аэрокосмического уровня качества (Xilinx, Altera, Analog Devices, Intersil, Interpoint, Microsemi, Actel, Aeroflex, Peregrine, VPT, Syfer, Eurofarad, Texas Instruments, MS Kennedy, Miteq, Cobham, E2V, MA-COM, Hittite, Mini-Circuits, General Dynamics и др.);

Компания «Океан Электроники» является официальным дистрибьютором и эксклюзивным представителем в России одного из крупнейших производителей разъемов военного и аэрокосмического назначения «JONHON», а так же официальным дистрибьютором и эксклюзивным представителем в России производителя высокотехнологичных и надежных решений для передачи СВЧ сигналов «FORSTAR».



## JONHON

«JONHON» (основан в 1970 г.)

Разъемы специального, военного и аэрокосмического назначения:

(Применяются в военной, авиационной, аэрокосмической, морской, железнодорожной, горно- и нефтедобывающей отраслях промышленности)

«FORSTAR» (основан в 1998 г.)

ВЧ соединители, коаксиальные кабели, кабельные сборки и микроволновые компоненты:

(Применяются в телекоммуникациях гражданского и специального назначения, в средствах связи, РЛС, а так же военной, авиационной и аэрокосмической отраслях промышленности).



Телефон: 8 (812) 309-75-97 (многоканальный)

Факс: 8 (812) 320-03-32

Электронная почта: [ocean@oceanchips.ru](mailto:ocean@oceanchips.ru)

Web: <http://oceanchips.ru/>

Адрес: 198099, г. Санкт-Петербург, ул. Калинина, д. 2, корп. 4, лит. А