

FEATURES

High Off Isolation –80 dB at 30 MHz
–3 dB Signal Bandwidth 250 MHz
+1.8 V to +5.5 V Single Supply
Low On-Resistance (15 Ω Typically)
Low On-Resistance Flatness
Fast Switching Times
t_{ON} Typically 8 ns
t_{OFF} Typically 3 ns
Typical Power Consumption < 0.01 μ W
TTL/CMOS Compatible

APPLICATIONS

Audio and Video Switching
RF Switching
Networking Applications
Battery Powered Systems
Communication Systems
Relay Replacement
Sample-and-Hold Systems

GENERAL DESCRIPTION

The ADG752 is a low voltage SPDT (single pole, double throw) switch. It is constructed using switches in a T-switch configuration, which results in excellent Off Isolation while maintaining good frequency response in the ON condition.

High off isolation and wide signal bandwidth make this part suitable for switching RF and video signals. Low power consumption and operating supply range of +1.8 V to +5.5 V make it ideal for battery powered, portable instruments.

The ADG752 is designed on a submicron process that provides low power dissipation yet gives high switching speed and low on resistance. This part is a fully bidirectional switch and can handle signals up to and including the supply rails. Break-before-make switching action ensures the input signals are protected against momentary shorting when switching between channels.

The ADG752 is available in 6-lead SOT-23 and 8-lead μ SOIC packages.

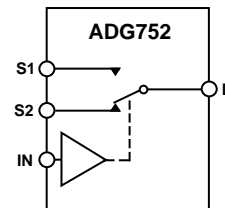
FUNCTIONAL BLOCK DIAGRAM

SWITCH SHOWN FOR A LOGIC "1" INPUT

PRODUCT HIGHLIGHTS

1. High Off Isolation –80 dB at 30 MHz.
2. –3 dB Signal Bandwidth 250 MHz.
3. Low On Resistance (15 Ω).
4. Low Power Consumption, typically <0.01 μ W.
5. Break-Before-Make Switching Action.
6. Tiny 6-lead SOT-23 and 8-lead μ SOIC packages.

REV. 0

Information furnished by Analog Devices is believed to be accurate and reliable. However, no responsibility is assumed by Analog Devices for its use, nor for any infringements of patents or other rights of third parties which may result from its use. No license is granted by implication or otherwise under any patent or patent rights of Analog Devices.

ADG752—SPECIFICATIONS ($V_{DD} = +5\text{ V} \pm 10\%$, $GND = 0\text{ V}$, unless otherwise noted.)

Parameter	B Version		Units	Test Conditions/Comments
	+25°C	-40°C to +85°C		
ANALOG SWITCH				
Analogue Signal Range		0 V to V_{DD}	V	
On-Resistance (R_{ON})	15		Ω typ	$V_S = 0\text{ V}$ to V_{DD} , $I_{DS} = 10\text{ mA}$; Test Circuit 1
	18		Ω max	
On-Resistance Match Between Channels (ΔR_{ON})	0.1	20	Ω typ	$V_S = 0\text{ V}$ to V_{DD} , $I_{DS} = 10\text{ mA}$
	0.6	0.6	Ω max	
On-Resistance Flatness ($R_{FLAT(ON)}$)	2		Ω typ	$V_S = 0\text{ V}$ to 2.5 V, $I_{DS} = 10\text{ mA}$
		3	Ω max	$V_{DD} = +4.5\text{ V}$
LEAKAGE CURRENTS				
Source OFF Leakage I_S (OFF)	± 0.01		nA typ	$V_D = 4.5\text{ V}/1\text{ V}$, $V_S = 1\text{ V}/4.5\text{ V}$; Test Circuit 2
	± 0.25	± 3.0	nA max	
Channel ON Leakage I_D , I_S (ON)	± 0.01		nA typ	$V_D = V_S = 1\text{ V}$, or 4.5 V; Test Circuit 3
	± 0.25	± 3.0	nA max	
DIGITAL INPUTS				
Input High Voltage, V_{INH}		2.4	V min	
Input Low Voltage, V_{INL}		0.8	V max	
Input Current				
I_{INL} or I_{INH}	0.001		μA typ	$V_{IN} = V_{INL}$ or V_{INH}
		± 0.5	μA max	
C_{IN} , Digital Input Capacitance	2		pF typ	
DYNAMIC CHARACTERISTICS¹				
t_{ON}	8		ns typ	$R_L = 300\ \Omega$, $C_L = 35\text{ pF}$; $V_S = 3\text{ V}$, Test Circuit 4
		13	ns max	
t_{OFF}	3		ns typ	$R_L = 300\ \Omega$, $C_L = 35\text{ pF}$; $V_S = 3\text{ V}$, Test Circuit 4
		5	ns max	
Break-Before-Make Time Delay	6		ns typ	$R_L = 300\ \Omega$, $C_L = 35\text{ pF}$; $V_S = 3\text{ V}$, Test Circuit 5
		1	ns min	
Off Isolation	-80		dB typ	$R_L = 50\ \Omega$, $C_L = 5\text{ pF}$, $f = 30\text{ MHz}$; Test Circuit 6
Crosstalk	-80		dB typ	$R_L = 50\ \Omega$, $C_L = 5\text{ pF}$, $f = 30\text{ MHz}$; Test Circuit 7
-3 dB Bandwidth	250		MHz typ	$R_L = 50\ \Omega$, $C_L = 5\text{ pF}$, Test Circuit 8
C_S (OFF)	4		pF typ	
C_D , C_S (ON)	15		pF typ	
POWER REQUIREMENTS				
I_{DD}	0.001		μA typ	$V_{DD} = +5.5\text{ V}$ Digital Inputs = 0 V or +5.5 V
	0.1	0.5	μA max	

NOTES

¹Guaranteed by design, not subject to production test.

Specifications subject to change without notice.

SPECIFICATIONS (V_{DD} = +3 V ± 10%, GND = 0 V, unless otherwise noted.)

ADG752

Parameter	B Version		Units	Test Conditions/Comments
	+25°C	-40°C to +85°C		
ANALOG SWITCH				
Analog Signal Range		0 V to V _{DD}	V	
On-Resistance (R _{ON})	35	50	Ω typ Ω max	V _S = 0 V to V _{DD} , I _{DS} = 10 mA; Test Circuit 1
On-Resistance Match Between Channels (ΔR _{ON})	0.2 2.5	2.5	Ω typ Ω max	V _S = 0 V to V _{DD} , I _{DS} = 10 mA
LEAKAGE CURRENTS				
Source OFF Leakage I _S (OFF)	±0.01 ±0.25	±3.0	nA typ nA max	V _{DD} = +3.3 V V _S = 3 V/1 V, V _D = 1 V/3 V; Test Circuit 2
Channel ON Leakage I _D , I _S (ON)	±0.01 ±0.25	±3.0	nA typ nA max	V _S = V _D = 1 V or 3 V; Test Circuit 3
DIGITAL INPUTS				
Input High Voltage, V _{INH}		2.0	V min	
Input Low Voltage, V _{INL}		0.4	V max	
Input Current I _{INL} or I _{INH}	0.001	±0.5	μA typ μA max	V _{IN} = V _{INL} or V _{INH}
C _{IN} , Digital Input Capacitance	2		pF typ	
DYNAMIC CHARACTERISTICS¹				
t _{ON}	10	18	ns typ ns max	R _L = 300 Ω, C _L = 35 pF; V _S = 2 V, Test Circuit 4
t _{OFF}	4	8	ns typ ns max	R _L = 300 Ω, C _L = 35 pF; V _S = 2 V, Test Circuit 4
Break-Before-Make Time Delay	6	1	ns typ ns min	R _L = 300 Ω, C _L = 35 pF; V _S = 2 V, Test Circuit 5
Off Isolation	-80		dB typ	R _L = 50 Ω, C _L = 5 pF, f = 30 MHz; Test Circuit 6
Crosstalk	-80		dB typ	R _L = 50 Ω, C _L = 5 pF, f = 30 MHz; Test Circuit 7
-3 dB Bandwidth	250		MHz typ	R _L = 50 Ω, C _L = 5 pF, Test Circuit 8
C _S (OFF)	4		pF typ	
C _D , C _S (ON)	15		pF typ	
POWER REQUIREMENTS				
I _{DD}	0.001 0.1	0.5	μA typ μA max	V _{DD} = +3.3 V Digital Inputs = 0 V or +3.3 V

NOTES

¹Guaranteed by design, not subject to production test.

Specifications subject to change without notice.

ADG752

ABSOLUTE MAXIMUM RATINGS¹

(T_A = +25°C unless otherwise noted)

V _{DD} to GND	−0.3 V to +6 V
Analog, Digital Inputs ²	−0.3 V to V _{DD} + 0.3 V or 30 mA, Whichever Occurs First
Peak Current, S or D	100 mA (Pulsed at 1 ms, 10% Duty Cycle Max)
Continuous Current, S or D	30 mA
Operating Temperature Range	
Industrial (B Version)	−40°C to +85°C
Storage Temperature Range	−65°C to +150°C
Power Dissipation	(T _J Max − T _A)/θ _{JA}
Junction Temperature (T _J Max)	+150°C
μSOIC Package	
θ _{JA} Thermal Impedance	206°C/W
θ _{JC} Thermal Impedance	44°C/W
SOT-23 Package	
θ _{JA} Thermal Impedance	229.6°C/W
θ _{JC} Thermal Impedance	91.99°C/W
Lead Temperature, Soldering	
Vapor Phase (60 sec)	+215°C
Infrared (15 sec)	+220°C

NOTES

¹Stresses above those listed under Absolute Maximum Ratings may cause permanent damage to the device. This is a stress rating only; functional operation of the device at these or any other conditions above those listed in the operational sections of this specification is not implied. Exposure to absolute maximum rating conditions for extended periods may affect device reliability. Only one absolute maximum rating may be applied at any one time.

²Overtypes at IN, S or D will be clamped by internal diodes. Current should be limited to the maximum ratings given.

PIN CONFIGURATIONS

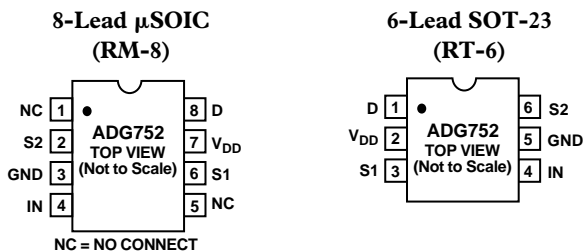

Table I. Truth Table

ADG752 IN	Switch S1	Switch S2
0	ON	OFF
1	OFF	ON

TERMINOLOGY

V _{DD}	Most positive power supply potential.
GND	Ground (0 V) reference.
S	Source terminal. May be an input or output.
D	Drain terminal. May be an input or output.
IN	Logic control input.
R _{ON}	Ohmic resistance between D and S.
ΔR _{ON}	On resistance match between channels, i.e., R _{ONmax} − R _{ONmin} .
R _{FLAT(ON)}	Flatness is defined as the difference between the maximum and minimum value of on resistance as measured over the specified analog signal range.
I _S (OFF)	Source leakage current with the switch “OFF.”
I _D , I _S (ON)	Channel leakage current with the switch “ON.”
V _D (V _S)	Analog voltage on terminals D and S.
C _S (OFF)	“OFF” switch source capacitance.
C _D , C _S (ON)	“ON” switch capacitance.
t _{ON}	Delay between applying the digital control input and the output switching on. See Test Circuit 4.
t _{OFF}	Delay between applying the digital control input and the output switching off.
t _D	“OFF” time or “ON” time measured between the 90% points of both switches, when switching from one address state to another.
Off Isolation	A measure of unwanted signal coupling through an “OFF” switch.
Crosstalk	A measure of unwanted signal that is coupled through from one channel to another as a result of parasitic capacitance.
Bandwidth	The frequency at which the output is attenuated by −3 dBs.
On Response	The frequency response of the “ON” switch.
Insertion Loss	Loss due to the ON resistance of the switch.
V _{INL}	Maximum input voltage for Logic “0.”
V _{INH}	Minimum input voltage for Logic “1.”
I _{INL} (I _{INH})	Input current of the digital input.
I _{DD}	Positive supply current.

ORDERING GUIDE

Model	Temperature Range	Brand*	Package Descriptions	Package Options
ADG752BRM	−40°C to +85°C	SEB	μSOIC	RM-8
ADG752BRT	−40°C to +85°C	SEB	SOT-23	RT-6

*Brand on these packages is limited to three characters due to space constraints.

CAUTION

ESD (electrostatic discharge) sensitive device. Electrostatic charges as high as 4000 V readily accumulate on the human body and test equipment and can discharge without detection. Although the ADG752 features proprietary ESD protection circuitry, permanent damage may occur on devices subjected to high energy electrostatic discharges. Therefore, proper ESD precautions are recommended to avoid performance degradation or loss of functionality.



Typical Performance Characteristics—ADG752

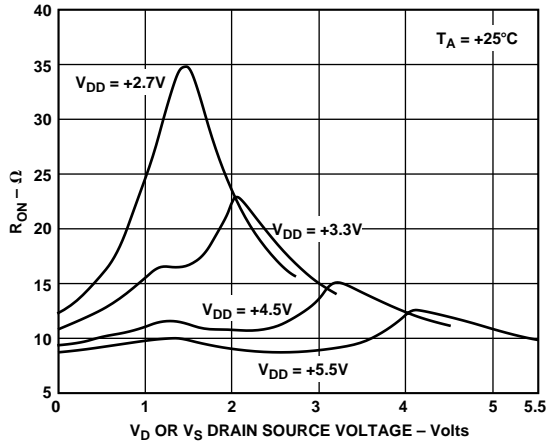

Figure 1. On Resistance as a Function of V_D (V_S) Single Supplies

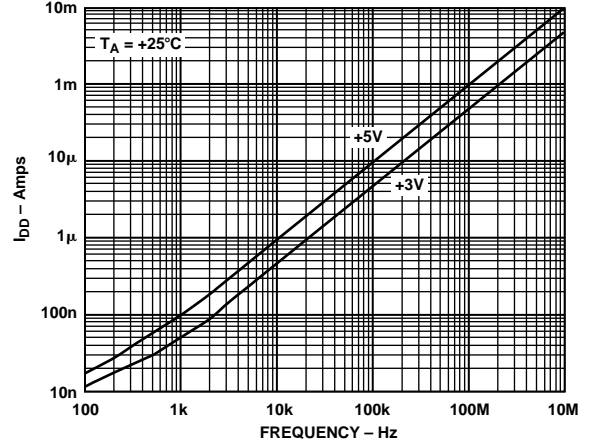

Figure 4. Supply Current vs. Input Switching Frequency

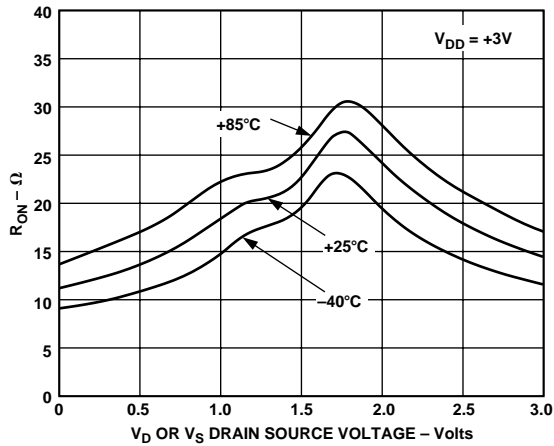

Figure 2. On Resistance as a Function of V_D (V_S) for Different Temperatures $V_{DD} = 3\text{V}$

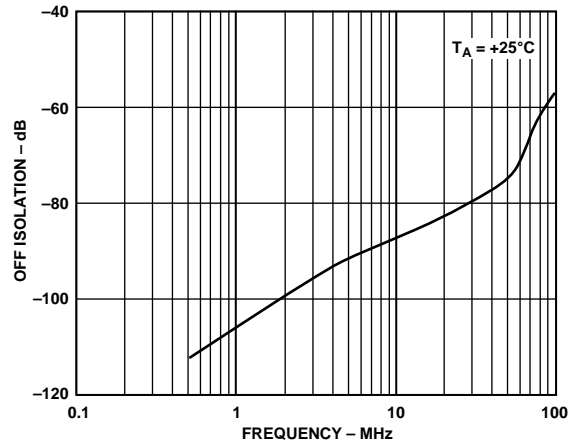

Figure 5. Off Isolation vs. Frequency

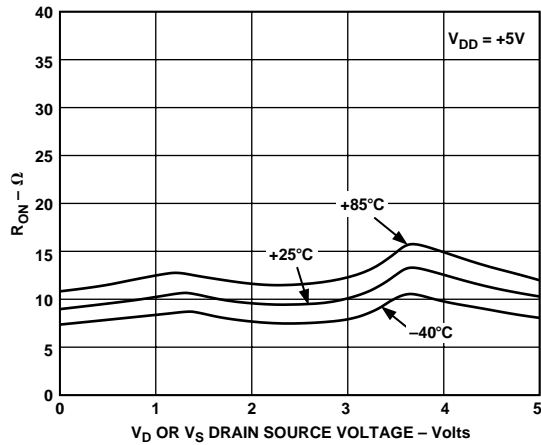

Figure 3. On Resistance as a Function of V_D (V_S) for Different Temperatures $V_{DD} = 5\text{V}$

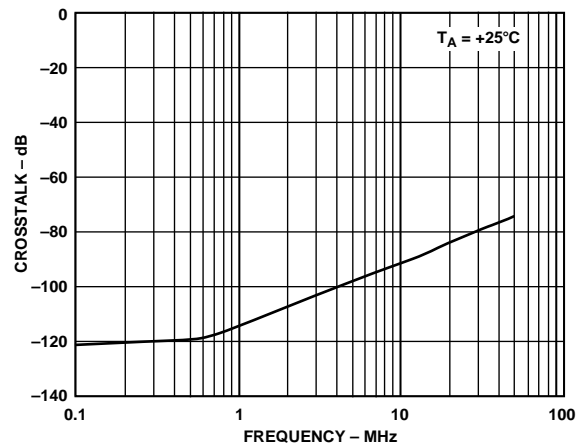

Figure 6. Crosstalk vs. Frequency

ADG752

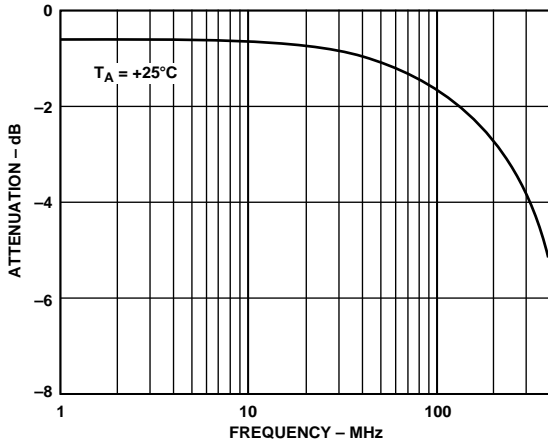

Figure 7. On Response vs. Frequency

GENERAL DESCRIPTION

The ADG752 is an SPDT switch constructed using switches in a T configuration to obtain high “OFF” isolation while maintaining good frequency response in the “ON” condition.

Figure 8 shows the T-switch configuration. While the switch is in the OFF state, the shunt switch is closed and the two series switches are open. The closed shunt switch provides a signal path to ground for any of the unwanted signals that find their way through the off capacitances of the series’ MOS devices. This results in more improved isolation between the input and output than with an ordinary series switch. When the switch is in the ON condition, the shunt switch is open and the signal path is through the two series switches which are now closed.

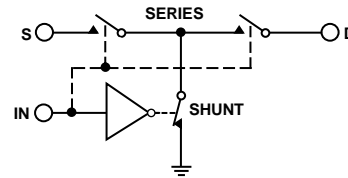

Figure 8. Basic T-Switch Configuration

LAYOUT CONSIDERATIONS

Where accurate high frequency operation is important, careful consideration should be given to the printed circuit board layout and to grounding. Wire wrap boards, prototype boards and sockets are not recommended because of their high parasitic inductance and capacitance. The part should be soldered directly to a printed circuit board. A ground plane should cover all unused areas of the component side of the board to provide a low impedance path to ground. Removing the ground planes from the area around the part reduces stray capacitance.

Good decoupling is important in achieving optimum performance. V_{DD} should be decoupled with a 0.1 μF surface mount capacitor to ground mounted as close as possible to the device itself.

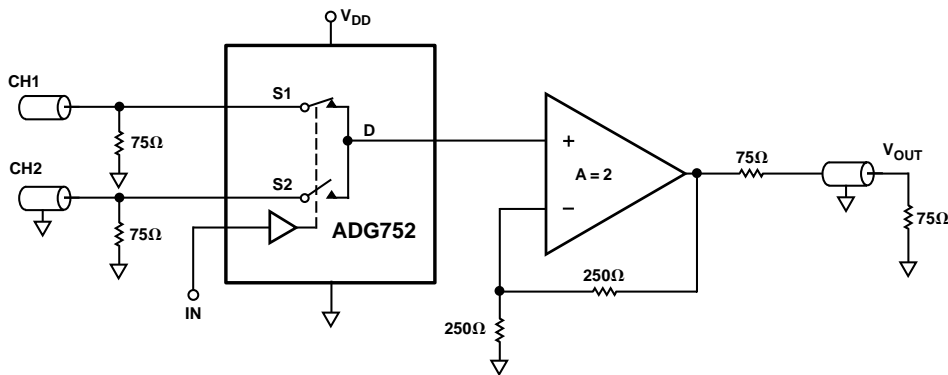
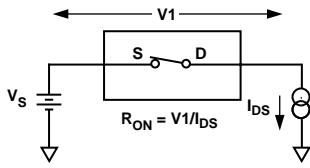
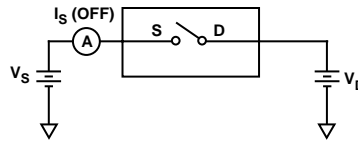

Figure 9. Multiplexing Between Two Video Signals

Test Circuits



Test Circuit 1. On Resistance



Test Circuit 2. Off Leakage

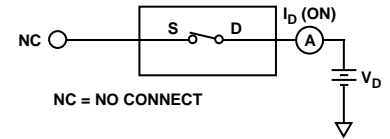

Test Circuit 3. On Leakage

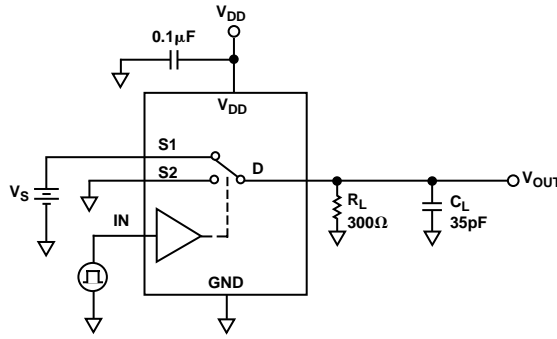

Test Circuit 4. Switching Times

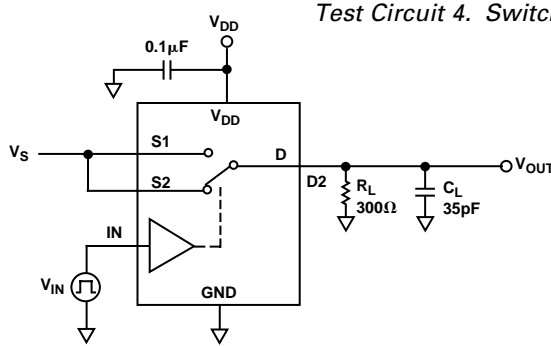
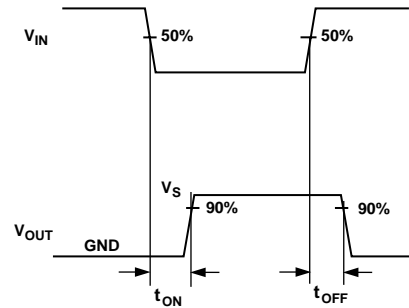

Test Circuit 5. Break-Before-Make Time Delay, t_D

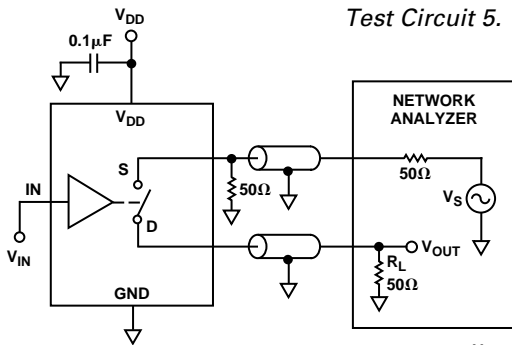
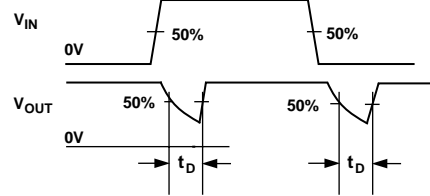

$$\text{OFF ISOLATION} = 20 \text{ LOG } \frac{V_{\text{OUT}}}{V_S}$$

Test Circuit 6. Off Isolation

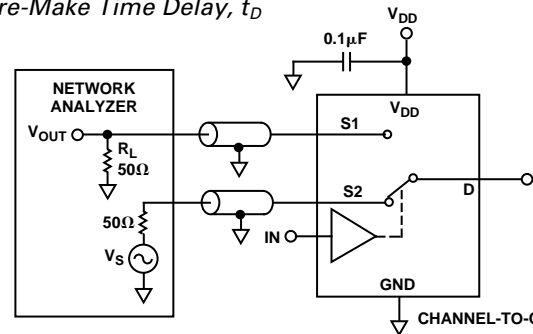

$$\text{CROSSTALK} = 20 \text{ LOG } \frac{V_{\text{OUT}}}{V_S}$$

Test Circuit 7. Channel-to-Channel Crosstalk

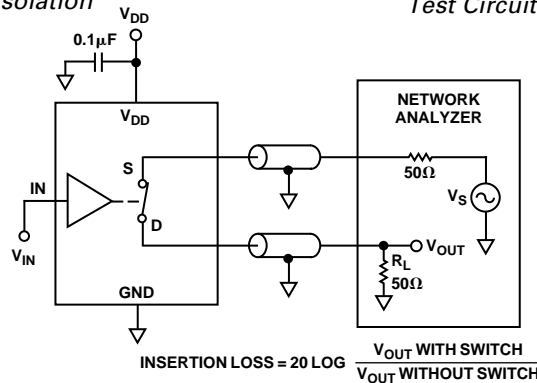

$$\text{INSERTION LOSS} = 20 \text{ LOG } \frac{V_{\text{OUT WITH SWITCH}}}{V_{\text{OUT WITHOUT SWITCH}}}$$

Test Circuit 8. Bandwidth

OUTLINE DIMENSIONS

Dimensions shown in inches and (mm).

8-Lead μ SOIC
(RM-8)

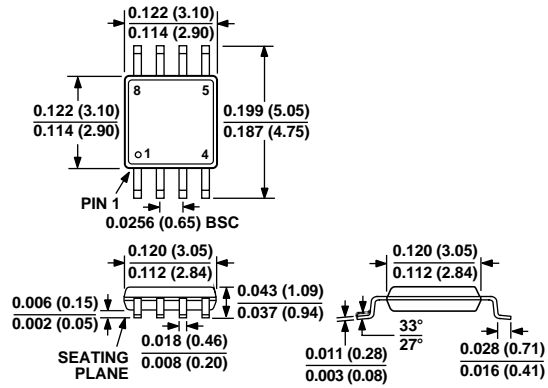

6-Lead SOT-23
(RT-6)

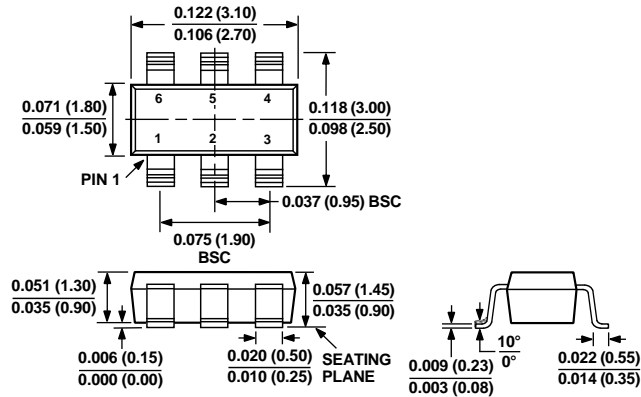

Компания «Океан Электроники» предлагает заключение долгосрочных отношений при поставках импортных электронных компонентов на взаимовыгодных условиях!

Наши преимущества:

- Поставка оригинальных импортных электронных компонентов напрямую с производств Америки, Европы и Азии, а так же с крупнейших складов мира;
- Широкая линейка поставок активных и пассивных импортных электронных компонентов (более 30 млн. наименований);
- Поставка сложных, дефицитных, либо снятых с производства позиций;
- Оперативные сроки поставки под заказ (от 5 рабочих дней);
- Экспресс доставка в любую точку России;
- Помощь Конструкторского Отдела и консультации квалифицированных инженеров;
- Техническая поддержка проекта, помощь в подборе аналогов, поставка прототипов;
- Поставка электронных компонентов под контролем ВП;
- Система менеджмента качества сертифицирована по Международному стандарту ISO 9001;
- При необходимости вся продукция военного и аэрокосмического назначения проходит испытания и сертификацию в лаборатории (по согласованию с заказчиком);
- Поставка специализированных компонентов военного и аэрокосмического уровня качества (Xilinx, Altera, Analog Devices, Intersil, Interpoint, Microsemi, Actel, Aeroflex, Peregrine, VPT, Syfer, Eurofarad, Texas Instruments, MS Kennedy, Miteq, Cobham, E2V, MA-COM, Hittite, Mini-Circuits, General Dynamics и др.);

Компания «Океан Электроники» является официальным дистрибьютором и эксклюзивным представителем в России одного из крупнейших производителей разъемов военного и аэрокосмического назначения «JONHON», а так же официальным дистрибьютором и эксклюзивным представителем в России производителя высокотехнологичных и надежных решений для передачи СВЧ сигналов «FORSTAR».



JONHON

«JONHON» (основан в 1970 г.)

Разъемы специального, военного и аэрокосмического назначения:

(Применяются в военной, авиационной, аэрокосмической, морской, железнодорожной, горно- и нефтедобывающей отраслях промышленности)

«FORSTAR» (основан в 1998 г.)

ВЧ соединители, коаксиальные кабели,
кабельные сборки и микроволновые компоненты:

(Применяются в телекоммуникациях гражданского и специального назначения, в средствах связи, РЛС, а так же военной, авиационной и аэрокосмической отраслях промышленности).



Телефон: 8 (812) 309-75-97 (многоканальный)

Факс: 8 (812) 320-03-32

Электронная почта: ocean@oceanchips.ru

Web: <http://oceanchips.ru/>

Адрес: 198099, г. Санкт-Петербург, ул. Калинина, д. 2, корп. 4, лит. А