

### Circuits from the Lab™ Reference Circuits

Circuits from the Lab™ reference circuits are engineered and tested for quick and easy system integration to help solve today's analog, mixed-signal, and RF design challenges. For more information and/or support, visit [www.analog.com/CN0209](http://www.analog.com/CN0209).

#### Devices Connected/Referenced

ADP1720	High Voltage, Low Dropout Linear Regulator	ADG442	LC <sup>2</sup> MOS Quad SPST Switches
AD8275	G = 0.2, Level Translation ADC Driver	AD8676	Dual, Rail-to-Rail Output Op Amp
REF194	Precision, 4.5 V Voltage Reference	AD7193	24-Bit $\Sigma$ - $\Delta$ ADC
AD8617	Low Noise, Rail-to-Rail Input/Output Amp	ADuM1400	Quad-Channel Digital Isolator
ADT7310	16-Bit Digital Temperature Sensor	ADuM1401	Quad-Channel Digital Isolator
ADG1414	Serially-Controlled Octal SPST Switches		

## Fully Programmable Universal Analog Front End for Process Control Applications

### EVALUATION AND DESIGN SUPPORT

#### Circuit Evaluation Boards

[CN-0209 Circuit Evaluation Board \(EVAL-CN0209-SDPZ\)](#)  
[System Demonstration Platform \(EVAL-SDP-CB1Z\)](#)

#### Design and Integration Files

[Schematics](#), [Layout Files](#), [Bill of Materials](#)

### CIRCUIT FUNCTION AND BENEFITS

The circuit shown in Figure 1 provides a fully programmable universal analog front end (AFE) for process control applications. The following inputs are supported: 2-, 3-, and 4-wire RTD configurations, thermocouple inputs with cold junction compensation, unipolar and bipolar input voltages, and 4 mA-to-20 mA inputs.

Today, many analog input modules use wire links (jumpers) to configure the customer input requirements. This requires time, knowledge, and manual intervention to configure and reconfigure the input. This circuit provides a software controllable switch to configure the modes along with a constant current source to excite the RTD. The circuit is also reconfigurable to set common-mode voltages for the thermocouple configuration. A differential amplifier is used to condition the analog input voltage range to the  $\Sigma$ - $\Delta$  ADC. The circuit provides industry-leading performance and cost.

Because of the voltage gain provided by the [AD8676](#) and [AD8275](#), the design is particularly suitable for small signal inputs, all types of RTDs, or thermocouples.

The [AD7193](#) is a 24-bit  $\Sigma$ - $\Delta$  ADC that can be configured to have four differential inputs or eight pseudo differential inputs. The [ADuM1400](#) and [ADuM1401](#) provide all the necessary signal isolation between the microcontroller and the ADC.

The circuit also includes standard external protection and is compliant with the IEC 61000 specifications.

### CIRCUIT DESCRIPTION

This circuit provides a fully programmable universal analog front end (AFE) for process control applications supporting 2-, 3-, and 4-wire RTD configurations, thermocouple inputs with cold junction compensation, unipolar and bipolar input voltages, and 4 mA-to-20 mA inputs as shown in the configuration diagram of Figure 2.

The [ADG1414](#), a serially controlled octal SPST switch, is used to configure the selected measurement mode.

#### Voltage Measurement

This circuit supports the measurement of unipolar and bipolar signal ranges up to  $\pm 10$  V. The input signal goes through a signal conditioning stage before conversion by the [AD7193](#) ADC. The [AD8676](#) amplifier buffers the inputs before the gain stage. The [AD8275](#) is used to level shift the input signal and provides gain so that it matches the input range of the [AD7193](#). The [AD8275](#) output is biased with a common-mode voltage connected to its REF pin. This voltage is generated by the [REF194](#) precision 4.5 V reference.

#### RTD Measurement

As shown in the connection table, this circuit supports 2-, 3-, and 4-wire RTD configurations. In this case, the transducer is a 1000  $\Omega$  platinum (Pt) RTD (resistive temperature device). The most accurate arrangement is a 4-lead RTD configuration. In the application shown, an external 200  $\mu$ A current source provides the excitation current for the RTD, and the [AD7193](#) is operated at gain of 16 to maximize the dynamic range in the circuit. The [AD8617](#) amplifier is configured as a current source when the RTD measurement mode is selected. It is reconfigured in closed-loop to set the common-mode voltage when the thermocouple measurement is selected. The [AD8617](#) is a dual low noise amplifier so that it can drive both input channels

#### Rev. 0

Circuits from the Lab™ circuits from Analog Devices have been designed and built by Analog Devices engineers. Standard engineering practices have been employed in the design and construction of each circuit, and their function and performance have been tested and verified in a lab environment at room temperature. However, you are solely responsible for testing the circuit and determining its suitability and applicability for your use and application. Accordingly, in no event shall Analog Devices be liable for direct, indirect, special, incidental, consequential or punitive damages due to any cause whatsoever connected to the use of any Circuits from the Lab circuits. (Continued on last page)

09839-001

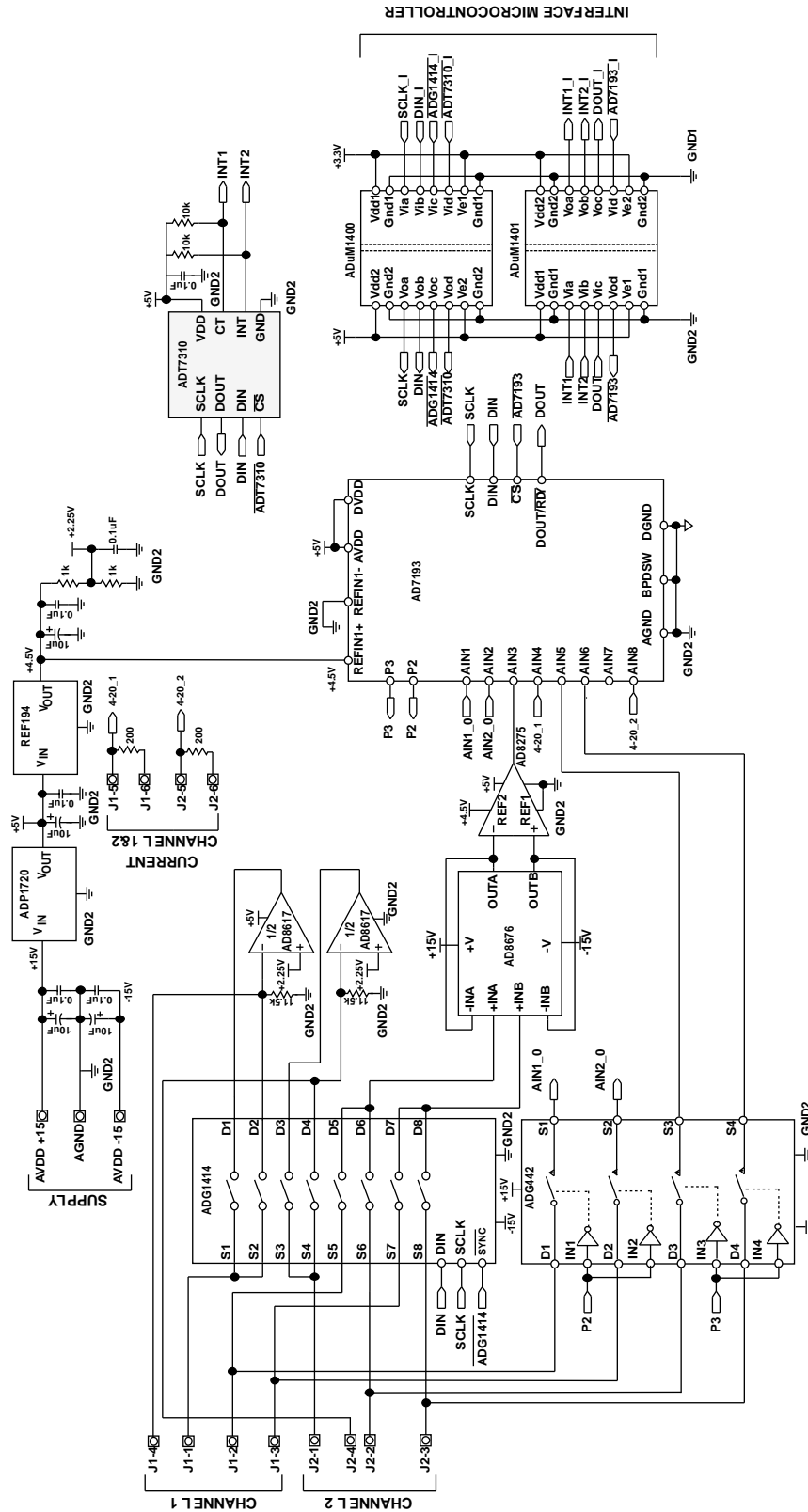
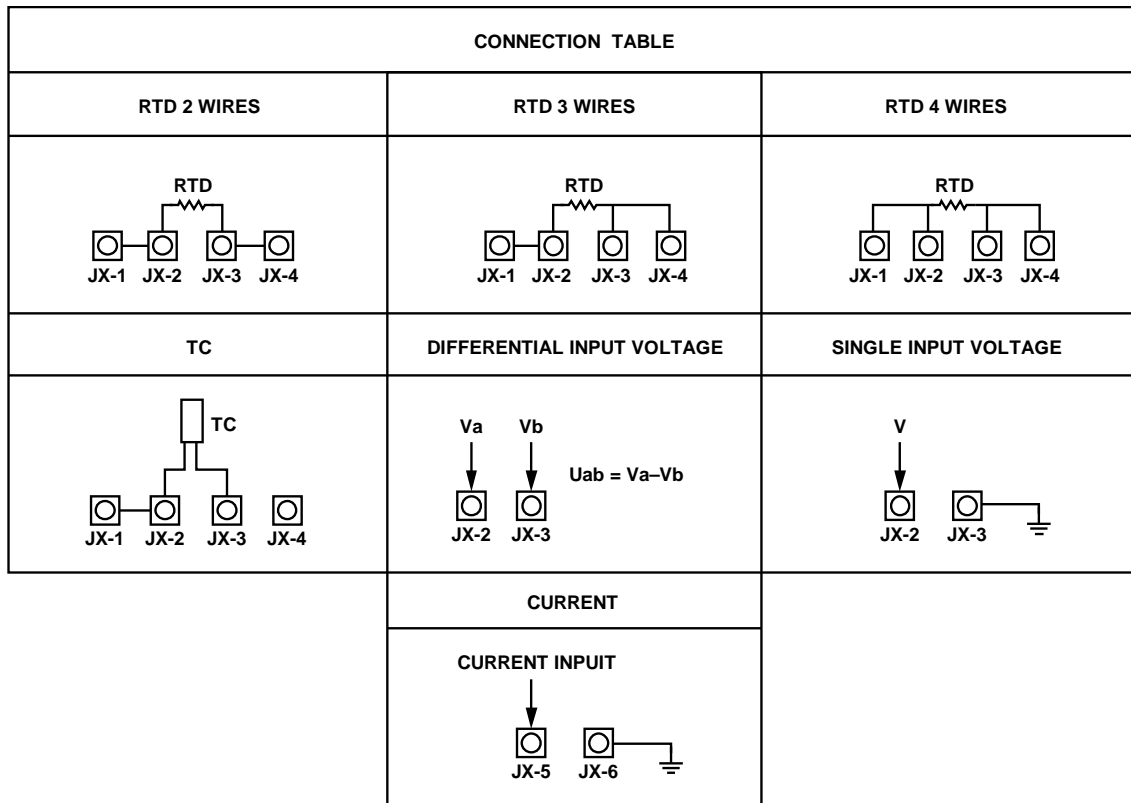

Figure 1. Universal Programmable Analog Front End for Process Control Applications (Simplified Schematic: All Connections and Decoupling Not Shown)



09839-002

Figure 2. Analog Input Configuration Table

available on the board. The resistor configuring the current source must have a low temperature coefficient to avoid drift errors in the measurement circuit.

### Thermocouple Measurement

In a thermocouple application, the voltage generated by the thermocouple is measured with respect to an absolute reference, provided externally to the ADC. The cold junction compensation is implemented using the [ADT7310](#) 16-bit temperature sensor. Because the signal from the thermocouple is small, and to maximize the dynamic range in the circuit, the AD7193 is operated at its highest gain range of 128. Because the input channel is buffered, large decoupling capacitors can be placed on the front end, if required, to eliminate any noise pickup that may be present in the thermocouple leads. The common-mode voltage for the thermocouple measurement is provided by the AD8617 amplifier.

### 4 mA-to-20 mA Current Measurement

This circuit also supports 4 mA-to-20 mA current measurement. The current is converted to a voltage using an on-board sense resistor. To use the full dynamic range of the ADC in the current measurement mode, a 200  $\Omega$  resistor is used.

The sense resistor must have a low temperature coefficient to avoid temperature drift errors in the measurement circuit.

### Regulator and Reference Selection

The [ADP1720](#) was chosen as the 5 V regulator for this circuit. The ADP1720 is a high voltage micropower linear regulator particularly suitable for industrial application.

The 4.5 V [REF194](#) was chosen as the reference for this circuit, and the E-grade device has an initial accuracy  $\pm 2$  mV at 25°C and a drift of 5 ppm/°C maximum. It is a low dropout device and consumes less than 45  $\mu$ A, with performance specifications over  $-40^{\circ}\text{C}$  to  $+125^{\circ}\text{C}$ .

### Isolation

The [ADuM1400](#) and the [ADuM1401](#) are quad-channel digital isolators based on Analog Devices' *iCoupler*® technology. These are used to provide isolation between the field side and the system microcontroller, with an isolation rating of 2.5 kV rms. Four wires are used through the ADuM1400, all for transmit (SCLK, DIN, ADG1414, ADT7310). Four wires are used through the ADuM1401: one for transmit (AD7193) and three for receive (INT1, INT2, DOUT). The DIN, DOUT, and SCLK lines are connected to the SPORT interface.

Table 1. Measured Performance Based on 1000 Samples

Input	AD7193 Configuration	RMS Noise (nV)	Effective Resolution (Bits)
±10V Input Range	Gain = 1; 50 Hz and 60 Hz rejection; output data rate = 50 Hz	7940	19.15
4 mA to 20 mA Range	Gain = 1; 50 Hz and 60 Hz rejection; output data rate = 2.63 Hz	931	22.24
RTD	Gain = 16; 50 Hz and 60 Hz rejection; output data rate = 2.63 Hz	243	20.29
Thermocouple	Gain = 128; 50 Hz and 60 Hz rejection; output data rate = 2.63 Hz	220	19.23

Figure 3 shows a histogram plot of the AD7193 output performance when configured in bipolar input mode with the inputs connected to ground. This histogram shows the effects of input-referred noise. The effective resolution achieved in this mode is 19.2 bits.

Table 1 shows the performance for other operating modes based on 1000 data samples from the ADC.

This design also includes external protection such as standard protection diodes and transient voltage suppressors (TVS devices) to enhance the robustness of the circuit. Refer to the schematics and other resources in the CN0209 Design Support Package: [www.analog.com/CN0209-DesignSupport](http://www.analog.com/CN0209-DesignSupport).

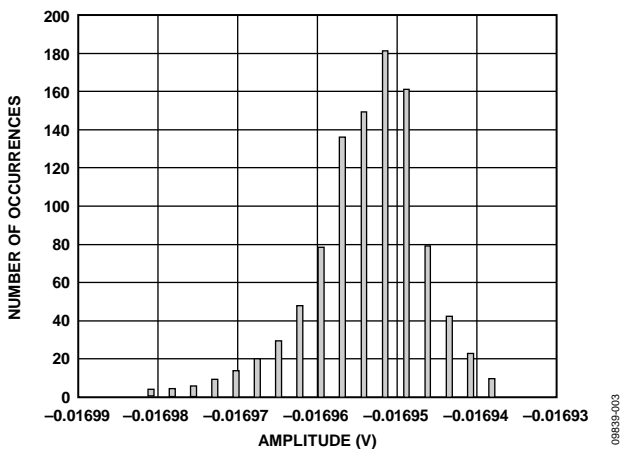

Figure 3. Noise Distribution Histogram, 1000 Samples  
AD7193 50 Hz Data Rate, Gain = 1, Input = 4.5 V Reference

## CIRCUIT EVALUATION AND TEST

This circuit uses the EVAL-CN0209-SDPZ circuit board and the EVAL-SDP-CB1Z System Demonstration Platform (SDP) evaluation board. The two boards have 120-pin mating connectors, allowing for the quick setup and evaluation of the circuit's performance. The EVAL-CN0209-SDPZ board contains the circuit to be evaluated, as described in this note, and the SDP evaluation board is used with the CN0209 evaluation software to capture the data from the EVAL-CN0209-SDPZ circuit board.

## Equipment Needed

- PC with a USB port and Windows® XP or Windows Vista® (32-bit) or Windows® 7 (32-bit)
- EVAL-CN0209-SDPZ Circuit Evaluation Board
- EVAL-SDP-CB1Z SDP Evaluation Board
- CN0209 Evaluation Software
- Power supply: +15 V and -15 V
- RTD temperature sensor
- Thermocouple

## Getting Started

Load the evaluation software by placing the CN0209 Evaluation Software disc in the CD drive of the PC. Using "My Computer," locate the drive that contains the evaluation software disc and open the Readme file. Follow the instructions contained in the Readme file for installing and using the evaluation software.

## Functional Block Diagram

See Figure 1 of this circuit note for the circuit block diagram, and the file "EVAL-CN0209-SDPZ-SCH-Rev0.pdf" for the circuit schematics. This file is contained in the CN0209 Design Support Package: [www.analog.com/CN0209-DesignSupport](http://www.analog.com/CN0209-DesignSupport).

## Setup

Connect the 120-pin connector on the EVAL-CN0209-SDPZ circuit board to the connector marked "CON A" on the EVAL-SDP-CB1Z evaluation (SDP) board. Nylon hardware should be used to firmly secure the two boards, using the holes provided at the ends of the 120-pin connectors. With power to the supply off, connect a +15 V power supply to the pin marked "+15 V," a -15V power supply to the pin marked "-15 V" and "GND" on the board. Connect the USB cable supplied with the SDP board to the USB port on the PC. Note: Do not connect the USB cable to the mini USB connector on the SDP board at this time.

## Test

Apply power to the ±15 V supply connected to the EVAL-CN0209-SDPZ circuit board. Launch the evaluation software and connect the USB cable from the PC to the USB mini-connector on the SDP board.

Once USB communications are established, the SDP board can now be used to send, receive, and capture serial data from the EVAL-CN0209-SDPZ board.

### Voltage Measurement

If you want to measure the noise of the voltage measurement circuit, connect both inputs J3 and J4 to the ground. Then, click on the button of the matching channel of the software: either V1 (if you are using channel 1) or V2 (if you are using channel 2).

If you want to measure a voltage, connect both inputs J3 and J4 as shown in Figure 2, the analog input configuration table. Then, click on the matching button of the software as previously explained.

Results are displayed as a waveform and a histogram. You have the option to select the scale of the voltage result between  $\mu\text{V}$ , mV, and V using the switching button.

### RTD Measurement

If you want to measure the temperature through an RTD temperature sensor, connect inputs J1, J2, J3, and J4 as shown in Figure 2. There are three different configurations of connection as you are using RTD 2-, 3-, or 4-wire. Then, click on the matching button of the software (RTD1 for channel 1, RTD2 for channel 2).

The switching button above the waveform allows you to display the result in Fahrenheit, Celsius, or Kelvin.

### Thermocouple Measurement

If you want to measure the temperature through a thermocouple, connect inputs J1, J2, J3, and J4 as shown in Figure 2. Select the type of thermocouple you are using (B, E, J, K, R, S, T, N). Then, click on the TC button of the software (TC1 for channel 1, TC 2 for channel 2).

The switching button above the waveform allows you to display the result in Fahrenheit, Celsius, or Kelvin.

### Current Measurement

If you want to measure a current, connect both inputs J5 and J6, as shown in Figure 2. Then, click on the matching button (I1 for channel 1, I2 for channel 2).

You can select the scale of the current result between  $\mu\text{A}$ , mA, and A using the switching button.

Information regarding the SDP board can be found in the [SDP User Guide](#).

(Continued from first page) Circuits from the Lab circuits are intended only for use with Analog Devices products and are the intellectual property of Analog Devices or its licensors. While you may use the Circuits from the Lab circuits in the design of your product, no other license is granted by implication or otherwise under any patents or other intellectual property by application or use of the Circuits from the Lab circuits. Information furnished by Analog Devices is believed to be accurate and reliable. However, "Circuits from the Lab" are supplied "as is" and without warranties of any kind, express, implied, or statutory including, but not limited to, any implied warranty of merchantability, noninfringement or fitness for a particular purpose and no responsibility is assumed by Analog Devices for their use, nor for any infringements of patents or other rights of third parties that may result from their use. Analog Devices reserves the right to change any Circuits from the Lab circuits at any time without notice but is under no obligation to do so.

©2011 Analog Devices, Inc. All rights reserved. Trademarks and registered trademarks are the property of their respective owners.  
CN09839-0-11/11(A)



www.analog.com

### LEARN MORE

MT-004 Tutorial, *The Good, the Bad, and the Ugly Aspects of ADC Input Noise—Is No Noise Good Noise?* Analog Devices.

MT-022 Tutorial, *ADC Architectures III: Sigma-Delta ADC Basics*, Analog Devices.

MT-023 Tutorial, *ADC Architectures IV: Sigma-Delta ADC Advanced Concepts and Applications*, Analog Devices.

MT-031 Tutorial, *Grounding Data Converters and Solving the Mystery of "AGND" and "DGND"*, Analog Devices.

MT-101 Tutorial, *Decoupling Techniques*, Analog Devices. *Sensor Signal Conditioning*, Analog Devices, 1999, Section 7.

### Data Sheets and Evaluation Boards

[ADuM1400 Data Sheet](#)

[ADuM1401 Data Sheet](#)

[AD7193 Data Sheet](#)

[AD7193 Evaluation Board](#)

[AD8275 Data Sheet](#)

[REF194 Data Sheet](#)

[AD8676 Data Sheet](#)

[AD8617 Data Sheet](#)

[ADG442 Data Sheet](#)

[ADG1414 Data Sheet](#)

[ADT7310 Data Sheet](#)

### REVISION HISTORY

11/11—Rev. 0 to Rev. A

Changes to Figure 2 .....3

4/11—Revision 0: Initial Version

Компания «Океан Электроники» предлагает заключение долгосрочных отношений при поставках импортных электронных компонентов на взаимовыгодных условиях!

Наши преимущества:

- Поставка оригинальных импортных электронных компонентов напрямую с производств Америки, Европы и Азии, а так же с крупнейших складов мира;
- Широкая линейка поставок активных и пассивных импортных электронных компонентов (более 30 млн. наименований);
- Поставка сложных, дефицитных, либо снятых с производства позиций;
- Оперативные сроки поставки под заказ (от 5 рабочих дней);
- Экспресс доставка в любую точку России;
- Помощь Конструкторского Отдела и консультации квалифицированных инженеров;
- Техническая поддержка проекта, помощь в подборе аналогов, поставка прототипов;
- Поставка электронных компонентов под контролем ВП;
- Система менеджмента качества сертифицирована по Международному стандарту ISO 9001;
- При необходимости вся продукция военного и аэрокосмического назначения проходит испытания и сертификацию в лаборатории (по согласованию с заказчиком);
- Поставка специализированных компонентов военного и аэрокосмического уровня качества (Xilinx, Altera, Analog Devices, Intersil, Interpoint, Microsemi, Actel, Aeroflex, Peregrine, VPT, Syfer, Eurofarad, Texas Instruments, MS Kennedy, Miteq, Cobham, E2V, MA-COM, Hittite, Mini-Circuits, General Dynamics и др.);

Компания «Океан Электроники» является официальным дистрибьютором и эксклюзивным представителем в России одного из крупнейших производителей разъемов военного и аэрокосмического назначения «**JONHON**», а так же официальным дистрибьютором и эксклюзивным представителем в России производителя высокотехнологичных и надежных решений для передачи СВЧ сигналов «**FORSTAR**».



## JONHON

«**JONHON**» (основан в 1970 г.)

Разъемы специального, военного и аэрокосмического назначения:

(Применяются в военной, авиационной, аэрокосмической, морской, железнодорожной, горно- и нефтедобывающей отраслях промышленности)

«**FORSTAR**» (основан в 1998 г.)

ВЧ соединители, коаксиальные кабели, кабельные сборки и микроволновые компоненты:

(Применяются в телекоммуникациях гражданского и специального назначения, в средствах связи, РЛС, а так же военной, авиационной и аэрокосмической отраслях промышленности).



Телефон: 8 (812) 309-75-97 (многоканальный)

Факс: 8 (812) 320-03-32

Электронная почта: [ocean@oceanchips.ru](mailto:ocean@oceanchips.ru)

Web: <http://oceanchips.ru/>

Адрес: 198099, г. Санкт-Петербург, ул. Калинина, д. 2, корп. 4, лит. А