LIN Bus Transceiver with Integrated Voltage Regulator

DATASHEET

Features

- Supply voltage up to 40V
- Operating voltage $V_S = 5V$ to 27V
- Typically 10 μ A supply current during sleep mode
- Typically 57 μ A Supply current in silent mode
- Linear low-drop voltage regulator, 85mA current capability:
 - Normal, fail-safe, and silent mode
 - Atmel® ATA6623C: $V_{CC} = 3.3V \pm 2\%$
 - Atmel ATA6625C: $V_{CC} = 5.0V \pm 2\%$
 - Sleep mode: V_{CC} is switched off
- V_{CC} undervoltage detection with reset open drain output NRES (4ms reset time)
- Voltage regulator is short-circuit and over-temperature protected
- LIN physical layer according to LIN 2.0, 2.1 and SAEJ2602-2
- Wake-up capability via LIN bus (90 μ s dominant)
- TXD time-out timer
- Bus pin is overtemperature and short-circuit protected versus GND and battery
- Advanced EMC and ESD performance
- Fulfills the OEM “Hardware Requirements for LIN in Automotive Applications Rev1.0”
- Interference and damage protection according to ISO7637
- Package: SO8

1. Description

The Atmel® ATA6623C/ATA6625C is a fully integrated LIN transceiver, designed according to the LIN specification 2.0 and 2.1, with a low-drop voltage regulator (3.3V/5V/85mA). The combination of voltage regulator and bus transceiver makes it possible to develop simple, but powerful, slave nodes in LIN Bus systems. The Atmel ATA6623C/ATA6625C is designed to handle the low-speed data communication in vehicles (for example, in convenience electronics). Improved slope control at the LIN driver ensures secure data communication up to 20kBaud with an RC oscillator for the protocol handling. The bus output is designed to withstand high voltage. Sleep mode (voltage regulator switched off) and silent mode (communication off; V_{CC} voltage on) guarantee minimized current consumption.

Figure 1-1. Block Diagram

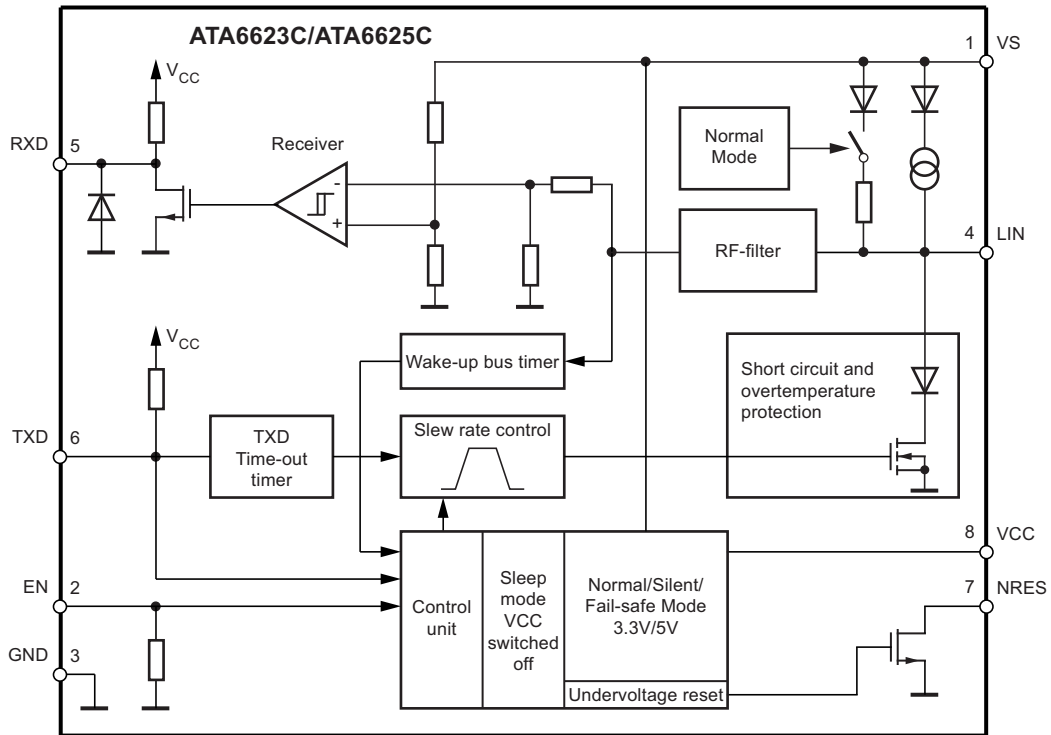

2. Pin Configuration

Figure 2-1. Pinning SO8

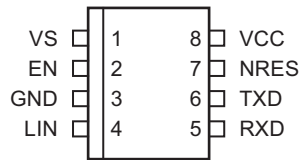

Table 2-1. Pin Description

Pin	Symbol	Function
1	VS	Battery supply
2	EN	Enables normal mode if the input is high
3	GND	Ground, heat sink
4	LIN	LIN bus line input/output
5	RXD	Receive data output
6	TXD	Transmit data input
7	NRES	Output undervoltage reset, low at reset
8	VCC	Output voltage regulator 3.3V/5V/85mA

3. Functional Description

3.1 Physical Layer Compatibility

Since the LIN physical layer is independent from higher LIN layers (e.g., LIN protocol layer), all nodes with a LIN physical layer according to revision 2.x can be mixed with LIN physical layer nodes, which are according to older versions (i.e., LIN 1.0, LIN 1.1, LIN 1.2, LIN 1.3) without any restrictions.

3.2 Supply Pin (VS)

LIN operating voltage is $V_S = 5V$ to $27V$. An undervoltage detection is implemented to disable transmission if V_S falls below $5V$, in order to avoid false bus messages. After switching on V_S , the IC starts with the fail-safe mode and the voltage regulator is switched on.

The supply current in sleep mode is typically $10\mu A$ and $57\mu A$ in silent mode.

3.3 Ground Pin (GND)

The IC does not affect the LIN Bus in the event of GND disconnection. It is able to handle a ground shift up to 11.5% of V_S .

3.4 Voltage Regulator Output Pin (VCC)

The internal 3.3V/5V voltage regulator is capable of driving loads up to $85mA$, supplying the microcontroller and other ICs on the PCB and is protected against overload by means of current limitation and overtemperature shut-down. Furthermore, the output voltage is monitored and will cause a reset signal at the NRES output pin if it drops below a defined threshold V_{thun} .

3.5 Undervoltage Reset Output (NRES)

If the V_{CC} voltage falls below the undervoltage detection threshold of V_{thun} , NRES switches to low after t_{res_f} (Figure 6-1 on page 11). Even if $V_{CC} = 0V$ the NRES stays low, because it is internally driven from the V_S voltage. If V_S voltage ramps down, NRES stays low until $V_S < 1.5V$ and then becomes highly resistant.

The implemented undervoltage delay keeps NRES low for $t_{Reset} = 4ms$ after V_{CC} reaches its nominal value.

3.6 Bus Pin (LIN)

A low-side driver with internal current limitation and thermal shutdown as well as an internal pull-up resistor according to LIN specification 2.x is implemented. The voltage range is from $-27V$ to $+40V$. This pin exhibits no reverse current from the LIN bus to V_S , even in the event of a GND shift or V_{Batt} disconnection. The LIN receiver thresholds are compatible with the LIN protocol specification.

The fall time (from recessive to dominant) and the rise time (from dominant to recessive) are slope controlled.

3.7 Input Pin (TXD)

In normal mode the TXD pin is the microcontroller interface to control the state of the LIN output. TXD must be pulled to ground in order to drive the LIN bus low. If TXD is high or unconnected (internal pull-up resistor), the LIN output transistor is turned off and the bus is in the recessive state.

3.8 Dominant Time-out Function (TXD)

The TXD input has an internal pull-up resistor. An internal timer prevents the bus line from being driven permanently in the dominant state. If TXD is forced to low longer than $t_{dom} > 6ms$, the LIN bus driver is switched to the recessive state.

To reactivate the LIN bus driver, switch TXD to high ($> 10\mu s$).

3.9 Output Pin (RXD)

This output pin reports the state of the LIN-bus to the microcontroller. LIN high (recessive state) is reported by a high level at RXD; LIN low (dominant state) is reported by a low level at RXD. The output has an internal pull-up resistor with typically $5k\Omega$ to V_{CC} . The AC characteristics are measured with an external load capacitor of $20pF$.

The output is short-circuit protected. In unpowered mode (that is, $V_S = 0V$), RXD is switched off.

3.10 Enable Input Pin (EN)

The Enable Input pin controls the operation mode of the device. If EN is high, the circuit is in normal mode, with transmission paths from TXD to LIN and from LIN to RXD both active. The VCC voltage regulator operates with 3.3V/5V/85mA output capability.

If EN is switched to low while TXD is still high, the device is forced to silent mode. No data transmission is then possible, and the current consumption is reduced to I_{VS} typ. 57µA. The VCC regulator has its full functionality.

If EN is switched to low while TXD is low, the device is forced to sleep mode. No data transmission is possible, and the voltage regulator is switched off.

4. Modes of Operation

Figure 4-1. Modes of Operation

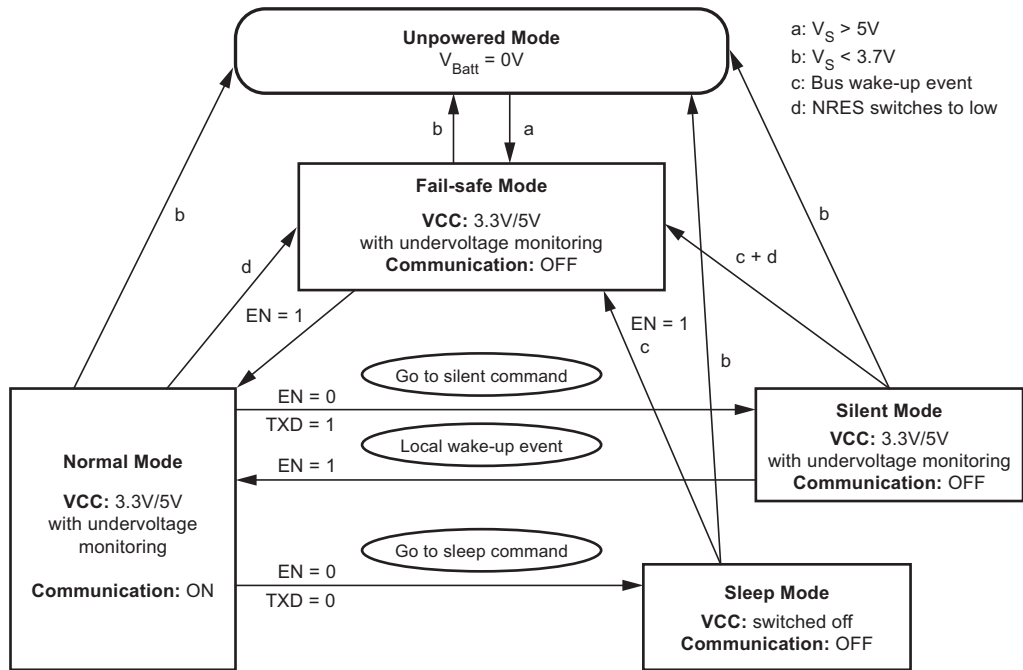

Table 4-1. Modes of Operation

Mode of Operation	Transceiver	V _{CC}	RXD	LIN
Fail safe	OFF	3.3V/5V	High, Except after wake-up	Recessive
Normal	ON	3.3V/5V	LIN depending	TXD depending
Silent	OFF	3.3V/5V	High	Recessive
Sleep	OFF	0V	0V	Recessive

4.1 Normal Mode

This is the normal transmitting and receiving mode of the LIN Interface, in accordance with LIN specification 2.x. The V_{CC} voltage regulator operates with a 3.3V/5V output voltage, with a low tolerance of $\pm 2\%$ and a maximum output current of 85mA.

If an undervoltage condition occurs, NRES is switched to low and the IC changes its state to fail-safe mode.

4.2 Silent Mode

A falling edge at EN while TXD is high switches the IC into silent mode. The TXD Signal has to be logic high during the mode select window (Figure 4-2 on page 6). The transmission path is disabled in silent mode. The overall supply current from V_{Batt} is a combination of the $I_{V_{Ssi}} = 57\mu A$ plus the V_{CC} regulator output current $I_{V_{CC}}$.

In silent mode the internal slave termination between pin LIN and pin VS is disabled, and only a weak pull-up current (typically $10\mu A$) between pin LIN and pin VS is present. The silent mode can be activated independently from the current level on pin LIN.

If an undervoltage condition occurs, NRES is switched to low and the IC changes its state to fail-safe mode.

A voltage less than the LIN Pre-wake detection V_{LINL} at pin LIN activates the internal LIN receiver and switches on the internal slave termination between the LIN pin and the VS pin.

A falling edge at the LIN pin followed by a dominant bus level maintained for a certain time period ($> t_{bus}$) and the following rising edge at pin LIN (see Figure 4-3 on page 7) results in a remote wake-up request.

The device switches from silent mode to fail-safe mode, and the remote wake-up request is indicated by a low level at pin RXD to interrupt the microcontroller (Figure 4-3 on page 7). EN high can be used to switch directly to normal mode.

Figure 4-2. Switch to Silent Mode

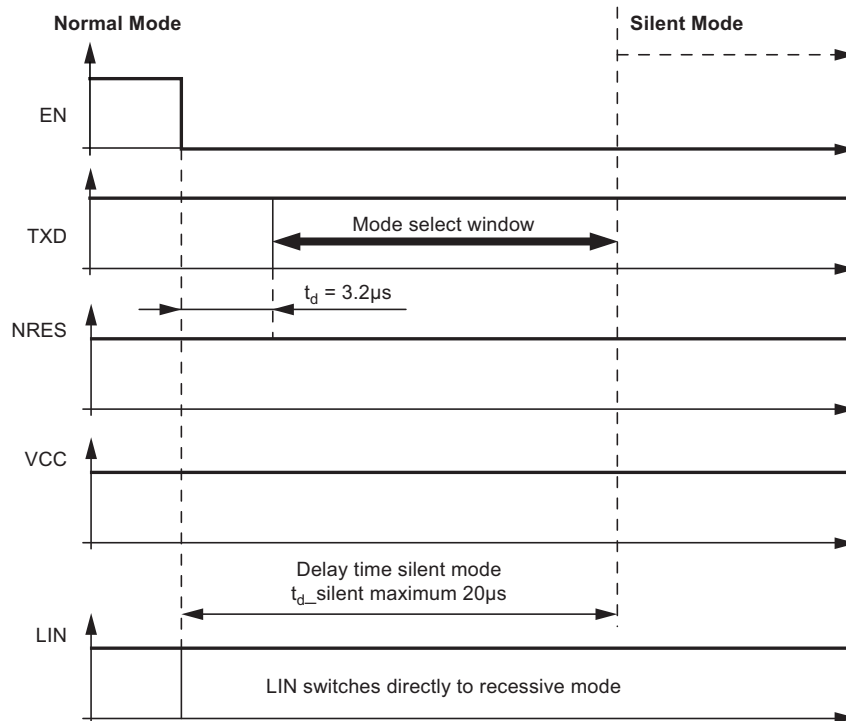
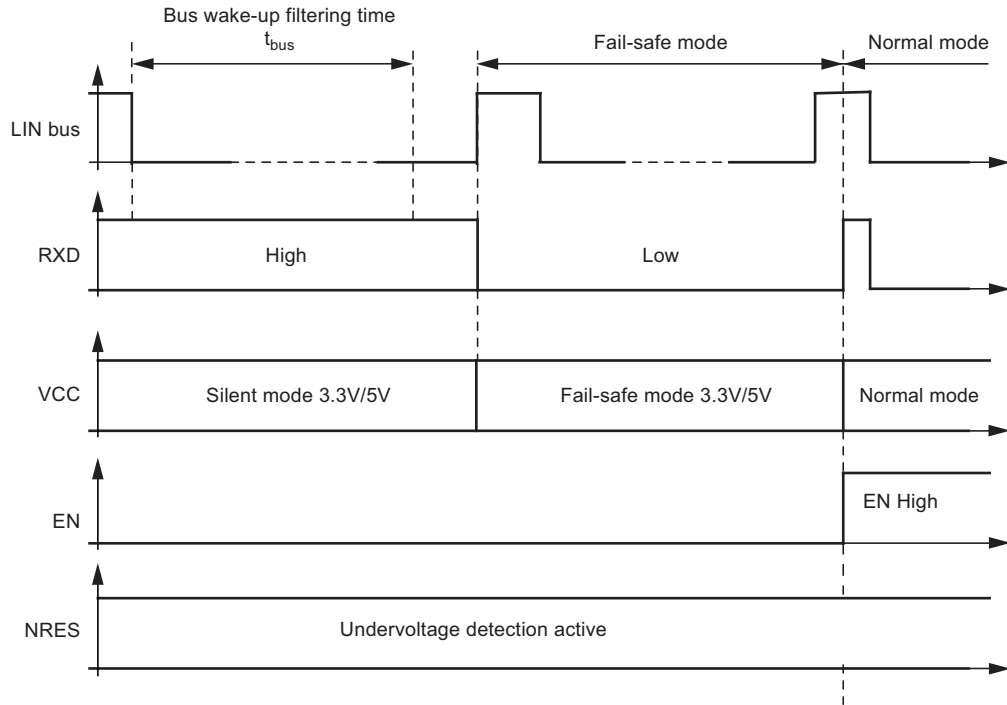

Figure 4-3. LIN Wake-up Waveform Diagram from Silent Mode



4.3 Sleep Mode

A falling edge at EN while TXD is low switches the IC into sleep mode. The TXD Signal has to be logic low during the mode select window (Figure 4-4 on page 8). To avoid influencing the LIN-pin during the switch to sleep mode, it is possible to switch the EN up to 3.2µs earlier to LOW than the TXD. Even if the two falling edges at TXD and EN occur at the same time, the LIN line will remain uninfluenced.

In sleep mode the transmission path is disabled. The supply current $I_{V_{SS}sleep}$ from V_{Batt} is typically 10µA. The V_{CC} regulator is switched off, NRES and RXD are low. The internal slave termination between pin LIN and pin VS is disabled, only a weak pull-up current (typically 10µA) between pin LIN and pin VS is present. sleep mode can be activated independently from the current level on pin LIN.

A voltage less than the LIN Pre-wake detection V_{LINL} at pin LIN activates the internal LIN receiver and switches on the internal slave termination between the LIN pin and the VS pin.

A falling edge at the LIN pin followed by a dominant bus level maintained for a certain time period ($> t_{bus}$) and a following rising edge at pin LIN results in a remote wake-up request. The device switches from sleep mode to fail-safe mode.

The V_{CC} regulator is activated, and the remote wake-up request is indicated by a low level at the RXD pin to interrupt the microcontroller (Figure 4-5 on page 9).

EN high can be used to switch directly from sleep to fail-safe mode. If EN is still high after VCC ramp up and undervoltage reset time, the IC switches to normal mode.

Figure 4-4. Switch to Sleep Mode

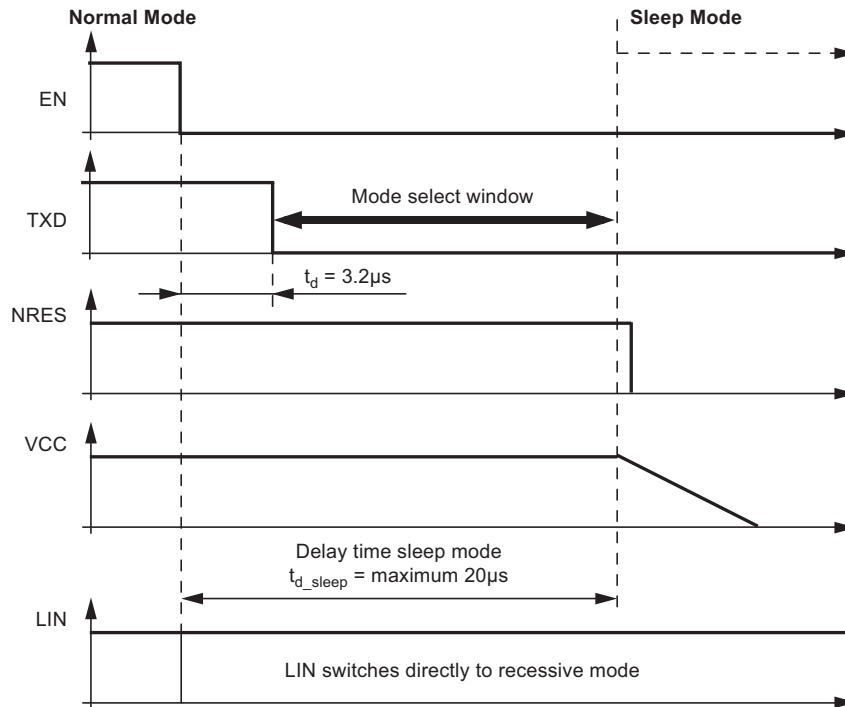
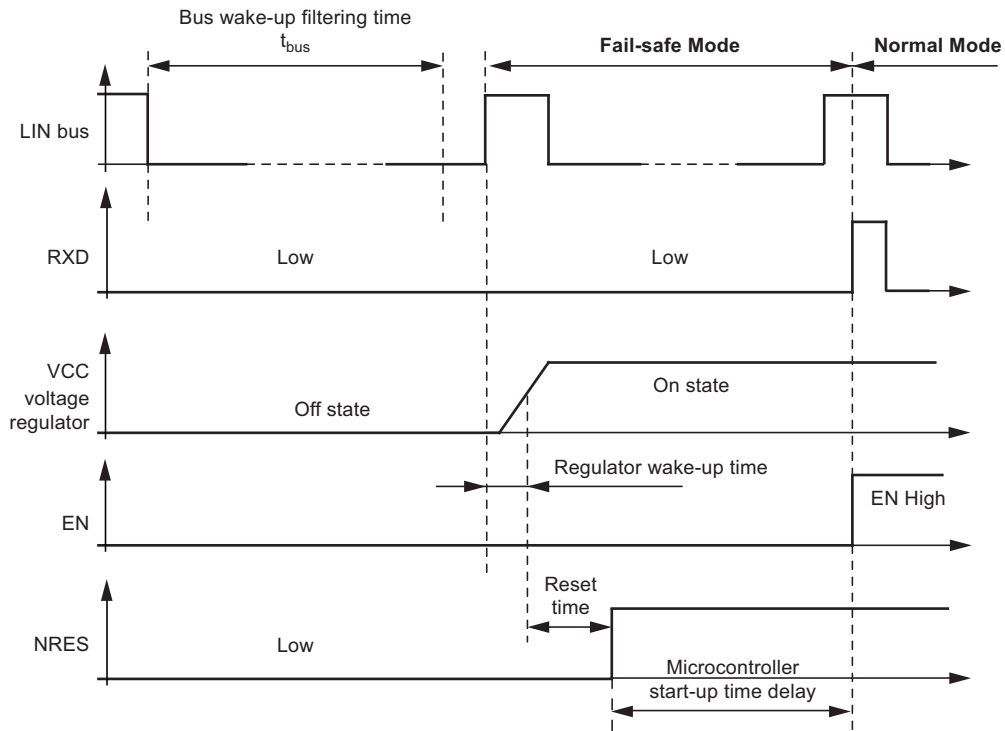

Figure 4-5. LIN Wake-up Diagram from Sleep Mode



4.4 Fail-safe Mode

At system power-up the device automatically switches to fail-safe mode. The voltage regulator is switched on (see [Figure 6-1 on page 11](#)). The NRES output switches to low for $t_{res} = 4\text{ms}$ and gives a reset to the microcontroller. LIN communication is switched off. The IC stays in this mode until EN is switched to high, and changes then to the normal mode. A power down of V_{Batt} ($V_S < 3.7\text{V}$) during silent or sleep mode switches the IC into the fail-safe mode after power up. A logic low at NRES switches the IC into fail-safe mode directly.

4.5 Unpowered Mode

If you connect battery voltage to the application circuit, the voltage at the VS pin increases according to the block capacitor (see [Figure 6-1 on page 11](#)). After VS is higher than the VS undervoltage threshold $V_{S_{th}}$, the IC mode changes from unpowered mode to fail-safe mode. The VCC output voltage reaches its nominal value after t_{VCC} . This time, t_{VCC} , depends on the VCC capacitor and the load.

NRES is low for the reset time delay t_{Reset} ; no mode change is possible during this time.

5. Fail-safe Features

- During a short-circuit at LIN to V_{Battery} , the output limits the output current to $I_{\text{BUS_lim}}$. Due to the power dissipation, the chip temperature exceeds T_{LINoff} and the LIN output is switched off. The chip cools down and after a hysteresis of T_{hys} , switches the output on again. RXD stays on high because LIN is high. During LIN overtemperature switch-off, the V_{CC} regulator is working independently.
- During a short-circuit from LIN to GND the IC can be switched into sleep or silent mode. If the short-circuit disappears, the IC starts with a remote wake-up.
- The reverse current is very low $< 2\mu\text{A}$ at pin LIN during loss of V_{Batt} . This is optimal behavior for bus systems where some slave nodes are supplied from battery or ignition.
- During a short circuit at VCC, the output limits the output current to I_{VCClim} . Because of undervoltage, NRES switches to low and sends a reset to the microcontroller. The IC switches into fail-safe mode. If the chip temperature exceeds the value T_{VCCoff} , the V_{CC} output switches off. The chip cools down and after a hysteresis of T_{hys} , switches the output on again. Because of fail-safe mode, the V_{CC} voltage will switch on again although EN is switched off from the microcontroller. The microcontroller can then start with normal operation.
- Pin EN provides a pull-down resistor to force the transceiver into recessive mode if EN is disconnected.
- Pin RXD is set floating if V_{Batt} is disconnected.
- Pin TXD provides a pull-up resistor to force the transceiver into recessive mode if TXD is disconnected.
- If TXD is short-circuited to GND, it is possible to switch to sleep mode via ENABLE after $t_{\text{dom}} > 20\text{ms}$.

6. Voltage Regulator

Figure 6-1. V_{CC} Voltage Regulator: Ramp Up and Undervoltage

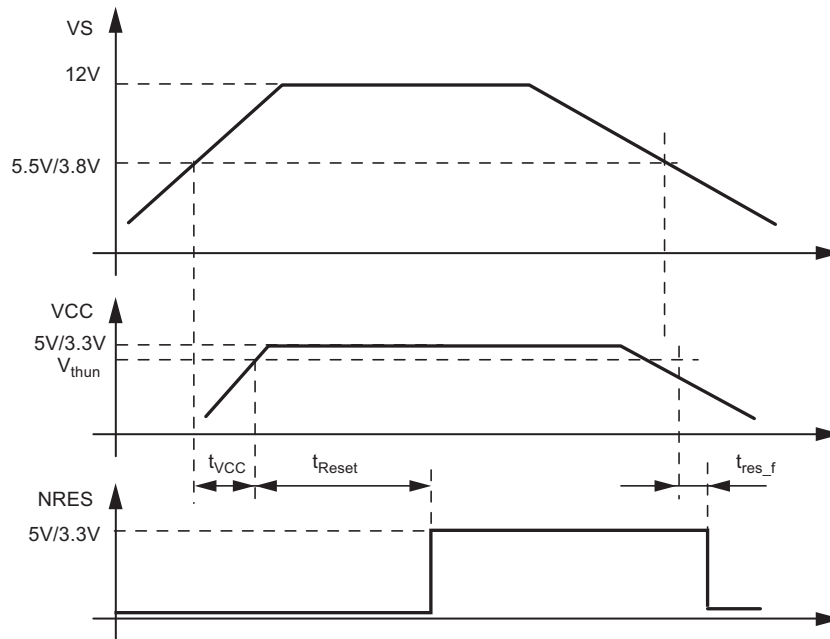

The voltage regulator needs an external capacitor for compensation and to smooth the disturbances from the microcontroller. It is recommended to use an electrolytic capacitor with $C > 1.8\mu F$ and a ceramic capacitor with $C = 100nF$. The values of these capacitors can be varied by the customer, depending on the application.

With this special SO8 package (fused lead frame to pin 3) an R_{thja} of 80K/W is achieved.

Therefore, it is recommended to connect pin 3 with a wide GND plate on the printed board to get a good heat sink.

The main power dissipation of the IC is created from the V_{CC} output current I_{VCC} , which is needed for the application.

Figure 6-2 shows the safe operating area of the Atmel® ATA6625C.

Figure 6-2. Power Dissipation: Safe Operating Area: V_{CC} Output Current versus Supply Voltage V_S at Different Ambient Temperatures Due to $R_{thja} = 80K/W$

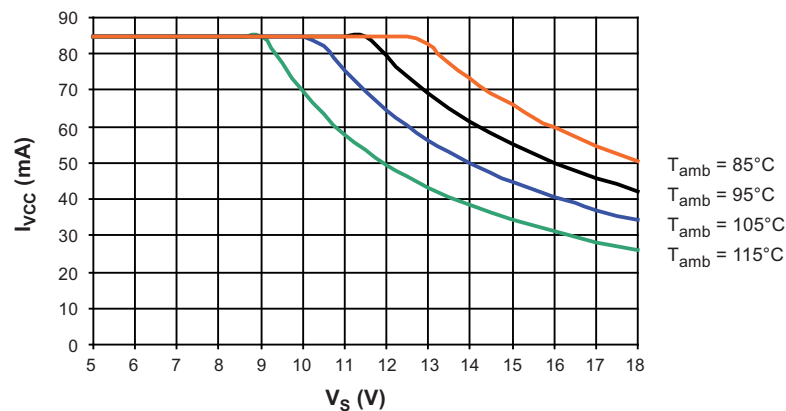

To program the microcontroller it may be necessary to supply the V_{CC} output via an external power supply while the V_S Pin of the system basis chip is disconnected. This will not affect the system basis chip.

7. Absolute Maximum Ratings

Stresses beyond those listed under “Absolute Maximum Ratings” may cause permanent damage to the device. This is a stress rating only and functional operation of the device at these or any other conditions beyond those indicated in the operational sections of this specification is not implied. Exposure to absolute maximum rating conditions for extended periods may affect device reliability.

Parameters	Symbol	Min.	Typ.	Max.	Unit
Supply voltage V_S	V_S	-0.3		+40	V
Pulse time $\leq 500\text{ms}$ $T_a = 25^\circ\text{C}$ Output current $I_{VCC} \leq 85\text{mA}$	V_S			+40	V
Pulse time $\leq 2\text{min}$ $T_a = 25^\circ\text{C}$ Output current $I_{VCC} \leq 85\text{mA}$	V_S			27	V
Logic pins (RxD, TxD, EN, NRES)		-0.3		+5.5	V
Output current NRES	I_{NRES}			+2	mA
LIN - DC voltage		-27		+40	V
V_{CC} - DC voltage		-0.3		+5.5	V
ESD according to IBEE LIN EMC Test specification 1.0 following IEC 61000-4-2 - Pin VS, LIN to GND		± 6			KV
ESD HBM following STM5.1 with $1.5\text{k}\Omega/100\text{pF}$ - Pin VS, LIN to GND		± 6			KV
HBM ESD ANSI/ESD-STM5.1 JESD22-A114 AEC-Q100 (002)		± 3			KV
CDM ESD STM 5.3.1		± 750			V
Machine Model ESD AEC-Q100-RevF(003)		± 200			V
Junction temperature	T_j	-40		+150	$^\circ\text{C}$
Storage temperature	T_s	-55		+150	$^\circ\text{C}$

8. Thermal Characteristics

Parameters	Symbol	Min.	Typ.	Max.	Unit
Thermal resistance junction to ambient (free air)	R_{thja}			145	K/W
Special heat sink at GND (pin 3) on PCB	R_{thja}		80		K/W
Thermal shutdown of V_{CC} regulator	T_{VCCoff}	150	160	170	$^\circ\text{C}$
Thermal shutdown of LIN output	T_{LINoff}	150	160	170	$^\circ\text{C}$
Thermal shutdown hysteresis	T_{hys}		10		$^\circ\text{C}$

9. Electrical Characteristics

$5V < V_S < 27V$, $-40^{\circ}C < T_j < 150^{\circ}C$; unless otherwise specified all values refer to GND pins.

No.	Parameters	Test Conditions	Pin	Symbol	Min.	Typ.	Max.	Unit	Type*
1 VS Pin									
1.1	Nominal DC voltage range		VS	V_S	5	13.5	27	V	A
1.2	Supply current in sleep mode	Sleep mode $V_{LIN} > V_S - 0.5V$ $V_S < 14V$ ($T_j = 25^{\circ}C$)	VS	$I_{VSsleep}$	3	10	14	μA	B
		Sleep mode $V_{LIN} > V_S - 0.5V$ $V_S < 14V$ ($T_j = 125^{\circ}C$)	VS	$I_{VSsleep}$	5	11	16	μA	A
1.3	Supply current in silent mode	Bus recessive $V_S < 14V$ ($T_j = 25^{\circ}C$) Without load at VCC	VS	I_{VSSi}	47	57	67	μA	B
		Bus recessive $V_S < 14V$ ($T_j = 125^{\circ}C$) Without load at VCC	VS	I_{VSSi}	56	66	76	μA	A
1.4	Supply current in normal mode	Bus recessive $V_S < 14V$ Without load at VCC	VS	I_{VSrec}	0.3		0.8	mA	A
1.5	Supply current in normal mode	Bus dominant $V_S < 14V$ VCC load current 50mA	VS	I_{VSdom}	50		53	mA	A
1.6	Supply current in fail-safe mode	Bus recessive $V_S < 14V$ Without load at VCC	VS	I_{VSpeed}	200		500	μA	A
1.7	V_S undervoltage threshold		VS	V_{Sth}	3.7	4.4	5	V	A
1.8	V_S undervoltage threshold hysteresis		VS	V_{Sth_hys}		0.2		V	A
2 RXD Output Pin									
2.1	Low level output sink current	Normal mode $V_{LIN} = 0V$ $V_{RXD} = 0.4V$	RXD	I_{RXD}	1.3	2.5	8	mA	A
2.2	Low level output voltage	$I_{RXD} = 1mA$	RXD	V_{RXDL}			0.4	V	A
2.3	Internal resistor to VCC		RXD	R_{RXD}	3	5	7	k Ω	A
3 TXD Input Pin									
3.1	Low level voltage input		TXD	V_{TXDL}	-0.3		+0.8	V	A
3.2	High level voltage input		TXD	V_{TXDH}	2		$V_{CC} + 0.3V$	V	A
3.3	Pull-up resistor	$V_{TXD} = 0V$	TXD	R_{TXD}	125	250	400	k Ω	A
3.4	High level leakage current	$V_{TXD} = V_{CC}$	TXD	I_{TXD}	-3		+3	μA	A

*) Type means: A = 100% tested, B = 100% correlation tested, C = Characterized on samples, D = Design parameter

9. Electrical Characteristics (Continued)

5V < V_S < 27V, -40°C < T_j < 150°C; unless otherwise specified all values refer to GND pins.

No.	Parameters	Test Conditions	Pin	Symbol	Min.	Typ.	Max.	Unit	Type*
4 EN Input Pin									
4.1	Low level voltage input		EN	V _{ENL}	-0.3		+0.8	V	A
4.2	High level voltage input		EN	V _{ENH}	2		V _{CC} + 0.3V	V	A
4.3	Pull-down resistor	V _{EN} = V _{CC}	EN	R _{EN}	50	125	200	kΩ	A
4.4	Low level input current	V _{EN} = 0V	EN	I _{EN}	-3		+3	μA	A
5 NRES Open Drain Output Pin									
5.1	Low level output voltage	V _S ≥ 5.5V I _{NRES} = 1mA	NRES	V _{NRESL}			0.14	V	A
5.2	Low level output low	10kΩ to 5V V _{CC} = 0V	NRES	V _{NRESLL}			0.14	V	A
5.3	Undervoltage reset time	V _S ≥ 5.5V C _{NRES} = 20pF	NRES	t _{Reset}	2	4	6	ms	A
5.4	Reset debounce time for falling edge	V _S ≥ 5.5V C _{NRES} = 20pF	NRES	t _{res_f}	1.5		10	μs	A
6 VCC Voltage Regulator Atmel ATA6623C									
6.1	Output voltage V _{CC}	4V < V _S < 18V (0mA to 50mA)	VCC	V _{CCnor}	3.234		3.366	V	A
		4.5V < V _S < 18V (0mA to 85mA)	VCC	V _{CCnor}	3.234		3.366	V	C
6.2	Output voltage V _{CC} at low V _S	3V < V _S < 4V	VCC	V _{CClow}	V _S - V _{Drop}		3.366	V	A
6.3	Regulator drop voltage	V _S > 3V, I _{VCC} = -15mA	VCC	V _{D1}			200	mV	A
6.4	Regulator drop voltage	V _S > 3V, I _{VCC} = -50mA	VCC	V _{D2}		500	700	mV	A
6.5	Line regulation	4V < V _S < 18V	VCC	V _{CCline}		0.1	0.2	%	A
6.6	Load regulation	5mA < I _{VCC} < 50mA	VCC	V _{CCload}		0.1	0.5	%	A
6.7	Power supply ripple rejection	10Hz to 100kHz C _{VCC} = 10μF V _S = 14V, I _{VCC} = -15mA	VCC		50			dB	D
6.8	Output current limitation	V _S > 4V	VCC	I _{VCClim}	-240	-160	-85	mA	A
6.9	External load capacity	0.2Ω < ESR < 5Ω at 100kHz for phase margin ≥ 60°	VCC	C _{load}	1.8	10		μF	D
		ESR < 0.2Ω at 100kHz for phase margin ≥ 30°							
6.10	VCC undervoltage threshold	Referred to VCC V _S > 4V	VCC	V _{thunN}	2.8		3.2	V	A
6.11	Hysteresis of undervoltage threshold	Referred to VCC V _S > 4V	VCC	V _{hys_thun}		150		mV	A
6.12	Ramp up time V _S > 4V to V _{CC} = 3.3V	C _{VCC} = 2.2μF I _{load} = -5mA at VCC	VCC	t _{VCC}		100	250	μs	A

*) Type means: A = 100% tested, B = 100% correlation tested, C = Characterized on samples, D = Design parameter

9. Electrical Characteristics (Continued)

5V < V_S < 27V, -40°C < T_J < 150°C; unless otherwise specified all values refer to GND pins.

No.	Parameters	Test Conditions	Pin	Symbol	Min.	Typ.	Max.	Unit	Type*
7 VCC Voltage Regulator Atmel ATA6625C									
7.1	Output voltage VCC	5.5V < V _S < 18V (0mA to 50mA)	VCC	VCC _{nor}	4.9		5.1	V	A
		6V < V _S < 18V (0mA to 85mA)	VCC	VCC _{nor}	4.9		5.1	V	C
7.2	Output voltage V _{CC} at low V _S	4V < V _S < 5.5V	VCC	VCC _{low}	V _S - V _D		5.1	V	A
7.3	Regulator drop voltage	V _S > 4V, I _{VCC} = -20mA	VCC	V _{D1}			250	mV	A
7.4	Regulator drop voltage	V _S > 4V, I _{VCC} = -50mA	VCC	V _{D2}		400	600	mV	A
7.5	Regulator drop voltage	V _S > 3.3V, I _{VCC} = -15mA	VCC	V _{D3}			200	mV	A
7.6	Line regulation	5.5V < V _S < 18V	VCC	VCC _{line}		0.1	0.2	%	A
7.7	Load regulation	5mA < I _{VCC} < 50mA	VCC	VCC _{load}		0.1	0.5	%	A
7.8	Power supply ripple rejection	10Hz to 100kHz C _{VCC} = 10μF V _S = 14V, I _{VCC} = -15mA	VCC		50			dB	D
7.9	Output current limitation	V _S > 5.5V	VCC	I _{VCClim}	-240	-160	-85	mA	A
7.10	External load capacity	0.2Ω < ESR < 5Ω at 100kHz for phase margin ≥ 60°	VCC	C _{load}	1.8	10		μF	D
		ESR < 0.2Ω at 100kHz for phase margin ≥ 30°							
7.11	VCC undervoltage threshold	Referred to VCC V _S > 5.5V	VCC	V _{thunN}	4.2		4.8	V	A
7.12	Hysteresis of undervoltage threshold	Referred to VCC V _S > 5.5V	VCC	V _{hys} _{thun}		250		mV	A
7.13	Ramp up time V _S > 5.5V to VCC = 5V	C _{VCC} = 2.2μF I _{load} = -5mA at VCC	VCC	t _{VCC}		130	300	μs	A
8 LIN Bus Driver: Bus Load Conditions: Load 1 (Small): 1nF, 1kΩ, Load 2 (Large): 10nF, 500Ω, Internal Pull-up R_{RXD} = 5kΩ, C_{RXD} = 20pF, Load 3 (Medium): 6.8nF, 660Ω, Characterized on Samples 10.6 and 10.7 Specifies the Timing Parameters for Proper Operation at 20kBit/s and 10.8 and 10.9 at 10.4kBit/s									
8.1	Driver recessive output voltage	Load1/Load2	LIN	V _{BUSrec}	0.9 × V _S		V _S	V	A
8.2	Driver dominant voltage	V _{V_S} = 7V, R _{load} = 500Ω	LIN	V _{LoSUP}			1.2	V	A
8.3	Driver dominant voltage	V _{V_S} = 18V, R _{load} = 500Ω	LIN	V _{HiSUP}			2	V	A
8.4	Driver dominant voltage	V _{V_S} = 7V, R _{load} = 1000Ω	LIN	V _{LoSUP_1k}	0.6			V	A
8.5	Driver dominant voltage	V _{V_S} = 18V, R _{load} = 1000Ω	LIN	V _{HiSUP_1k}	0.8			V	A
8.6	Pull-up resistor to V _S	The serial diode is mandatory	LIN	R _{LIN}	20	30	60	kΩ	A
8.7	Voltage drop at the serial diodes	In pull-up path with R _{slave} I _{SerDiode} = 10mA	LIN	V _{SerDiode}	0.4		1.0	V	D
8.8	LIN current limitation V _{BUS} = V _{Batt_max}		LIN	I _{BUS_lim}	40	120	200	mA	A

*) Type means: A = 100% tested, B = 100% correlation tested, C = Characterized on samples, D = Design parameter

9. Electrical Characteristics (Continued)

5V < V_S < 27V, -40°C < T_J < 150°C; unless otherwise specified all values refer to GND pins.

No.	Parameters	Test Conditions	Pin	Symbol	Min.	Typ.	Max.	Unit	Type*
8.9	Input leakage current at the receiver including pull-up resistor as specified	Input Leakage current Driver off V _{BUS} = 0V V _{Batt} = 12V	LIN	I _{BUS_PAS_do} m	-1	-0.35		mA	A
8.10	Leakage current LIN recessive	Driver off 8V < V _{Batt} < 18V 8V < V _{BUS} < 18V V _{BUS} ≥ V _{Batt}	LIN	I _{BUS_PAS_rec}		10	20	μA	A
8.11	Leakage current when control unit disconnected from ground. Loss of local ground must not affect communication in the residual network	GND _{Device} = V _S V _{Batt} = 12V 0V < V _{BUS} < 18V	LIN	I _{BUS_NO_gnd}	-10	+0.5	+10	μA	A
8.12	Leakage current at disconnected battery. Node has to sustain the current that can flow under this condition. Bus must remain operational under this condition.	V _{Batt} disconnected V _{SUP_Device} = GND 0V < V _{BUS} < 18V	LIN	I _{BUS_NO_bat}		0.1	2	μA	A
8.13	Capacitance on Pin LIN to GND		LIN	C _{LIN}			20	pF	D
9 LIN Bus Receiver									
9.1	Center of receiver threshold	V _{BUS_CNT} = (V _{th_dom} + V _{th_rec})/2	LIN	V _{BUS_CNT}	0.475 × V _S	0.5 × V _S	0.525 × V _S	V	A
9.2	Receiver dominant state	V _{EN} = 5V	LIN	V _{BUSdom}	-27		0.4 × V _S	V	A
9.3	Receiver recessive state	V _{EN} = 5V	LIN	V _{BUSrec}	0.6 × V _S		40	V	A
9.4	Receiver input hysteresis	V _{hys} = V _{th_rec} - V _{th_dom}	LIN	V _{BUShys}	0.028 × V _S	0.1 × V _S	0.175 × V _S	V	A
9.5	Pre-wake detection LIN High level input voltage		LIN	V _{LINH}	V _S - 2V		V _S + 0.3V	V	A
9.6	Pre-wake detection LIN Low level input voltage	Activates the LIN receiver	LIN	V _{LINL}	-27		V _S - 3.3V	V	A
10 Internal Timers									
10.1	Dominant time for wake-up via LIN bus	V _{LIN} = 0V	LIN	t _{bus}	30	90	150	μs	A
10.2	Time delay for mode change from Fail-safe into normal mode via pin EN	V _{EN} = 5V	EN	t _{norm}	5		20	μs	A
10.3	Time delay for mode change from normal mode to sleep mode via pin EN	V _{EN} = 0V	EN	t _{sleep}	2	7	15	μs	A

*) Type means: A = 100% tested, B = 100% correlation tested, C = Characterized on samples, D = Design parameter

9. Electrical Characteristics (Continued)

5V < V_S < 27V, -40°C < T_j < 150°C; unless otherwise specified all values refer to GND pins.

No.	Parameters	Test Conditions	Pin	Symbol	Min.	Typ.	Max.	Unit	Type*
10.4	TXD dominant time out time	V _{TXD} = 0V	TXD	t _{dom}	6	13	20	ms	A
10.5	Time delay for mode change from silent mode into normal mode via EN	V _{EN} = 5V	EN	t _{s_n}	5	15	40	μs	A
10.6	Duty cycle 1	TH _{Rec(max)} = 0.744 × V _S TH _{Dom(max)} = 0.581 × V _S V _S = 7.0V to 18V t _{Bit} = 50μs D1 = t _{bus_rec(min)} / (2 × t _{Bit})	LIN	D1	0.396				A
10.7	Duty cycle 2	TH _{Rec(min)} = 0.422 × V _S TH _{Dom(min)} = 0.284 × V _S V _S = 7.6V to 18V t _{Bit} = 50μs D2 = t _{bus_rec(max)} / (2 × t _{Bit})	LIN	D2			0.581		A
10.8	Duty cycle 3	TH _{Rec(max)} = 0.778 × V _S TH _{Dom(max)} = 0.616 × V _S V _S = 7.0V to 18V t _{Bit} = 96μs D3 = t _{bus_rec(min)} / (2 × t _{Bit})	LIN	D3	0.417				A
10.9	Duty cycle 4	TH _{Rec(min)} = 0.389 × V _S TH _{Dom(min)} = 0.251 × V _S V _S = 7.6V to 18V t _{Bit} = 96μs D4 = t _{bus_rec(max)} / (2 × t _{Bit})	LIN	D4			0.590		A
10.10	Slope time falling and rising edge at LIN	V _S = 7.0V to 18V	LIN	t _{SLOPE_fall} t _{SLOPE_rise}	3.5		22.5	μs	A
11	Receiver Electrical AC Parameters of the LIN Physical Layer LIN Receiver, RXD Load Conditions: C _{RXD} = 20pF								
11.1	Propagation delay of receiver Figure 9-1	V _S = 7.0V to 18V t _{rx_pd} = max(t _{rx_pdr} , t _{rx_pdf})	RXD	t _{rx_pd}			6	μs	A
11.2	Symmetry of receiver propagation delay rising edge minus falling edge	V _S = 7.0V to 18V t _{rx_sym} = t _{rx_pdr} - t _{rx_pdf}	RXD	t _{rx_sym}	-2		+2	μs	A

*) Type means: A = 100% tested, B = 100% correlation tested, C = Characterized on samples, D = Design parameter

Figure 9-1. Definition of Bus Timing Characteristics

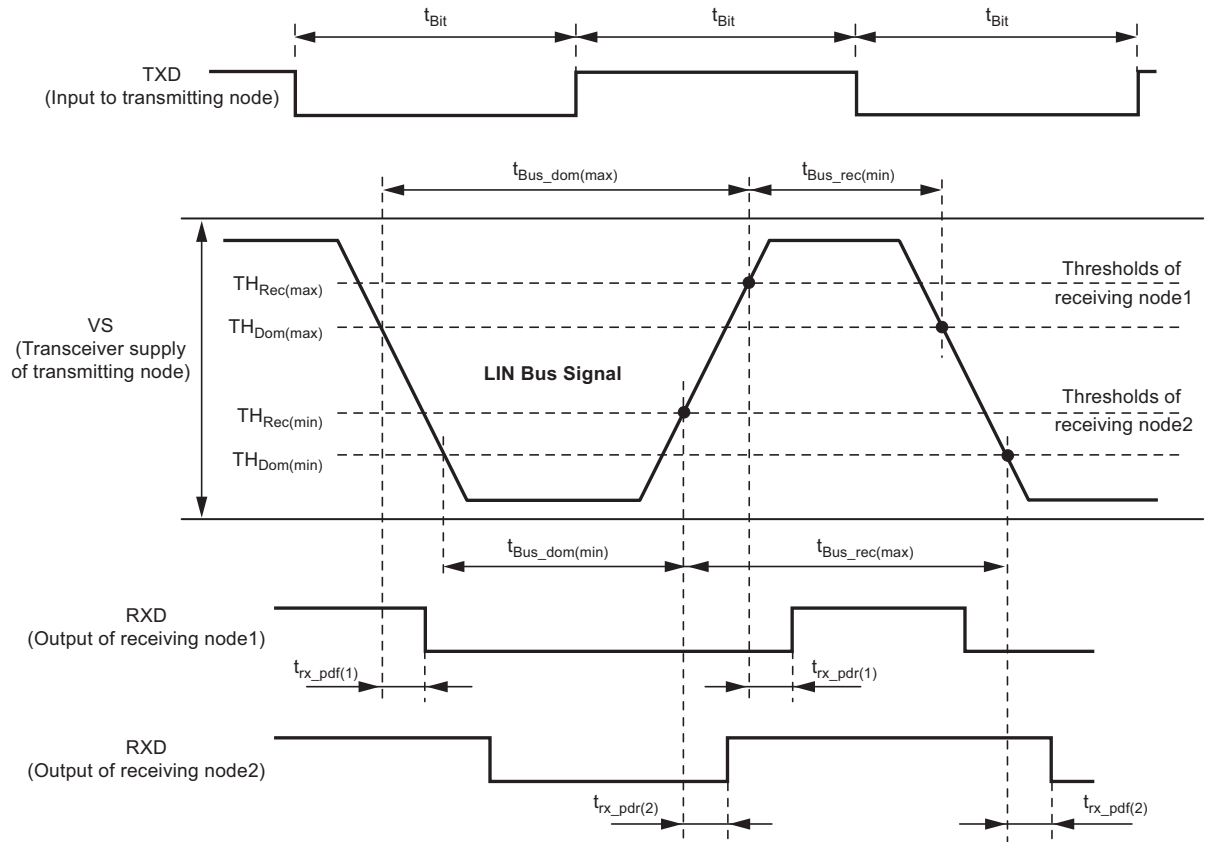
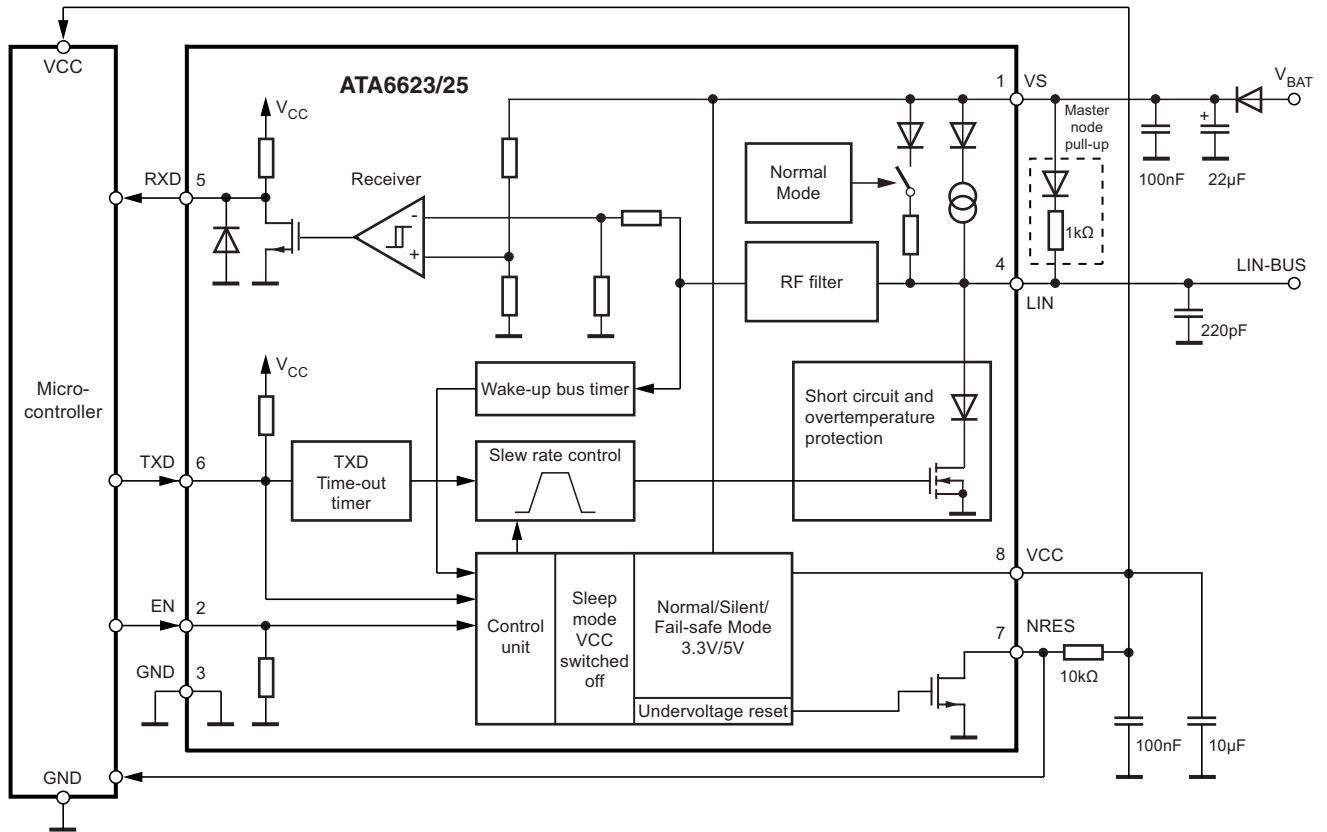

Figure 9-2. Application Circuit



10. Ordering Information

Extended Type Number	Package	Remarks
ATA6623C-GAQW	SO8	3.3V LIN system basis chip, Pb-free, 4k, taped and reeled
ATA6625C-GAQW	SO8	5V LIN system basis chip, Pb-free, 4k, taped and reeled

11. Package Information

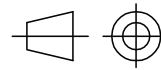
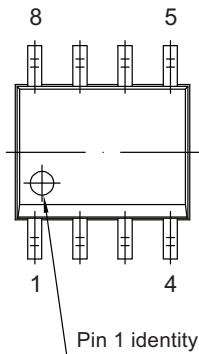
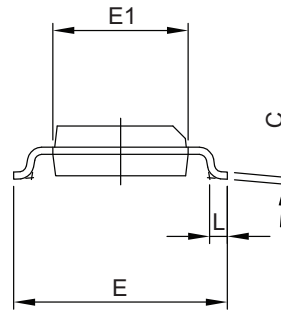
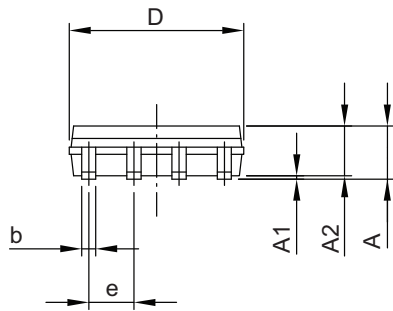

technical drawings
according to DIN
specifications

Dimensions in mm

COMMON DIMENSIONS				
(Unit of Measure = mm)				
Symbol	MIN	NOM	MAX	NOTE
A	1.5	1.65	1.8	
A1	0.1	0.15	0.25	
A2	1.4	1.47	1.55	
D	4.8	4.9	5	
E	5.8	6	6.2	
E1	3.8	3.9	4	
L	0.4	0.65	0.9	
C	0.15	0.2	0.25	
b	0.3	0.4	0.5	
e		1.27 BSC		

05/08/14

Atmel Package Drawing Contact:
packagedrawings@atmel.com

TITLE
Package: SO8

GPC

DRAWING NO.

REV.

6.543-5185.01-4

1

12. Revision History

Please note that the following page numbers referred to in this section refer to the specific revision mentioned, not to this document.

Revision No.	History
4957L-AUTO-09/14	<ul style="list-style-type: none"> Section 10 "Ordering Information" on page 20 updated
4957K-AUTO-02/13	<ul style="list-style-type: none"> Section 10 "Ordering Information" on page 20 updated
4957J-AUTO-11/12	<ul style="list-style-type: none"> Section 10 "Ordering Information" on page 20 updated
4957I-AUTO-03/11	<ul style="list-style-type: none"> Features on page 1 changed Section 1 "Description" on pages 1 to 2 changed Table 2-1 "Pin Description" on page 2 changed Section 3 "Functional Description" on pages 3 to 4 changed Section 4 "Modes of Operation" on pages 5 to 9 changed Section 6 "Voltage Regulator" on pages 11 to 12 changed Section 7 "Absolute Maximum Ratings" on page 13 changed Section 8 "Electrical Characteristics" on pages 14 to 16 changed
4957H-AUTO-05/10	<ul style="list-style-type: none"> New Part numbers ATA6623C and ATA6625C added Features on page 1 changed Text under heading 3.3 on page 3 changed Text under heading 3.9 on page 4 changed Abs.Max.Rat.Table -> Values in row "ESD HBM following...." changed El.Char.Table -> rows changed: 5.1, 5.2, 6.5, 6.6, 6.7, 6.8, 7.6, 7.7, 7.8,7.9, 10.2 El.Char.Table -> row 8.13 added Ord.Info.Table -> Part numbers ATA6623C and ATA6625C added
4957G-AUTO-09/09	<ul style="list-style-type: none"> Figures changed: 1-1, 4-2, 4-3, 4-4, 4-5, 6-2, 9-2 Sections changed: 3.1, 3.6, 3.8, 3.9, 3.10, 4.1, 4.2, 4.3, 5 Description Text changed Table 4-1 changed Abs. Max. Ratings table changed El. Characteristics table changed
4957F-AUTO-02/08	<ul style="list-style-type: none"> "Pre-normal Mode" in "Fail-safe Mode" changed Section 7 "Absolute Maximum Ratings" on page 13 changed Section 8 "Electrical Characteristics" numbers 10.5 to 10.10 on pages 17 to 18 changed
4957E-AUTO-10/07	<ul style="list-style-type: none"> Section 9 "Ordering Information" on page 20 changed
4957D-AUTO-07/07	<ul style="list-style-type: none"> Features changed Block diagram changed Application diagram changed Text changed under the headings: 3.2, 3.3, 3.4, 3.6, 3.7, 3.8, 3.9, 4, 4.1, 4.2, 4.3, 4.4, 4.5, 5.5, 5.6, 6 Figure 4-2, 4-3, 4-4, 4-5, 8-2: changed Figure title 6-1: text changed Abs. Max. Ratings: row "Output current NRES" added El. Char. table: values changed in the following rows: 1.3, 5.1, 5.3, 5.4, 6.9, 6.12, 7.9, 11.1



Atmel Corporation 1600 Technology Drive, San Jose, CA 95110 USA T: (+1)(408) 441.0311 F: (+1)(408) 436.4200 | www.atmel.com

© 2014 Atmel Corporation. / Rev.: Rev.: 4957L-AUTO-09/14

Atmel®, Atmel logo and combinations thereof, Enabling Unlimited Possibilities®, and others are registered trademarks or trademarks of Atmel Corporation in U.S. and other countries. Other terms and product names may be trademarks of others.

DISCLAIMER: The information in this document is provided in connection with Atmel products. No license, express or implied, by estoppel or otherwise, to any intellectual property right is granted by this document or in connection with the sale of Atmel products. EXCEPT AS SET FORTH IN THE ATMEL TERMS AND CONDITIONS OF SALES LOCATED ON THE ATMEL WEBSITE, ATMEL ASSUMES NO LIABILITY WHATSOEVER AND DISCLAIMS ANY EXPRESS, IMPLIED OR STATUTORY WARRANTY RELATING TO ITS PRODUCTS INCLUDING, BUT NOT LIMITED TO, THE IMPLIED WARRANTY OF MERCHANTABILITY, FITNESS FOR A PARTICULAR PURPOSE, OR NON-INFRINGEMENT. IN NO EVENT SHALL ATMEL BE LIABLE FOR ANY DIRECT, INDIRECT, CONSEQUENTIAL, PUNITIVE, SPECIAL OR INCIDENTAL DAMAGES (INCLUDING, WITHOUT LIMITATION, DAMAGES FOR LOSS AND PROFITS, BUSINESS INTERRUPTION, OR LOSS OF INFORMATION) ARISING OUT OF THE USE OR INABILITY TO USE THIS DOCUMENT, EVEN IF ATMEL HAS BEEN ADVISED OF THE POSSIBILITY OF SUCH DAMAGES. Atmel makes no representations or warranties with respect to the accuracy or completeness of the contents of this document and reserves the right to make changes to specifications and products descriptions at any time without notice. Atmel does not make any commitment to update the information contained herein. Unless specifically provided otherwise, Atmel products are not suitable for, and shall not be used in, automotive applications. Atmel products are not intended, authorized, or warranted for use as components in applications intended to support or sustain life.

SAFETY-CRITICAL, MILITARY, AND AUTOMOTIVE APPLICATIONS DISCLAIMER: Atmel products are not designed for and will not be used in connection with any applications where the failure of such products would reasonably be expected to result in significant personal injury or death ("Safety-Critical Applications") without an Atmel officer's specific written consent. Safety-Critical Applications include, without limitation, life support devices and systems, equipment or systems for the operation of nuclear facilities and weapons systems. Atmel products are not designed nor intended for use in military or aerospace applications or environments unless specifically designated by Atmel as military-grade. Atmel products are not designed nor intended for use in automotive applications unless specifically designated by Atmel as automotive-grade.

Mouser Electronics

Authorized Distributor

Click to View Pricing, Inventory, Delivery & Lifecycle Information:

[Microchip:](#)

[ATA6625C-TAQY](#) [ATA6623C-TAQY-19](#) [ATA6625C-GAQW](#) [ATA6623C-GAQW](#) [ATA6625GAQW](#)

Компания «Океан Электроники» предлагает заключение долгосрочных отношений при поставках импортных электронных компонентов на взаимовыгодных условиях!

Наши преимущества:

- Поставка оригинальных импортных электронных компонентов напрямую с производств Америки, Европы и Азии, а так же с крупнейших складов мира;
- Широкая линейка поставок активных и пассивных импортных электронных компонентов (более 30 млн. наименований);
- Поставка сложных, дефицитных, либо снятых с производства позиций;
- Оперативные сроки поставки под заказ (от 5 рабочих дней);
- Экспресс доставка в любую точку России;
- Помощь Конструкторского Отдела и консультации квалифицированных инженеров;
- Техническая поддержка проекта, помощь в подборе аналогов, поставка прототипов;
- Поставка электронных компонентов под контролем ВП;
- Система менеджмента качества сертифицирована по Международному стандарту ISO 9001;
- При необходимости вся продукция военного и аэрокосмического назначения проходит испытания и сертификацию в лаборатории (по согласованию с заказчиком);
- Поставка специализированных компонентов военного и аэрокосмического уровня качества (Xilinx, Altera, Analog Devices, Intersil, Interpoint, Microsemi, Actel, Aeroflex, Peregrine, VPT, Syfer, Eurofarad, Texas Instruments, MS Kennedy, Miteq, Cobham, E2V, MA-COM, Hittite, Mini-Circuits, General Dynamics и др.);

Компания «Океан Электроники» является официальным дистрибьютором и эксклюзивным представителем в России одного из крупнейших производителей разъемов военного и аэрокосмического назначения «JONHON», а так же официальным дистрибьютором и эксклюзивным представителем в России производителя высокотехнологичных и надежных решений для передачи СВЧ сигналов «FORSTAR».



JONHON

«JONHON» (основан в 1970 г.)

Разъемы специального, военного и аэрокосмического назначения:

(Применяются в военной, авиационной, аэрокосмической, морской, железнодорожной, горно- и нефтедобывающей отраслях промышленности)

«FORSTAR» (основан в 1998 г.)

ВЧ соединители, коаксиальные кабели, кабельные сборки и микроволновые компоненты:

(Применяются в телекоммуникациях гражданского и специального назначения, в средствах связи, РЛС, а так же военной, авиационной и аэрокосмической отраслях промышленности).



Телефон: 8 (812) 309-75-97 (многоканальный)

Факс: 8 (812) 320-03-32

Электронная почта: ocean@oceanchips.ru

Web: <http://oceanchips.ru/>

Адрес: 198099, г. Санкт-Петербург, ул. Калинина, д. 2, корп. 4, лит. А