

Interface Connector for Railway Applications

TJ*A Series

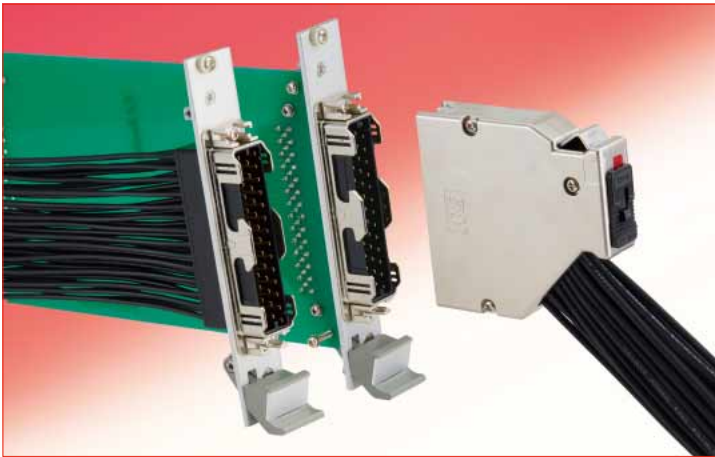

One touch locking design provides a clear tactile click and simplified operations.

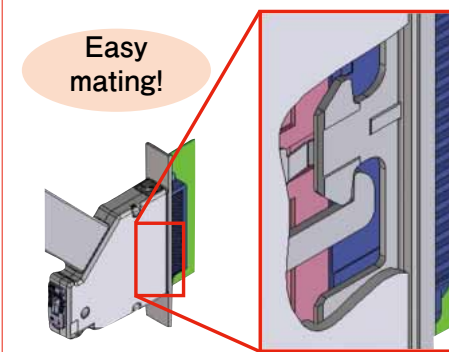

Fig.1

■ General

TJ*A series interface connectors for railway car stock applications. It can be attached to 3U4HP size panels for VME rack or Compact PCI rack. PCB mount type and in-line type are available. Suitable for use with 16 to 22AWG wire.

■ Features

1. One-Touch Locking system

A one-touch locking structure that delivers a simple, user friendly operation and emits a clear tactile upon completion. (Fig.1)

2. Lock Hold Slide Button

Our proprietary slide lock design prevents inadvertent unlocking. The slide lock can be visually inspected to ensure lock engagement. (Fig.2)

3. Pressed Contacts

The TJ*A series use a pressed style contact. Two points of contact are achieved by a spring contact portion and non-spring contact portion. This realizes space saving and high reliability. The contact has been designed with tapers to prevent buckling. Suitable for (16 to 22AWG) wire. (Fig.3)

4. Two different cable outlet options

There are two directions available for the cable outlets, 45 degree upward or downward.

5. Aluminum Die Cast Cover

Aluminum was selected for the plug side cover due to its lightweight and EMI performance.

6. Rugged Structure

The PCB type receptacle is designed with screw locations that allow it to be secured to the PCB or panel. This feature prevents insertion and extraction stress delivered to the soldered area. (PCB-mount type only.)

7. Contact Protection

Surrounding structure protects the contacts from possible dust attachment fallen from the top of the plug during insertion and extraction for system maintenance.

8. Flexibility and options of our coding key system

Our die cast coding key system offers up to 100 combinations and allows you to use multiple connectors without the danger of miss-mating.

The slide lock is designed to prevent inadvertent unlocking.

■ Slide Lock Unlocked

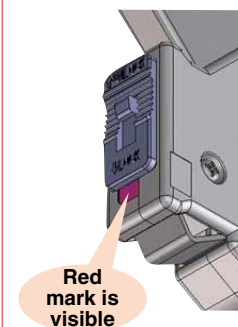

Red mark is visible



Lever operation is available

■ Slide Lock Locked

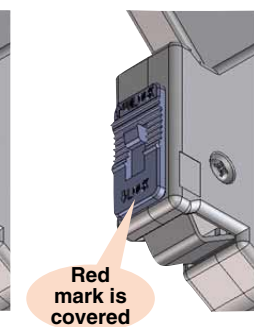

Red mark is covered



Lever operation is inaccessible

Fig.2

Press contact-pin with sufficient mating guide
The 2 point contact structure

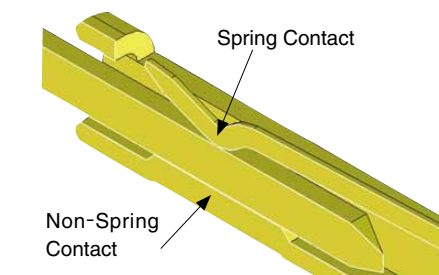

Taper for easy mating

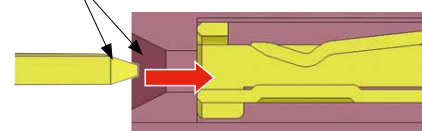

Sufficient mating guide

Fig.3

Product Specifications

Ratings	Voltage	AC/DC 30V, 130V		Op. Temp. Range	-40 to +105°C (Note 2)
	Current	4A/pin (Note 1)	With HF-WV0 1.25 sq (16AWG)	Stor. Temp. Range	-55 to +85°C (Note 3)

Items	Specifications	Conditions
1. Contact resistance	10mΩ max (Note 4)	Measured at 100mA
2. Insulation resistance	Minimum of 5,000MΩ	Measured at DC 500V
3. Withstand voltage	No flashover or breakdown	Apply AC 1,260 V for 1 minute
4. Durability	Contact resistance : Increase by 20mΩ or less from the initial value	500 mating cycles
5. Vibration resistance	1) No electric outage of 10μs or more 2) No breakage, cracks or loosened parts	JIS E 4031, Section 1, Grade B Freq. range : 5-150Hz, Vib. cond. rms : 7.9m/s ² Test for 5 hours each for 3 axial directions
6. Shock resistance		JIS E 4031, Section 1, Grade B Acceleration 50m/s ² , duration 30 ms, half-sine wave, test 3 times each for 3 axial directions
7. Temperature cycles	1) Change of contact resistance : 20mΩ max 2) No breakage, cracks or loose parts.	Temperature : -40 → +15 to +35 → +105 → +15 to +35°C Time : 30 → 2 to 3 → 30 → 2 to 3 min Repeat 5 cycles of the above.
8. Moisture-resistance	1) Change of contact resistance : 20mΩ max 2) Insulation resistance : minimum of 1,000MΩ (after drying) 3) No breakage, cracks or loose parts	Leave in temperature 60 ±2°C, humidity 95% for 96 hours. (in mated condition)

Note 1 : Depending on PCB design and cables used.

Note 2 : Includes temperature rise caused by current flow.

Note 3 : Packing materials not included. Operating temperature range is applied to storage conditions after mounting the product.

Note 4 : Excluding conductor resistance of the cable.

Materials / Finish

●Receptacle (PCB type)

Parts	Materials	Color/Finish	Remarks
Insulator	PBT resin	Black	UL94V-0
Contact	Copper alloy	Partially gold plated	-
Insert nut	Copper alloy	Nickel plating	-
Shell	Zinc alloy	Nickel plating	-

●Receptacle (in-line type)

Parts	Materials	Color/Finish	Remarks
Insulator	PBT resin	Black	UL94V-0
Insert nut	Copper alloy	Nickel plating	-
Shell	Zinc alloy	Nickel plating	-

●Plug

Parts	Materials	Color/Finish	Remarks
Insulator	PBT resin	Black	UL94V-0
Cover case	Aluminum alloy	Chrome plating over Nickel under plating	-
Ground contact	Phosphorous Bronze	Nickel plating	-
Lever	Stainless steel	-	-
Spring	Stainless steel	-	-
Retention plate	Stainless steel	-	-
Clamp metal	Steel	Nickel plating	-
Screw	Steel	Nickel plating	-

●Crimp Contact

Parts	Materials	Color/Finish	Remarks
Crimp contact	Copper alloy	Contact area: Gold plating Barrel area: Tin plating	-

●Coding Key System

Parts	Materials	Color/Finish	Remarks
Coding key system	Zinc alloy	Nickel plating	-
Screw	Steel	Nickel plating	-

●Cap

Parts	Materials	Color/Finish	Remarks
Cap	PC resin	Black	UL94V-0

Product Number Structure

Refer to the chart below when determining the product specifications from the product number.
Please select from the product numbers listed in this catalog when placing orders.

●Receptacle (PCB type)

TJ 10 A - 41 P ()**
1 2 1 3 4 11

●Crimp Contact

TJ 50 A - 1618 SC F A - A ()**
1 2 1 7 8 9 10 11 12

●Receptacle (in-line type)

TJ 50 A - 41 P
1 2 1 3 4

●Coding Key System

TJ - KY - PA
1 4 13

●Plug

TJ 50 A - 41 S - U - CV
1 2 1 3 4 5 6

●Cap

TJA - P - DC
1 4 14

1 Series name		TJ*A
2 Wiring style	10	Right angle DIP
	50	Crimp type
3 No. of contacts	28	28 contacts
	41	41 contacts
4 Connector type	P	Receptacle connector (male contacts)
	S	Plug connector (female contacts)
	KY	Coding key system
5 Cable outlet direction	U	45 degrees upward
	D	45 degrees downward
6 Clamp metal type	CV	Standard
	CV1	For cable tie fixing
7 Applicable cable type	1618	0.75~1.25SQ (16 to 18AWG)
	2022	0.3~0.5SQ (20 to 22AWG)
8 Contact type	PC	Crimp contact for receptacle (male contact)
	SC	Crimp contact for plug (female contact)
9 Delivery form (Note 1)	None	Loose piece contacts (100 pcs/pack)
	F	Reel contacts (4,000 pcs/reel)
10 Contact plating type	A	Contact area : Gold plating
11 Serial number	None	Standard
	A	For thin cable insulation
12 Special specifications	None	Contact area : Gold plating thickness 0.76μm
13 Key type (Note 2)	P*	Male side key (5 types of PA, PB, PC, PD and PE)
	S*	Female side key (5 types of SA, SB, SC, SD and SE)
14 Cap	DC	Cap

Note 1 : If the manual crimp tool is used, make sure you select the loose piece contacts.

Note 2 : All types are compatible regardless of the receptacle or plug.

Make sure that the P (male) and S (female) are paired together, such as the TJ-KY-PA for the receptacle and the TJ-KY-SA for the plug.

Functional Diagram

●Coding Key System [TJ-KY-**]

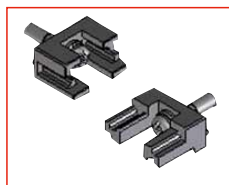

●Receptacle (PCB type) [TJ10A-**P]

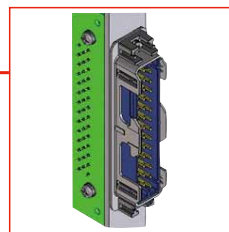

●Plug (upward facing cable outlet) [TJ50A-41S-U-CV]

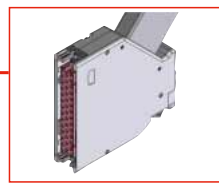

●Coding Key System [TJ-KY-**]

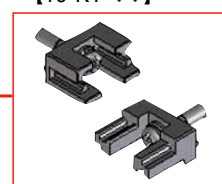

●Cap



●Receptacle (in-line type) [TJ50A-41P]

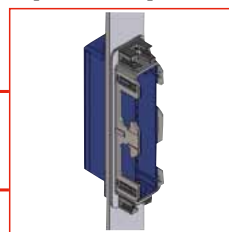

●Plug (downward facing cable outlet) [TJ50A-41S-D-CV]

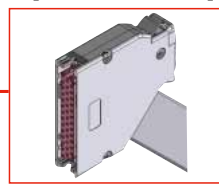

●Crimp Contact (female) [TJ50A-****SC*A]

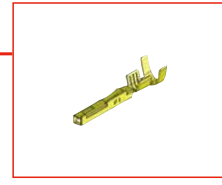

●Crimp Contact (male) [TJ50A-****PC*A]



■Receptacle (PCB type)

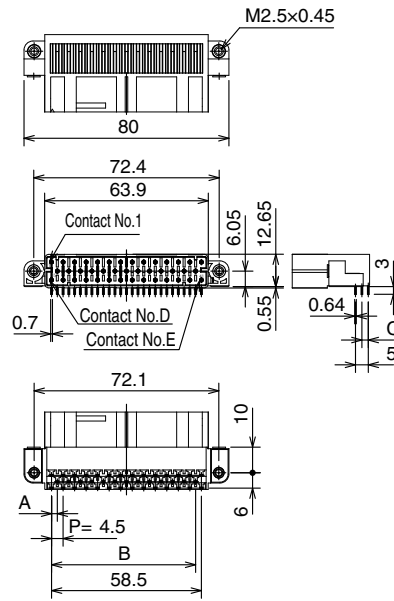

■Attachment

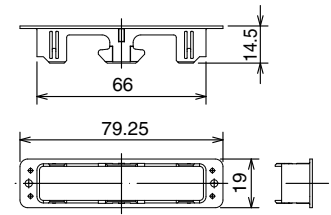

Part No.	HRS No.	A	B	C	D	E (No. of Contacts)	Remarks
TJ10A-28P	236-3118-3 00	-	-	-	15	28	Contact area : Gold plating 0.76μm
TJ10A-41P	236-3100-8 00	2.25	56.25	2.5	28	41	

Note : PCB securing screws are not included with this product.

■Receptacle (in-line type)

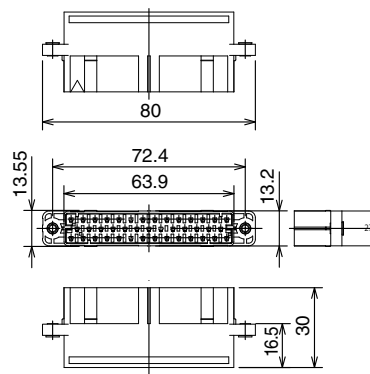
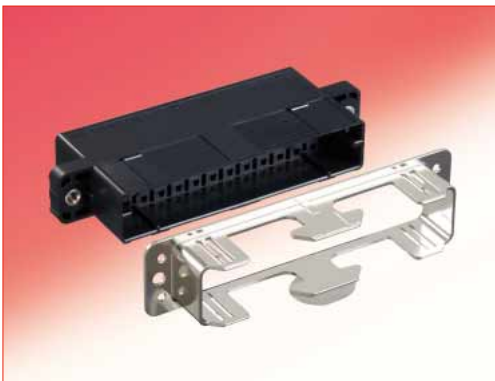

■Attachment

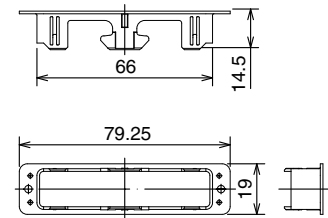

Part No.	HRS No.	No. of Contacts	Remarks
TJ50A-41P	236-3117-0 00	41	-

■ Plug

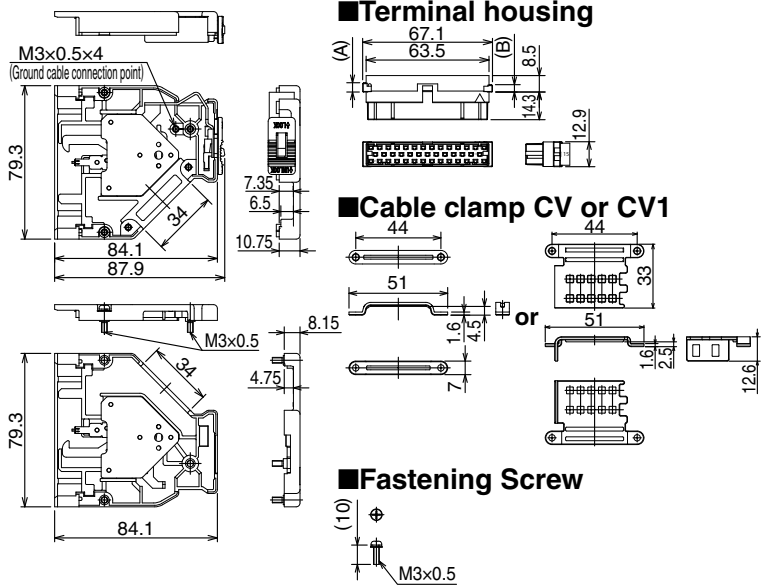

Part No.	HRS No.	A	B	No. of Contacts	Remarks
TJ50A-41S-U-CV	236-3101-0 00	4.8	3.8	41	Cable outlet direction : 45 deg. upward, clamp metal CV
TJ50A-41S-U-CV(01)	236-3101-0 01	4.8	3.8	41	Only insulator U
TJ50A-41S-U-CV(02)	236-3101-0 02	-	-	-	Only clamp metal CV
TJ50A-41S-D-CV	236-3102-3 00	3.8	4.8	41	Cable outlet direction : 45 deg. downward, clamp metal CV
TJ50A-41S-D-CV(01)	236-3102-3 01	3.8	4.8	41	Only insulator D
TJ50A-41S-U-CV1	236-3119-6 00	4.8	3.8	41	Cable outlet direction : 45 deg. upward, clamp metal CV1
TJ50A-41S-U-CV1(02)	236-3119-6 02	-	-	-	Only clamp metal CV1
TJ50A-41S-D-CV1	236-3120-5 00	3.8	4.8	41	Cable outlet direction : 45 deg. downward, clamp metal CV1

■ Coding Key System

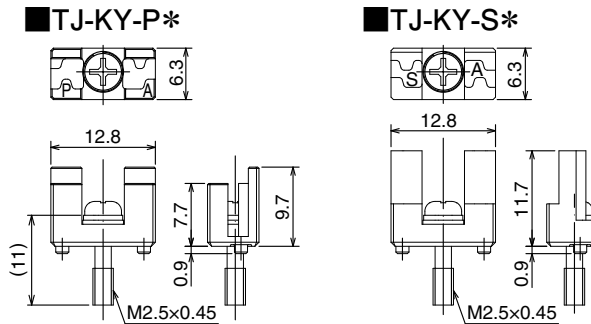

Part No.	HRS No.	Remarks
TJ-KY-PA	236-3107-7	50 pcs/pack
TJ-KY-PB	236-3108-0	
TJ-KY-PC	236-3109-2	
TJ-KY-PD	236-3110-1	
TJ-KY-PE	236-3111-4	
TJ-KY-SA	236-3112-7	
TJ-KY-SB	236-3113-0	
TJ-KY-SC	236-3114-2	
TJ-KY-SD	236-3115-5	
TJ-KY-SE	236-3116-8	

■ Cap

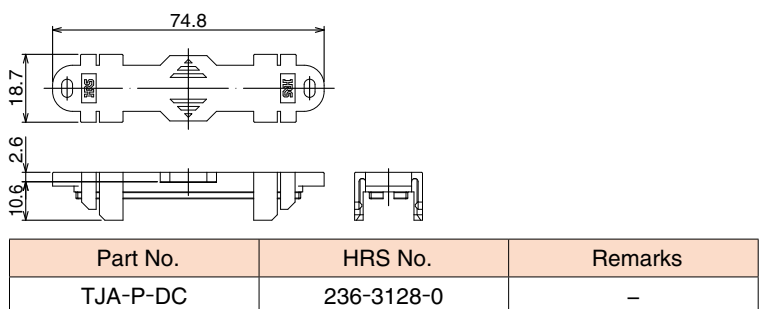
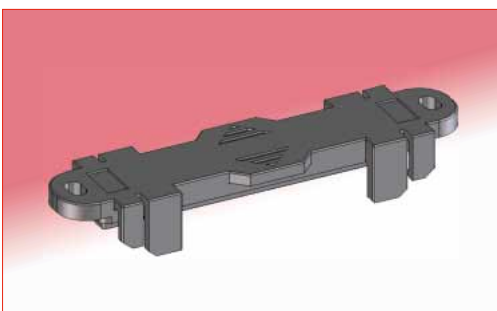

■ Crimp Contact (female)

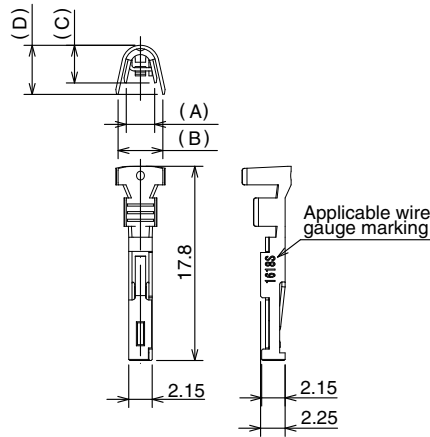

Part No.	HRS No.	A	B	C	D	Remarks
TJ50A-1618SCA	236-3103-6	2.6	4.1	3.45	4.5	Contact area : Gold 0.76 μm discrete contacts (100 pcs/pack)
TJ50A-2022SCA	236-3104-9	1.9	3.3	2.7	3.35	
TJ50A-1618SCFA	Not developed yet. Please call us.	2.6	4.1	3.45	4.5	Contact area : Gold 0.76 μm end-to-end contacts (4,000 pcs/reel)
TJ50A-2022SCFA		1.9	3.3	2.7	3.35	
TJ50A-1618SCA-A	236-3122-0	2.6	2.9	3.45	2.9	Contact area : Gold 0.76 μm discrete contacts (100 pcs/pack)
TJ50A-2022SCA-A	236-3123-0	1.9	2.4	2.7	1.94	

■ Crimp Contact (male)

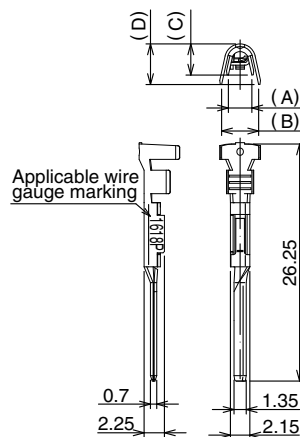

Part No.	HRS No.	A	B	C	D	Remarks
TJ50A-1618PCA	236-3105-1	2.6	4.1	3.45	4.5	Contact area : Gold 0.76 μm discrete contacts (100 pcs/pack)
TJ50A-2022PCA	236-3106-4	1.9	3.3	2.7	3.35	
TJ50A-1618PCFA	Not developed yet. Please call us.	2.6	4.1	3.45	4.5	Contact area : Gold 0.76 μm end-to-end contacts (4,000 pcs/reel)
TJ50A-2022PCFA		1.9	3.3	2.7	3.35	

◆ Manual Crimp Tools

Tool Frame	* Die set Upper row : Part No. Lower row : HRS No.	Applicable Contacts	Applicable Cables		
			Maker	Part No.	Nominal Cross Section mm ²
HT702 [250-1001-1]	TJ50A-1618-A [250-1023-4]	TJ50A-1618PCA TJ50A-1618SCA	Hitachi Metals, Ltd.	HF-WV0	1.25
				NH-WEX0	0.75
	TJ50A-2022-A [250-1024-7]	TJ50A-2022PCA TJ50A-2022SCA		NH-WEX0	0.5
	TJ50A-17-A [250-1033-0]	TJ50A-1618SCA-A	HUBER+SUHNER	RADOX TENUIS-TW	1
	TJ50A-18-A [250-1034-0]				0.75
	TJ50A-20-A [250-1035-0]	TJ50A-2022SCA-A			0.5

* Note : Part numbers listed above are for complete die sets. Spare or replacement parts are on page 7.

Manual Crimp Tools

The Hirose hand tool for the TJ*A series features replaceable die sets and parts. This allows you the ability to use one Hirose tool body and switch between the two Hirose die sets to crimp either of the TJ*A terminals.

Due to wear, neglect or loss, replacement parts are also available for the Hirose die sets. Please see the chart at the bottom of page seven for these part numbers. Please be careful to select the correct replacement part based on the terminal and wire size you are trying to crimp. If you have any concern on the correct part to purchase, a Hirose sales representative will be glad to assist in selecting the correct part.

*Please refer to the bottom of page 6 and 7 for product numbers and descriptions.

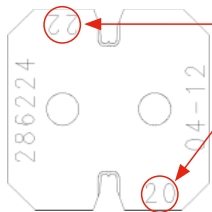
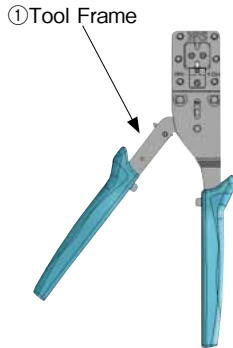

The wire crimper and insulation crimper are wire gauge specific. Each crimping location is marked on the part. Please make sure that you have each crimper orientated to the specific wire gauge you are using.

Part No.	HRS No.
HT702	250-1001-1 00

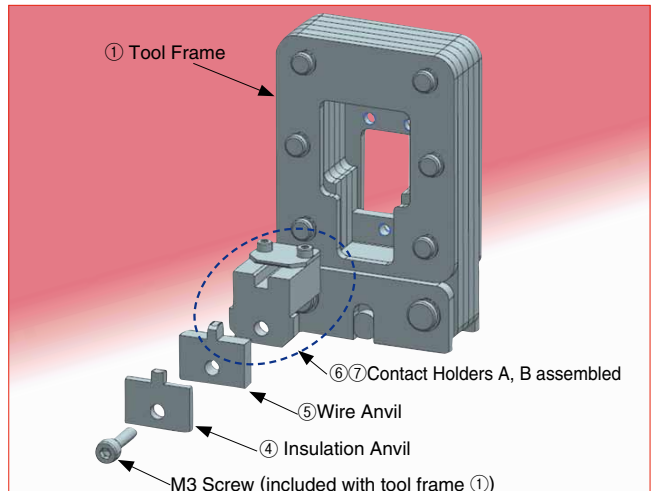
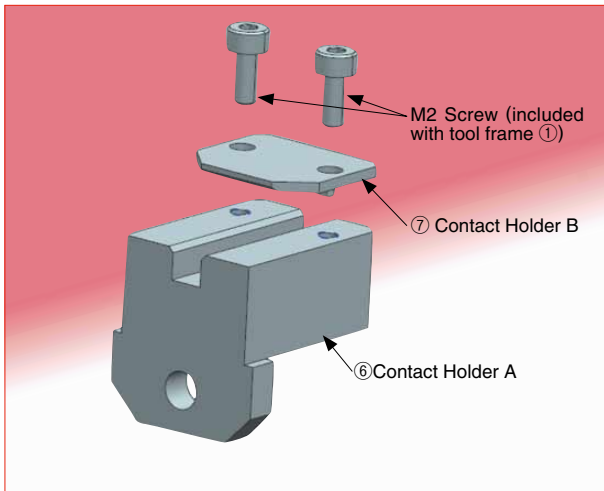
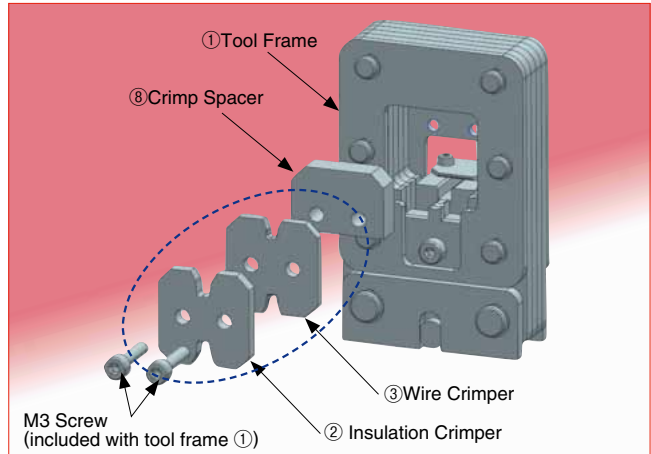

Automatic Crimper

Please call us.

Extraction tools

Part No.	HRS No.	Remarks
PQ50S/RE-MD	902-2202-2 00	1 pcs/box

Upper row : Product No. / Lower row : HRS No.						
② IC Insulation Crimper	③ WC (Wire Crimper)	④ IA (Insulation Anvil)	⑤ WA (Wire Anvil)	⑥ Contact Holder A	⑦ Contact Holder B	⑧ Crimper Spacer
286648 [250-1023-4(61)]	286649 [250-1023-4(62)]	286650 [250-1023-4(63)]	286651 [250-1023-4(64)]	286652 [250-1023-4(65)]	286653 [250-1023-4(66)]	285996 [250-1023-4(67)]
286654 [250-1024-7(61)]	286655 [250-1024-7(62)]	286656 [250-1024-7(63)]	286657 [250-1024-7(64)]	286652 [250-1024-7(65)]	286653 [250-1024-7(66)]	285996 [250-1024-7(67)]
287347 [250-1033-0(61)]	286960 [250-1033-0(62)]	287343 [250-1033-0(63)]	286651 [250-1033-0(64)]	286652 [250-1033-0(65)]	286653 [250-1033-0(66)]	285996 [250-1033-0(67)]
287342 [250-1034-0(61)]	286649 [250-1034-0(62)]	287343 [250-1034-0(63)]	286651 [250-1034-0(64)]	286652 [250-1034-0(65)]	286653 [250-1034-0(66)]	285996 [250-1034-0(67)]
287344 [250-1035-0(61)]	286655 [250-1035-0(62)]	287345 [250-1035-0(63)]	286657 [250-1035-0(64)]	286652 [250-1035-0(65)]	286653 [250-1035-0(66)]	285996 [250-1035-0(67)]

* Note : Part numbers listed above are for component parts needed for repair or service. Part numbers for complete die sets can be found on page 6.

Recommended PCB layout Dimensions

(PCB thickness : t= 1.6mm)

TJ10A-**P

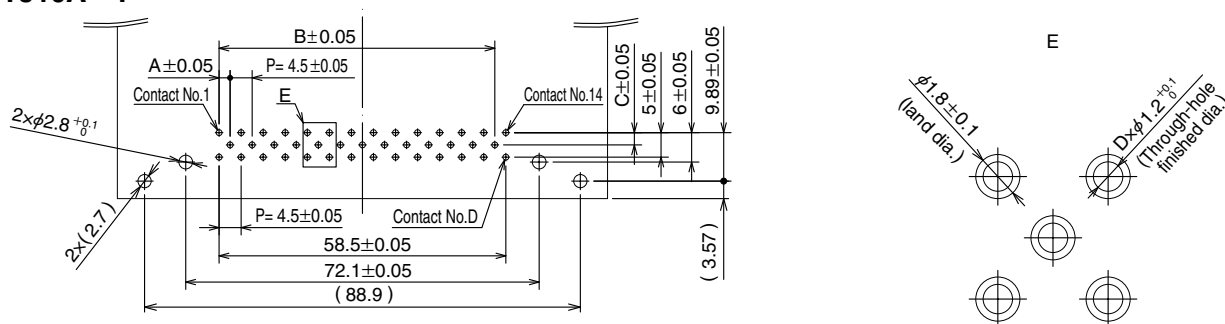

Part No.	A	B	C	D
TJ10A-28P	-	-	-	28
TJ10A-41P	2.25	56.25	2.5	41

For dimensions in "()", apply dimensions of Euroboard standards.

Recommended Panel Dimensions

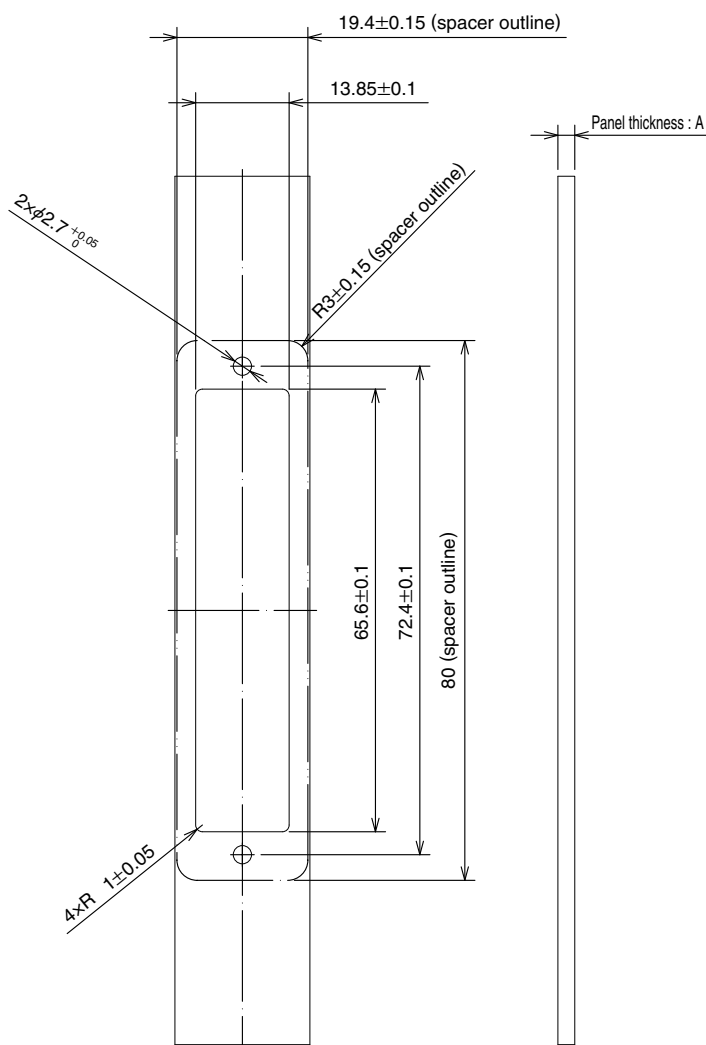

Part No.	Panel thickness : A
TJ10A-28P	2.5±0.1
TJ10A-41P	
TJ50A-41P	2.5 +0.7/-0.2

Note 1 : If the panel thickness is less than what was described above, then spacers can be used to adjust the panel thickness.

Note 2 : If conditions exist where EMC/EMI is required, apply a conductive surface treatment such as a non-chromate treatment to the panel surface.



HIROSE ELECTRIC CO.,LTD.

2-6-3,Nakagawa Chuoh,Tsuzuki-Ku,Yokohama-Shi 224-8540,JAPAN
 TEL: +81-45-620-3526 Fax: +81-45-591-3726
<http://www.hirose.com>
<http://www.hirose-connectors.com>

Компания «Океан Электроники» предлагает заключение долгосрочных отношений при поставках импортных электронных компонентов на взаимовыгодных условиях!

Наши преимущества:

- Поставка оригинальных импортных электронных компонентов напрямую с производств Америки, Европы и Азии, а так же с крупнейших складов мира;
- Широкая линейка поставок активных и пассивных импортных электронных компонентов (более 30 млн. наименований);
- Поставка сложных, дефицитных, либо снятых с производства позиций;
- Оперативные сроки поставки под заказ (от 5 рабочих дней);
- Экспресс доставка в любую точку России;
- Помощь Конструкторского Отдела и консультации квалифицированных инженеров;
- Техническая поддержка проекта, помощь в подборе аналогов, поставка прототипов;
- Поставка электронных компонентов под контролем ВП;
- Система менеджмента качества сертифицирована по Международному стандарту ISO 9001;
- При необходимости вся продукция военного и аэрокосмического назначения проходит испытания и сертификацию в лаборатории (по согласованию с заказчиком);
- Поставка специализированных компонентов военного и аэрокосмического уровня качества (Xilinx, Altera, Analog Devices, Intersil, Interpoint, Microsemi, Actel, Aeroflex, Peregrine, VPT, Syfer, Eurofarad, Texas Instruments, MS Kennedy, Miteq, Cobham, E2V, MA-COM, Hittite, Mini-Circuits, General Dynamics и др.);

Компания «Океан Электроники» является официальным дистрибьютором и эксклюзивным представителем в России одного из крупнейших производителей разъемов военного и аэрокосмического назначения «JONHON», а так же официальным дистрибьютором и эксклюзивным представителем в России производителя высокотехнологичных и надежных решений для передачи СВЧ сигналов «FORSTAR».



JONHON

«JONHON» (основан в 1970 г.)

Разъемы специального, военного и аэрокосмического назначения:

(Применяются в военной, авиационной, аэрокосмической, морской, железнодорожной, горно- и нефтедобывающей отраслях промышленности)

«FORSTAR» (основан в 1998 г.)

ВЧ соединители, коаксиальные кабели,
кабельные сборки и микроволновые компоненты:

(Применяются в телекоммуникациях гражданского и специального назначения, в средствах связи, РЛС, а так же военной, авиационной и аэрокосмической отраслях промышленности).



Телефон: 8 (812) 309-75-97 (многоканальный)

Факс: 8 (812) 320-03-32

Электронная почта: ocean@oceanchips.ru

Web: <http://oceanchips.ru/>

Адрес: 198099, г. Санкт-Петербург, ул. Калинина, д. 2, корп. 4, лит. А