



Piezo Haptic Actuators - PowerHap

Actuators with Adjustable Haptic Feedback

Series/Type: 6005H070V120, prototype
Ordering code: Z63000Z2910Z 1Z42
Date: 2019-04-17
Version: 7

Preliminary data
Features

- Large displacement
- High acceleration
- High force
- Fast response time
- Integrated sensor functionality

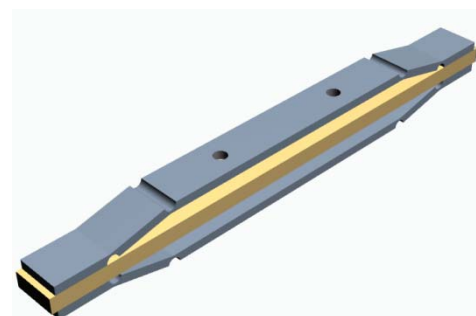
Design

- RoHS-compatible PZT (lead zirconium titanate) ceramic
- Copper inner electrodes
- Dimension of ceramic body: 5 x 60 x 1.8 (mm)
- Dimension of actuator: 5 x 60 x 7 (mm)
- Titanium bows for displacement amplification
- Previously known as PowerHap™ 20G
- Contains SVHC substance 12626-81-2

General technical data

| Parameter | Ratings |
|---------------------------------------|---|
| Operating voltage range | -20 ... 120 V |
| Operating temperature powered | -40 ... +85 °C |
| Operating temperature unpowered | -40 ... +125 °C |
| Maximum compressive force on actuator | 50 N |
| Maximum operation frequency | operation frequency is limited by self-heating of the device. The self-heating of device should not exceed by +30 °C. At 120 V, 500 Hz, square wave conditions, a maximum allowable temperature increase of +30 °C is observed after about 10 s of operation. |
| Maximum voltage gradient | 1.2 MV/s |

Electrical characteristics at 25 °C

| Parameter | Conditions | Expected value (typ.) |
|----------------|---|-----------------------|
| Capacitance | C 1 kHz, 1 V _{RMS} | 3.4 µF |
| Displacement | s 0 ... 120 V, measured at middle of Ti-bows | 280 µm |
| Loading charge | Q 0 ... 120 V | 0.5 mC |

Preliminary data
Further typical electrical characteristics as a design reference for haptic applications at 25 °C¹⁾

| Parameter | | Conditions | Typical |
|--|---|---|--|
| Stiffness | k | 120 V various load stiffness; preload 20 N | 90 N/mm |
| Acceleration unipolar ²⁾ (see fig. 5.) | a | 100 g, single pulse sine wave, 200 Hz, 0...120 V | 75 · g (peak to peak) 36 · g (peak) |
| | | 500 g, single pulse sine wave, 200 Hz, 0...120 V | 13 · g (peak to peak) 6 · g (peak) |
| | | 1000 g, single pulse sine wave, 200 Hz, 0...120 V | 4 · g (peak to peak) 2 · g (peak) |
| Acceleration bipolar ²⁾ (see fig. 6.) | a | 20 g, single pulse sine wave, 200 Hz, -20...20 V | 40 · g (peak to peak) 20 · g (peak) |
| | | 100 g, single pulse sine wave, 200 Hz, -20...20 V | 23 · g (peak to peak) 11 · g (peak) |

¹⁾ Characterization performed with the support of AddHaptics Inc.

²⁾ g is unit of measure of acceleration. 1 g is the acceleration due to gravity at the earth's surface $1 \cdot g = 9.81 \text{ m/s}^2$.

Preliminary data

Dimensional drawings

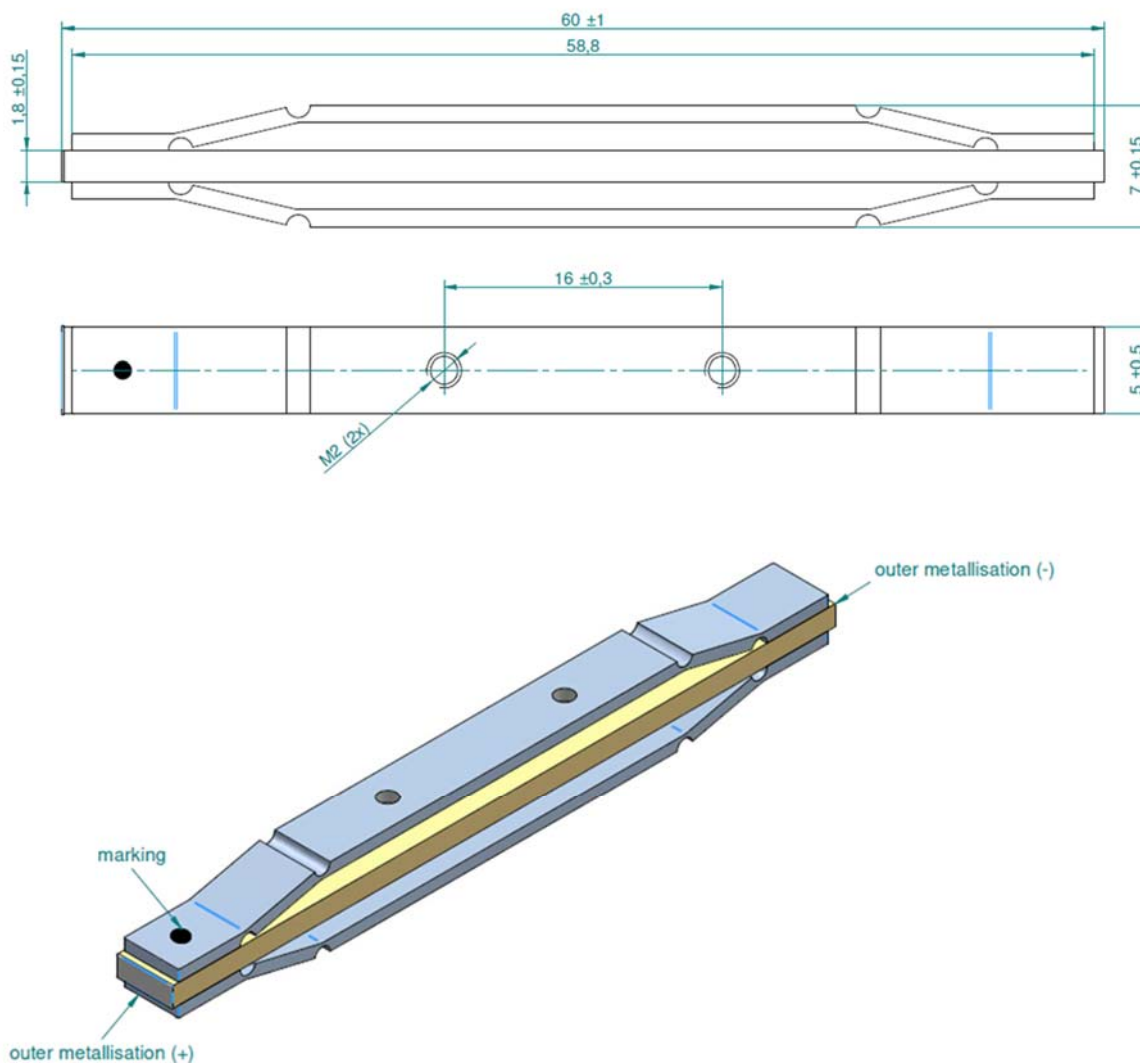

Fig.1: Dimensional drawing.

Polarity of the prototypes: In the preliminary phase, samples are delivered with soldered wires where red wire is the positive pole.

Preliminary data

Typical characteristics of PowerHap 6005H070V120 as a design reference for haptic applications

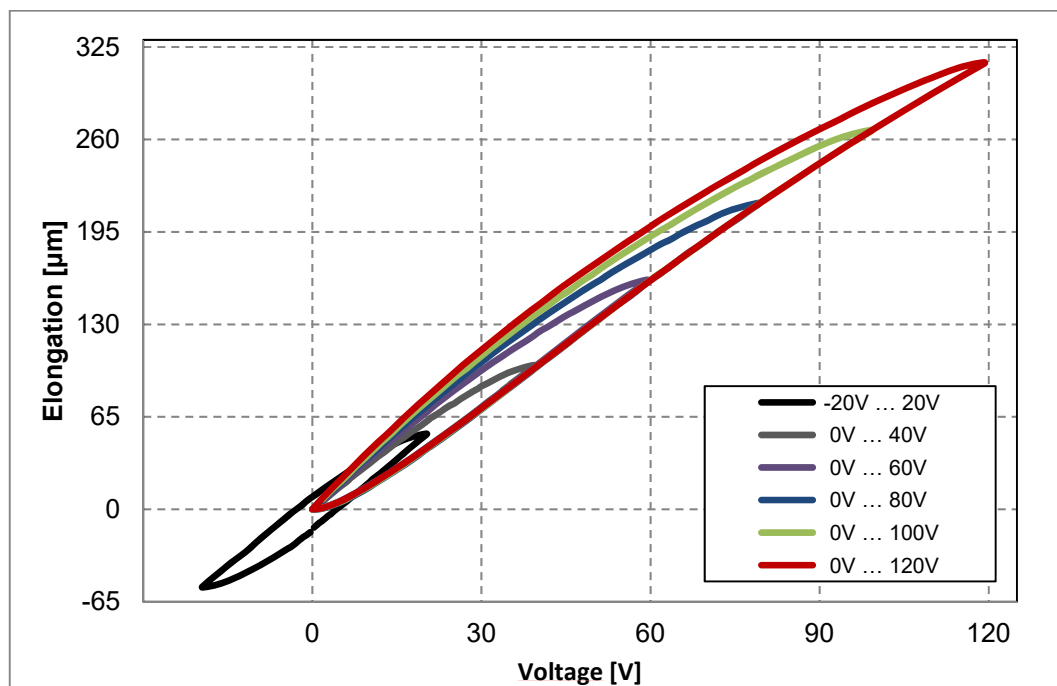

Fig. 2: Elongation measured between bow end-caps as a function of voltage.

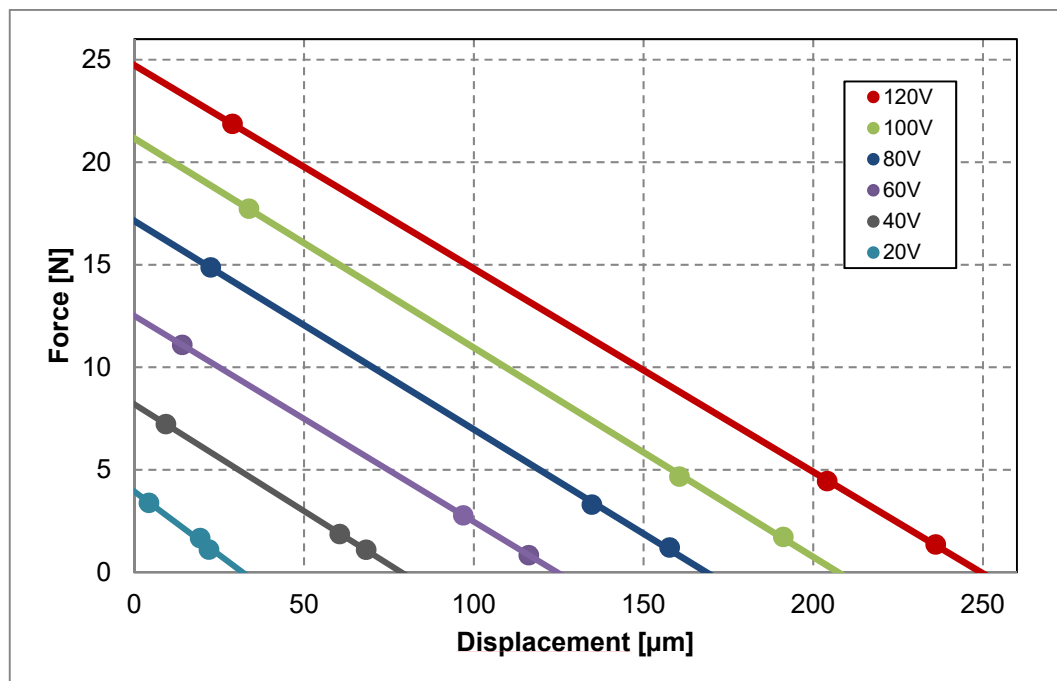

Fig. 3: Force-stroke diagram with different load springs preload 20 N. Typical stiffness 100 N/mm.

Preliminary data

Acceleration measurement on test set up

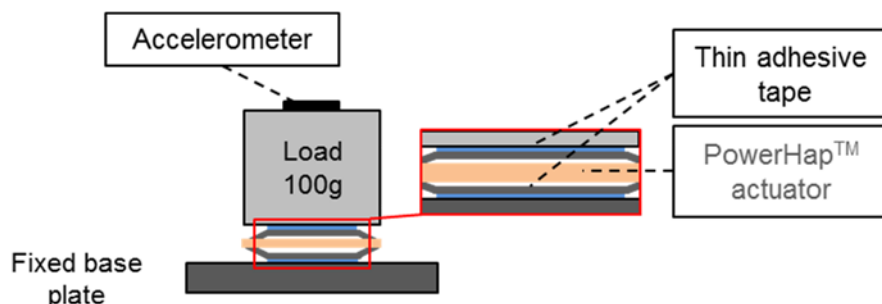

Fig. 4: Measurement setup for acceleration.

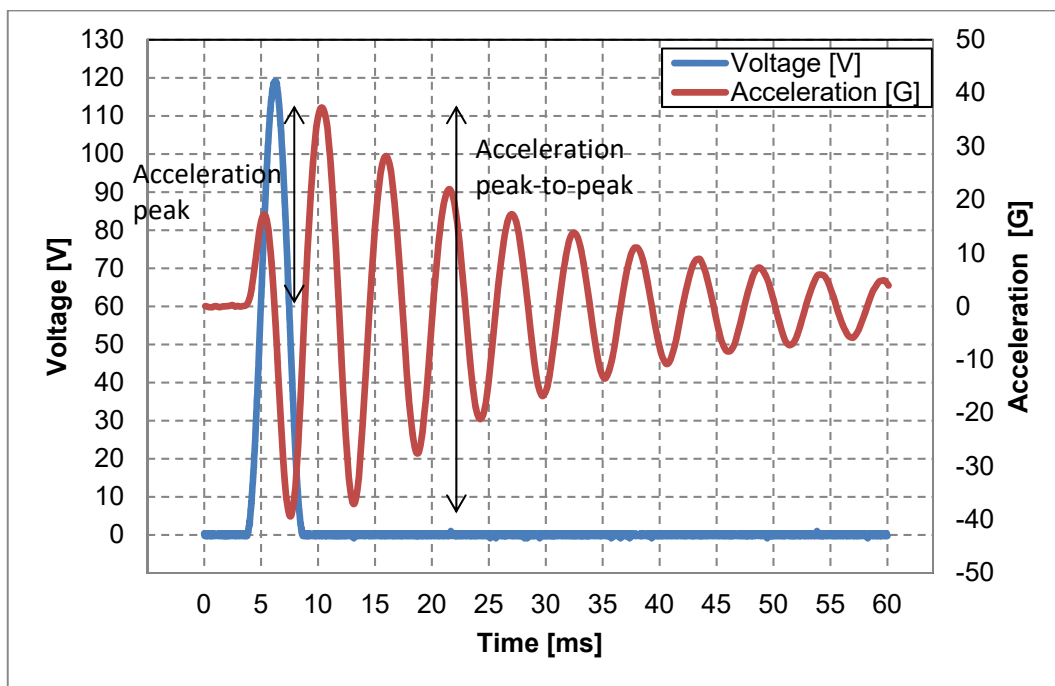

Fig. 5: Typical acceleration as a function of input voltage with 100 g load. Input voltage with a half wave sinus signal form of amplitude 0 ... 120 V and pulse length 5 ms which is equivalent to 200 Hz.

Preliminary data

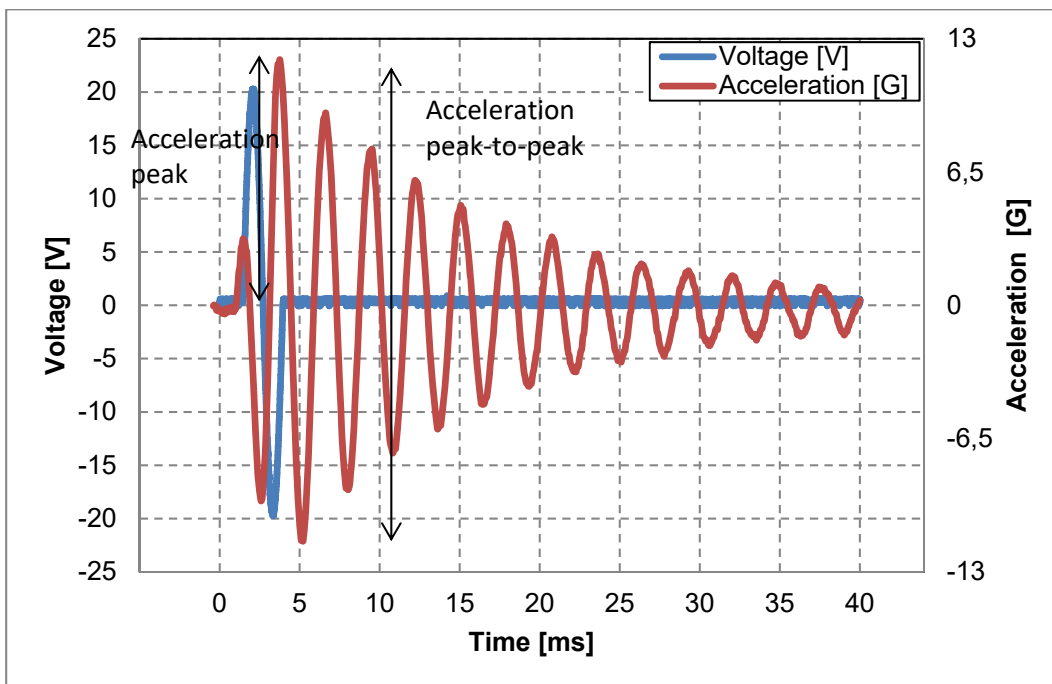

Fig. 6: Typical acceleration as a function of input voltage with 100 g load. Input voltage with a sinus signal form of amplitude -20 ... 20 V and pulse length 5 ms which is equivalent to 200 Hz.

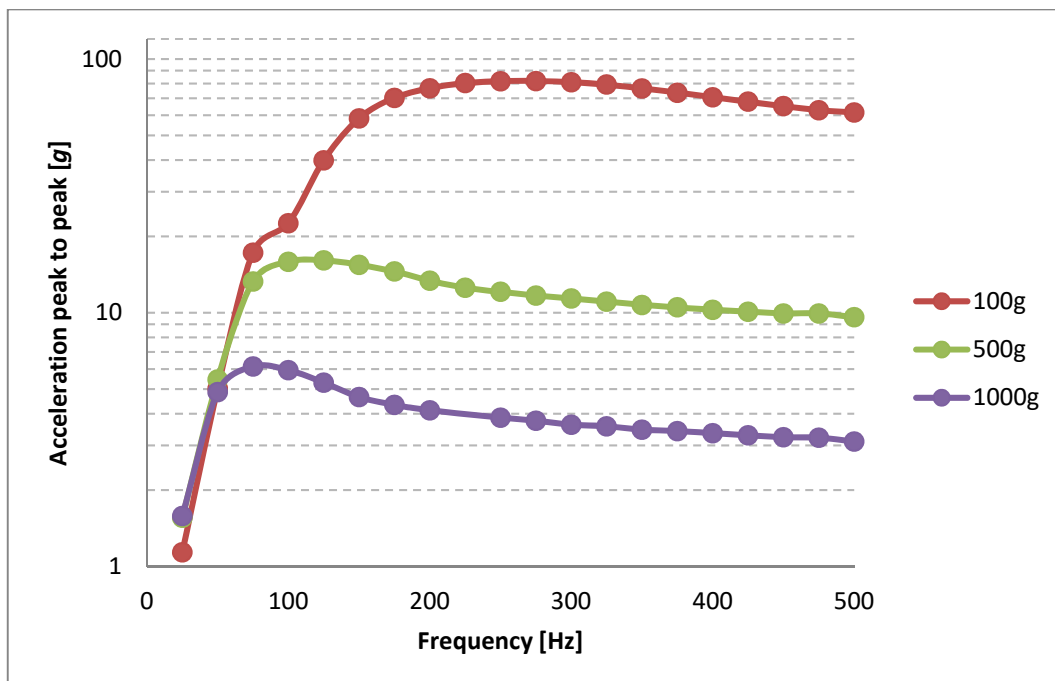

Fig. 7: Acceleration as a function of frequency for different loads. Input voltage has a single pulse half wave sinus signal form of amplitude 0 ... 120 V and varying frequency from 50 Hz ... 500 Hz.

Preliminary data

Application note PowerHap lateral actuators

The PowerHap lateral actuator is suitable for larger loads or displays with larger masses. In such cases, the PowerHap can be placed on the side of the display and movement is in the lateral direction (x-y) as opposed to the vertical direction (z) (see square PowerHap e.g. 2626H023V120). The acceleration of the whole display in xy-direction will result in a sensible haptic feedback for the user. From a subjective point of view, whether you move the load in z- or in xy-direction the sensation of the feedback makes little to no difference.

To ensure the maximum performance the movable load and the rear panel need to provide high stiffness and low-to-none flexibility. Otherwise parts of performance will be lost through the deformation the material. Optimal performance is ensured when the preload on the actuator is in the range of 25 N. In addition to a sufficient preload a none-spatial delimitation of the movement has to be guaranteed for optimal performance.

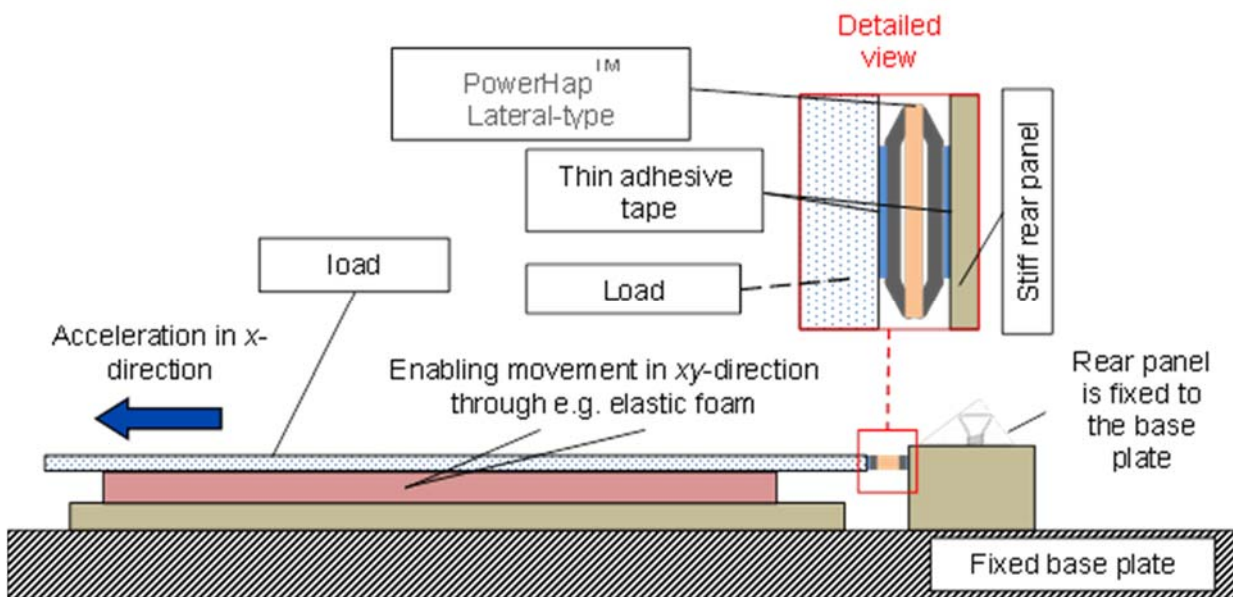

Fig. 8: Schematic drawing of a basic setup including a lateral-type PowerHap actuator attached directly to a load.

The schematic drawing in fig. 8 shows a possible setup involving a lateral-type PowerHap actuator to generate a uniform haptic feedback onto the surface of a relatively heavy display (e.g. automotive application). Best possible performance can be achieved if the load (e.g. display, screen) is able to move freely in the desired direction, meaning that in an ideal case the movement of the display is completely decoupled from the rear panel/frame. In the simplest case the movement in xy-direction can be ensured by the usage of coil springs or a rubber ("floating" setup with no fixation of the display to the rear panel/frame). A decoupled movement of the display and fixation to the rear panel/frame can be achieved by the implementation of a buffer system (a possible buffer design can be found in figure 10). Here it has to be noted, that the elastic buffer has to provide adequate flexibility in xy-direction due to the functionality of the actuator.

Preliminary data

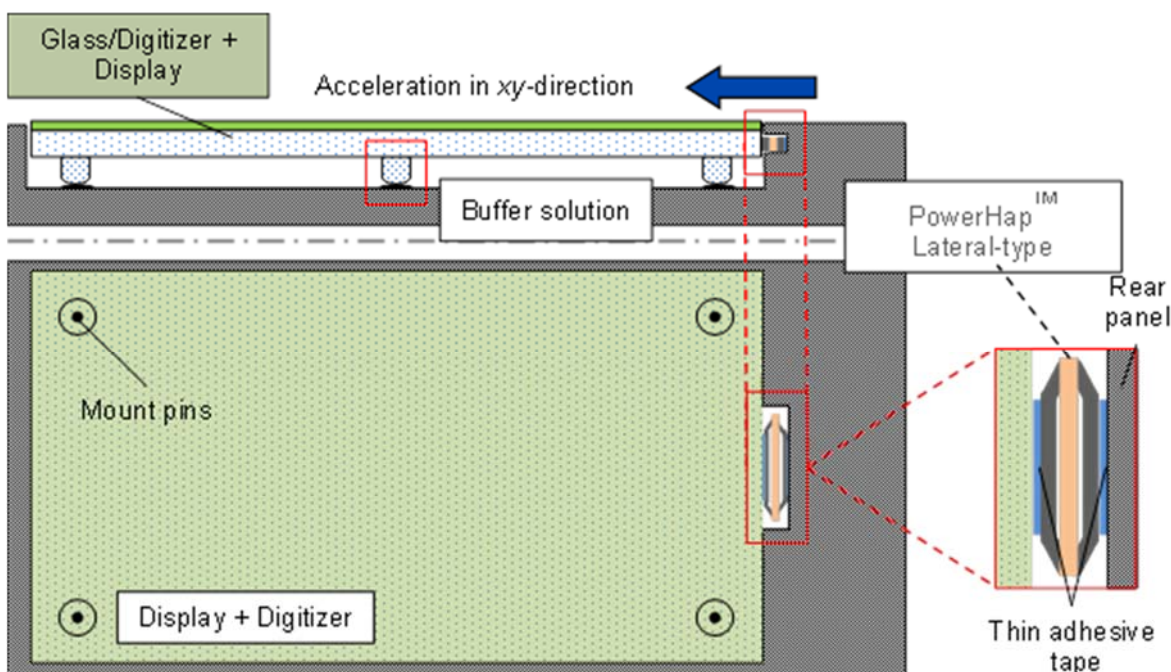

Fig. 9: Schematic drawing of a possible simple integration of a lateral-type PowerHap™ actuator.

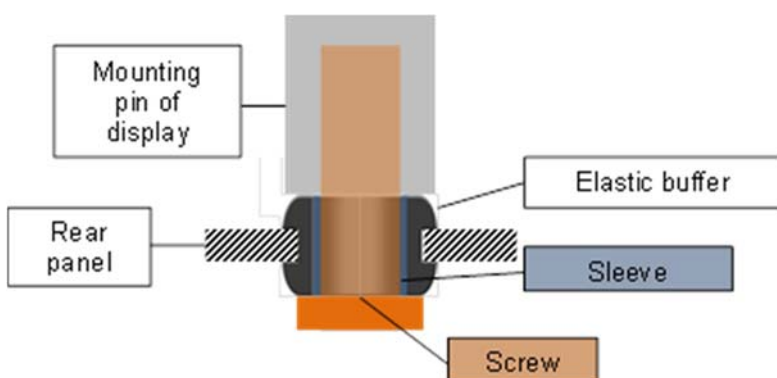

Fig. 10: Schematic drawing of a potential option for a buffer that is able to ensure movement x,y- and z-direction depending on the material and the dimension of the elastic buffer used.

General Application Notes

Some parts of this publication contain statements about the suitability of our ceramic Piezo components for certain areas of application, including recommendations about incorporation/design-in of these products into customer applications. The statements are based on our knowledge of typical requirements made of our devices in the particular areas. We nevertheless expressly point out that such statements cannot be regarded as binding statements about the suitability of our Piezo components for a particular customer application. As a rule, TDK is either unfamiliar with individual customer applications or less familiar with them than the customers themselves. For these reasons, it is always incumbent on the customer to check and decide whether the Piezo component devices with the properties described in the product specification are suitable for use in a particular customer application.

Preliminary data

- Do not use TDK Piezo components for purposes not identified in our specifications, application notes and data books.
- Ensure the suitability of a Piezo component in particular by testing it for reliability during design-in. Always evaluate a Piezo component under worst-case conditions.
- Pay special attention to the reliability of Piezo devices intended for use in safety-critical applications (e.g. medical equipment, automotive, spacecraft, nuclear power plant).
- Do not drive the piezo actuator under resonance conditions

Design notes

- Consider de-rating at higher operating temperatures and loads.
- In some cases the malfunctioning of passive electronic components or failure before the end of their service life cannot be completely ruled out in the current state of the art, even if they are operated as specified. In applications requiring a very high level of operational safety and especially when the malfunction or failure of a passive electronic component could endanger human life or health (e.g. in accident prevention, life-saving systems, or automotive battery line applications such as clamp 30), ensure by suitable design of the application or other measures (e.g. installation of protective circuitry or redundancy) that no injury or damage is sustained by third parties in the event of such a malfunction or failure. Do not use Piezo components in safety-relevant applications.
- Specified values only apply to Piezo components that have not been subject to prior electrical, mechanical or thermal damage.

Operation

- Use piezo actuator components only within the specified operating temperature range.
- Use piezo actuator components only within specified voltage and current ranges.
- Piezo actuator components have to be operated in a dry, non-reducing atmosphere which must not contain any additional chemical vapours or substances. We recommend appropriate drying of all components prior to hermetically sealing.
- We recommend a preload of at least 5 N.
- Prevent a piezo actuator component from contacting liquids and solvents. Make sure that no water enters a piezo actuator component (e.g. through plug terminals).
- Avoid dewing and condensation.
- TDK piezo actuator components are mainly designed for encased applications. Under all circumstances avoid exposure to:
 - direct sunlight
 - rain or condensation
 - steam, saline spray
 - corrosive gases
 - atmosphere with reduced oxygen content
- We expressly point out that in case of non-observance of the aforesaid notes, in particular due to reasons attributable to chemical vapours, a malfunction or failure of the piezo actuator components before the end of their usual service life cannot be completely ruled out, even if they are operated as specified.

Preliminary data

Storage, handling and mounting instructions

Storage

- Store the piezo actuator component with terminals short-circuited.
- Avoid contamination of the piezo actuator component surface during storage.
- Avoid storage of the piezo actuator components in harmful environments where they are exposed to corrosive gases (e.g. SO_x, Cl).
- Storage conditions:
Storage temperature: -25 °C to +45 °C
Relative humidity (RH): ≤ 75% annual average, ≤ 95% on 30 days a year.
Dew precipitation is inadmissible.
- Process piezo actuator components within 12 months after shipment from TDK.

Handling

- Do not drop piezo actuator components or allow them to be chipped.
- Apply maximum force of 10 N at the component during handling.
- Do not touch piezo actuator component with bare hands – powderless nitrile gloves are recommended.
- Avoid contamination of the piezo actuator component surface during handling.

Mounting

- Make sure the surface of the leads is not scratched before, during or after the mounting process.
- Make sure contacts and housings used for assembly with piezo actuator components are clean and dry before mounting.
- Avoid contamination of the surface of the piezo actuator component during processing.
- Make sure ceramic end surfaces are clean before mounting process. We recommend to short-circuit the piezo actuator component during the whole mounting process.
- Avoid any asymmetrical strain at the titanium clips.

Cautions and warnings

The piezo component has to be operated in a dry, non-reducing, open environment and atmosphere which must not contain any chemical vapors or substances.

To prevent damages on the piezo component, tensile stresses must be avoided under all driving conditions.

We expressly point out that in case of non-observance of the aforesaid notes, in particular due to reasons attributable to chemical vapors, a malfunction of the piezo sample or failure before the end of their usual service life cannot be completely ruled out, even if they are operated as specified.

Depending on the individual application, piezo samples are electrically connected to voltages and currents, which are potentially dangerous for life and health of the operator. Installation and operation of piezo sample have to be done only by authorized personnel. Ensure proper and safe connections, couplers, and drivers.

Preliminary data

Caution: Piezo component are highly efficient charge storing capacitors. Even when they are disconnected from a supply, the electrical energy content of a loaded actuator can be high and is held for a long time. Always ensure a complete discharging of an actuator (e.g. via a 10 kOhms resistor) before handling. (Do not discharge by simple short-circuiting, because of the risk of damaging the ceramic.)

Electrical charges can be generated on disconnected actuators by varying load or temperature. Caution: Discharge an actuator before connecting it to a measuring device/electronics, when this device is not sufficiently voltage proofed.

Remark

The products delivered are engineering samples, prototypes or pre-series products, which are not intended for commercial use in series products of the purchaser. TDK assumes no warranty for these products. Any use is at the sole risk of the purchaser.

Contains SVHC Substance 12626-81-2

Display of ordering codes for TDK Electronics products

The ordering code for one and the same product can be represented differently in data sheets, data books, other publications, on the company website, or in order-related documents such as shipping notes, order confirmations and product labels. **The varying representations of the ordering codes are due to different processes employed and do not affect the specifications of the respective products.** Detailed information can be found on the Internet under www.tdk-electronics.tdk.com/orderingcodes.

Important notes

The following applies to all products named in this publication:

1. Some parts of this publication contain **statements about the suitability of our products for certain areas of application**. These statements are based on our knowledge of typical requirements that are often placed on our products in the areas of application concerned. We nevertheless expressly point out **that such statements cannot be regarded as binding statements about the suitability of our products for a particular customer application**. As a rule we are either unfamiliar with individual customer applications or less familiar with them than the customers themselves. For these reasons, it is always ultimately incumbent on the customer to check and decide whether a product with the properties described in the product specification is suitable for use in a particular customer application.
2. We also point out that **in individual cases, a malfunction of electronic components or failure before the end of their usual service life cannot be completely ruled out in the current state of the art, even if they are operated as specified**. In customer applications requiring a very high level of operational safety and especially in customer applications in which the malfunction or failure of an electronic component could endanger human life or health (e.g. in accident prevention or life-saving systems), it must therefore be ensured by means of suitable design of the customer application or other action taken by the customer (e.g. installation of protective circuitry or redundancy) that no injury or damage is sustained by third parties in the event of malfunction or failure of an electronic component.
3. **The warnings, cautions and product-specific notes must be observed.**
4. In order to satisfy certain technical requirements, **some of the products described in this publication may contain substances subject to restrictions in certain jurisdictions (e.g. because they are classed as hazardous)**. Useful information on this will be found in our Material Data Sheets on the Internet (www.tdk-electronics.tdk.com/material). Should you have any more detailed questions, please contact our sales offices.
5. We constantly strive to improve our products. Consequently, **the products described in this publication may change from time to time**. The same is true of the corresponding product specifications. Please check therefore to what extent product descriptions and specifications contained in this publication are still applicable before or when you place an order.

We also **reserve the right to discontinue production and delivery of products**. Consequently, we cannot guarantee that all products named in this publication will always be available. The aforementioned does not apply in the case of individual agreements deviating from the foregoing for customer-specific products.

6. Unless otherwise agreed in individual contracts, **all orders are subject to our General Terms and Conditions of Supply**.
7. **Our manufacturing sites serving the automotive business apply the IATF 16949 standard**. The IATF certifications confirm our compliance with requirements regarding the quality management system in the automotive industry. Referring to customer requirements and customer specific requirements ("CSR") TDK always has and will continue to have the policy of respecting individual agreements. Even if IATF 16949 may appear to support the acceptance of unilateral requirements, we hereby like to emphasize that **only requirements mutually agreed upon can and will be implemented in our Quality Management System**. For clarification purposes we like to point out that obligations from IATF 16949 shall only become legally binding if individually agreed upon.

Important notes

8. The trade names EPCOS, CeraCharge, CeraDiode, CeraLink, CeraPad, CeraPlas, CSMP, CTVS, DeltaCap, DigiSiMic, ExoCore, FilterCap, FormFit, LeaXield, MiniBlue, MiniCell, MKD, MKK, MotorCap, PCC, PhaseCap, PhaseCube, PhaseMod, PhiCap, PowerHap, PQSine, PQvar, SIFERRIT, SIFI, SIKOREL, SilverCap, SIMDAD, SiMic, SIMID, SineFormer, SIOV, ThermoFuse, WindCap are **trademarks registered or pending** in Europe and in other countries. Further information will be found on the Internet at www.tdk-electronics.tdk.com/trademarks.

Release 2018-10

Mouser Electronics

Authorized Distributor

Click to View Pricing, Inventory, Delivery & Lifecycle Information:

[EPCOS / TDK:](#)

[Z63000Z2910Z1Z42](#)

Компания «Океан Электроники» предлагает заключение долгосрочных отношений при поставках импортных электронных компонентов на взаимовыгодных условиях!

Наши преимущества:

- Поставка оригинальных импортных электронных компонентов напрямую с производств Америки, Европы и Азии, а так же с крупнейших складов мира;
- Широкая линейка поставок активных и пассивных импортных электронных компонентов (более 30 млн. наименований);
- Поставка сложных, дефицитных, либо снятых с производства позиций;
- Оперативные сроки поставки под заказ (от 5 рабочих дней);
- Экспресс доставка в любую точку России;
- Помощь Конструкторского Отдела и консультации квалифицированных инженеров;
- Техническая поддержка проекта, помощь в подборе аналогов, поставка прототипов;
- Поставка электронных компонентов под контролем ВП;
- Система менеджмента качества сертифицирована по Международному стандарту ISO 9001;
- При необходимости вся продукция военного и аэрокосмического назначения проходит испытания и сертификацию в лаборатории (по согласованию с заказчиком);
- Поставка специализированных компонентов военного и аэрокосмического уровня качества (Xilinx, Altera, Analog Devices, Intersil, Interpoint, Microsemi, Actel, Aeroflex, Peregrine, VPT, Syfer, Eurofarad, Texas Instruments, MS Kennedy, Miteq, Cobham, E2V, MA-COM, Hittite, Mini-Circuits, General Dynamics и др.);

Компания «Океан Электроники» является официальным дистрибьютором и эксклюзивным представителем в России одного из крупнейших производителей разъемов военного и аэрокосмического назначения «JONHON», а так же официальным дистрибьютором и эксклюзивным представителем в России производителя высокотехнологичных и надежных решений для передачи СВЧ сигналов «FORSTAR».



JONHON

«JONHON» (основан в 1970 г.)

Разъемы специального, военного и аэрокосмического назначения:

(Применяются в военной, авиационной, аэрокосмической, морской, железнодорожной, горно- и нефтедобывающей отраслях промышленности)

«FORSTAR» (основан в 1998 г.)

ВЧ соединители, коаксиальные кабели, кабельные сборки и микроволновые компоненты:

(Применяются в телекоммуникациях гражданского и специального назначения, в средствах связи, РЛС, а так же военной, авиационной и аэрокосмической отраслях промышленности).



Телефон: 8 (812) 309-75-97 (многоканальный)

Факс: 8 (812) 320-03-32

Электронная почта: ocean@oceanchips.ru

Web: <http://oceanchips.ru/>

Адрес: 198099, г. Санкт-Петербург, ул. Калинина, д. 2, корп. 4, лит. А