

# OPTIREG™ Switcher TLF51801

## How to use the TLF51801 demo board

### About this document

#### Scope and purpose

This document describes how to use the OPTIREG™ Switcher TLF51801 demo board.  
Please refer to data sheet for additional information.

## Table of Contents

	<b>About this document</b> .....	<b>1</b>
	<b>Table of Contents</b> .....	<b>2</b>
<b>1</b>	<b>Abstract</b> .....	<b>3</b>
<b>2</b>	<b>Description</b> .....	<b>4</b>
2.1	Quick Start .....	4
2.2	Demo board description .....	5
2.3	Adjustment of output voltage $V_{OUT}$ and external Bootstrap Diode .....	7
2.4	Current limitation configurations .....	8
2.5	Input filter .....	10
<b>3</b>	<b>Revision History</b> .....	<b>11</b>

**Abstract**

## **1 Abstract**

The following application note shall enable the user to operate the TLF51801ELV demo board. The TLF51801ELV is a Step-Down controller with external power stage, capable to deliver 10 A or more (depending on Mosfets of external power stage) and adjustable output voltage.

The board is equipped with a TLF51801ELV, it is preset to 5 V output voltage, current limitation is set to ~5 A. Current limitation may be done via shunt resistor or via  $R_{\text{DS(on)}}$  measurement of highside Mosfet, the board offers both possibilities. The board is preadjusted for shunt current limitation.

The board offer the possibility to modify the schematic. Please refer to the data sheet for more information.

*Note: The following information is given as a hint for the implementation of our devices only and shall not be regarded as a description or warranty of a certain functionality, condition or quality of the device.*

**Description**

## 2 Description

### 2.1 Quick Start

The following figure shows how to connect the application board for operation

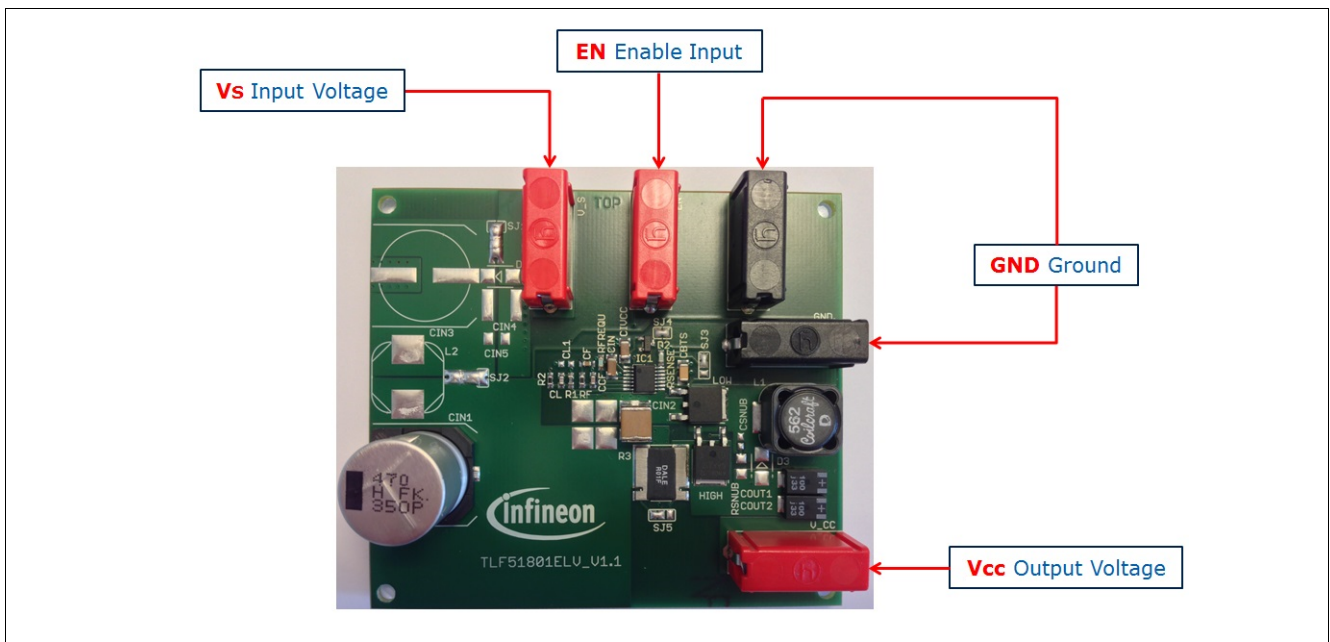

**Figure 1 Quick Start - How to connect the demo board**

**Description**

**2.2 Demo board description**

A TLF51801ELV demo board is used to demonstrate the behavior of the device.

The demo board is supplied by a laboratory power supply with variable input voltage, the output is connected to a resistive load. The following figures show the schematic and the bill of material of the demo board.

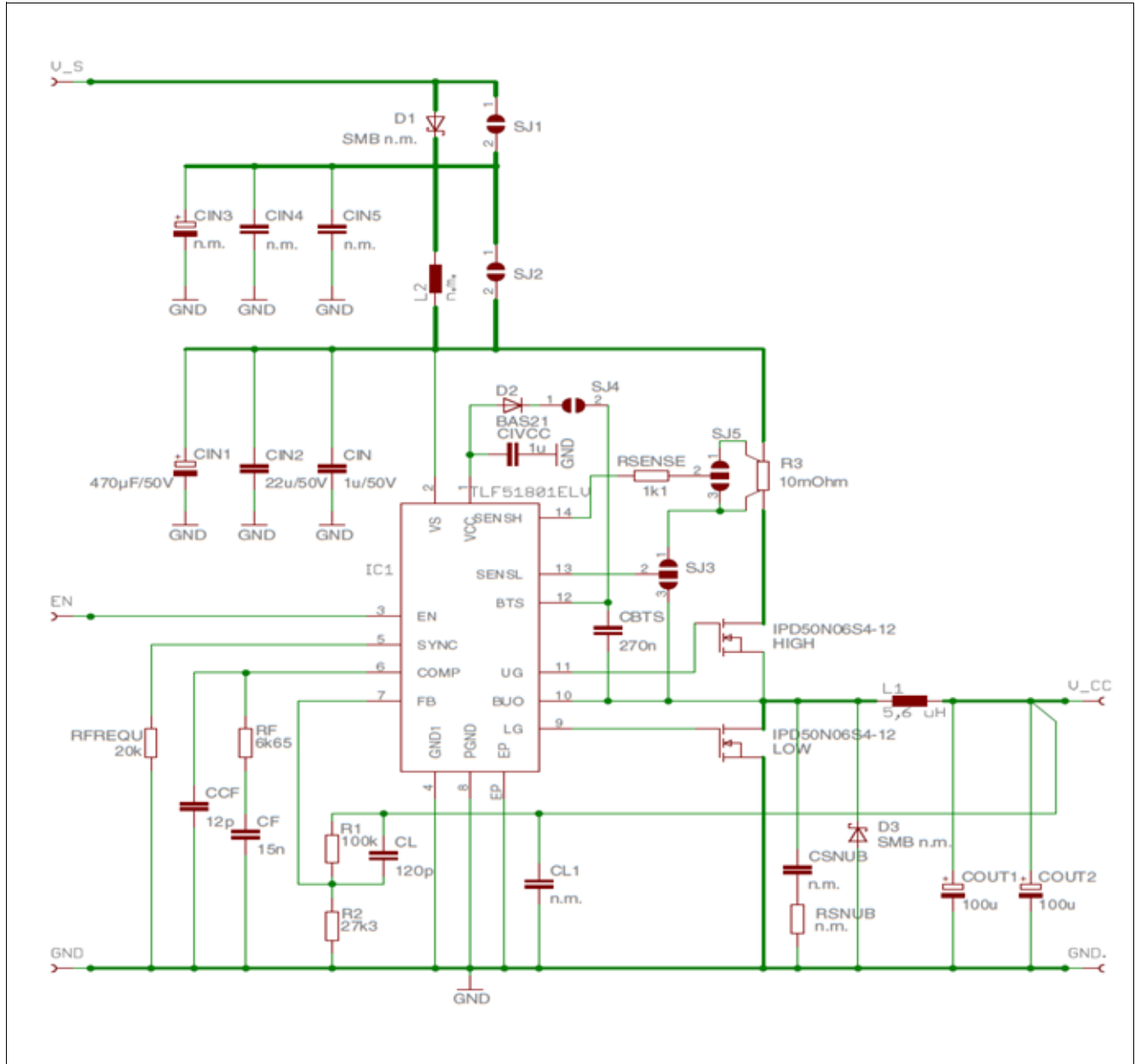

**Figure 2 Demoboard schematic**

**Description**

Ref	Value	Manufacturer	Part number	Type	Qty
L <sub>1</sub>	5.6μH	Coilcraft	MSS1278T-562ML_	Inductor	1
LOW, HIGH	N-ch, 60 V, 12 mΩ	Infineon	IPD50N06S4L-12	Transistor	2
C <sub>OUT1</sub> , C <sub>OUT2</sub>	100μF - 10mΩ ESR	Rubycon	6SW100M	Capacitor, Poly Al, 6.3V	2
C <sub>IN2</sub>	22μF	Kemet	C2220C226M5R2CTU	Capacitor, X7R, 50V	1
C <sub>IN1</sub>	470μF	Panasonic	EEEFK1H471AM	Capacitor, Al, 50V	1
R <sub>FREQ</sub>	20kΩ	Panasonic	ERJ3EKF2002V	Resistor, ±1%, 0.1W	1
R <sub>1</sub>	100kΩ	Panasonic	ERJ3EKF1003V	Resistor, ±1%, 0.1W	1
R <sub>2</sub>	27.3kΩ	Panasonic	ERJ3EKF2742V	Resistor, ±1%, 0.1W	1
R <sub>F</sub>	6.65kΩ	Panasonic	ERJ3EKF6651V	Resistor, ±1%, 0.1W	1
R <sub>sense</sub>	1.1kΩ	Panasonic	ERJ3EKF1101V	Resistor, ±1%, 0.1W	1
R <sub>shunt</sub>	10mΩ	Vishay Dale	WSL3637R0100FEB	Resistor, ±1%, 3W	1
C <sub>CF</sub>	12pF	Kemet	C0603C120J5GACTU	Capacitor, COG	1
C <sub>L</sub>	120pF	Kemet	C0603C121J5GACTU	Capacitor, COG	1
C <sub>F</sub>	15nF	Kemet	C0603C153K5RACTU	Capacitor, X7R, 50V	1
C <sub>IVCC</sub>	1μF	Kemet	C1206C105K4RACTU	Capacitor, X7R, 16V	1
C <sub>IN</sub>	1μF	Kemet	C1206C105K5RACTU	Capacitor, X7R, 50V	1
C <sub>BTS</sub>	270nF	Kemet	C1206C274K5RACTU	Capacitor, X7R, 50V	1

**Figure 3 Demoboard bill of material**

**Description**

**2.3 Adjustment of output voltage  $V_{OUT}$  and external Bootstrap Diode**

The output voltage of the demo board is adjustable in the range 1.2 V up to  $D_{max} * V_S$  varying the ratio between R1 and R2 (both marked within yellow frame)

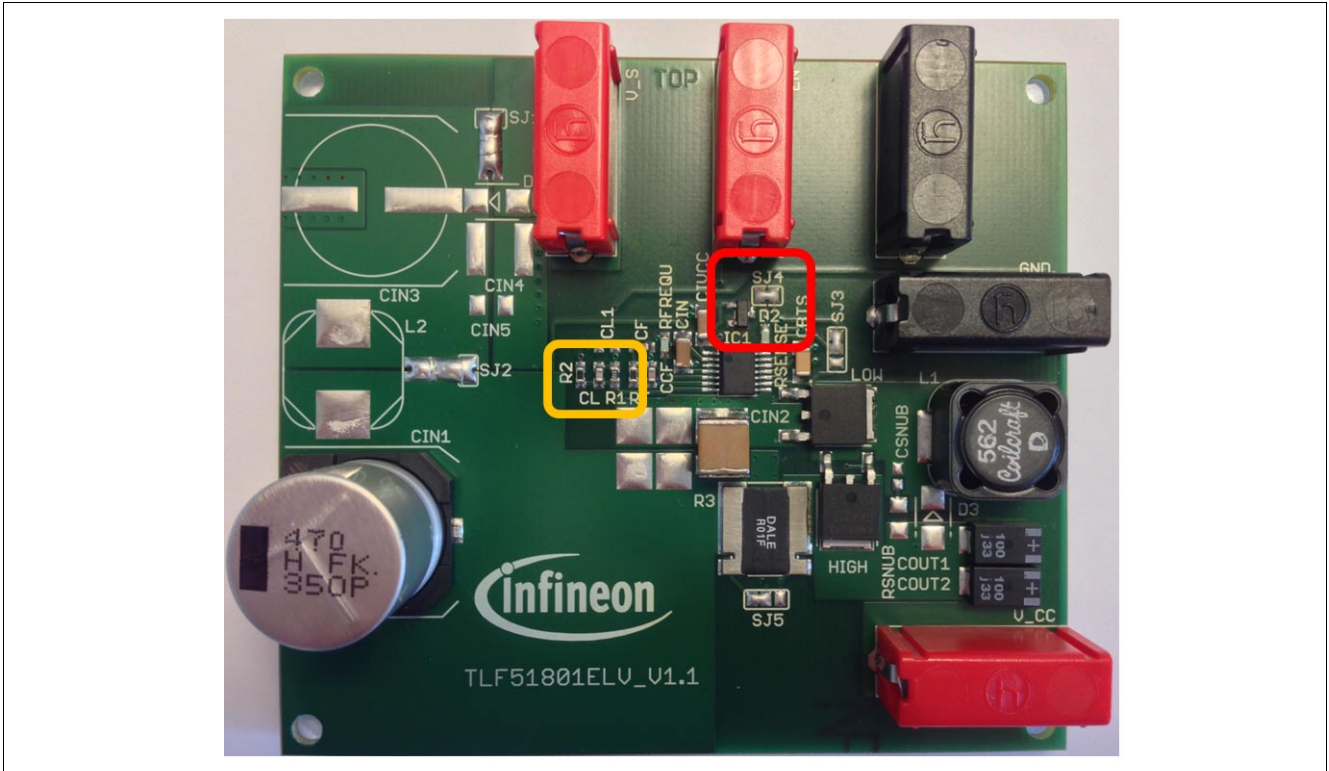

**Figure 4 Adjustment of  $V_{OUT}$  and external BTS diode**

Beside the internal bootstrap diode there is the possibility to run the device up to ~ 99% duty cycle just using an external BTS diode (Schottky). The place is marked by a red frame.

If a very high duty cycle is not needed please remove the short on SJ4 between 1 and 2 (marked with red frame, please refer also to figure 2 schematic. In this case the device will run at maximum 91% duty cycle.

For more details please refer to data sheet.

Description

## 2.4 Current limitation configurations

The TLF51801ELV permits to implement the current limitation adopting two methods:

**Via Shunt resistor:** This method is more precise but requires area on the PCB and an additional component.

**Via of the  $R_{DS(ON)}$  high side Mosfet:** Less precise but cost-effective solution and efficiency optimization.

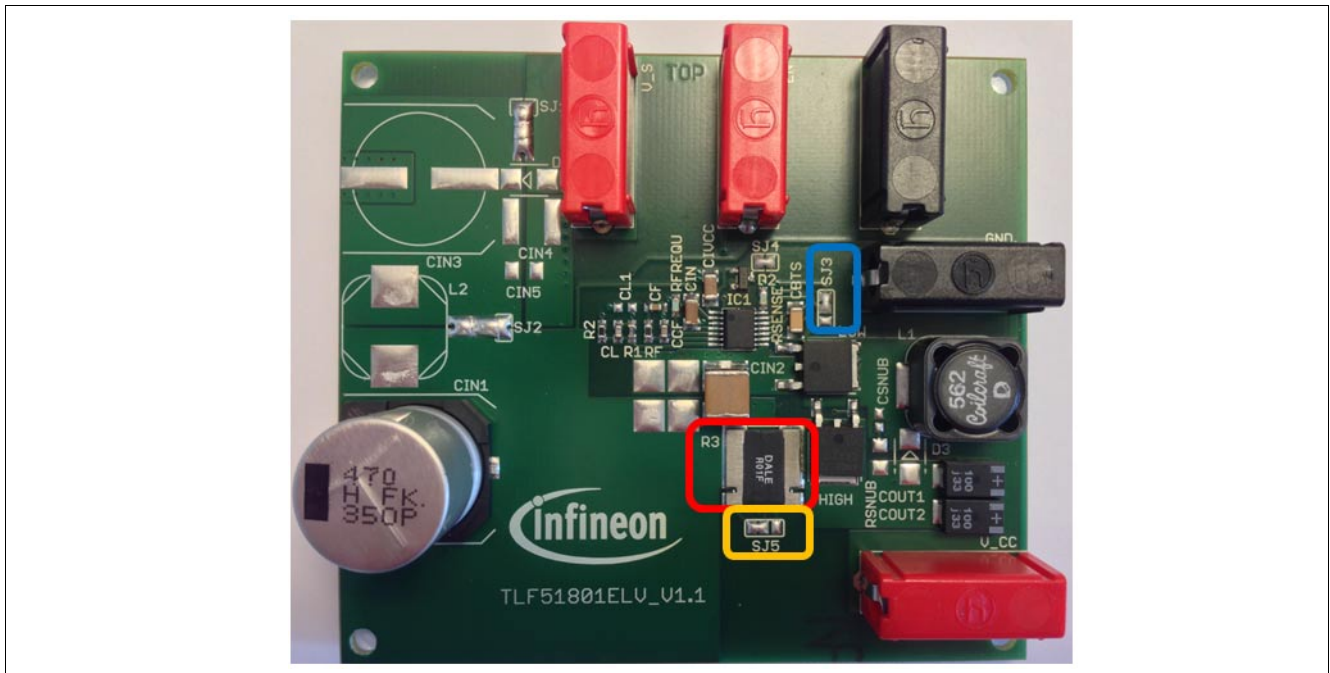

**Figure 5 Current limitation via shunt resistor**

The demo board is equipped with a shunt resistor R3 (red frame), allowing the user to test the shunt resistor method for the current limitation. The shunt resistor is located in series to the drain of the high side Mosfet (please refer to data sheet for detailed explanation)

Please mount the desired shunt resistor and connect SJ5 (yellow frame) between 1 and 2 and SJ3 (blue frame) between 1 and 2- please refer to figure 2 schematic

Please note that the demo board is configured in shunt resistor current limitation configuration.



Description

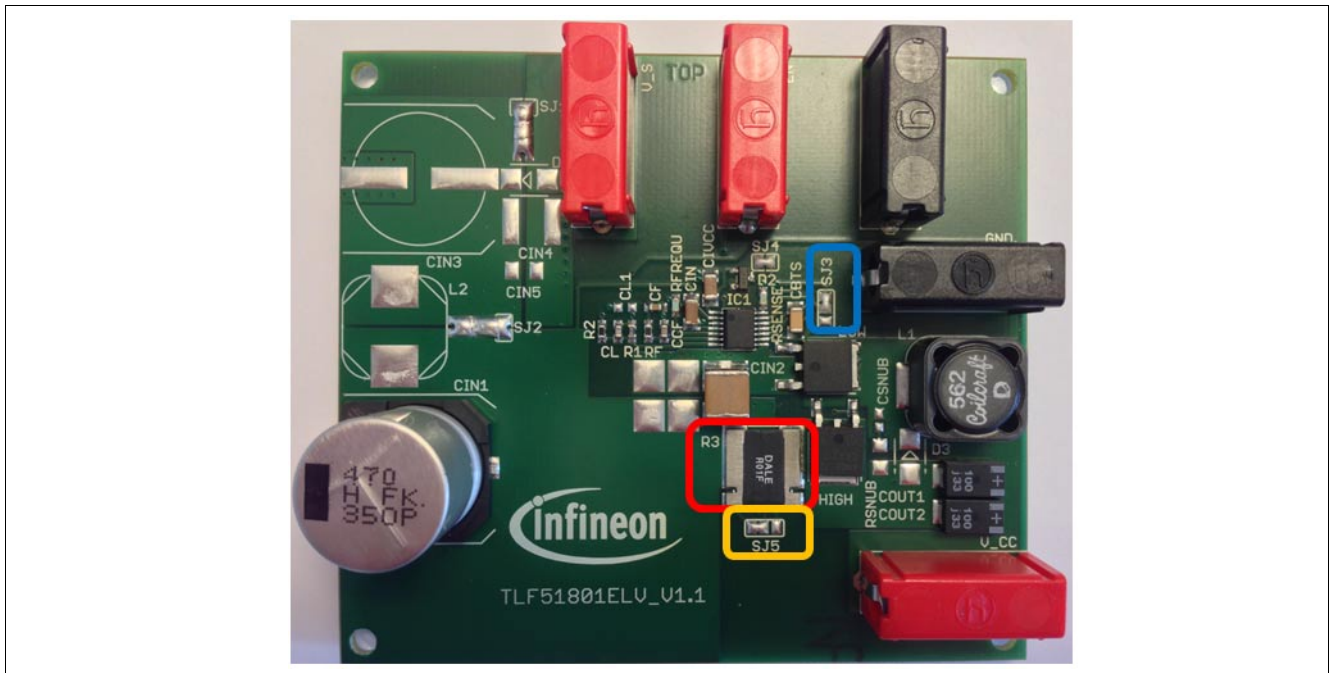

Figure 6 Current limitation via  $R_{DSON}$

The demo board allows the user to test the  $R_{DSON}$  method for the current limitation. The built-in  $R_{DSON}$  of the high side Mosfet is used together with the  $R_{SENCE}$  to create the voltage divider (please refer to data sheet for detailed explanation)

Please bypass the shunt resistor simply connecting SJ5 (yellow frame) between 2 and 3 and SJ3 (blue frame) between 2 and 3 - please refer to figure 2 schematic

Remove the shunt resistor (red frame) in series to the drain of the high side Mosfet.

**Description**

**2.5 Input filter**

If needed there is the possibility foreseen to mount an input filter on the demo board, the mounting area is shown by red frame..

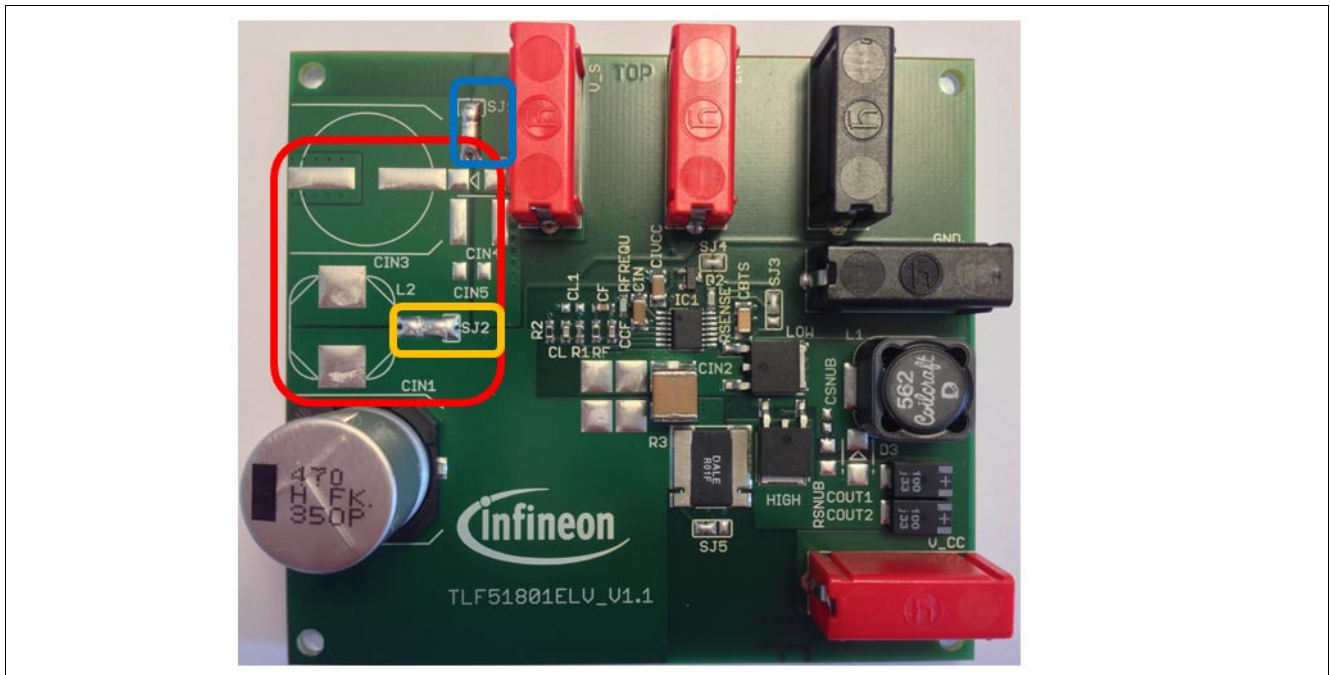

**Figure 7 Input filter**

If the input filter is not mounted please connect S1 (blue frame) between 1 and 2 and S2 (yellow frame) between 1 and 2 - please refer to figure 2 schematic

The demo board is preset for testing without input filter

**Revision History**

### **3 Revision History**

<b>Revision</b>	<b>Date</b>	<b>Changes</b>
1.0	2018-08-01	Application Note created.

#### **Trademarks of Infineon Technologies AG**

All referenced product or service names and trademarks are the property of their respective owners.

**Edition 2018-08-01**

**Published by**

**Infineon Technologies AG**

**81726 Munich, Germany**

**© 2018 Infineon Technologies AG.**

**All Rights Reserved.**

**Do you have a question about any aspect of this document?**

**Email: [erratum@infineon.com](mailto:erratum@infineon.com)**

**Document reference**

**Z8F62791010**

#### **IMPORTANT NOTICE**

The information contained in this application note is given as a hint for the implementation of the product only and shall in no event be regarded as a description or warranty of a certain functionality, condition or quality of the product. Before implementation of the product, the recipient of this application note must verify any function and other technical information given herein in the real application. Infineon Technologies hereby disclaims any and all warranties and liabilities of any kind (including without limitation warranties of non-infringement of intellectual property rights of any third party) with respect to any and all information given in this application note.

The data contained in this document is exclusively intended for technically trained staff. It is the responsibility of customer's technical departments to evaluate the suitability of the product for the intended application and the completeness of the product information given in this document with respect to such application.

For further information on technology, delivery terms and conditions and prices, please contact the nearest Infineon Technologies Office ([www.infineon.com](http://www.infineon.com)).

#### **WARNINGS**

Due to technical requirements products may contain dangerous substances. For information on the types in question please contact your nearest Infineon Technologies office.

Except as otherwise explicitly approved by Infineon Technologies in a written document signed by authorized representatives of Infineon Technologies, Infineon Technologies' products may not be used in any applications where a failure of the product or any consequences of the use thereof can reasonably be expected to result in personal injury.

# Mouser Electronics

Authorized Distributor

Click to View Pricing, Inventory, Delivery & Lifecycle Information:

[Infineon:](#)

[DEMOBOARDTLF51801ELTOBO1](#)

Компания «Океан Электроники» предлагает заключение долгосрочных отношений при поставках импортных электронных компонентов на взаимовыгодных условиях!

Наши преимущества:

- Поставка оригинальных импортных электронных компонентов напрямую с производств Америки, Европы и Азии, а так же с крупнейших складов мира;
- Широкая линейка поставок активных и пассивных импортных электронных компонентов (более 30 млн. наименований);
- Поставка сложных, дефицитных, либо снятых с производства позиций;
- Оперативные сроки поставки под заказ (от 5 рабочих дней);
- Экспресс доставка в любую точку России;
- Помощь Конструкторского Отдела и консультации квалифицированных инженеров;
- Техническая поддержка проекта, помощь в подборе аналогов, поставка прототипов;
- Поставка электронных компонентов под контролем ВП;
- Система менеджмента качества сертифицирована по Международному стандарту ISO 9001;
- При необходимости вся продукция военного и аэрокосмического назначения проходит испытания и сертификацию в лаборатории (по согласованию с заказчиком);
- Поставка специализированных компонентов военного и аэрокосмического уровня качества (Xilinx, Altera, Analog Devices, Intersil, Interpoint, Microsemi, Actel, Aeroflex, Peregrine, VPT, Syfer, Eurofarad, Texas Instruments, MS Kennedy, Miteq, Cobham, E2V, MA-COM, Hittite, Mini-Circuits, General Dynamics и др.);

Компания «Океан Электроники» является официальным дистрибьютором и эксклюзивным представителем в России одного из крупнейших производителей разъемов военного и аэрокосмического назначения «**JONHON**», а так же официальным дистрибьютором и эксклюзивным представителем в России производителя высокотехнологичных и надежных решений для передачи СВЧ сигналов «**FORSTAR**».



## JONHON

«**JONHON**» (основан в 1970 г.)

Разъемы специального, военного и аэрокосмического назначения:

(Применяются в военной, авиационной, аэрокосмической, морской, железнодорожной, горно- и нефтедобывающей отраслях промышленности)

«**FORSTAR**» (основан в 1998 г.)

ВЧ соединители, коаксиальные кабели,  
кабельные сборки и микроволновые компоненты:

(Применяются в телекоммуникациях гражданского и специального назначения, в средствах связи, РЛС, а так же военной, авиационной и аэрокосмической отраслях промышленности).



Телефон: 8 (812) 309-75-97 (многоканальный)

Факс: 8 (812) 320-03-32

Электронная почта: [ocean@oceanchips.ru](mailto:ocean@oceanchips.ru)

Web: <http://oceanchips.ru/>

Адрес: 198099, г. Санкт-Петербург, ул. Калинина, д. 2, корп. 4, лит. А