

## DESCRIPTION

Demonstration circuit 614 is a monolithic step-down DC/DC switching converter featuring the LT<sup>®</sup>3434. The board is optimized for 3.3V output at up to 2A load current for a steady state input voltage range of 4V to about 42V\* with input transients up to 60V. *Minimum on-time restrictions and 3.3V output may limit the steady state maximum input voltage to 42V before pulse skipping occurs.* With its wide input voltage range, 3A internal power switch, 100 $\mu$ A supply current (at input voltages above 14V), 200kHz switching frequency and thermally enhanced package, the LT3434 is a very versatile and powerful IC for DC/DC converters that require compact space, high efficiency at both heavy and light loads and high input voltage.

The LT3434 200kHz switching frequency allows all of the components to be small, surface mount devices. Synchronization with an external clock of up to 700kHz is possible. The current-mode control topology creates fast transient response and good loop stability with a minimum number of external components. The low resistance internal power switch (0.1 $\Omega$ ) achieves high efficiencies of up to 80%. The shutdown pin can be used to program undervoltage lockout or place the part in micropower shutdown, reducing supply current to less than 1 $\mu$ A by driving the pin low. Burst Mode<sup>™</sup> reduces zero load current

to under 100 $\mu$ A at most input voltages while maintaining a regulated output. A power good comparator and a timing delay can be used for additional system diagnostics and sequencing. The soft start function reduces inrush current at soft start and output voltage overshoot. An optional Power Good Feedback output terminal can be used to monitor or control power good feedback externally.

The LT3434 datasheet gives a complete description of the part, operation and applications information. The datasheet must be read in conjunction with this Quick Start Guide for demonstration circuit 614. In particular, the datasheet section on 'Thermal Calculations' is important for estimating whether a given application's combination of input voltage, load current and frequency will cause the LT3434 to exceed its absolute maximum rated junction temperature. The LT3434 is assembled in a small 16-pin thermally enhanced package with exposed pad where proper board layout is essential for maximum thermal performance. See the datasheet section 'Layout Considerations'.

**Design files for this circuit board are available. Call the LTC factory.**

---

LT is a trademark of Linear Technology Corporation

## QUICK START PROCEDURE

Demonstration circuit 614 is easy to set up to evaluate the performance of the LT3434. Refer to Figure 1 for proper measurement equipment setup and follow the procedure below:

**NOTE:** Make sure that the input voltage does not exceed 60V.

**NOTE:** The synchronization, shutdown, and power good functions are optional and their terminals can

be left floating (disconnected) if their functions are not being used.

**NOTE:** Do not hot-plug the input voltage terminal VIN. The absolute maximum voltage on VIN is 60V and hot-plugging a power supply through wire leads to the demonstration circuit can cause the voltage on the extremely low-ESR ceramic input capacitor to ring to twice its DC value. This is due to high currents instantaneously generated in the inductive supply leads

# QUICK START GUIDE FOR DEMONSTRATION CIRCUIT 614

## 60V 3A 200KHZ STEP-DOWN CONVERTER WITH BURST MODE

from an input voltage step on the low-ESR ceramic input capacitor. A bulky higher-ESR capacitor, and an additional inductive filter can be added to the circuit to dampen hot-plug transient ringing. *See Application Note 88 for more details.* In order to protect the IC, a transient voltage suppressor diode can be added between VIN and GND terminals to absorb any high voltage transient ringing that may occur due to hot-plugging.

**NOTE:** Connect the power supply (with power off), load, and meters as shown in Figure 1.

1. After all connections are made, turn on input power and verify that the output voltage is 3.3V.

**NOTE:** If the output voltage is too low, temporarily disconnect the load to make sure that the load is not set too high.

2. Once the proper output voltages are established, adjust the load within the operating range and observe the output voltage regulation, ripple voltage, efficiency and other parameters.

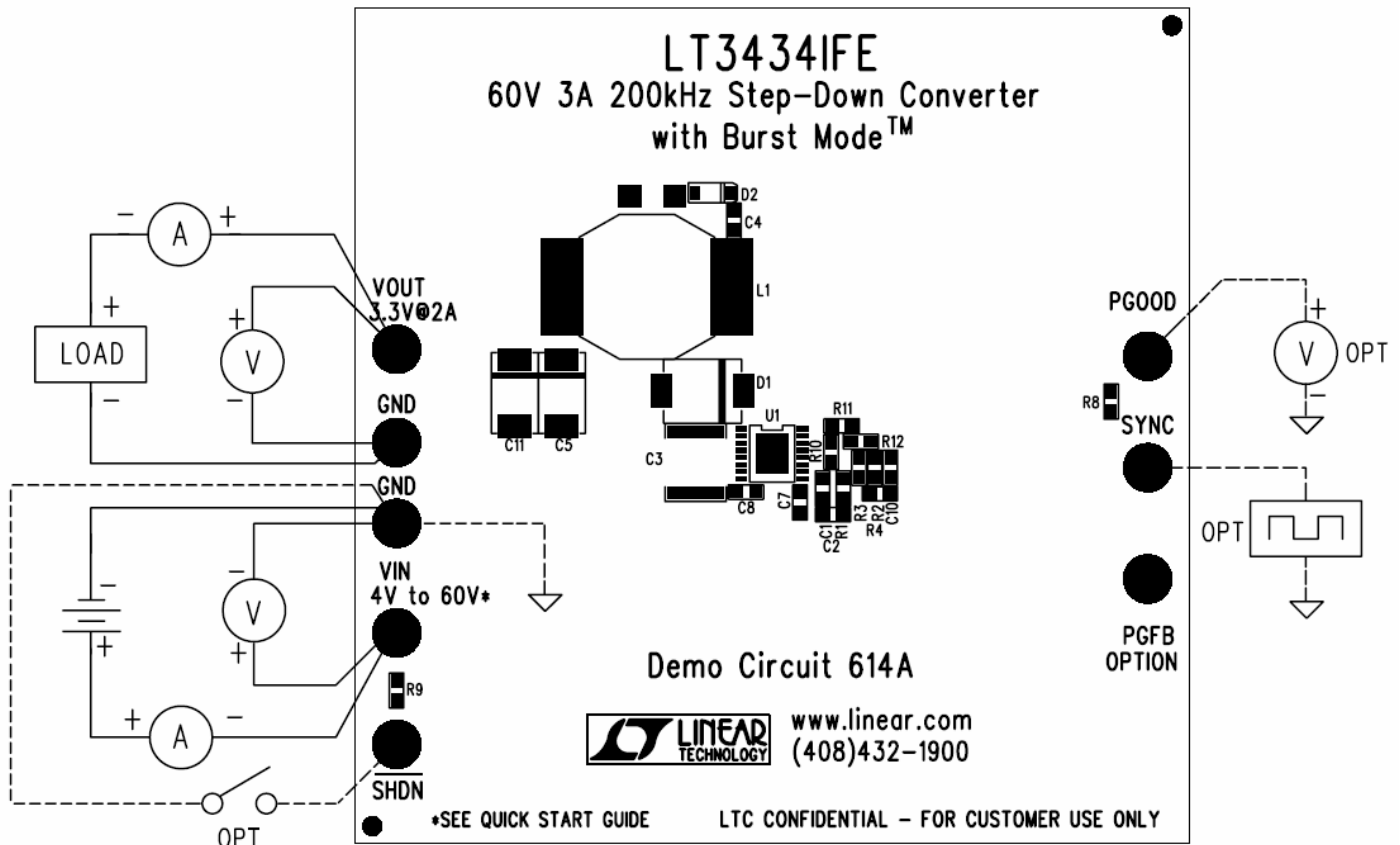
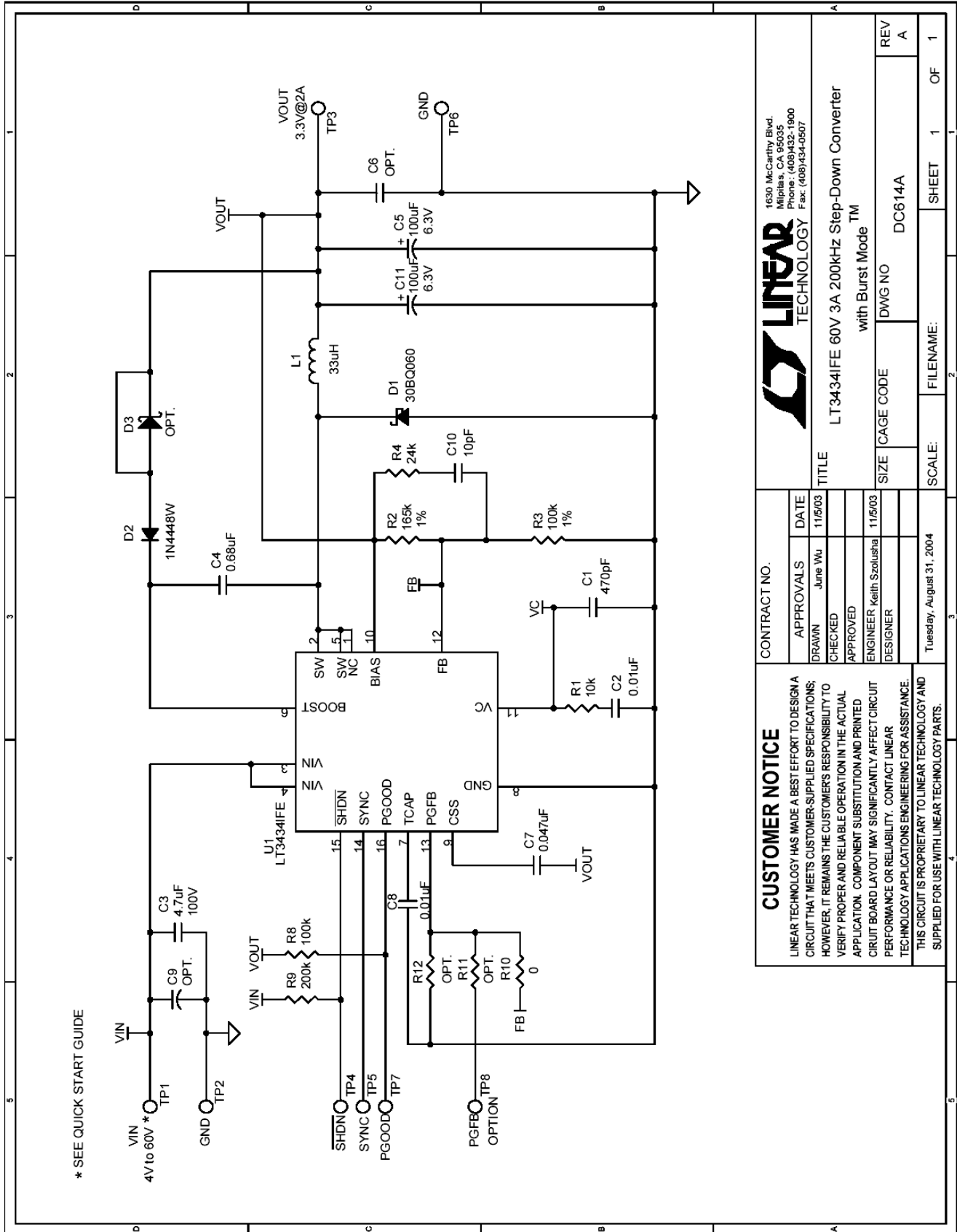

Figure 1. Proper Measurement Equipment Setup

# QUICK START GUIDE FOR DEMONSTRATION CIRCUIT 614

## 60V 3A 200KHz STEP-DOWN CONVERTER WITH BURST MODE



\* SEE QUICK START GUIDE

**CUSTOMER NOTICE**

LINEAR TECHNOLOGY HAS MADE A BEST EFFORT TO DESIGN A CIRCUIT THAT MEETS CUSTOMER-SUPPLIED SPECIFICATIONS; HOWEVER, IT REMAINS THE CUSTOMER'S RESPONSIBILITY TO VERIFY PROPER AND RELIABLE OPERATION IN THE ACTUAL APPLICATION. COMPONENT SUBSTITUTION AND PRINTED CIRCUIT BOARD LAYOUT MAY SIGNIFICANTLY AFFECT CIRCUIT PERFORMANCE OR RELIABILITY. CONTACT LINEAR TECHNOLOGY APPLICATIONS ENGINEERING FOR ASSISTANCE.

THIS CIRCUIT IS PROPRIETARY TO LINEAR TECHNOLOGY AND SUPPLIED FOR USE WITH LINEAR TECHNOLOGY PARTS.

**CONTRACT NO.:**

APPROVALS	DATE
DRAWN June Wu	11/5/03
CHECKED	
APPROVED	
ENGINEER Keith Szolusha	11/5/03
DESIGNER	

Tuesday, August 31, 2004

**LINEAR TECHNOLOGY**

1630 McCarthy Blvd.  
Milpitas, CA 95035  
Phone: (408)432-1900  
Fax: (408)434-0507

**TITLE**  
LT3434IFE 60V 3A 200kHz Step-Down Converter with Burst Mode™

**SIZE** CAGE CODE DWG NO DC614A REV A

**SCALE:** FILENAME: SHEET 1 OF 1

Компания «Океан Электроники» предлагает заключение долгосрочных отношений при поставках импортных электронных компонентов на взаимовыгодных условиях!

Наши преимущества:

- Поставка оригинальных импортных электронных компонентов напрямую с производств Америки, Европы и Азии, а так же с крупнейших складов мира;
- Широкая линейка поставок активных и пассивных импортных электронных компонентов (более 30 млн. наименований);
- Поставка сложных, дефицитных, либо снятых с производства позиций;
- Оперативные сроки поставки под заказ (от 5 рабочих дней);
- Экспресс доставка в любую точку России;
- Помощь Конструкторского Отдела и консультации квалифицированных инженеров;
- Техническая поддержка проекта, помощь в подборе аналогов, поставка прототипов;
- Поставка электронных компонентов под контролем ВП;
- Система менеджмента качества сертифицирована по Международному стандарту ISO 9001;
- При необходимости вся продукция военного и аэрокосмического назначения проходит испытания и сертификацию в лаборатории (по согласованию с заказчиком);
- Поставка специализированных компонентов военного и аэрокосмического уровня качества (Xilinx, Altera, Analog Devices, Intersil, Interpoint, Microsemi, Actel, Aeroflex, Peregrine, VPT, Syfer, Eurofarad, Texas Instruments, MS Kennedy, Miteq, Cobham, E2V, MA-COM, Hittite, Mini-Circuits, General Dynamics и др.);

Компания «Океан Электроники» является официальным дистрибьютором и эксклюзивным представителем в России одного из крупнейших производителей разъемов военного и аэрокосмического назначения «JONHON», а так же официальным дистрибьютором и эксклюзивным представителем в России производителя высокотехнологичных и надежных решений для передачи СВЧ сигналов «FORSTAR».



## JONHON

«JONHON» (основан в 1970 г.)

Разъемы специального, военного и аэрокосмического назначения:

(Применяются в военной, авиационной, аэрокосмической, морской, железнодорожной, горно- и нефтедобывающей отраслях промышленности)

«FORSTAR» (основан в 1998 г.)

ВЧ соединители, коаксиальные кабели, кабельные сборки и микроволновые компоненты:

(Применяются в телекоммуникациях гражданского и специального назначения, в средствах связи, РЛС, а так же военной, авиационной и аэрокосмической отраслях промышленности).



Телефон: 8 (812) 309-75-97 (многоканальный)

Факс: 8 (812) 320-03-32

Электронная почта: [ocean@oceanchips.ru](mailto:ocean@oceanchips.ru)

Web: <http://oceanchips.ru/>

Адрес: 198099, г. Санкт-Петербург, ул. Калинина, д. 2, корп. 4, лит. А