

# SSL - Discrete Wire IDC Contact & Cap

## Series 9176-400



The 917X series of surface mount Insulation Displacement Connectors (IDC) were developed to meet the harsh automotive and industrial market applications for connecting individual wires directly to a PCB ranging from 14 AWG to 28 AWG. This industry proven contact system has been tested to automotive levels of shock, vibration, and temperature cycling to prove their reliability and robustness. This new single contact was developed as a standalone component to enhance the application uses with the IDC technology. The simplicity of inserting a wire into an SMT contact with a small tool or optional retention / termination cap allows a wide range of devices to be connected to the PCB without soldering. In SSL applications specifically, these contacts are used to bring power and signal onto the PCB or are used to daisy chain multiple boards together in a long string. While the IDC contact provides a gas-tight connection to conductor of the wire, the optional cap provides a positive strain relief even in the harshest conditions. In case of repair, the wires can be removed and replace up to three times.

The single 9176-400 series contact and cap accepts 22 AWG to 24 AWG wires with an insulation diameter ranging from 1.0mm to 1.5mm. These dual beam contacts support a 6 amp current rating with a large SMT solder base to provide maximum stability on the PCB. The optional locking strain relief cap acts as the termination tool for severe vibration applications.

### APPLICATIONS

- Connecting discrete wire components directly to the PCB
- Bringing power and signals onto a PCB
- Daisy chaining PCB's together to create a continuous string of boards
- Application notes: refer to 201-01-124

### FEATURES AND BENEFITS

- IDC contact is supplied in T&R pockets for standard SMT placement
- IDC contact provides a gas-tight connection to the PCB for long term reliability
- Optional termination cap provides additional strain relief for severe environments
- Tested to automotive levels on shock, vibration and temperature cycling for reliability
- Reduced total applied cost versus solder or crimp processes
- Individual contacts can be located anywhere on the PCB based on specific application

### ELECTRICAL

- Current Rating: 6 Amps/Contact
- Voltage Rating: Dependant on component proximity

### ENVIRONMENTAL

- Operating Temperature: -40°C to +125°C

### MECHANICAL

- Insulator Material: Nylon 46: UL94V0
- Contact Material: Phosphor Bronze
- Plating: Tin over Nickel
- Durability: 3 Cycles

### HOW TO ORDER – CONTACT OPTIONS

<b>70</b>	<b>9176</b>	<b>001</b>	<b>4XX</b>	<b>006</b>												
Prefix	Series	Number of Ways	Wire Gauge Size	Plating Option												
70 = Contact				06 = Pure Tin all over												
		<table border="1"> <thead> <tr> <th>Code</th> <th>No of Ways</th> <th>Details</th> </tr> </thead> <tbody> <tr> <td>001</td> <td>1</td> <td>Page 53</td> </tr> </tbody> </table>	Code	No of Ways	Details	001	1	Page 53	<table border="1"> <thead> <tr> <th>Code</th> <th>Accepted Wire Gauge</th> </tr> </thead> <tbody> <tr> <td>422</td> <td>22 Gauge Stranded</td> </tr> <tr> <td>432</td> <td>24 Gauge Stranded</td> </tr> </tbody> </table>	Code	Accepted Wire Gauge	422	22 Gauge Stranded	432	24 Gauge Stranded	
Code	No of Ways	Details														
001	1	Page 53														
Code	Accepted Wire Gauge															
422	22 Gauge Stranded															
432	24 Gauge Stranded															

### HOW TO ORDER – CAP OPTIONS

<b>60</b>	<b>9176</b>	<b>001</b>	<b>4XX</b>	<b>X00</b>																			
Prefix	Series	Number of Ways	Wire Gauge Size	Insulator Color																			
60 = Cap																							
		<table border="1"> <thead> <tr> <th>Code</th> <th>No of Ways</th> <th>Details</th> </tr> </thead> <tbody> <tr> <td>001</td> <td>1</td> <td>Page 55</td> </tr> </tbody> </table>	Code	No of Ways	Details	001	1	Page 55	<table border="1"> <thead> <tr> <th>Code</th> <th>Wire Insulation</th> </tr> </thead> <tbody> <tr> <td>415</td> <td>Ø 1.0-1.5</td> </tr> </tbody> </table>	Code	Wire Insulation	415	Ø 1.0-1.5	<table border="1"> <thead> <tr> <th>Code</th> <th>Color</th> <th>Application</th> </tr> </thead> <tbody> <tr> <td>000</td> <td>Black</td> <td>Industrial</td> </tr> <tr> <td>100</td> <td>White</td> <td>Lighting</td> </tr> </tbody> </table>	Code	Color	Application	000	Black	Industrial	100	White	Lighting
Code	No of Ways	Details																					
001	1	Page 55																					
Code	Wire Insulation																						
415	Ø 1.0-1.5																						
Code	Color	Application																					
000	Black	Industrial																					
100	White	Lighting																					

# SSL - Discrete Wire IDC Contact & Cap

Series 9176-400

## CONTACT DETAILS

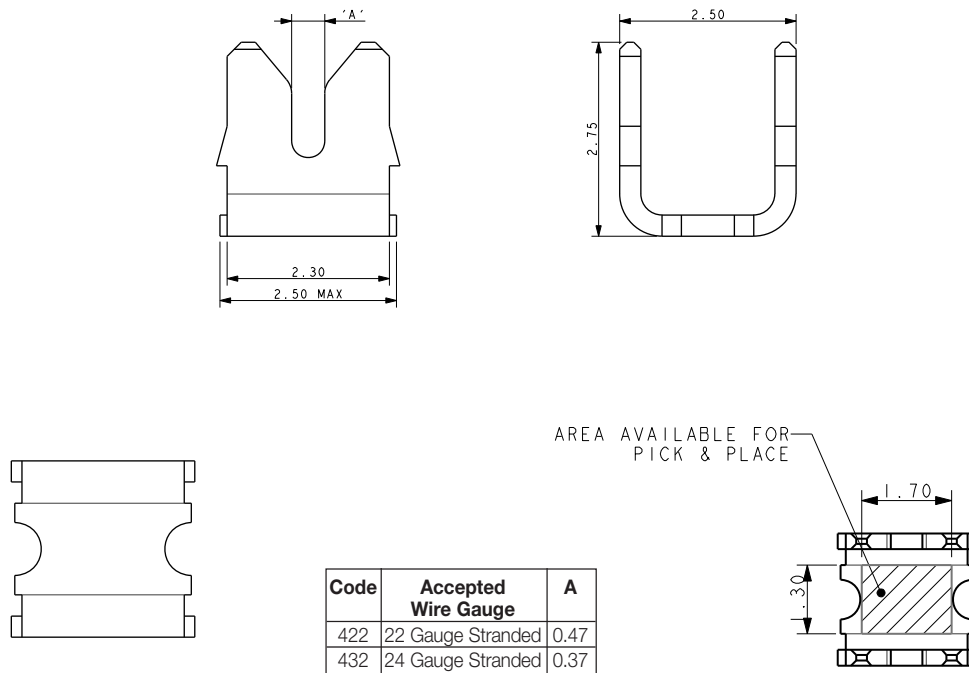

### NOTES:

1. CONNECTOR FOR IDC WIRE TO BOARD CONNECTION.
2. CONTACT MATERIAL: PHOSPHORE BRONZE.
3. CONTACT PLATING: PURE TIN.
4. CONNECTOR DESIGNED TO ACCEPT BETWEEN 22 AND 24 GAUGE STRANDED WIRE. SEE TABLE.
5. ALL DIMENSIONS FOR REFERENCE UNLESS OTHERWISE STATED.
6. FOR FULL PRODUCT SPECIFICATION REFER TO ELCO SPEC 201-01-106 AND APPLICATION NOTES 201-01-124.
7. SMT PCB LAYOUT, REFER TO PAGE 53.
8. PACKING IN TAPE AND REEL, QUANTITY 2000 PER REEL.
9. WHEN REQUIRED, MATCHING CAP DETAILS ON DRAWING 60-9176-001-4XX-X06S.
10. ASSEMBLY TOOLING ON PAGE 54 FOR WIRE INTO CONTACT.

## PACKING DETAILS

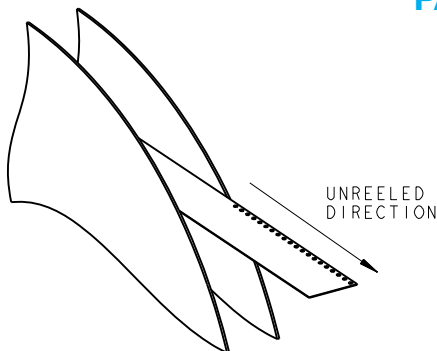

REEL QTY	1000
LEADER	480MM
TRAILER	120MM

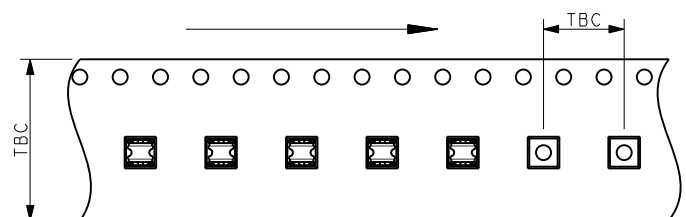

# SSL - Discrete Wire IDC Contact & Cap **AVX**

Series 9176-400

## 22-24 AWG IDC WIRE TO BOARD CONNECTOR SINGLE CONTACT

### SMT PCB LAYOUT

PURE TIN PADS

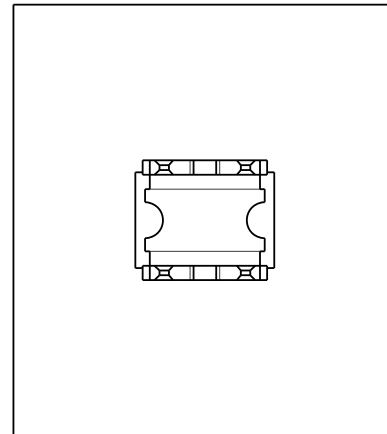
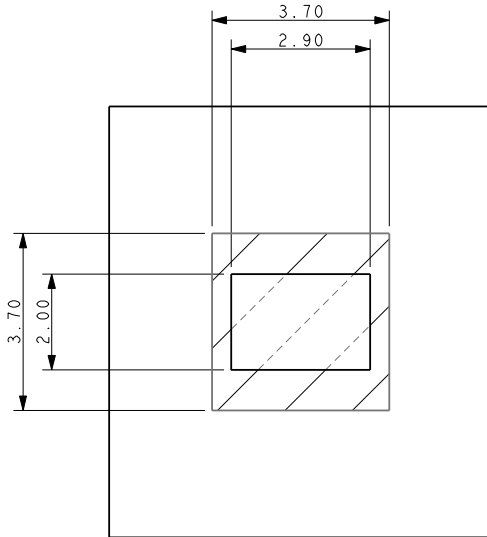

ORIENTATION OF CONTACT ON PAD

### ASSEMBLED/INSTALLED PRODUCTS

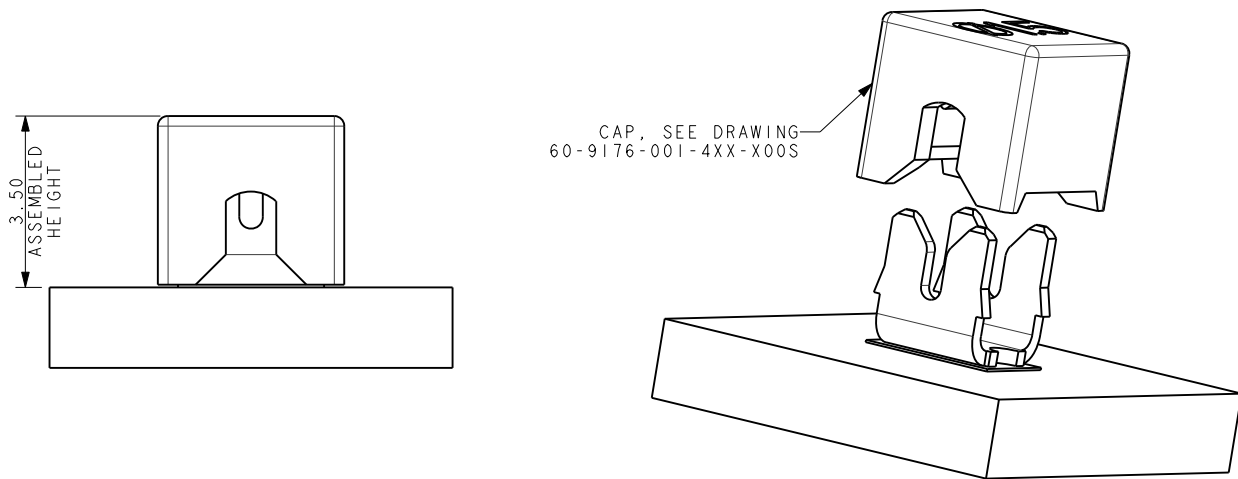

#### NOTES:

1. CONNECTOR CAN BE USED WITH CONTACT ONLY OR WITH OPTIONAL CAP.
2. OUTLINE OF CAP WHEN USED.
3. FOR FULL PRODUCT SPECIFICATION REFER TO ELCO SPEC 201-01-106 AND APPLICATION NOTES 201-01-124.
4. DIMENSIONS SHOWN ARE REFERENCED DIMENSIONS.
5. ASSEMBLY TOOLING FOR WIRE INTO CONTACT SEE PAGE 54.

# SSL - Discrete Wire IDC Contact & Cap

Series 9176-400

## ASSEMBLY TOOLING – CAP NOT USED WIRE ONTO CONTACT

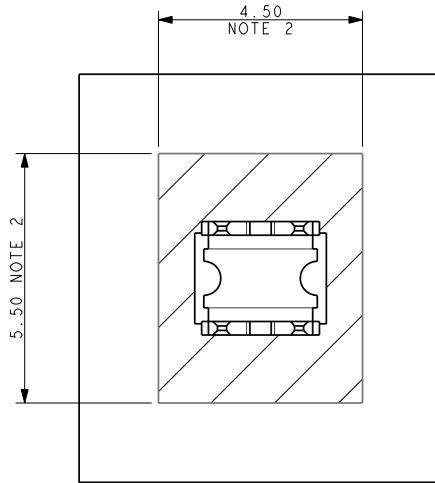

**NOTES:**

1. ASSEMBLY TOOLING FOR CONTACT ONLY, NO CAP USED.
2. MINIMUM AREA OF PCB TO BE KEPT CLEAR OF COMPONENTS, TACKS PERMISSIBLE.
3. REFER TO APPLICATION NOTE 201-01-124 FOR FURTHER INFORMATION.
4. INSERT CORRECT TOOL INTO HANDLE, MAGNETIC RETENTION .

### METAL TOOL – HIGH VOLUME

06-9176-7021-01-000

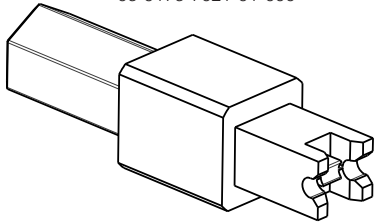

### PLASTIC TOOL – LOW/MEDIUM VOLUME

06-9176-7022-01-000

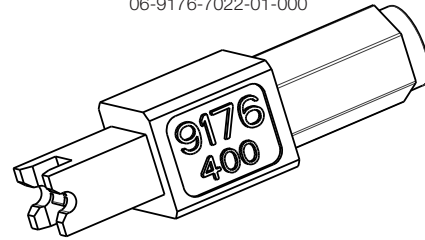

### UNIVERSAL HANDLE

06 7000 7730 01 000

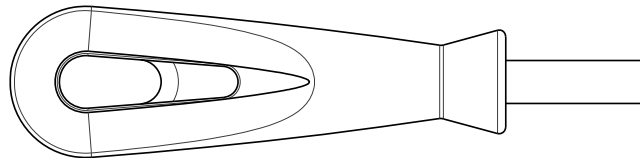

# SSL - Discrete Wire IDC Contact & Cap

Series 9176-400

## CAP DETAILS

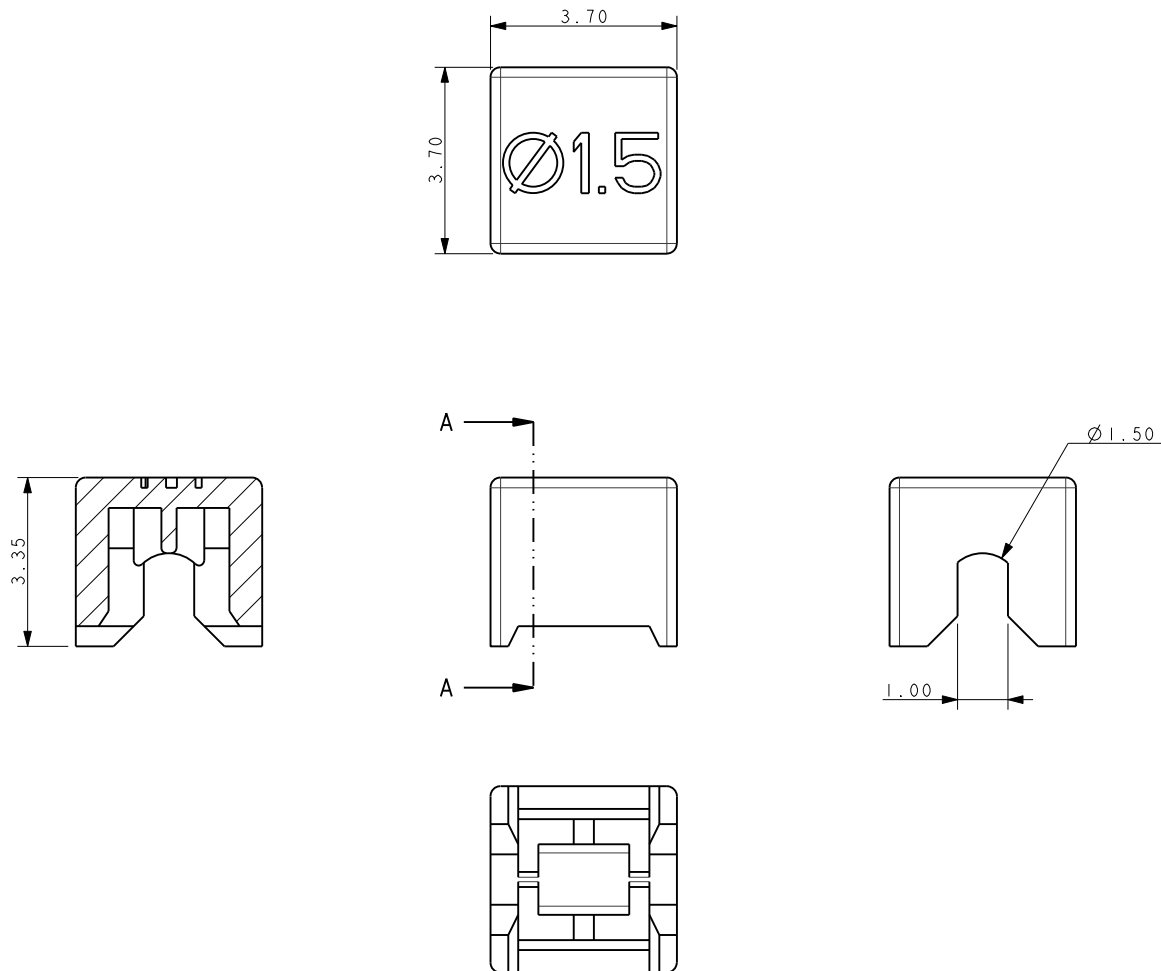

### NOTES:

1. CAP FOR IDC WIRE TO BOARD CONNECTION.
2. CAP MATERIAL: GLASS FILLED NYLON 46, COLOR SEE PAGE 51.
3. CAPS DESIGNED TO ACCOMMODATE WIRE INSULATION DIAMETERS 1.0MM TO 1.5MM.
4. ALL DIMENSIONS FOR REFERENCE UNLESS OTHERWISE STATED.
5. FOR FULL PRODUCT SPECIFICATION REFER TO ELCO SPEC 201-01-106, APPLICATION NOTES 201-01-124.
6. PACKING IN BAGS, QUANTITY 2000 PER BAG.
7. FOR INSTALATION DETAILS REFER TO DRAWING 70-9176-001-4XX-006S.

Компания «Океан Электроники» предлагает заключение долгосрочных отношений при поставках импортных электронных компонентов на взаимовыгодных условиях!

Наши преимущества:

- Поставка оригинальных импортных электронных компонентов напрямую с производств Америки, Европы и Азии, а так же с крупнейших складов мира;
- Широкая линейка поставок активных и пассивных импортных электронных компонентов (более 30 млн. наименований);
- Поставка сложных, дефицитных, либо снятых с производства позиций;
- Оперативные сроки поставки под заказ (от 5 рабочих дней);
- Экспресс доставка в любую точку России;
- Помощь Конструкторского Отдела и консультации квалифицированных инженеров;
- Техническая поддержка проекта, помощь в подборе аналогов, поставка прототипов;
- Поставка электронных компонентов под контролем ВП;
- Система менеджмента качества сертифицирована по Международному стандарту ISO 9001;
- При необходимости вся продукция военного и аэрокосмического назначения проходит испытания и сертификацию в лаборатории (по согласованию с заказчиком);
- Поставка специализированных компонентов военного и аэрокосмического уровня качества (Xilinx, Altera, Analog Devices, Intersil, Interpoint, Microsemi, Actel, Aeroflex, Peregrine, VPT, Syfer, Eurofarad, Texas Instruments, MS Kennedy, Miteq, Cobham, E2V, MA-COM, Hittite, Mini-Circuits, General Dynamics и др.);

Компания «Океан Электроники» является официальным дистрибьютором и эксклюзивным представителем в России одного из крупнейших производителей разъемов военного и аэрокосмического назначения «JONHON», а так же официальным дистрибьютором и эксклюзивным представителем в России производителя высокотехнологичных и надежных решений для передачи СВЧ сигналов «FORSTAR».



## JONHON

«JONHON» (основан в 1970 г.)

Разъемы специального, военного и аэрокосмического назначения:

(Применяются в военной, авиационной, аэрокосмической, морской, железнодорожной, горно- и нефтедобывающей отраслях промышленности)

«FORSTAR» (основан в 1998 г.)

ВЧ соединители, коаксиальные кабели, кабельные сборки и микроволновые компоненты:

(Применяются в телекоммуникациях гражданского и специального назначения, в средствах связи, РЛС, а так же военной, авиационной и аэрокосмической отраслях промышленности).



Телефон: 8 (812) 309-75-97 (многоканальный)

Факс: 8 (812) 320-03-32

Электронная почта: [ocean@oceanchips.ru](mailto:ocean@oceanchips.ru)

Web: <http://oceanchips.ru/>

Адрес: 198099, г. Санкт-Петербург, ул. Калинина, д. 2, корп. 4, лит. А