

EAO – Your Expert Partner for
Human Machine Interfaces

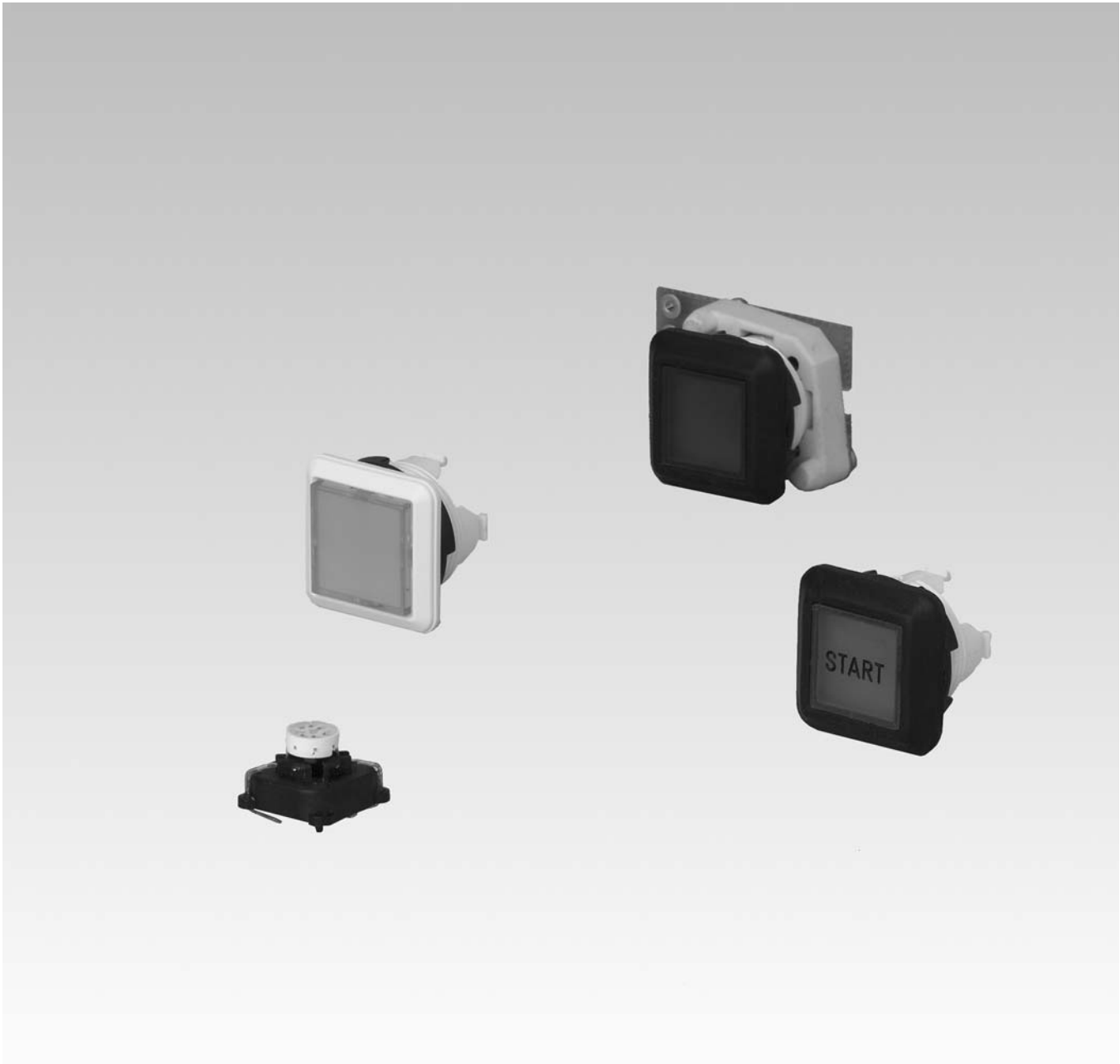

EAO Product Information

Series 92



Description	3
Product Assembly	4
Mounting instruction	6
PCB Pushbuttons	7
Accessories.....	10
Spare Parts	13
Technical Data.....	15
Application guidelines.....	16
Marking	17
Drawings.....	18
Index.....	22

Product Information

General notes

With the series 92, users have a comprehensive range of applications at their disposal in the PCB key range. In particular, this series is an interesting alternative to the membrane switching system, because it offers convincing advantages, such as: Saving on initial costs, short manufacturing times, all-over illumination and a reliable and nevertheless removable PCB fastening technology.

With the series 92, many different applications are possible even as a discrete switch.

Thanks to front sealing IP 67, and the use of chemical-resistant materials, the elements of this series are suited for industrial use.

The actuator, measuring 18.8 x 18.8 mm at the front (18.8 x 18.4 mm IP 40), is available as an indicator, pushbutton or illuminated pushbutton in marked or unmarked versions.

In order to have matching colours, the actuator element can be supplied with different colours. The switching element complies with international protection level IP 40 and is solder-proof on the connection side. The specially formed connection legs prevent it from falling out when using flow soldering.

Mounting

The actuators of the series 92 are made for the standard 16 mm dia. mounting hole and fastened tightly to the front panel by means of a fixing nut. Mounting torque max. 50 Ncm.

The switching element is mounted on the printed board independently of the actuator. The arrangement of contacts is based on the matrix dimension 2.54 mm (1/10"). By means of the mounting flange, the PCB can be snapped on the pre-assembled actuator. Later adjustment is no longer necessary. The mounting flange is fastened to the PCB with two 1.8 mm dia. screws, also independent of the actuator. The positioning and the number of flanges is determined by the size of the front panel or PCB.

The actuators are protected against distortion.

Lenses

The flat front bezel with integrated pressure plate, made of UV resistant TPE has a black finish (standard). Colour variations enable the manufacture of transparent pressure plates of different colours.

Marking

For further information about hot stamping, laser marking and film inserts see part Marking.

Illumination

Perfect illumination of the touch surfaces available in various colours is assured by the LEDs Bi-Pin T1 in the colours blue, yellow, green, orange, red and white.

Luminosity and wave length scattering caused by the technology used in the LED manufacturing processes may lead to visual differences in our products.

Cleaning of soldered PCB

PCBs are often cleaned after machine soldering. When doing this, care must be taken to prevent the "cleaning fluid" polluted with dirt, grease and flux from penetrating the switch.

Specimen order

Illuminated pushbutton :

- Illuminated pushbutton actuator, IP 40, front-ring black, lens yellow 92-458.400

Essential accessories :

- Switching element illuminative 92-851.342
- Single-LED T1 Bi-Pin, yellow 10-2602.3174D
- Mounting flange 92-960.0

We reserve the right to modify technical data

All dimensions in mm

Indicator IP 40

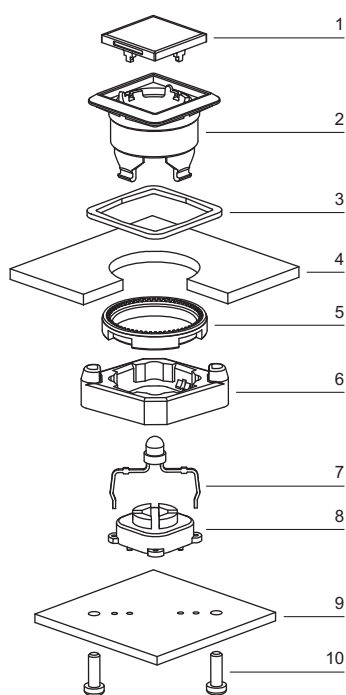

- 1 Lens
- 2 Actuator housing
- 3 Switch housing
- 4 Front plate
- 5 Fixing nut
- 6 Mounting flange
- 7 LED
- 8 Switching element
- 9 Printed circuit board
- 10 Fixing screws

Illuminated pushbutton IP 67

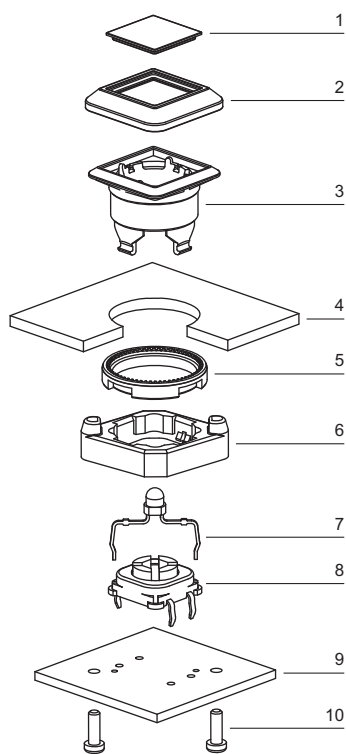

- 1 Lens
- 2 Front bezel
- 3 Actuator housing
- 4 Front plate
- 5 Fixing nut
- 6 Mounting flange
- 7 LED
- 8 Switching element
- 9 Printed circuit board
- 10 Fixing screws

Pushbutton IP 40

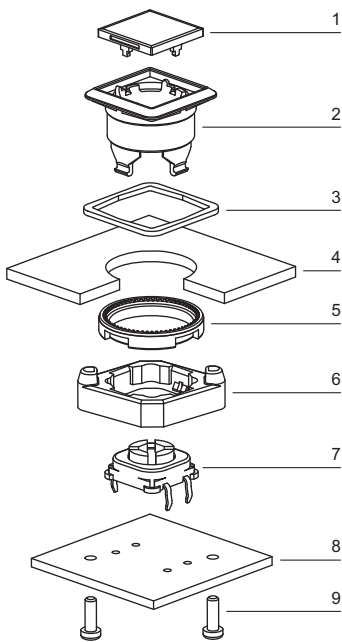

- 1 Lens
- 2 Actuator housing
- 3 Bezel
- 4 Front plate
- 5 Fixing nut
- 6 Mounting flange
- 7 Switching element
- 8 Printed circuit board
- 9 Fixing screws

Arrangement mounting flange

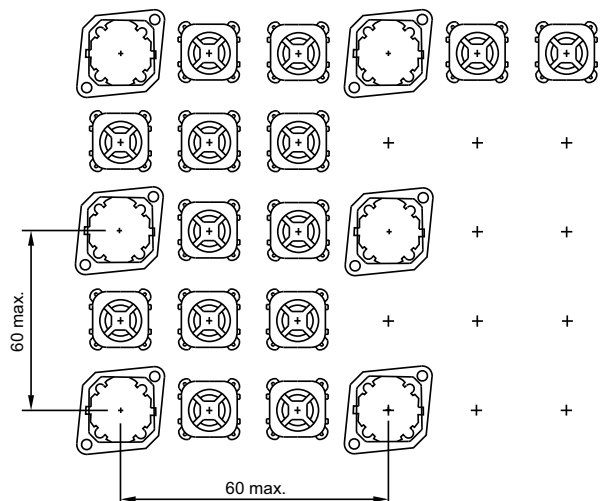

The arrangement of the mounting flanges and their number is determined by the size of the front panel or PCB. To ensure uniform, tactile switching, we recommend a layout of the flanges as per adjacent sketch.

For large PCBs with several switching elements we recommend the following procedure :

1. Fit the actuator to the front panel.
2. Clip the mounting flange to the rear of the intended actuator.
3. Screw the PCB with the components soldered to it to the assembled mounting flange.

This arrangement applies to PCBs 1.6 mm thick.

Dismantling mounting flange

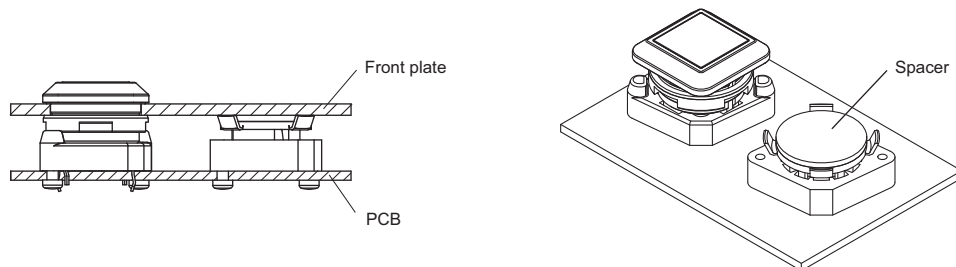

The tool 92-971.0 must be used for removing the mounting flange from the actuator. Before removing the flange, the PCB fixing screws must be loosened.

If the number of actuators is insufficient, use the spacer 92-965.0 which can be attached to the front panel.

The spacer can be adjusted to the following front panel thicknesses: 1.5/2.2/3/3.5/4 mm and can be stuck to the back of the panel free of dirt and grease.

Indicator actuator



Essential Accessories:

- Illumination element PCB mounting page 10
- Mounting flange page 12
- Single-LED page 11



Indicator actuator	Front protection	Front bezel	Lens	18.8 x 18.8 mm	18.4 x 18.4 mm	Mounting dimensions		Technical drawing
				Typ-Nr.	Typ-Nr.			
Indicator actuator	IP 67	Plastic black	Plastic blue transparent	92-143.600		1	7	0.003
			Plastic colourless transparent	92-143.700		1	7	0.003
			Plastic green transparent	92-143.500		1	7	0.003
			Plastic orange transparent	92-143.300		1	7	0.003
			Plastic red transparent	92-143.200		1	7	0.003
			Plastic yellow transparent	92-143.400		1	7	0.003
		Plastic white	Plastic blue transparent	92-043.600		1	7	0.003
			Plastic colourless transparent	92-043.700		1	7	0.003
			Plastic green transparent	92-043.500		1	7	0.003
			Plastic orange transparent	92-043.300		1	7	0.003
			Plastic red transparent	92-043.200		1	7	0.003
			Plastic yellow transparent	92-043.400		1	7	0.003
	IP 40	Plastic black	Plastic blue transparent		92-158.600	1	4	0.003
			Plastic colourless transparent		92-158.700	1	4	0.003
			Plastic green transparent		92-158.500	1	4	0.003
			Plastic orange transparent		92-158.300	1	4	0.003
			Plastic red transparent		92-158.200	1	4	0.003
			Plastic smoked transparent		92-158.100	1	4	0.003
		Plastic white	Plastic blue transparent		92-058.600	1	4	0.003
			Plastic colourless transparent		92-058.700	1	4	0.003
			Plastic green transparent		92-058.500	1	4	0.003
			Plastic orange transparent		92-058.300	1	4	0.003
			Plastic red transparent		92-058.200	1	4	0.003
			Plastic smoked transparent		92-058.100	1	4	0.003
		Plastic yellow transparent		92-058.400	1	4	0.003	

Mounting dimensions from page 18, Technical drawing from page 19

Pushbutton actuator



Essential Accessories:

-  Mounting flange page 12
-  Switching element PCB mounting illuminative page 10

	Front protection	Front bezel	Lens	∅ 18.8 x 18.8 mm Typ-Nr.	∅ 18.4 x 18.4 mm Typ-Nr.	Mounting dimensions	Technical drawing	Circuit drawing	
Pushbutton actuator	IP 67	Plastic black	Plastic black opaque	92-441.000		1	8	1	0.002
			Plastic grey opaque	92-441.800		1	8	1	0.002
		Plastic white	Plastic black opaque	92-341.000		1	8	1	0.002
			Plastic grey opaque	92-341.800		1	8	1	0.002
	IP 40	Plastic black	Plastic black opaque		92-456.000	1	5	1	0.002
			Plastic grey opaque		92-456.800	1	5	1	0.002
			Plastic white opaque		92-456.900	1	5	1	0.002
		Plastic white	Plastic black opaque		92-356.000	1	5	1	0.002
			Plastic grey opaque		92-356.800	1	5	1	0.002
			Plastic white opaque		92-356.900	1	5	1	0.002

Mounting dimensions from page 18, Technical drawing from page 19, Circuit drawing from page 21

Illuminated pushbutton actuator



Essential Accessories:

- Mounting flange page 12
- Single-LED page 11
- Switching element PCB mounting illuminative page 10

	Front protection	Front bezel	Lens	∅ 18.8 x 18.8 mm Typ-Nr.	∅ 18.4 x 18.4 mm Typ-Nr.	Mounting dimensions			
						Technical drawing	Circuit drawing		
Illuminated pushbutton actuator	IP 67	Plastic black	Plastic blue transparent	92-443.600		1	3	1	0.003
			Plastic colourless transparent	92-443.700		1	3	1	0.003
			Plastic green transparent	92-443.500		1	3	1	0.003
			Plastic orange transparent	92-443.300		1	3	1	0.003
			Plastic red transparent	92-443.200		1	3	1	0.003
			Plastic yellow transparent	92-443.400		1	3	1	0.003
		Plastic white	Plastic blue transparent	92-343.600		1	3	1	0.003
			Plastic colourless transparent	92-343.700		1	3	1	0.003
			Plastic green transparent	92-343.500		1	3	1	0.003
			Plastic orange transparent	92-343.300		1	3	1	0.003
			Plastic red transparent	92-343.200		1	3	1	0.003
			Plastic yellow transparent	92-343.400		1	3	1	0.003
	IP 40	Plastic black	Plastic blue transparent		92-458.600	1	6	1	0.003
			Plastic colourless transparent		92-458.700	1	6	1	0.003
			Plastic green transparent		92-458.500	1	6	1	0.003
			Plastic orange transparent		92-458.300	1	6	1	0.003
			Plastic red transparent		92-458.200	1	6	1	0.003
			Plastic smoked transparent		92-458.100	1	6	1	0.003
		Plastic white	Plastic blue transparent		92-358.600	1	6	1	0.003
			Plastic colourless transparent		92-358.700	1	6	1	0.003
			Plastic green transparent		92-358.500	1	6	1	0.003
			Plastic orange transparent		92-358.300	1	6	1	0.003
			Plastic red transparent		92-358.200	1	6	1	0.003
			Plastic smoked transparent		92-358.100	1	6	1	0.003
		Plastic yellow transparent		92-358.400	1	6	1	0.003	

Mounting dimensions from page 18, Technical drawing from page 19, Circuit drawing from page 21

Front

Blind plug

		Typ-Nr.	Mounting dimensions	
	Blind plug	∅ 18 x 18 mm Typ-Nr.		
Blind plug	Plastic black	51-948.0	1	0.003



Mounting dimensions from page 18

Backside

Illumination element PCB mounting

The customer has to decide what series resistor shall be used to the LED

	Terminals	Typ-Nr.	Component layout	Technical drawing	
Illumination element PCB mounting	P	92-800.042	1	1	0.001



Illumination and mounting flange to be ordered separately.

Terminals: P = PCB terminal

Component layout from page 18, Technical drawing from page 19

Switching element PCB mounting illuminative

The customer has to decide what series resistor shall be used to the LED

	Terminals	Typ-Nr.	Component layout	Technical drawing	Circuit drawing	
Switching element PCB mounting illuminative	P	92-851.342	2	9	2	0.001



Illumination and mounting flange to be ordered separately.

Terminals: P = PCB terminal

Component layout from page 18, Technical drawing from page 19, Circuit drawing from page 21

Spacer

	Typ-Nr.	
Spacer	92-965.0	0.003



When fitting, ensure that back of panel is free of grease and dirt

PCB assembled

	Typ-Nr.	
PCB assembled for discrete switching applications including switching element and mounting flange, soldering terminal (assembled PCB incl. series resistor and LED on request)	92-981.0	0.003



Illumination

Single-LED

The customer has to decide what series resistor shall be used to the LED

	Socket	Operating voltage/-current	Light colour	Typ-Nr.	
Single-LED	T1 Bi-Pin	2.1 VDC, 20 mA	orange	10-2602.3203L	0.001
			red	10-2602.3202L	0.001
		3.5 VDC, 20 mA	yellow	10-2602.3174D	0.001
			blue	10-2602.3206L	0.001
			green	10-2602.3205L	0.001
			white	10-2602.3209L	0.001



Bi-colour LED

The customer has to decide what series resistor shall be used to the LED

	Socket	Light colour	Operating voltage/-current	Typ-Nr.	
Bi-colour LED	T1 Bi-Pin	red/green	1.9/3.5 VDC, 20 mA	10-2603.320AL	0.001
		yellow/green	2.0/3.2 VDC, 20 mA	10-2603.320CL	0.001



Multi-LED

The customer has to decide what series resistor shall be used to the LED

	Socket	Operating voltage/-current	Light colour	Typ-Nr.	
Multi-LED	T1 Bi-Pin	12 VDC, 40 mA	yellow	10-5609.3174D	0.001



Assembling

Anti-twist ring

for front panel thickness max. 2 mm

	Typ-Nr.	
Anti-twist ring Mounting hole size 16 mm dia.	51-910	0.001



Mounting flange

	Typ-Nr.	Technical drawing	
Mounting flange	92-960.0	2	0.001



Technical drawing from page 19

Lens remover

	Typ-Nr.	
Lens remover for lens plate IP 40 only	18-910	0.002



Mounting tool

	Typ-Nr.	
Mounting tool for Indicator 16 mm dia.	01-907	0.020



Dismantling tool

	Typ-Nr.	
Dismantling tool for actuator dismantling of switching- and illumination element and mounting flange	92-971.0	0.002



Pushbutton- and Illuminated pushbutton actuator IP 40

Pushbutton- and Illuminated pushbutton actuator IP 40

Lens and Front bezel order separately

	Front ring	∅ 18.4 x 18.4 mm Typ-Nr.	
Pushbutton- and Illuminated pushbutton actuator IP 40	Plastic black	92-450.000	0.003
	Plastic white	92-350.000	0.003



Lens for pushbuttons and indicators IP 40

	Lens	∅ 18.4 x 18.4 mm Typ-Nr.	
Lens for pushbuttons and indicators IP 40 13.2 x 13.2 mm with white Marking plate	Plastic black opaque	92-956.000	0.001
	Plastic blue translucent	92-956.600	0.001
	Plastic blue transparent	92-958.600	0.001
	Plastic colourless transparent	92-958.700	0.001
	Plastic green translucent	92-956.500	0.001
	Plastic green transparent	92-958.500	0.001
	Plastic grey opaque	92-956.800	0.001
	Plastic orange translucent	92-956.300	0.001
	Plastic orange transparent	92-958.300	0.001
	Plastic red translucent	92-956.200	0.001
	Plastic red transparent	92-958.200	0.001
	Plastic smoked transparent	92-958.100	0.001
	Plastic white opaque	92-956.900	0.001
	Plastic yellow translucent	92-956.400	0.001
	Plastic yellow transparent	92-958.400	0.001



Front bezel for pushbuttons and indicators IP 40

	Front ring	∅ 18.4 x 18.4 mm Typ-Nr.	
Front bezel for pushbuttons and indicators IP 40	Plastic black	92-912.0	0.001
	Plastic white	92-912.9	0.001



Pushbutton- and Illuminated pushbutton actuator IP 67

Pushbutton- and Illuminated pushbutton actuator IP 67

Lens order separately

	Front ring	∅ 18.8 x 18.8 mm Typ-Nr.	
Pushbutton- and Illuminated pushbutton actuator IP 67	Plastic black	92-440.000	0.003
		92-340.000	0.003



Indicator actuator IP 67

Lens plate order separately

	Front ring	∅ 18.8 x 18.8 mm Typ-Nr.	 kg
Indicator actuator IP 67	Plastic black	92-140.000	0.003



Lens for pushbuttons and indicators IP 67

	Lens plate	∅ 18.8 x 18.8 mm Typ-Nr.	 kg
Lens for pushbuttons and indicators IP 67 12 x 12 mm	Plastic black flush opaque	92-941.000	0.001
	Plastic blue flush transparent	92-941.600	0.001
	Plastic colourless flush transparent	92-941.700	0.001
	Plastic green flush transparent	92-941.500	0.001
	Plastic grey flush opaque	92-941.800	0.001
	Plastic orange flush transparent	92-941.300	0.001
	Plastic red flush transparent	92-941.200	0.001
	Plastic yellow flush transparent	92-941.400	0.001



Pushbutton- and Illuminated pushbutton

Switching system

Short-travel switching system with 2 independent contact points and tactile operation.
Guarantees reliable switching even of very light loads.
Fitted with 1 normally open contact.

Material

Lens

Polycarbonate (PC)

Front bezel

Thermoplastic Elastomer (TPE)

Frame

Thermoplastic Polyester (PBT)

Material of contact

Gold (Au)

Switching element

Thermoplastic Polyester (PET, PBT) and Polyacetale (POM)

Actuator housing

Thermoplastic Polyester (PBT)

Mechanical characteristics

Tightening torque

Fixing screw 40 Ncm recommended
Fixing nut max. 50 Ncm

Actuating force

2.7 N \pm 1 N measured at the switching element
5 N measured at the lens

Actuating travel

Switching element 0.4 mm

Rebound time

\leq 1 ms

Resistance to heat of soldering

260 °C, 5 s, as per IEC 60068-2-20

Mechanical lifetime

\geq 1 Million operations as per IEC 60512-5-9a

Electrical characteristics

Contact resistance

Starting value (initial) \leq 100 m Ω as per IEC 60512-2-2b

Isolation resistance

\geq 10⁹ Ω between all terminals at 100 VDC, as per IEC 60512-2-3a

Electrical life

\geq 500 000 operations at 42 VDC, 50 mA as per IEC 60512-5-9c.
When attention is paid to the direction of current flow from terminal 3/4 to 1/2 the electrical life can be prolonged.

Electrostatic discharge (ESD)

15 kV

Switch rating

Switching voltage	min. 50 mV AC/DC max. 42 V AC/DC
Switching current	min. 10 μ A AC/DC max. 100 mA AC/DC
Power rating	max. 2 W

Electric strength

500 VAC, 50 Hz, 1 min, as per IEC 60512-2-4a

Environmental conditions

Storage temperature

-40 °C ... +80 °C

Operating temperature

-25 °C ... +70 °C

Front protection

Switching element IP 40 (fluxproof to DIN 41640 Part 84)
front IP 67 or IP 40

Shock resistance

\leq 50 g for 11 ms as per IEC 60512-4-6c

Vibration resistance

(sinusoidal)
10 g at 10-2000 Hz, amplitude 0.75 mm as per IEC 60512-4-6d

Suppressor circuits

When switching inductive loads such as relays, DC motors, and DC solenoids, it is always important to absorb surges (e.g. with a diode) to protect the contacts. When these inductive loads are switched off, a counter emf can severely damage switch contacts and greatly shorten lifetime.

Fig. 1 shows an inductive load with a free-wheeling diode connected in parallel. This free-wheeling diode provides a path for the inductor current to flow when the current is interrupted by the switch. Without this free-wheeling diode, the voltage across the coil will be limited only by dielectric breakdown voltages of the circuit or parasitic elements of the coil. This voltage can be kilovolts in amplitude even when nominal circuit voltages are low (e.g. 12 VDC) see Fig. 2.

The free-wheeling diode should be chosen so that the reverse breakdown voltage is greater than the voltage driving the inductive load. The DC blocking voltage (VR) of the free-wheeling diode can be found in the datasheet of a diode. The forward current should be equal or greater than the maximum current flowing through the load.

To get an efficient protection, the free-wheeling diode must be connected as close as possible to the inductive load!

Switching with inductive load
Fig. 1

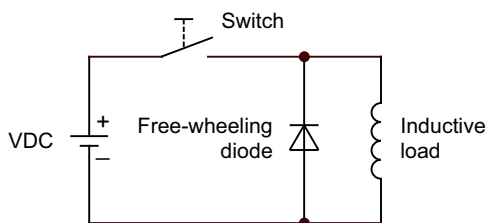

Counter emf
over load without free-wheeling diode
Fig. 2

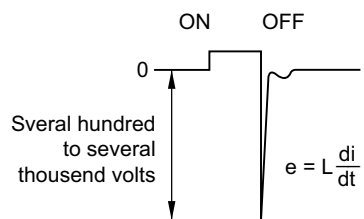

General notes

If desired, the actuators of the series 92 can be supplied ready marked. With your order please enclose a list of the desired markings or a drawing, showing the type or size of script or the symbols desired.

1. Laser engraving (Fig. 1)

In addition to the most commonly used world languages, in DIN 1451-3 close spacing, other typefaces are available as Scandinavian, Slavic, Greek, Russian and Polish.

Red, blue and black lenses are filled with white colour. Other colour lenses are filled in black. Standard height of letters is 2 mm. If the height is not specified, we will supply 2 mm engraved letters.

2. Hot stamping (Fig. 1)

For larger series it is worth considering markings by means of hot stamping. We will be pleased to advise you. For letters and figures, typefaces with 2.5 mm, 3 mm and 4 mm are available.

3. Film inserts (Fig. 2)

Instead of using engraving, the actuator can be fitted with transparent film inserts. However, for this purpose the use of transparent lens caps is recommended. If smoked lens caps are used the lettering does not become visible until the LED is alight. Max. size of film insert
11.4 x 11.4 mm for IP 40
10.4 x 10.4 mm for IP 67
Film thickness 0.2 mm.

All dimensions in mm

Height of letters h	Number of lines	Number of (target value) capital letters per line	Number of (target value) small letters per line
3	2	5 - 6	6
4	2	4	4
5	1	3	3 - 4
6	1	2 - 3	3
8	1	2	2

Fig. 1



Fig. 2

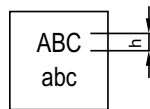
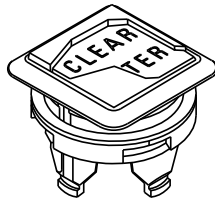

Component layout

1 Illumination element PCB mounting page 10

Single-LED

Drilling plan (Elementside)

- A Fixing holes for mounting flange (92-960.0)
- B Holes for LED
- C Holes for centering pins

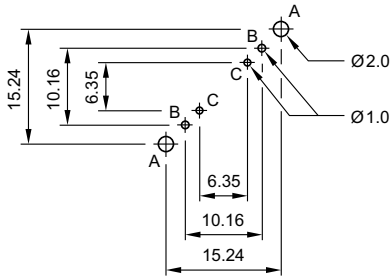

Bi-colour-LED

Drilling plan (Elementside)

- A Fixing holes for mounting flange (92-960.0)
- B Holes for Bi-colour LED:
BA1 (green) + BA2 (yellow or red) = Anodes, BC = Cathode
- C Holes for centering pins

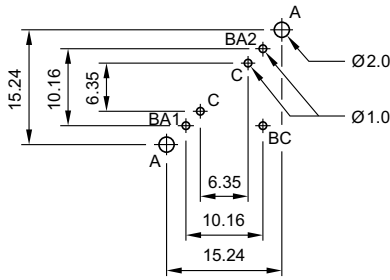

2 Switching element PCB mounting illuminative page 10

Single-LED

Drilling plan (Elementside)

- A Fixing holes for mounting flange (92-960.0)
- B Holes for LED
- C Holes for contact pins
Pad max. Ø 2.5 mm
Through-connection recommended

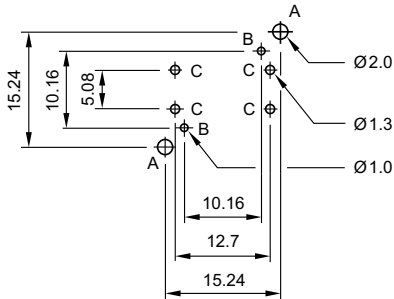

Bi-colour-LED

Drilling plan (Elementside)

- A Fixing holes for mounting flange (92-960.0)
- B Holes for Bi-colour LED:
BA1 (green) + BA2 (yellow or red) = Anodes, BK = Cathode
- C Holes for contact pins
Pad max. Ø 2.5 mm
Through-connection recommended

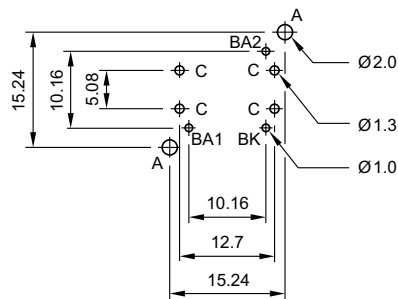

Mounting dimensions

1 Indicator actuator page 7 | Pushbutton actuator page 8 | Illuminated pushbutton actuator page 9 | Blind plug page 10

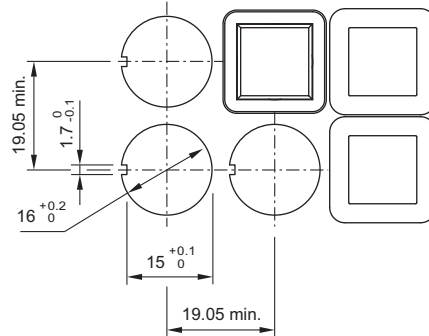
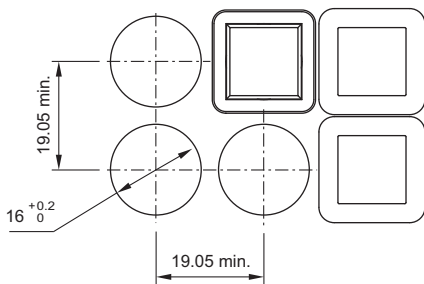

Technical drawing

1 Illumination element PCB mounting page 10

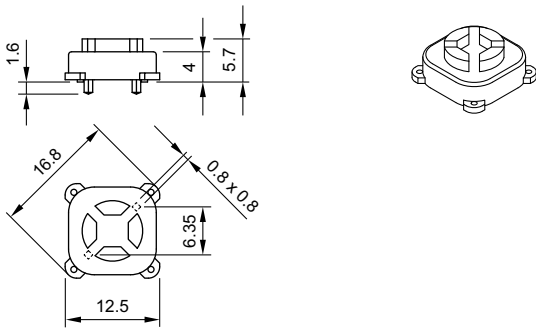

2 Mounting flange page 12

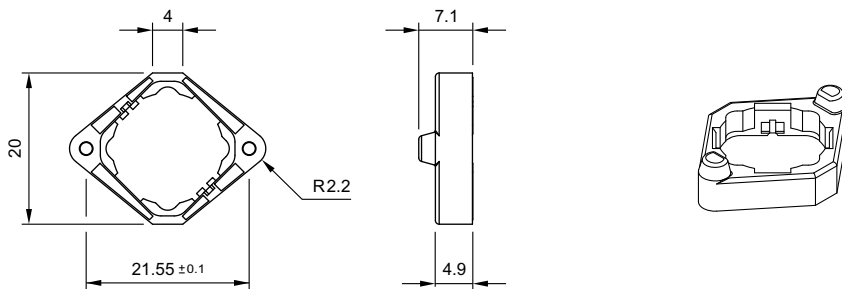

3 Illuminated pushbutton actuator page 9

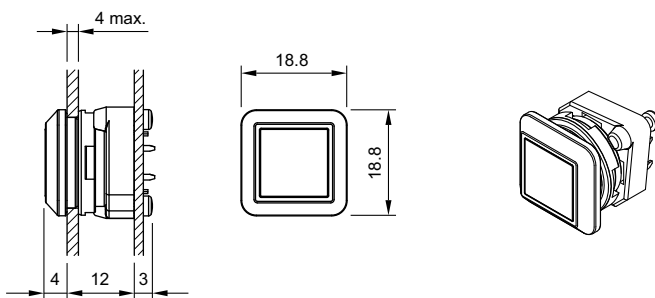

4 Indicator actuator page 7

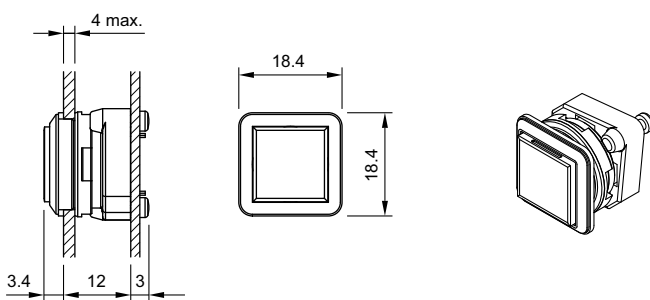

5 Pushbutton actuator page 8

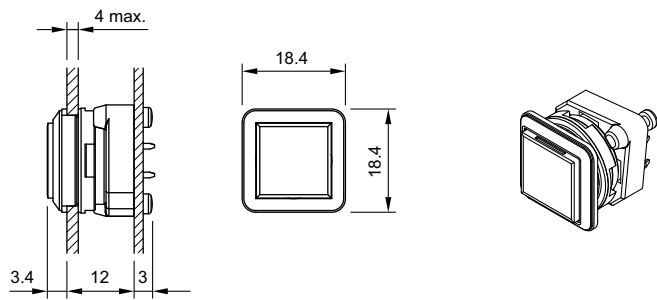

6 Illuminated pushbutton actuator page 9

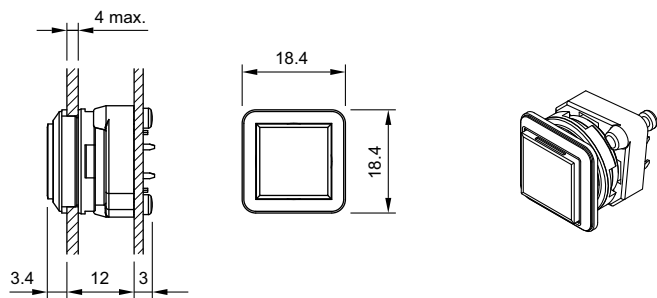

7 Indicator actuator page 7

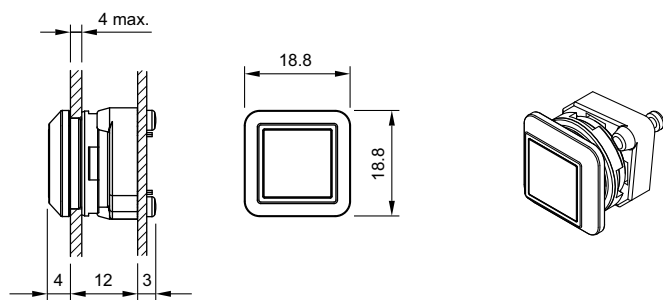

8 Pushbutton actuator page 8

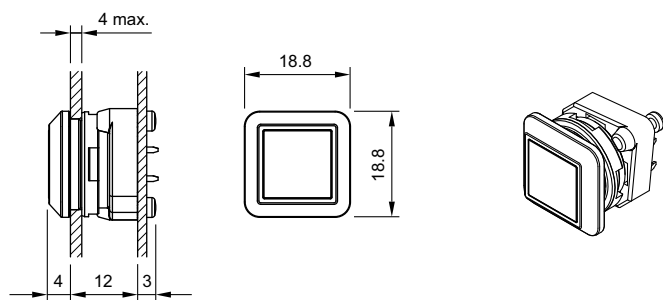

9 Switching element PCB mounting illuminative page 10

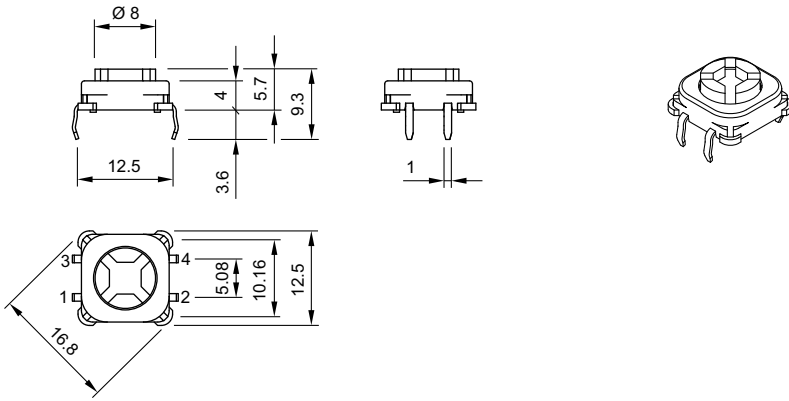

Circuit drawing

1 Pushbutton actuator page 8 | Illuminated pushbutton actuator page 9



2 Switching element PCB mounting illuminative page 10

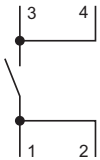

Index from Typ-Nr.

Typ-Nr.	Page	Typ-Nr.	Page	Typ-Nr.	Page
01-907	12	92-443.200	9		
10-2602.3174D	11	92-443.300	9		
10-2602.3202L	11	92-443.400	9		
10-2602.3203L	11	92-443.500	9		
10-2602.3205L	11	92-443.600	9		
10-2602.3206L	11	92-443.700	9		
10-2602.3209L	11	92-450.000	13		
10-2603.320AL	11	92-456.000	8		
10-2603.320CL	11	92-456.800	8		
10-5609.3174D	11	92-456.900	8		
18-910	12	92-458.100	9		
51-910	11	92-458.200	9		
51-948.0	10	92-458.300	9		
92-043.200	7	92-458.400	9		
92-043.300	7	92-458.500	9		
92-043.400	7	92-458.600	9		
92-043.500	7	92-458.700	9		
92-043.600	7	92-800.042	10		
92-043.700	7	92-851.342	10		
92-058.100	7	92-912.0	13		
92-058.200	7	92-912.9	13		
92-058.300	7	92-941.000	14		
92-058.400	7	92-941.200	14		
92-058.500	7	92-941.300	14		
92-058.600	7	92-941.400	14		
92-058.700	7	92-941.500	14		
92-140.000	14	92-941.600	14		
92-143.200	7	92-941.700	14		
92-143.300	7	92-941.800	14		
92-143.400	7	92-956.000	13		
92-143.500	7	92-956.200	13		
92-143.600	7	92-956.300	13		
92-143.700	7	92-956.400	13		
92-158.100	7	92-956.500	13		
92-158.200	7	92-956.600	13		
92-158.300	7	92-956.800	13		
92-158.400	7	92-956.900	13		
92-158.500	7	92-958.100	13		
92-158.600	7	92-958.200	13		
92-158.700	7	92-958.300	13		
92-340.000	13	92-958.400	13		
92-341.000	8	92-958.500	13		
92-341.800	8	92-958.600	13		
92-343.200	9	92-958.700	13		
92-343.300	9	92-960.0	12		
92-343.400	9	92-965.0	10		
92-343.500	9	92-971.0	12		
92-343.600	9	92-981.0	11		
92-343.700	9				
92-350.000	13				
92-356.000	8				
92-356.800	8				
92-356.900	8				
92-358.100	9				
92-358.200	9				
92-358.300	9				
92-358.400	9				
92-358.500	9				
92-358.600	9				
92-358.700	9				
92-440.000	13				
92-441.000	8				
92-441.800	8				

	EAO AG
	Tannwaldstrasse 88 4601 Olten, Switzerland
E-mail	info@eao.com
Website	www.eao.com
	Austria
Phone	+49 201 85 87 0
Fax	+49 201 85 87 210
E-mail	sales.ede@eao.com
	Belgium
Phone	+32 3 777 82 36
Fax	+32 3 777 84 19
E-mail	sales.ebl@eao.com
	China
Phone	+852 27 86 91 41
Fax	+852 27 86 95 61
E-mail	sales.ehk@eao.com
	France
Phone	+33 1 64 43 37 37
Fax	+33 1 64 43 37 49
E-mail	sales.esa@eao.com
	Germany
Phone	+49 201 85 87 0
Fax	+49 201 85 87 210
E-mail	sales.ede@eao.com
	Italy
Phone	+39 035 481 0189
Fax	+39 035 481 3786
E-mail	sales.eit@eao.com
	Japan
Phone	+81 3 5444 5411
Fax	+81 3 5444 0345
E-mail	sales.esj@eao.com
	Netherlands
Phone	+31 78 653 17 00
Fax	+31 78 653 17 99
E-mail	sales.enl@eao.com
	Sweden
Phone	+46 8 683 86 60
Fax	+46 8 724 29 12
E-mail	sales.esw@eao.com
	Switzerland
Phone	+41 62 388 95 00
Fax	+41 62 388 95 55
E-mail	sales.ech@eao.com
	United Kingdom
Phone	+44 1444 236 000
Fax	+44 1444 236 641
E-mail	sales.euk@eao.com
	USA
Phone	+1 203 877 4577
Fax	+1 203 877 3694
E-mail	sales.eus@eao.com
	Other Countries
Phone	+41 62 286 92 10
Fax	+41 62 296 21 62
E-mail	info@eao.com

Компания «Океан Электроники» предлагает заключение долгосрочных отношений при поставках импортных электронных компонентов на взаимовыгодных условиях!

Наши преимущества:

- Поставка оригинальных импортных электронных компонентов напрямую с производств Америки, Европы и Азии, а так же с крупнейших складов мира;
- Широкая линейка поставок активных и пассивных импортных электронных компонентов (более 30 млн. наименований);
- Поставка сложных, дефицитных, либо снятых с производства позиций;
- Оперативные сроки поставки под заказ (от 5 рабочих дней);
- Экспресс доставка в любую точку России;
- Помощь Конструкторского Отдела и консультации квалифицированных инженеров;
- Техническая поддержка проекта, помощь в подборе аналогов, поставка прототипов;
- Поставка электронных компонентов под контролем ВП;
- Система менеджмента качества сертифицирована по Международному стандарту ISO 9001;
- При необходимости вся продукция военного и аэрокосмического назначения проходит испытания и сертификацию в лаборатории (по согласованию с заказчиком);
- Поставка специализированных компонентов военного и аэрокосмического уровня качества (Xilinx, Altera, Analog Devices, Intersil, Interpoint, Microsemi, Actel, Aeroflex, Peregrine, VPT, Syfer, Eurofarad, Texas Instruments, MS Kennedy, Miteq, Cobham, E2V, MA-COM, Hittite, Mini-Circuits, General Dynamics и др.);

Компания «Океан Электроники» является официальным дистрибьютором и эксклюзивным представителем в России одного из крупнейших производителей разъемов военного и аэрокосмического назначения «JONHON», а так же официальным дистрибьютором и эксклюзивным представителем в России производителя высокотехнологичных и надежных решений для передачи СВЧ сигналов «FORSTAR».



JONHON

«JONHON» (основан в 1970 г.)

Разъемы специального, военного и аэрокосмического назначения:

(Применяются в военной, авиационной, аэрокосмической, морской, железнодорожной, горно- и нефтедобывающей отраслях промышленности)

«FORSTAR» (основан в 1998 г.)

ВЧ соединители, коаксиальные кабели, кабельные сборки и микроволновые компоненты:

(Применяются в телекоммуникациях гражданского и специального назначения, в средствах связи, РЛС, а так же военной, авиационной и аэрокосмической отраслях промышленности).



Телефон: 8 (812) 309-75-97 (многоканальный)

Факс: 8 (812) 320-03-32

Электронная почта: ocean@oceanchips.ru

Web: <http://oceanchips.ru/>

Адрес: 198099, г. Санкт-Петербург, ул. Калинина, д. 2, корп. 4, лит. А