

QUICK START GUIDE FOR DEMONSTRATION CIRCUIT 755

600KHZ, 1A SYNCHRONOUS BUCK-BOOST CONVERTER

LTC3443

DESCRIPTION

Demonstration Circuit 755 is a constant-frequency synchronous Buck-Boost converter using the LTC3443. The input range is from 2.4V to 5.5V, making it ideal for single-cell lithium-ion or three-cell NiCd/NiMH battery applications. This converter provides up to 95% efficiency, much higher than traditional Buck-Boost converters. For 2.5V minimum input voltage, this converter can provide up to 1A load current.

The output voltage is set at 3.3V. A different output voltage in the range of 2.4V to 5.25V can be obtained by changing one of the feedback resistors. The switching frequency is set at 600kHz, which is a good trade-off between efficiency and size. Applying twice the desired

frequency at the MODE/SYNC pin can also synchronize the switching frequency between 690kHz to 1.2MHz. In shutdown, the IC draws less than 1 μ A.

When using long wire connection to the input sources (such as wall adaptors), there can be input over voltage transients during initial plug-in. C8 is installed on DC755 to damp the possible voltage transients. C8 is not needed for any application when input source is close to the regulator. Please refer to Application Note 88 for details.

Design files for this circuit board are available. Call the LTC factory.

Table 1. Performance Summary ($T_A = 25^\circ\text{C}$ unless otherwise noted)

PARAMETER	CONDITION	VALUE
Minimum Input Voltage	-40°C to 85°C	2.4V (2.5V minimum input for 1A load)
Maximum Input Voltage	-40°C to 85°C	5.5V
Output Voltage V_{OUT}	$V_{IN} = 2.5\text{V to } 5.5\text{V}$, $I_{OUT} = 0\text{A to } 1\text{A}$	3.3V $\pm 4\%$
Maximum Output Current	$V_{IN} = 2.5\text{V}$	1A
Typical Output Ripple V_{OUT}	$V_{IN} = 3.0\text{V}$, $I_{OUT} = 1\text{A}$ (20MHz BW)	12mV _{PP} (measured at C5) 30mV _{PP} (measured across TP1 and TP2)
Typical Switching Frequency		600kHz
Efficiency (Fixed Frequency Mode)	$V_{IN} = 4.2\text{V}$, $I_{OUT} = 0.2\text{A}$ $V_{IN} = 4.2\text{V}$, $I_{OUT} = 1\text{A}$	95% Typical 91% Typical
On/Off Control	Off (40°C to 85°C) On (-40°C to 85°C)	0.4V MAX 1.4V MIN

QUICK START PROCEDURE

Demonstration circuit 755 is easy to set up to evaluate the performance of the LTC3443. Refer to Figure 1 for proper measurement equipment setup and follow the procedure below:

NOTE: When measuring the input or output voltage ripple, care must be taken to avoid a long ground lead on the oscilloscope probe. Measure the input or output voltage ripple by touching the probe tip directly across the Vin or Vout and GND terminals. See Figure 2 for proper scope probe technique.

1. Place jumpers in the following positions:

JP1 RUN
JP2 FIXED FREQ.

2. With power off, connect the input power supply to Vin and GND.

3. Turn on the power at the input.

NOTE: Make sure that the input voltage does not exceed 5.5V.

4. Check for the proper output voltage. Vout = 3.17V to 3.43V.

NOTE: If there is no output, temporarily disconnect the load to make sure that the load is not set too high.

5. Once the proper output voltage is established, adjust the load within the operating range and observe the output voltage regulation, ripple voltage, efficiency and other parameters.

QUICK START GUIDE FOR DEMONSTRATION CIRCUIT 755 600KHZ, 1A SYNCHRONOUS BUCK-BOOST CONVERTER

GRAPHICS

Linear Tech. Corp.
Demo Circuit 755A Rev1

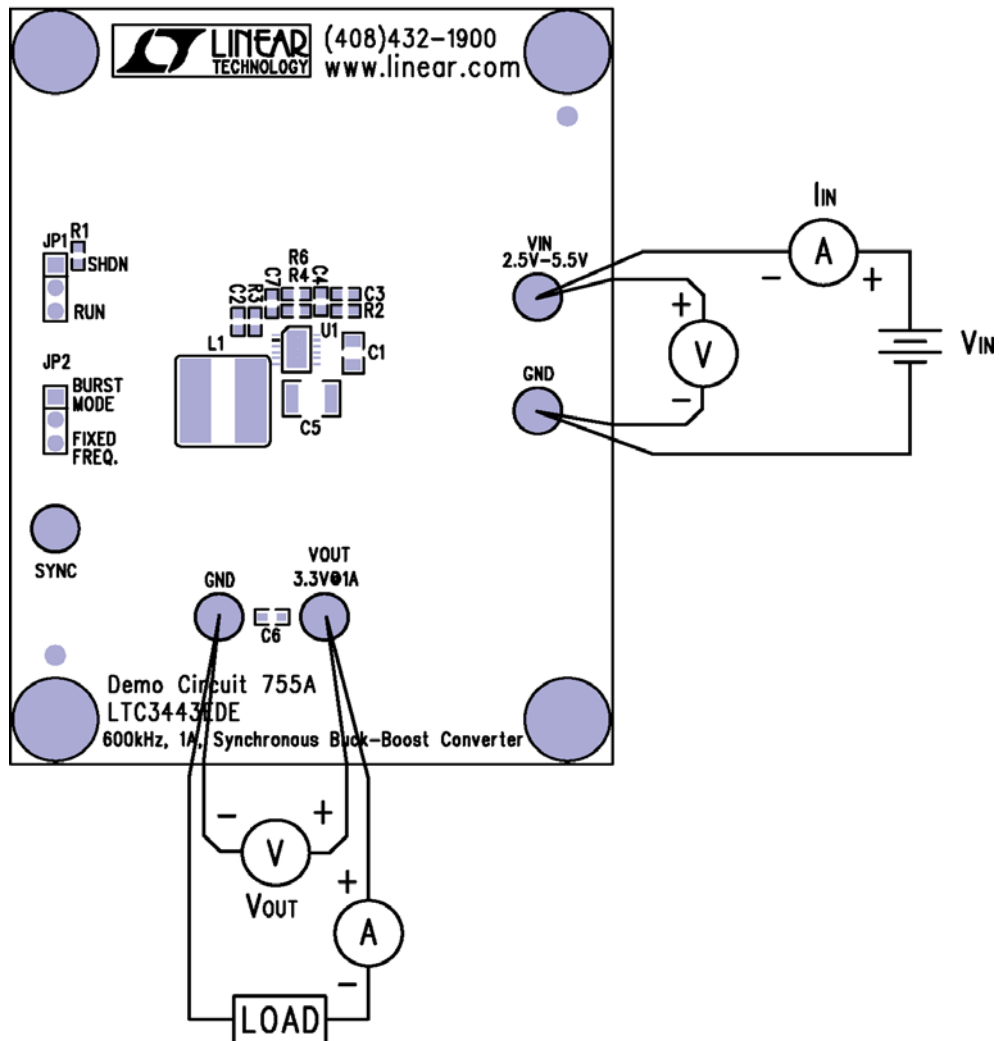

Figure 1. Proper Measurement Equipment Setup

QUICK START GUIDE FOR DEMONSTRATION CIRCUIT 755

600KHZ, 1A SYNCHRONOUS BUCK-BOOST CONVERTER

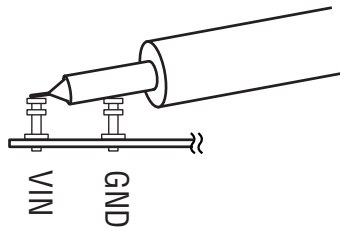

Figure 2. Measuring Input or Output Ripple

Efficiency vs. Load

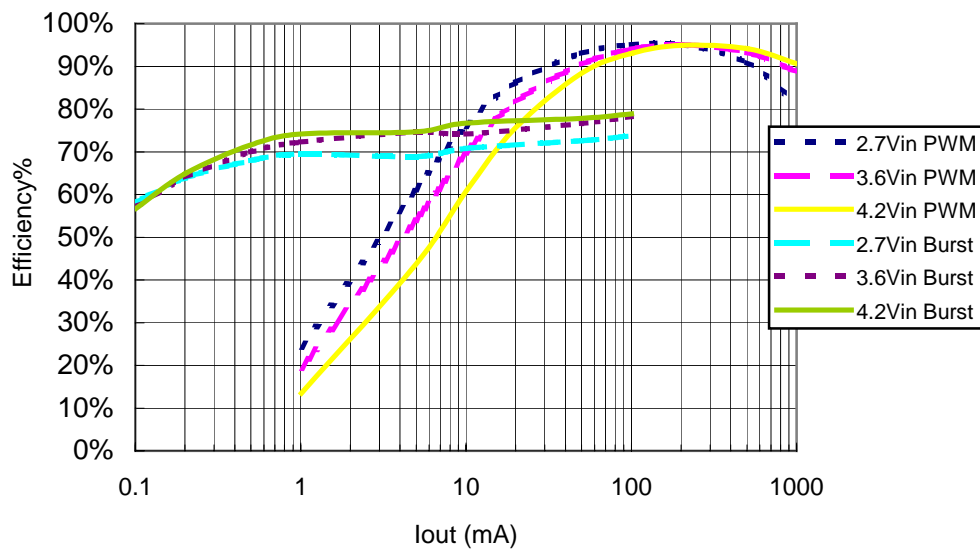

Figure 3. Efficiency of DC755

QUICK START GUIDE FOR DEMONSTRATION CIRCUIT 755

600KHZ, 1A SYNCHRONOUS BUCK-BOOST CONVERTER

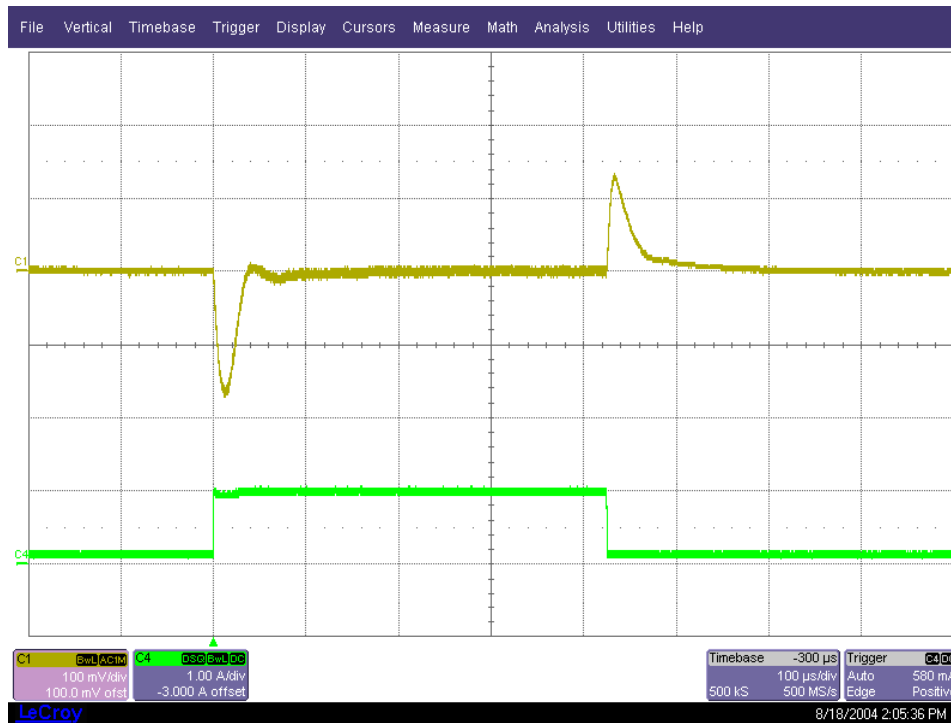
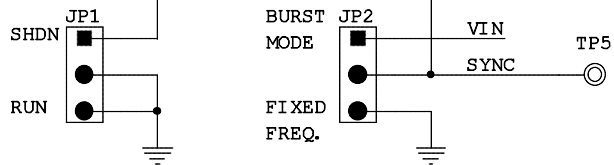
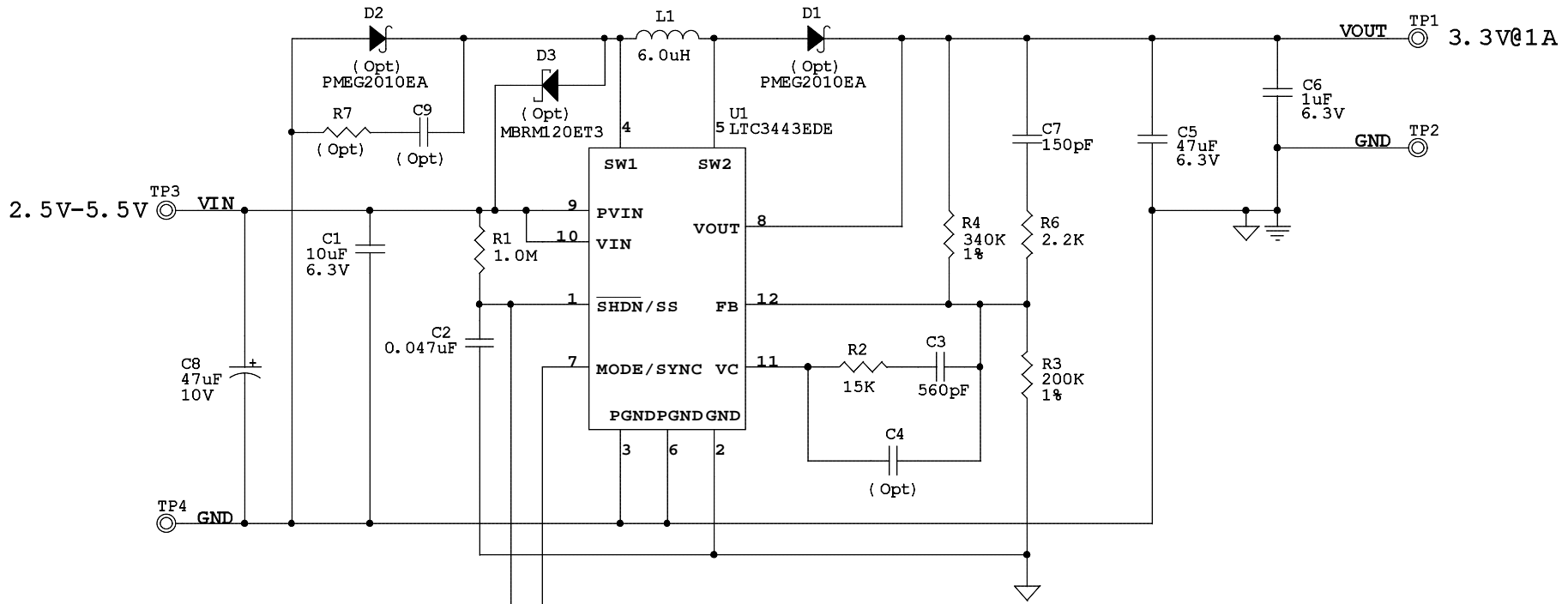
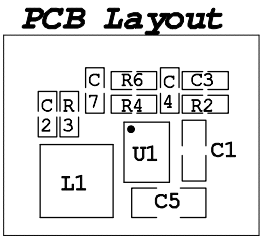

Figure 4. Load Transient Response ($V_{in}=3.3V$; Channel 1: V_{out} , 100mV/div; Channel4: I_{out} load step: 100mA to 1A)



NOTE:

1. Install D1 and D2 to improve efficiency.
2. D3 is recommended for Vin higher than 4.8Volts.



This circuit is proprietary to Linear Technology and supplied for use with Linear Technology parts.
Customer Notice: Linear Technology has made a best effort to design a circuit that meets customer-supplied specifications; however, it remains the customers responsibility to verify proper and reliable operation in the actual application, Component substitution and printed circuit board layout may significantly affect circuit performance or reliability. Contact Linear Applications Engineering for assistance.

Wednesday, August 18, 2004

1630 McCarthy Blvd., Milpitas, CA
 95035-7417
 Phone: (408)432-1900 Fax (408)434-0507

Linear Technology Corp.

Title 600kHz, 1A, Synchronous Buck-Boost Converter		
Size	Document Number DEMO CIRCUIT 755A	Rev 1
Date	Sheet 1 of 1	

Item	Qty	Reference	Part Description	Manufacture / Part #
1	1	C1	Cap., X5R 10uF 6.3V 20%	Taiyo Yuden JMK212BJ106MG-T
2	1	C2	Cap., X5R 0.047uF 16V 20%	AVX 0402YD473MAT2A
3	1	C3	Cap., X7R 560pF 16V 20%	AVX 0402YC561MAT2A
4	0	C4 (Opt)	Cap., NPO 10pF 25V 10%	AVX 04023A100KAT2A
5	1	C5	Cap., X5R 47uF 6.3V 20%	Taiyo Yuden JMK325BJ476MM-T
6	1	C6	Cap., X5R 1uF 6.3V 10%	Taiyo Yuden JMK107BJ105KA-T
7	1	C7	Cap., NPO 150pF 25V 5%	AVX 04023A151JAT2A
8	1	C8	Cap., Tant. 47uF 10V 20%	AVX TAJB476M010
9	0	C9 (Opt)	Cap., X7R 1000pF 25V 20%	AVX 04023C102MAT2A
10	2	D2,D1	Schottky Diodes, 1A/20V	Philips PMEG2010EA
11	1	D3	Schottky Diodes, 1A/20V	ON SEMI. MBRM120ET3
12	2	JP1,JP2	Headers, 3 Pins 2mm Ctrs.	CommConn Con Inc. 2802S-03G2
13	2	XJP1-XJP2	SHUNT, .079" CENTER	COMM-CON CCIJ2MM-138GW
14	1	L1	Inductor, 6.0uH	Sumida CDRH6D28-6R0NC
15	1	R1	Res., Chip 1.0M 1/16W 5%	AAC CR05-105JM
16	1	R2	Res., Chip 15K 1/16W 5%	AAC CR05-153JM
17	1	R3	Res., Chip 200K 0.06W 1%	AAC CR05-2003FM
18	1	R4	Res., Chip 340K 1/16W 1%	AAC CR05-3403FM
19	1	R6	Res., Chip 2.2K 0.06W 5%	AAC CR05-222JM
20	0	R7 (Opt)	Res., Chip 2.0 0.06W 1%	AAC CR05-2R00FM
22	1	U1	I.C., Buck Converter	Linear Tech. Corp. LTC3443EDE

Компания «Океан Электроники» предлагает заключение долгосрочных отношений при поставках импортных электронных компонентов на взаимовыгодных условиях!

Наши преимущества:

- Поставка оригинальных импортных электронных компонентов напрямую с производств Америки, Европы и Азии, а так же с крупнейших складов мира;
- Широкая линейка поставок активных и пассивных импортных электронных компонентов (более 30 млн. наименований);
- Поставка сложных, дефицитных, либо снятых с производства позиций;
- Оперативные сроки поставки под заказ (от 5 рабочих дней);
- Экспресс доставка в любую точку России;
- Помощь Конструкторского Отдела и консультации квалифицированных инженеров;
- Техническая поддержка проекта, помощь в подборе аналогов, поставка прототипов;
- Поставка электронных компонентов под контролем ВП;
- Система менеджмента качества сертифицирована по Международному стандарту ISO 9001;
- При необходимости вся продукция военного и аэрокосмического назначения проходит испытания и сертификацию в лаборатории (по согласованию с заказчиком);
- Поставка специализированных компонентов военного и аэрокосмического уровня качества (Xilinx, Altera, Analog Devices, Intersil, Interpoint, Microsemi, Actel, Aeroflex, Peregrine, VPT, Syfer, Eurofarad, Texas Instruments, MS Kennedy, Miteq, Cobham, E2V, MA-COM, Hittite, Mini-Circuits, General Dynamics и др.);

Компания «Океан Электроники» является официальным дистрибьютором и эксклюзивным представителем в России одного из крупнейших производителей разъемов военного и аэрокосмического назначения «JONHON», а так же официальным дистрибьютором и эксклюзивным представителем в России производителя высокотехнологичных и надежных решений для передачи СВЧ сигналов «FORSTAR».



JONHON

«JONHON» (основан в 1970 г.)

Разъемы специального, военного и аэрокосмического назначения:

(Применяются в военной, авиационной, аэрокосмической, морской, железнодорожной, горно- и нефтедобывающей отраслях промышленности)

«FORSTAR» (основан в 1998 г.)

ВЧ соединители, коаксиальные кабели,
кабельные сборки и микроволновые компоненты:

(Применяются в телекоммуникациях гражданского и специального назначения, в средствах связи, РЛС, а так же военной, авиационной и аэрокосмической отраслях промышленности).



Телефон: 8 (812) 309-75-97 (многоканальный)

Факс: 8 (812) 320-03-32

Электронная почта: ocean@oceanchips.ru

Web: <http://oceanchips.ru/>

Адрес: 198099, г. Санкт-Петербург, ул. Калинина, д. 2, корп. 4, лит. А