

Figure 1

1. INTRODUCTION

DAHT Adapter Assembly 1213563-1 is designed to accept the crimp head from any DAHT to adapt the crimp head for use with 626 pneumatic tooling assemblies. DAHTs are available from Tyco Electronics. For information concerning the setup and operation of the pneumatic tool, refer to Customer Manual 409-5862.

This instruction sheet provides:

- recommended procedures for crimp head removal from the hand tool
- crimp head installation into the adapter
- installation and removal of the cam and adapter from the pneumatic tool
- maintenance, inspection, and repair information for the adapter

For wire preparation and crimping procedure, and crimp head maintenance, inspection, and repair, refer to the associated instruction sheet.

Read these instructions thoroughly before proceeding.

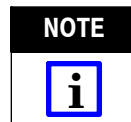

Dimensions are in millimeters [with inch equivalents in brackets]. Figures and illustrations are for identification only and are not drawn to scale.

Reasons for reissue of this instruction sheet are provided in Section 6, REVISION SUMMARY.

2. DESCRIPTION

The adapter assembly facilitates the connection of the crimp head (typical shown in Figure 1) to the pneumatic tool and provides the necessary motion of the crimp head jaws when the pneumatic tool is actuated. When the tool is actuated, the cam extends into the adapter, contacting the crimp head jaws. When the cam retracts, the force is removed from the jaws and they return to their starting position.

The jaws may be opened and closed manually by simultaneously squeezing the two opposing clevises, which are coupled to the jaws. The quick pins secure the crimp head to the adapter.

3. SET UP

3.1. Crimp Head Removal from Hand Tool

1. Remove the two retaining rings from one side of the hand tool body and push the retaining pins, along with the two remaining retaining rings, through the opposite side of the tool body as shown in Figure 2.
2. Slide the crimp head out of the tool body.

3.2. Crimp Head Installation onto Adapter

The adapter has two quick pins installed. The quick pins will be used to secure the crimp head to the adapter. Therefore, these quick pins must be removed prior to installing the crimp head, then proceed as follows:

1. Align the crimp head mounting holes with the adapter quick pin holes as shown in Figure 1, then insert the crimp head into adapter cavity.
2. Install the quick pins through the slotted holes in the adapter and into the crimp head mounting holes. See Figure 1.

NOTE *If quick pins become difficult to install, it may be necessary to jog the clevises to properly align the holes.*

DANGER *After the crimp head is installed, make sure that the quick pins are FULLY inserted to avoid personal injury and damage to the tool.*

3.3. Adapter Installation and Removal

After the crimp head has been installed onto the adapter, the adapter is ready for installation onto the pneumatic tool. Refer to Customer Manual 409-5862 for instructions on removing a previously installed cam and tool holder from the pneumatic tool.

DANGER *Air pressure must be removed from the pneumatic tool while crimp head or tool holder is detached.*

DANGER *DO NOT operate the pneumatic tool without the proper adapter and crimp head installed.*

1. If the adapter cam setscrew is not installed in the adapter cam, thread the setscrew into the adapter cam two to three turns.
2. Place the adapter cam (with setscrew) onto the piston rod of the pneumatic tool as shown in Figure 3. The adapter cam should butt against the piston rod face. If not, turn the setscrew counterclockwise until the adapter cam fits on the piston rod properly.

CAUTION *Over-tightening the adapter cam setscrew may damage the setscrew or cam.*

3. Using the hex wrench supplied with the adapter, tighten the cam setscrew, then pull on the cam to ensure that it is firmly attached.

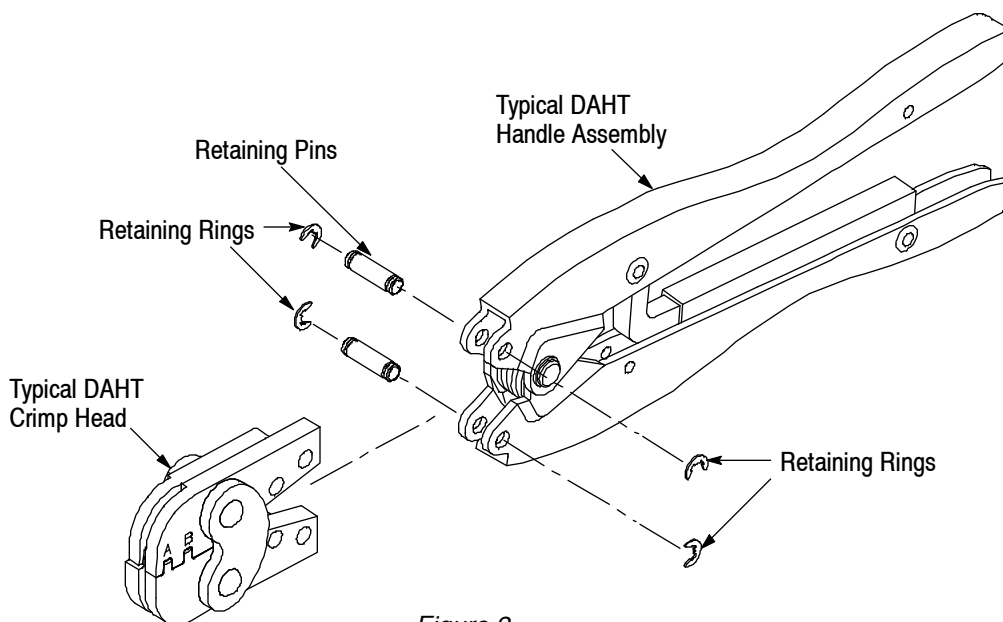

Figure 2

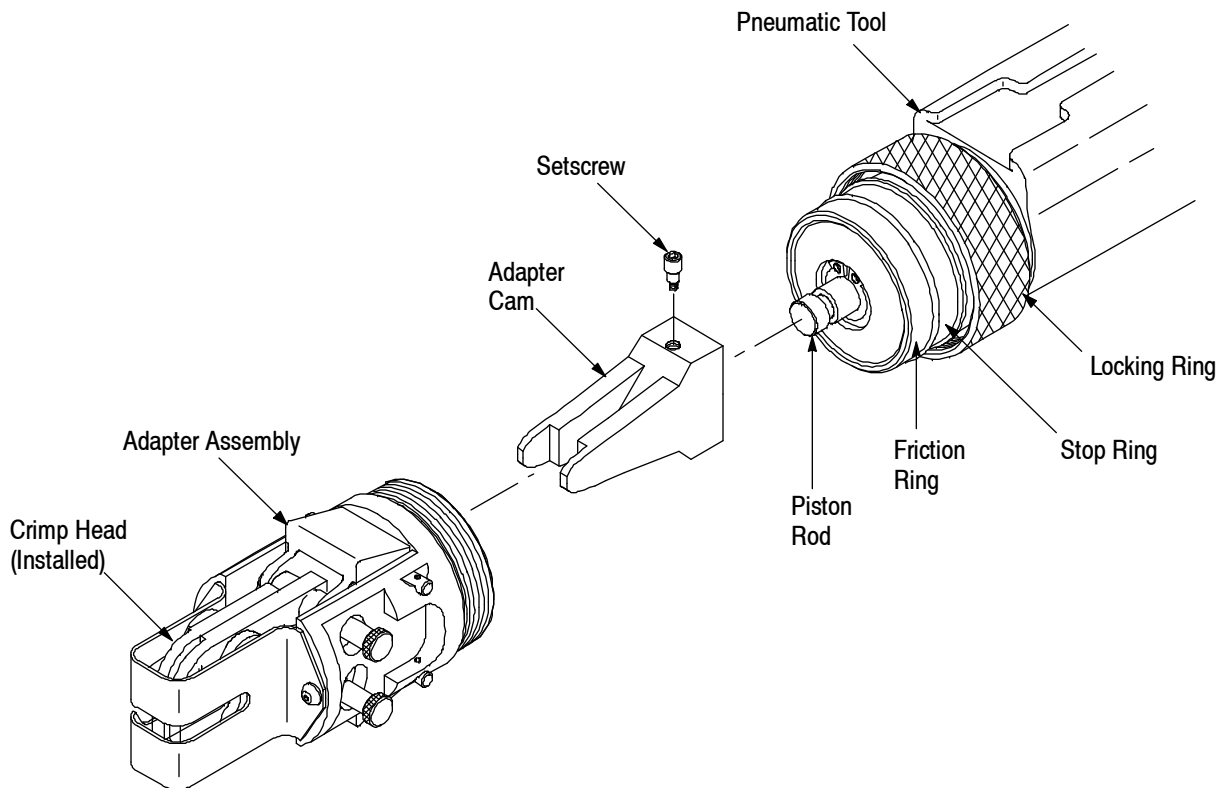

Figure 3

4. Properly align the adapter with the cam and push the adapter onto the pneumatic tool so that it passes over the friction ring of the pneumatic tool.

5. Slide the locking ring toward the adapter until it butts against the stop ring of the pneumatic tool. Then turn the locking ring clockwise to engage threads on the bottom of the adapter. Tighten the locking ring to fully secure the adapter.



When the adapter is properly installed, the locking ring should be butted against the stop ring and threads of the adapter should not be visible. If not properly installed, check that correct combination of cam and adapter was used and that they are aligned properly.

6. Rotate the adapter one full turn in each direction and note that the locking ring rotates with the adapter.



To avoid personal injury, periodically check that the locking ring is tightly securing the adapter.

7. Connect the pneumatic tool to an adequate air supply (between 620 and 690 kPa [90 and 100 psi]). For specific information on air line requirements and air hose installation, refer to 409-5862.

8. Removal is the reverse of installation.

4. MAINTENANCE AND INSPECTION

A maintenance and inspection program should be performed periodically to ensure dependable and uniform terminations.



To avoid personal injury, ALWAYS disconnect the main air supply and electrical supply (if applicable) of the pneumatic tool before performing maintenance or inspection.

4.1. Daily Maintenance

Each operator must be responsible for the following steps of daily maintenance:

1. Remove dust, moisture, and other contaminants with a clean, soft brush, or a lint-free cloth. DO NOT use objects that could damage the adapter.
2. Make sure that all pins, rings, and other components are in place and secure.
3. Make certain all surfaces are protected with a thin coat of any good SAE 20 motor oil. DO NOT oil excessively.
4. When the adapter assembly is not in use, store it in a clean, dry area.

SAE is a trademark of SAE International Corporation.

4.2. Periodic Inspection

Regular inspections should be performed by quality-control personnel. A record of scheduled inspections should remain with the adapter or be supplied to supervisory personnel responsible for the adapter. Though recommendations call for at least one inspection a month, the frequency should be based on amount of use, working conditions, operator training and skill, and your established company policies. These inspections should include the following:

1. Remove all lubrication and accumulated film by immersing the adapter in a suitable commercial degreaser that will not affect paint or plastic.
2. Make certain all components are in place. If replacements are necessary, refer to Section 5, REPLACEMENT AND REPAIR.
3. Check all bearing surfaces for wear. Replace worn parts.

4.3. Lubrication

Lubricate all pins, pivot points, and bearing surfaces with a high quality grease. It is recommended using Dow Corning Molykote paste, which is a commercially

available lubricant. Lubricate according to the following schedule:

- Adapter used in daily production—lubricate daily
- Adapter used daily (occasional)—lubricate weekly
- Adapter used weekly—lubricate monthly

5. REPLACEMENT AND REPAIR

Replacement parts and recommended spare parts are listed in Figure 4. The recommended spare parts should be stocked for immediate replacement. Replacement parts can be ordered from, or when repair is necessary, return adapter (along with a written description of the problem) to:

CUSTOMER SERVICE (38-35)
TYCO ELECTRONICS
PO BOX 3608
HARRISBURG, PA 17105-3608

For customer repair service, call 1-800-526-5136.

6. REVISION SUMMARY

Revisions to this instruction sheet include:

- Added “Original Instructions” to page 1

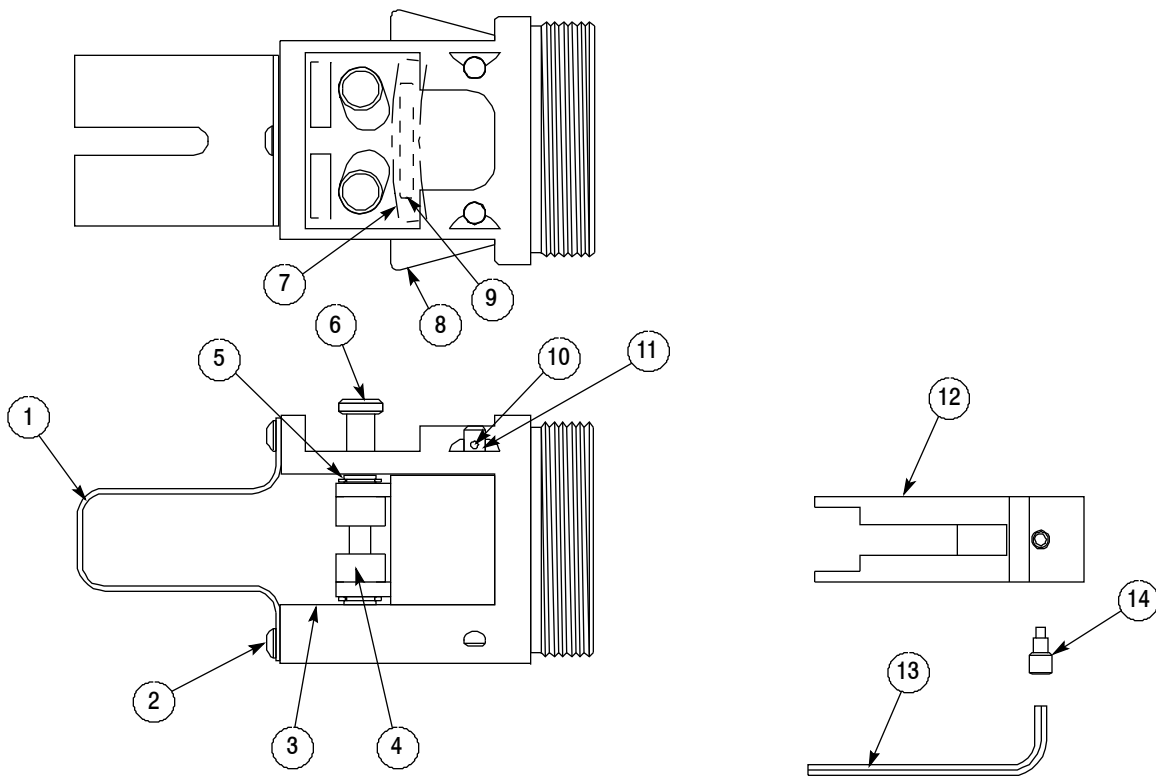

CUSTOMER REPLACEMENT PARTS

ITEM	PART NUMBER	DESCRIPTION	QTY PER ASSEMBLY
1	224984-1	GUARD	1
2	1-21002-6	SCREW, Button Head Cap, No. 6-32 × .25 in.	2
3	1213564-1	ADAPTER	1
4	224938-1 ■	ROLLER	4
5	21985-7	RING, Retaining	4
6	318018-1 ■	PIN, Quick	2
7	5-22280-4	SPRING, Compression	1
8	1213565-1	CLEVIS	2
9	21030-6	PIN, Dowel	1
10	21028-2	PIN, Slotted Spring	2
11	1213566-1	PIN, Hinge	2
12	189763-1	CAM, Small	1
13	21027-6	WRENCH, Hex, .094 in.	1
14	189765-1	SCREW, Set, No. 10-32	1

■ Recommended Spare Parts

Figure 4

Компания «Океан Электроники» предлагает заключение долгосрочных отношений при поставках импортных электронных компонентов на взаимовыгодных условиях!

Наши преимущества:

- Поставка оригинальных импортных электронных компонентов напрямую с производств Америки, Европы и Азии, а так же с крупнейших складов мира;
- Широкая линейка поставок активных и пассивных импортных электронных компонентов (более 30 млн. наименований);
- Поставка сложных, дефицитных, либо снятых с производства позиций;
- Оперативные сроки поставки под заказ (от 5 рабочих дней);
- Экспресс доставка в любую точку России;
- Помощь Конструкторского Отдела и консультации квалифицированных инженеров;
- Техническая поддержка проекта, помощь в подборе аналогов, поставка прототипов;
- Поставка электронных компонентов под контролем ВП;
- Система менеджмента качества сертифицирована по Международному стандарту ISO 9001;
- При необходимости вся продукция военного и аэрокосмического назначения проходит испытания и сертификацию в лаборатории (по согласованию с заказчиком);
- Поставка специализированных компонентов военного и аэрокосмического уровня качества (Xilinx, Altera, Analog Devices, Intersil, Interpoint, Microsemi, Actel, Aeroflex, Peregrine, VPT, Syfer, Eurofarad, Texas Instruments, MS Kennedy, Miteq, Cobham, E2V, MA-COM, Hittite, Mini-Circuits, General Dynamics и др.);

Компания «Океан Электроники» является официальным дистрибьютором и эксклюзивным представителем в России одного из крупнейших производителей разъемов военного и аэрокосмического назначения «JONHON», а так же официальным дистрибьютором и эксклюзивным представителем в России производителя высокотехнологичных и надежных решений для передачи СВЧ сигналов «FORSTAR».



JONHON

«JONHON» (основан в 1970 г.)

Разъемы специального, военного и аэрокосмического назначения:

(Применяются в военной, авиационной, аэрокосмической, морской, железнодорожной, горно- и нефтедобывающей отраслях промышленности)

«FORSTAR» (основан в 1998 г.)

ВЧ соединители, коаксиальные кабели, кабельные сборки и микроволновые компоненты:

(Применяются в телекоммуникациях гражданского и специального назначения, в средствах связи, РЛС, а так же военной, авиационной и аэрокосмической отраслях промышленности).



Телефон: 8 (812) 309-75-97 (многоканальный)

Факс: 8 (812) 320-03-32

Электронная почта: ocean@oceanchips.ru

Web: <http://oceanchips.ru/>

Адрес: 198099, г. Санкт-Петербург, ул. Калинина, д. 2, корп. 4, лит. А