

Enpirion EN5367QI DC-DC Converter w/Integrated Inductor Evaluation Board

Introduction

Thank you for choosing Enpirion, the source for ultra small foot print power converter products! This evaluation board user guide applies to EN5367QI. The EN5367QI is a 6A device. In addition to this document, you will also need the latest device datasheet.

- The EN5367QI features integrated inductor, power MOSFETS, controller, a bulk of the compensation network, and protection circuitry against system faults. This level of integration delivers a substantial reduction in footprint and parts count over competing solutions. The evaluation board is optimized for engineering ease of testing through programming options, clip leads, test points etc.
- The EN5367QI features a customer programmable output voltage by means of a resistor divider. The resistor divider allows the user to set the output voltage to any value within the range 0.75V to $(V_{IN}-V_{DROPOUT})$. The evaluation board, as shipped is populated with a 4 resistor divider option. The upper resistor is fixed and has a phase lead capacitor in parallel. One of 4 lower resistors is selected with the jumper option for different output voltages to change V_{OUT} , retain the upper resistor and capacitor values and change only the lower resistor.
- This device has no over-voltage protection feature. If making modifications to the board, we strongly recommend the customer to ensure the feedback loop is truly closed before powering up the device especially if the load can not withstand the input voltage.
- The input and output capacitors are X5R or X7R multi-layer ceramic chip capacitors. The Soft-start capacitor is a small 47nF X7R MLCC. Pads are available to have multiple input and output capacitors. This allows for evaluation of performance over a wide range of input/output capacitor combinations.
- The jumper labeled LLM/SYNC pin controls the SYNC pin. LLM (light-load mode) function is not available on this part. This pin should be pulled LOW if the SYNC function is not to be used. Do not leave this pin floating or high.
- The jumper labeled VDROOP should be left grounded. This function is not available on this part.
- Clip-on terminals are provided for POK, and ENA, pins.

- Banana jacks are provided for V_{IN} and V_{OUT} power terminals. Several signal and GND clip-on test points are also provided to measure V_{IN} , V_{OUT} , and GND nodes.
- A jumper is provided for controlling the Enable signal. Enable may also be controlled using an external switching source by removing the jumper and applying the enable signal to the ENA clip-on terminal.
- A jumper is also provided to connect a POK pull-up resistor to the input supply. This jumper is especially useful to measure the disable current and eliminates having to subtract the current drawn by the POK resistor.
- Foot print is also provided for a SMA connector to SYNC input. A switching input to this pin allows the device clock to be phase locked to an external signal. This external clock synchronization allows for moving any offending beat frequency to be moved out-of-band. A swept frequency applied to this pin results in spread spectrum operation and reduces the peaks in the noise spectrum of emitted EMI.
- The board comes with input decoupling and reverse polarity protection to guard the device against common setup mishaps.

Quick Start Guide

STEP 1: Set the “ENABLE” jumper to the Disable Position, as shown in Figure 1.

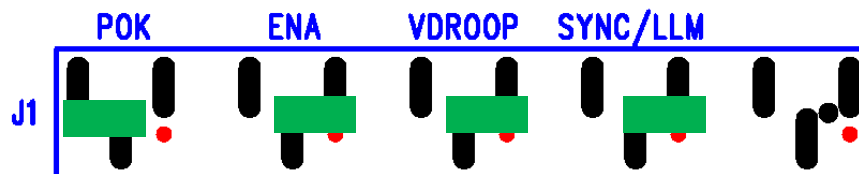

Figure 1: Shows POK, Enable, VDROOP and SYNC/LLM Jumpers. POK PWR jumper as shown connects the pull-up resistor to V_{IN} . Enable jumper shown is in DISABLE position. SYNC/LLM jumper as shown ties this pin Low. VDROOP jumper as shown is low, and should stay grounded.

STEP 2: Connect Power Supply to the input power connectors, V_{IN} (+) and GND (-) as indicated in Figure 1 and set the supply to the desired voltage. The device disable current may be measured in this configuration.

CAUTION: be mindful of the polarity. Even though the evaluation board comes with reverse polarity protection diodes, it may not protect the device under all conditions.

STEP 3: Connect the load to the output connectors VOUT (+) and GND (-), as indicated in Figure 1.

STEP 4: Select the output voltage setting jumper. Figure 2 shows what output voltages are achieved by selecting each jumper position. Populating multiple jumper positions will allow you to select higher output voltages. You can populate up to all four jumper positions for the highest V_{OUT} of approximately 3.73V with the resistors populated on the board.

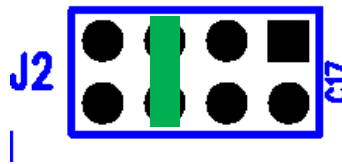

Figure 2: Output Voltage selection jumpers
Jumper shown selects 1.55V output
(Jumper positions from left to right are: 2.25V, 1.55V, 1.2V and 1.0V)

STEP 5: Set the POK PWR and SYNC/LLM jumpers to desired positions (see Figure 1). You should disable POK when measuring low value input currents. The SYNC/LLM jumper should be tied low unless external frequency synchronization is required.

STEP 6: Apply V_{IN} to the board and move the ENA jumper to the enabled position. The EN5367QI is now powered up! Various measurements such as efficiency, line and load regulation, input / output ripple, load transient, drop-out voltage measurements may be conducted at this point. The over current trip level, short circuit protection, under voltage lock out thresholds, temperature coefficient of the output voltage may also be measured in this configuration.

CAUTION: The maximum allowable VIN for this device is 5.5V.

STEP 6A: Power Up/Down Behavior – Remove ENA jumper and connect a pulse generator (output disabled) signal to the clip-on test point below ENA and Ground. Set the pulse amplitude to swing from 0 to 2.5 volts. Set the pulse period to 10msec. and duty cycle to 50%. Hook up oscilloscope probes to ENA, POK and VOUT with clean ground returns. Apply power to evaluation board. Enable pulse generator output. Observe the VOUT voltage ramps as ENA goes high and again as ENA goes low. The device when powered down ramps down the output voltage in a controlled manner before fully shutting down. The output voltage level when POK is asserted /de-asserted as the device is powered up / down may be observed as well as the clean output voltage ramp and POK signals.

STEP 7: External Clock Synchronization / Spread Spectrum Modes: In order to activate this mode, it may be necessary to solder a SMA connector at J7. Alternately

the input clock signal leads may be directly soldered to the through holes of J7 as shown below.

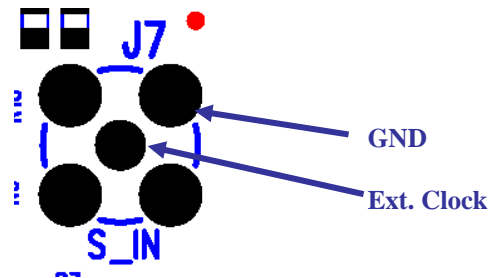

Figure 3: SMA Connector for External Clock Input

Power down the device. Move ENA into disable position. Connect the clock signal as just indicated. The clock signal should be clean and have a frequency in the range of the nominal frequency $\pm 15\%$; amplitude 0 to 2.5 volts with a duty cycle between 20 and 80%. With SYNC signal disabled, power up the device and move ENA jumper to Enabled position. The device is now powered up and outputting the desired voltage. The device is switching at its free running frequency. The switching waveform may be observed between test points SW and GND. Now enabling the SYNC signal will automatically phase lock the internal switching frequency to the externally applied frequency as long as the external clock parameters are within the specified range. To observe phase-lock connect oscilloscope probes to the input clock as well as to the SW test point. Phase lock range can be determined by sweeping the external clock frequency up / down until the device just goes out of lock at the two extremes of its range.

For spread spectrum operation the input clock frequency may be swept between two frequencies that are within the lock range. The sweep (jitter) repetition rate should be limited to 10 kHz. The radiated EMI spectrum may be now measured in various states – free running, phase locked to a fixed frequency and spread spectrum.

Before measuring radiated EMI, place a 10uF/0805, X7R capacitor at the input and output edges of the PCB (C14 and C15), and connect the input power and the load to the board at or near these capacitors. The added capacitor at the input edge is for high-frequency decoupling of the input cables. The one added at the output edge is meant to represent a typical load decoupling capacitor.

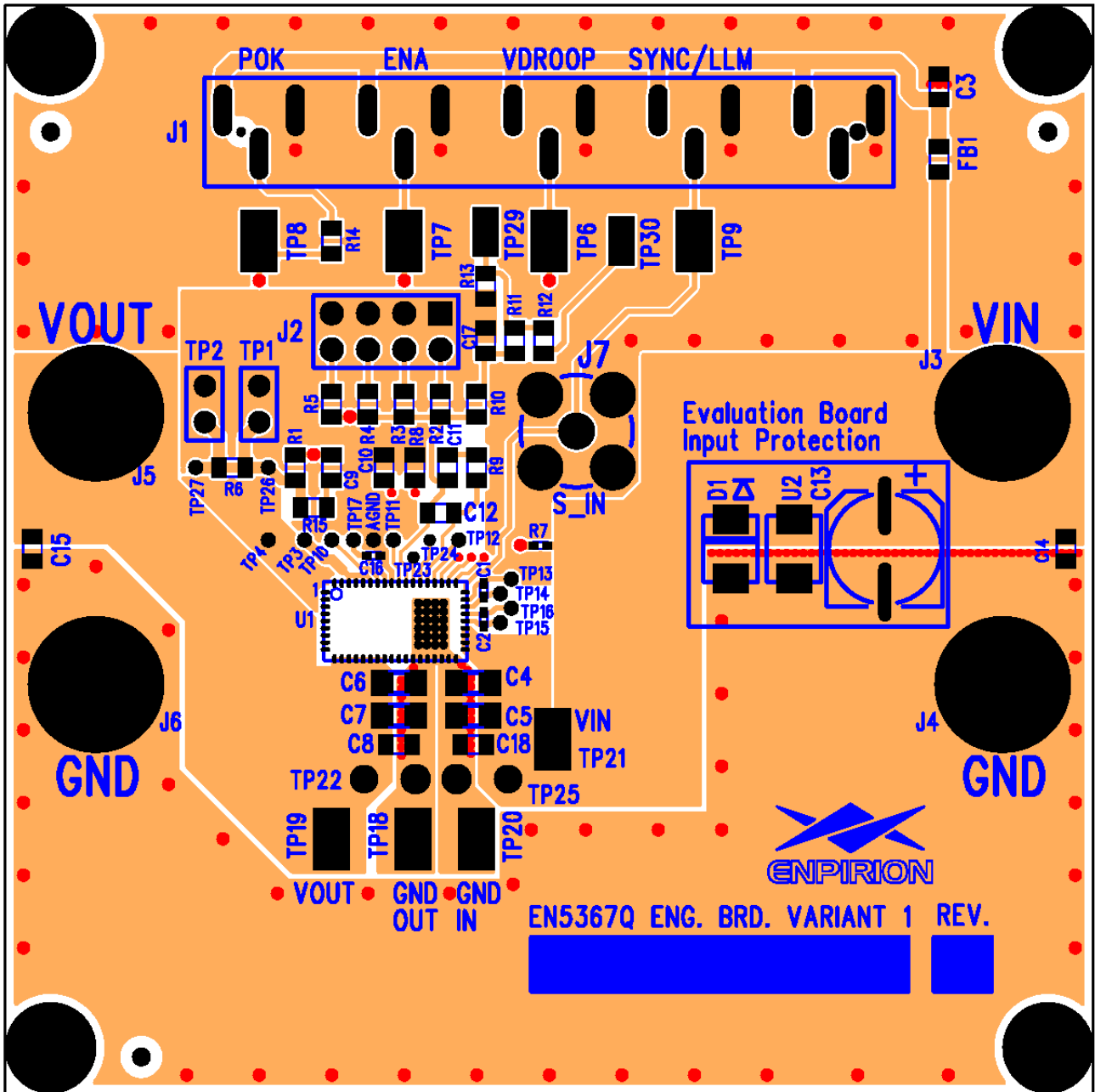

Figure 4: Evaluation Board Layout Top and Assembly Layers

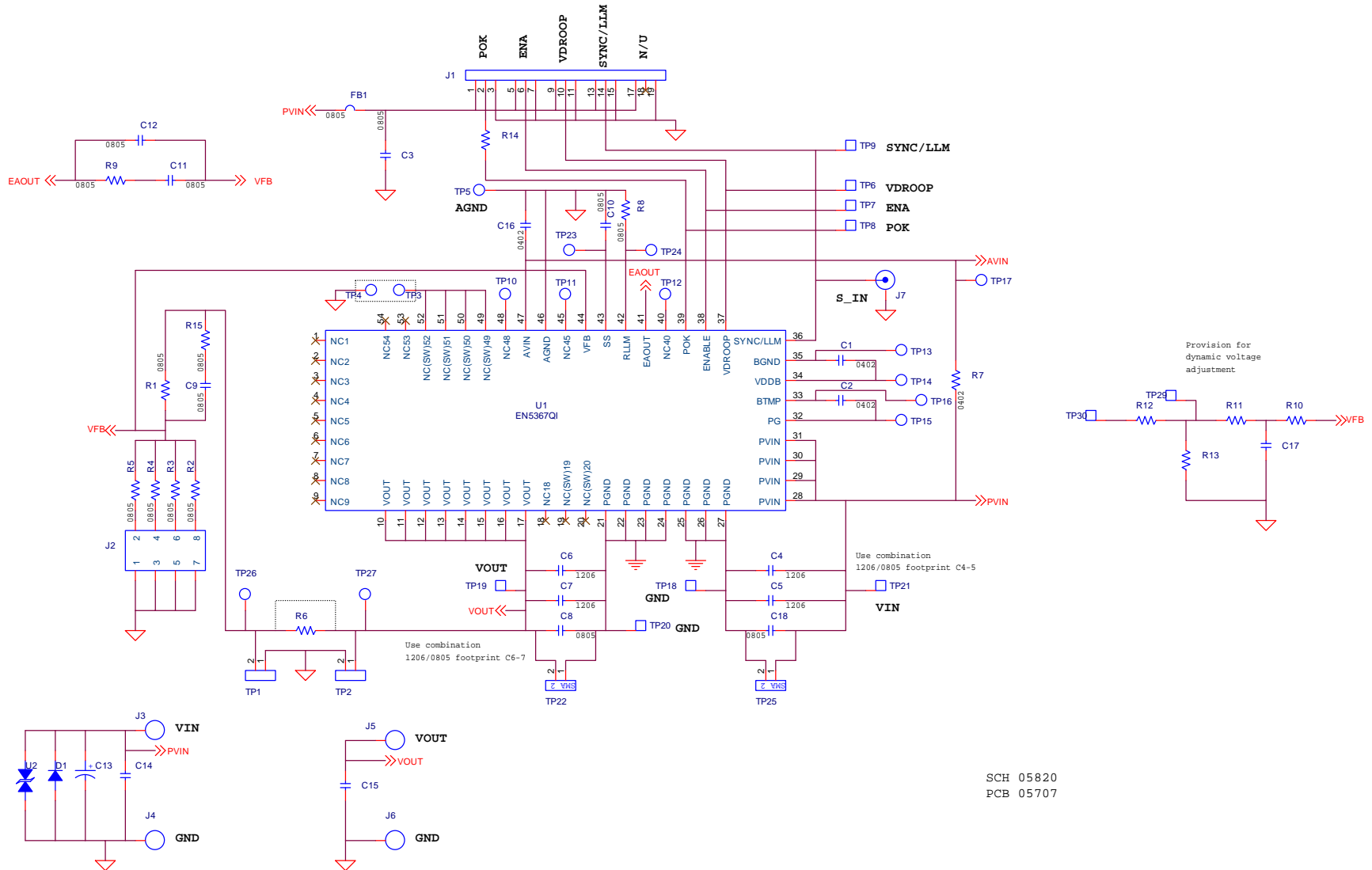
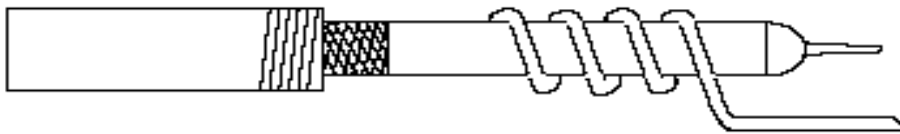

Figure 5: EN5367QI Evaluation Board Schematic

Test Recommendations

To guarantee measurement accuracy, the following precautions should be observed:

1. Make all input and output voltage measurements at the board using the test points provided (TP18 to TP21). This will eliminate voltage drop across the line and load cables that can produce false readings.
2. Measure input and output current with series ammeters or accurate shunt resistors. This is especially important when measuring efficiency.
3. Use a low-loop-inductance scope probe tip shown below to measure switching signals and input / output ripple to avoid noise coupling into the probe ground lead. Input ripple, output ripple, and load transient deviation are best measured near the respective input / output capacitors. For more accurate ripple measurement, please see Enpirion App Note regarding this subject.



4. The board includes a pull-up resistor for the POK signal and ready to monitor the power OK status at clip lead marked POK.
5. A 47nF soft-start capacitor is populated on the board for ~3msec soft-start time.
6. The over-current protection circuit typically limits the maximum load current to approximately 1.5X the rated value.

Bill of Materials

Designator	Qty	Description
C1, C2, C16	3	CAP, 0.1UF 10V X7R 0402 10%
C3, C7	2	CAP, 10UF 0805 X7R 10% 10V CERAMIC
C4, C10	2	CAP, 47000PF 50V X7R 0805
C5, C6	2	CAP, 47UF 10V X5R 1206, CERAMIC
C9	1	CAP, CERAMIC 18PF 5% 50V NP0 0805
C13	1	CAP, 150UF 20% 10V ALUMINUM ELECTROLYTIC
C8, C11, C12, C14, C15, C17, C18, J7, R6, R9-R13	14	NOT USED
D1	1	S2A DIODE
FB1	1	SMT FERRITE BEAD 4000MA 0805 (Wurth Electronik 742792012)
J1	1	CONNECTOR, CUSTOM, VERTICAL HEADER, SMT
J2	1	CONNECTOR HEADER 8POS. 100" STR TIN (Molex 90131-0124)
J3-J6	4	BANANA JACK (Keystone 575-4)



Designator	Qty	Description
R1	1	RESISTOR 150KOHM 1/8W 0.1% 0805 SMD
R2	1	RESISTOR 442KOHM 1/8W 0.1% 0805
R3	1	RESISTOR 0.125W 249KOHM 0.1% 0805
R4	1	RESISTOR 140KOHM 1/8W 0.1% 0805 SMD
R5	1	RESISTOR 75.0KOHM 1/8W 0.1% 0805 SMD
R7	1	RESISTOR 10 OHM 0.1% 0402
R8	1	RESISTOR 200K OHM 0.1% 0805
R14	1	RESISTOR 100K OHM 0805 1%
R15	1	RES 3.57K OHM 1/8W 1% 0805
TP6-TP9, TP18-TP21, TP29, TP30	10	TEST POINT SURFACE MOUNT (Keystone 5016)
U1	1	EN5367QI 6A QFN GOOD TESTED PRODUCT
U2	1	TRANSIENT VOLTAGE SUPPRESSOR, 6.5V, BIDIRECTIONAL (Fairchild SMBJ6V5CA)

Contact Information

Enpirion, Inc.
Perryville III Corporate Park
53 Frontage Road - Suite 210
Hampton, NJ 08827 USA
Phone: +1-908-894-6000
Fax: +1.908-894-6090
www.enpirion.com

Enpirion reserves the right to make changes in circuit design and/or specifications at any time without notice. Information furnished by Enpirion is believed to be accurate and reliable. Enpirion assumes no responsibility for its use or for infringement of patents or other third party rights, which may result from its use. Enpirion products are not authorized for use in nuclear control systems, as critical components in life support systems or equipment used in hazardous environments without the express written authority from Enpirion.

Компания «Океан Электроники» предлагает заключение долгосрочных отношений при поставках импортных электронных компонентов на взаимовыгодных условиях!

Наши преимущества:

- Поставка оригинальных импортных электронных компонентов напрямую с производств Америки, Европы и Азии, а так же с крупнейших складов мира;
- Широкая линейка поставок активных и пассивных импортных электронных компонентов (более 30 млн. наименований);
- Поставка сложных, дефицитных, либо снятых с производства позиций;
- Оперативные сроки поставки под заказ (от 5 рабочих дней);
- Экспресс доставка в любую точку России;
- Помощь Конструкторского Отдела и консультации квалифицированных инженеров;
- Техническая поддержка проекта, помощь в подборе аналогов, поставка прототипов;
- Поставка электронных компонентов под контролем ВП;
- Система менеджмента качества сертифицирована по Международному стандарту ISO 9001;
- При необходимости вся продукция военного и аэрокосмического назначения проходит испытания и сертификацию в лаборатории (по согласованию с заказчиком);
- Поставка специализированных компонентов военного и аэрокосмического уровня качества (Xilinx, Altera, Analog Devices, Intersil, Interpoint, Microsemi, Actel, Aeroflex, Peregrine, VPT, Syfer, Eurofarad, Texas Instruments, MS Kennedy, Miteq, Cobham, E2V, MA-COM, Hittite, Mini-Circuits, General Dynamics и др.);

Компания «Океан Электроники» является официальным дистрибьютором и эксклюзивным представителем в России одного из крупнейших производителей разъемов военного и аэрокосмического назначения «JONHON», а так же официальным дистрибьютором и эксклюзивным представителем в России производителя высокотехнологичных и надежных решений для передачи СВЧ сигналов «FORSTAR».



JONHON

«JONHON» (основан в 1970 г.)

Разъемы специального, военного и аэрокосмического назначения:

(Применяются в военной, авиационной, аэрокосмической, морской, железнодорожной, горно- и нефтедобывающей отраслях промышленности)

«FORSTAR» (основан в 1998 г.)

ВЧ соединители, коаксиальные кабели,
кабельные сборки и микроволновые компоненты:

(Применяются в телекоммуникациях гражданского и специального назначения, в средствах связи, РЛС, а так же военной, авиационной и аэрокосмической отраслях промышленности).



Телефон: 8 (812) 309-75-97 (многоканальный)

Факс: 8 (812) 320-03-32

Электронная почта: ocean@oceanchips.ru

Web: <http://oceanchips.ru/>

Адрес: 198099, г. Санкт-Петербург, ул. Калинина, д. 2, корп. 4, лит. А