

KLEA/KLNA120F

KL A 120 F - -

① ② ③ ④ ⑤ ⑥



Recommended EMI/EMC Filter
NAC-04-472-D



High voltage pulse noise type : NAP series
Low leakage current type : NAM series
*The EMI/EMC Filter is recommended to connect with several devices.

- ① Series name
KLE : Euro Style I/O Terminals
KLN : Barrier Blocks Style I/O Terminals
- ② Single output
- ③ Output wattage
- ④ Universal input
- ⑤ Output voltage
- ⑥ Option
C : with Coating
N2 : Screw mounting

MODEL	KLEA/KLNA120F-24	KLEA/KLNA120F-48
MAX OUTPUT WATTAGE[W]	120	120
DC OUTPUT	24V 5A	48V 2.5A

SPECIFICATIONS

	MODEL	KLEA/KLNA120F-24	KLEA/KLNA120F-48	
INPUT	VOLTAGE[V]	AC85 - 264 1 φ (Output derating is required) *9		
	CURRENT[A]	ACIN 115V	1.2typ	
		ACIN 230V	0.6typ	
	FREQUENCY[Hz]	50 / 60 (47 - 63)		
	EFFICIENCY[%]	ACIN 115V	86.5typ	
		ACIN 230V	88.0typ	
	POWER FACTOR	ACIN 115V	0.98typ	
		ACIN 230V	0.90typ	
INRUSH CURRENT[A]	ACIN 115V	20typ (Io=100%)(at cold start Ta=25°C)		
	*1 ACIN 230V	40typ (Io=100%)(at cold start Ta=25°C)		
LEAKAGE CURRENT[ma]	0.45 / 0.75max (ACIN 100V / 240V 60Hz, Io=100%, According to IEC60950-1 and DEN-AN)			
OUTPUT	VOLTAGE[V]	24	48	
	CURRENT[A]	5	2.5	
	LINE REGULATION[mV] *2	96max (Io=30-100%) *8	192max (Io=30-100%) *8	
	LOAD REGULATION[mV] *2	150max (Io=30-100%) *8	300max (Io=30-100%) *8	
	RIPPLE[mVp-p] *3	0 to +70°C	150max	150max
		-20 - 0°C	240max	240max
		Io=0 - 30%	500max	650max
	RIPPLE NOISE[mVp-p] *3	0 to +70°C	180max	180max
		-20 - 0°C	300max	300max
		Io=0 - 30%	500max	650max
	TEMPERATURE REGULATION[mV]	0 to +70°C	240max	480max
		-20 to +70°C	290max	600max
	DRIFT[mV] *4	96max	192max	
	START-UP TIME[ms]	500typ (ACIN 115V, Io=100%)		
HOLD-UP TIME[ms]	20typ (ACIN 115V, Io=100%)			
OUTPUT VOLTAGE ADJUSTMENT RANGE[V]	21.60 to 26.40	43.20 to 52.80		
OUTPUT VOLTAGE SETTING[V]	24.00 to 24.96	48.00 to 49.92		
PROTECTION CIRCUIT AND OTHERS	OVERCURRENT PROTECTION	Works over 105% of rating and recovers automatically		
	OVERVOLTAGE PROTECTION[V]	27.60 to 33.60	54.00 to 67.20	
	DC_OK LAMP	LED (Green)		
ISOLATION	INPUT-OUTPUT	AC3,000V 1minute, Cutoff current = 10mA, DC500V 50MΩ min (At Room Temperature)		
	INPUT-PE	AC2,000V 1minute, Cutoff current = 10mA, DC500V 50MΩ min (At Room Temperature)		
	OUTPUT-PE	AC500V 1minute, Cutoff current = 100mA, DC500V 50MΩ min (At Room Temperature)		
ENVIRONMENT	OPERATING TEMP., HUMID. AND ALTITUDE	-20 to +70°C (Required to Derating), 20 - 90%RH (Non condensing)		
	STORAGE TEMP., HUMID. AND ALTITUDE	-30 to +85°C, 20 - 90%RH (Non condensing)		
	VIBRATION *7	10 - 55Hz, 19.6m/s ² (2G), 3minutes period, 60 minutes along Z axis (Non operating, mounted on DIN Rail)		
	IMPACT	196.1m/s ² (20G), 11ms, once each X, Y and Z axis (Packing state)		
SAFETY AND NOISE REGULATIONS	AGENCY APPROVALS	UL60950-1, C-UL (CSA60950-1), EN60950-1, UL508, Complies with DEN-AN		
	CONDUCTED NOISE	Complies with FCC-B, VCCI-B, CISPR22-B, EN55011-B, EN55022-B		
	HARMONIC ATTENUATOR	Complies with IEC61000-3-2 (Class A) *5		
OTHERS	CASE SIZE *6	38 × 124 × 117mm (W × H × D) [1.5 × 4.88 × 4.61 inches]		
	WEIGHT	580g max		
	COOLING METHOD	Convection / Forced air		

*1 The value is primary surge. The current of input surge to a built-in EMI/EMC Filter (0.2ms or less) is excluded.
*2 Please contact us about dynamic load and input response.
*3 This is the value that measured on measuring board with capacitor of 22 μF and 0.1 μF at 150mm from output terminal.
Measured by 20MHz oscilloscope or Ripple-Noise meter (Equivalent to KEISOKU-GIKEN: RM103).
Please refer to the instruction manual 2.5.

*4 Drift is the change in DC output for an eight hour period after a half-hour warm-up at 25°C, with the input voltage held constant at the rated input/output.
*5 Please contact us about another class.
*6 Case size contains neither the umbro.
*7 Only as standard mounting orientation (A). Refer to the instruction manual 4.1. If install other than standard mounting orientation (A), please fix the power supply for withstand the vibration and impact.

*8 Burst operation at 30% load or less.
*9 Please contact us about DC input voltage.
* To meet the specifications. Do not operate over-loaded condition.
* A sound may occur from power supply at light or peak loading.

Block diagram

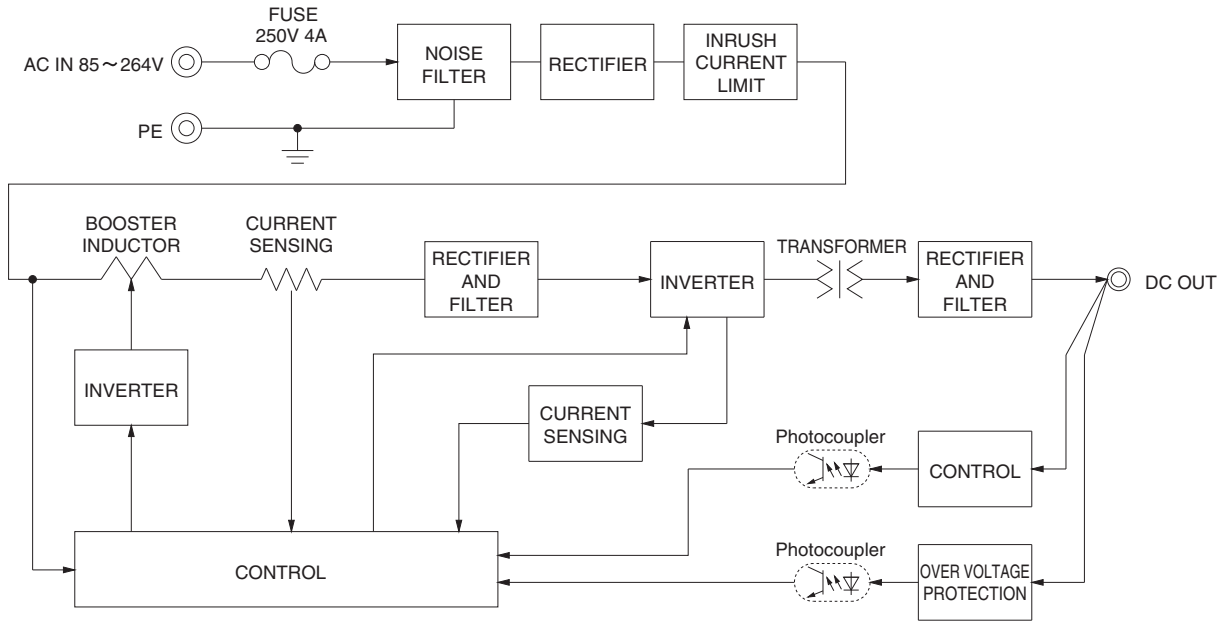

External view

<KLEA120F(Euro Style I/O Terminals)>

<KLNA120F(Barrier Blocks Style I/O Terminals)>

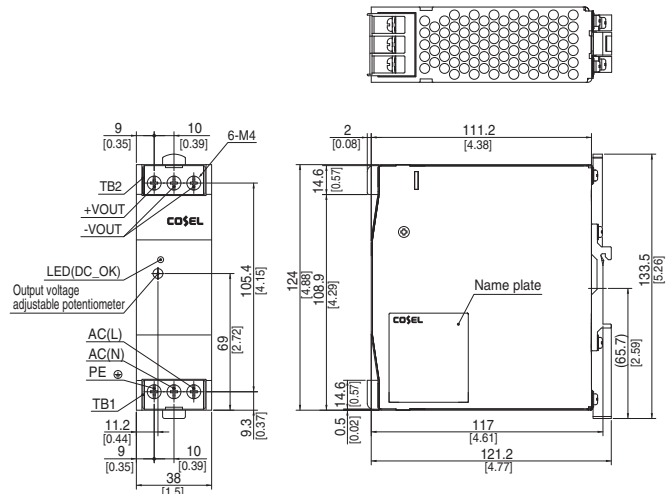
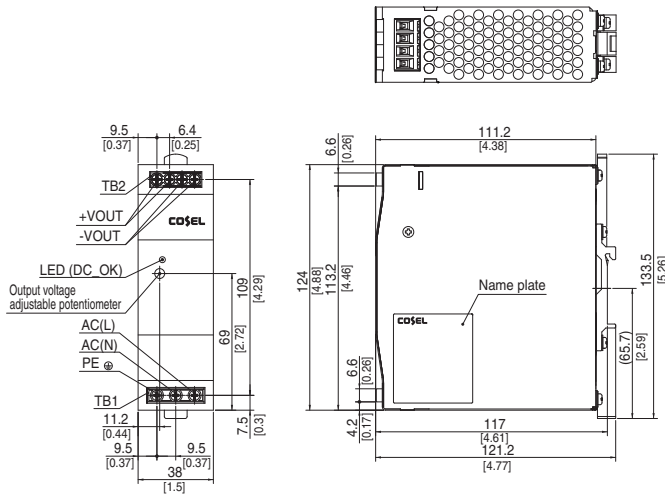

- ※ Tolerance : ±1.5 [±0.06]
- ※ Weight : 580g max
- ※ PCB Material/thickness : FR-4 / 1.6mm [0.06]
- ※ Chassis material : Aluminum
- ※ Case material : Stainless steel
- ※ Din rail attachment material : Aluminum, Nylon
- ※ Dimensions in mm, [] = inches
- ※ Screw tightening torque : 1N · m max

- ※ Tolerance : ±1.5 [±0.06]
- ※ Weight : 580g max
- ※ PCB Material/thickness : FR-4 / 1.6mm [0.06]
- ※ Chassis material : Aluminum
- ※ Case material : Stainless steel
- ※ Din rail attachment material : Aluminum, Nylon
- ※ Dimensions in mm, [] = inches
- ※ Screw tightening torque : 1.6N · m max

KLEA/KLNA240F

KL A 240 F - -

① ② ③ ④ ⑤ ⑥



Recommended EMI/EMC Filter
NAC-06-472-D



High voltage pulse noise type : NAP series
Low leakage current type : NAM series
*The EMI/EMC Filter is recommended to connect with several devices.

- ① Series name
KLE : Euro Style I/O Terminals
KLN : Barrier Blocks Style I/O Terminals
- ② Single output
- ③ Output wattage
- ④ Universal input
- ⑤ Output voltage
- ⑥ Option
C : with Coating
N2 : Screw mounting

MODEL	KLEA/KLNA240F-24	KLEA/KLNA240F-48
MAX OUTPUT WATTAGE[W]	240	240
DC OUTPUT	24V 10A	48V 5A

SPECIFICATIONS

	MODEL	KLEA/KLNA240F-24	KLEA/KLNA240F-48	
INPUT	VOLTAGE[V]	AC85 - 264 1 φ (Output derating is required) *8		
	CURRENT[A]	ACIN 115V	2.4typ	
		ACIN 230V	1.3typ	
	FREQUENCY[Hz]	50 / 60 (47 - 63)		
	EFFICIENCY[%]	ACIN 115V	88typ	
		ACIN 230V	90typ	
	POWER FACTOR	ACIN 115V	0.98typ	
		ACIN 230V	0.90typ	
INRUSH CURRENT[A]	ACIN 115V	20typ (I _o =100%)(at cold start Ta=25°C)		
	*1 ACIN 230V	40typ (I _o =100%)(at cold start Ta=25°C)		
LEAKAGE CURRENT[ma]	0.45 / 0.75max (ACIN 100V / 240V 60Hz, I _o =100%, According to IEC60950-1 and DEN-AN)			
OUTPUT	VOLTAGE[V]	24	48	
	CURRENT[A]	10	5	
	LINE REGULATION[mV] *2	96max		
	LOAD REGULATION[mV] *2	150max		
	RIPPLE[mVp-p] *3	0 to +70°C	150max	150max
		-20 - 0°C	240max	240max
	RIPPLE NOISE[mVp-p] *3	0 to +70°C	180max	180max
		-20 - 0°C	300max	300max
	TEMPERATURE REGULATION[mV]	0 to +70°C	240max	480max
		-20 to +70°C	290max	600max
	DRIFT[mV] *4	96max		
	START-UP TIME[ms]	500typ (ACIN 115V, I _o =100%)		
	HOLD-UP TIME[ms]	20typ (ACIN 115V, I _o =100%)		
OUTPUT VOLTAGE ADJUSTMENT RANGE[V]	21.60 to 26.40	43.20 to 52.80		
OUTPUT VOLTAGE SETTING[V]	24.00 to 24.96	48.00 to 49.92		
PROTECTION CIRCUIT AND OTHERS	OVERCURRENT PROTECTION	Works over 105% of rating and recovers automatically		
	OVERVOLTAGE PROTECTION[V]	27.60 to 33.60	54.00 to 67.20	
	DC_OK LAMP	LED (Green)		
ISOLATION	INPUT-OUTPUT	AC3,000V 1minute, Cutoff current = 10mA, DC500V 50MΩ min (At Room Temperature)		
	INPUT-PE	AC2,000V 1minute, Cutoff current = 10mA, DC500V 50MΩ min (At Room Temperature)		
	OUTPUT-PE	AC500V 1minute, Cutoff current = 100mA, DC500V 50MΩ min (At Room Temperature)		
ENVIRONMENT	OPERATING TEMP.,HUMID.AND ALTITUDE	-20 to +70°C (Required to Derating), 20 - 90%RH (Non condensing)		
	STORAGE TEMP.,HUMID.AND ALTITUDE	-30 to +85°C, 20 - 90%RH (Non condensing)		
	VIBRATION *7	10 - 55Hz, 19.6m/s ² (2G), 3minutes period, 60 minutes along Z axis (Non operating, mounted on DIN Rail)		
	IMPACT	196.1m/s ² (20G), 11ms, once each X, Y and Z axis (Packing state)		
SAFETY AND NOISE REGULATIONS	AGENCY APPROVALS	UL60950-1, C-UL (CSA60950-1), EN60950-1, UL508, Complies with DEN-AN		
	CONDUCTED NOISE	Complies with FCC-B, VCCI-B, CISPR22-B, EN55011-B, EN55022-B		
	HARMONIC ATTENUATOR	Complies with IEC61000-3-2 (Class A) *5		
OTHERS	CASE SIZE *6	50 × 124 × 117mm (W × H × D) [1.97 × 4.88 × 4.61 inches]		
	WEIGHT	750g max		
	COOLING METHOD	Convection / Forced air		

*1 The value is primary surge. The current of input surge to a built-in EMI/EMC Filter(0.2ms or less)is excluded.
*2 Please contact us about dynamic load and input response.
*3 This is the value that measured on measuring board with capacitor of 22 μF and 0.1 μF at 150mm from output terminal.
Measured by 20MHz oscilloscope or Ripple-Noise meter (Equivalent to KEISOKU-GIKEN: RM103).
Please refer to the instruction manual 2.5.

*4 Drift is the change in DC output for a eight hour period after a half-hour warm-up at 25°C, with the input voltage held constant at the rated input/output.
*5 Please contact us about another class.
*6 Case size contains neither the umbo.
*7 Only as standard mounting orientation (A). Refer to the instruction manual 4.1. If install other than standard mounting orientation (A), please fix the power supply for withstand the vibration and impact.

*8 Please contact us about DC input voltage.
* To meet the specifications. Do not operate over-loaded condition.
* A sound may occur from power supply at light or peak loading.

Block diagram

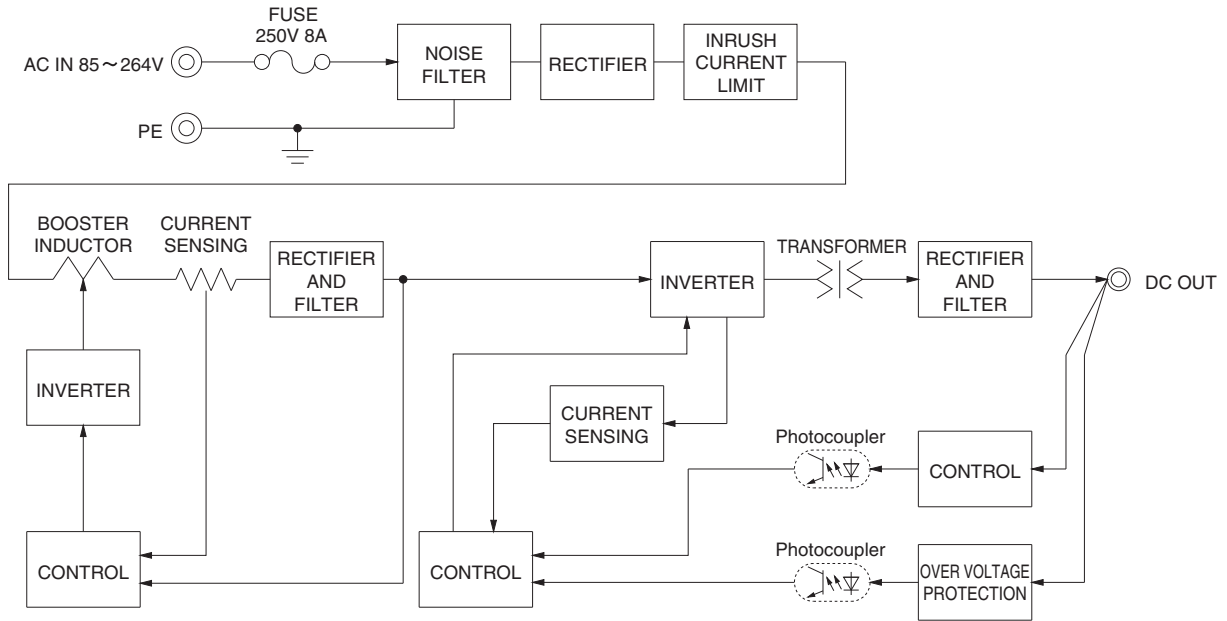

External view

<KLEA240F(Euro Style I/O Terminals)>

<KLNA240F(Barrier Blocks Style I/O Terminals)>

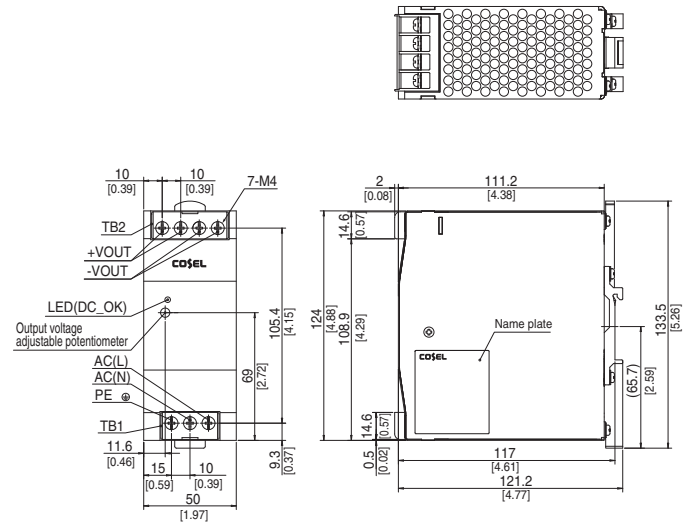
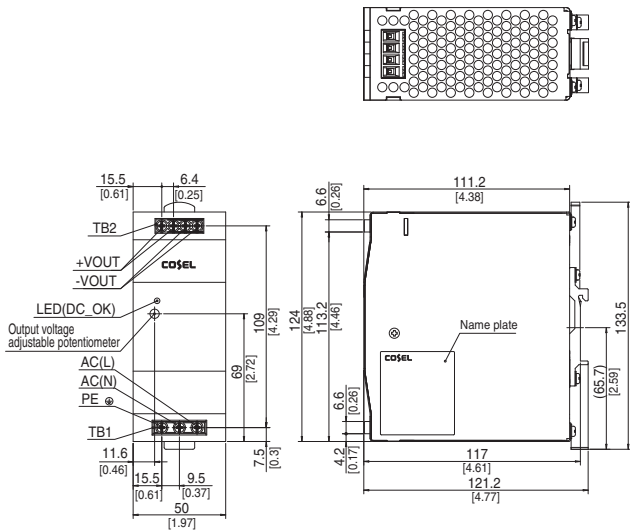

- ※ Tolerance : ±1.5 [±0.06]
- ※ Weight : 750g max
- ※ PCB Material/thickness : FR-4 / 1.6mm [0.06]
- ※ Chassis material : Aluminum
- ※ Case material : Stainless steel
- ※ Din rail attachment material : Aluminum, Nylon
- ※ Dimensions in mm, [] = inches
- ※ Screw tightening torque : 1N · m max

- ※ Tolerance : ±1.5 [±0.06]
- ※ Weight : 750g max
- ※ PCB Material/thickness : FR-4 / 1.6mm [0.06]
- ※ Chassis material : Aluminum
- ※ Case material : Stainless steel
- ※ Din rail attachment material : Aluminum, Nylon
- ※ Dimensions in mm, [] = inches
- ※ Screw tightening torque : 1.6N · m max

Mouser Electronics

Authorized Distributor

Click to View Pricing, Inventory, Delivery & Lifecycle Information:

Cosel:

[KLEA240F-48](#) [KLEA120F-48](#) [KLEA240F-24](#) [KLEA120F-24](#)

Компания «Океан Электроники» предлагает заключение долгосрочных отношений при поставках импортных электронных компонентов на взаимовыгодных условиях!

Наши преимущества:

- Поставка оригинальных импортных электронных компонентов напрямую с производств Америки, Европы и Азии, а так же с крупнейших складов мира;
- Широкая линейка поставок активных и пассивных импортных электронных компонентов (более 30 млн. наименований);
- Поставка сложных, дефицитных, либо снятых с производства позиций;
- Оперативные сроки поставки под заказ (от 5 рабочих дней);
- Экспресс доставка в любую точку России;
- Помощь Конструкторского Отдела и консультации квалифицированных инженеров;
- Техническая поддержка проекта, помощь в подборе аналогов, поставка прототипов;
- Поставка электронных компонентов под контролем ВП;
- Система менеджмента качества сертифицирована по Международному стандарту ISO 9001;
- При необходимости вся продукция военного и аэрокосмического назначения проходит испытания и сертификацию в лаборатории (по согласованию с заказчиком);
- Поставка специализированных компонентов военного и аэрокосмического уровня качества (Xilinx, Altera, Analog Devices, Intersil, Interpoint, Microsemi, Actel, Aeroflex, Peregrine, VPT, Syfer, Eurofarad, Texas Instruments, MS Kennedy, Miteq, Cobham, E2V, MA-COM, Hittite, Mini-Circuits, General Dynamics и др.);

Компания «Океан Электроники» является официальным дистрибьютором и эксклюзивным представителем в России одного из крупнейших производителей разъемов военного и аэрокосмического назначения «JONHON», а так же официальным дистрибьютором и эксклюзивным представителем в России производителя высокотехнологичных и надежных решений для передачи СВЧ сигналов «FORSTAR».



JONHON

«JONHON» (основан в 1970 г.)

Разъемы специального, военного и аэрокосмического назначения:

(Применяются в военной, авиационной, аэрокосмической, морской, железнодорожной, горно- и нефтедобывающей отраслях промышленности)

«FORSTAR» (основан в 1998 г.)

ВЧ соединители, коаксиальные кабели,
кабельные сборки и микроволновые компоненты:

(Применяются в телекоммуникациях гражданского и специального назначения, в средствах связи, РЛС, а так же военной, авиационной и аэрокосмической отраслях промышленности).



Телефон: 8 (812) 309-75-97 (многоканальный)

Факс: 8 (812) 320-03-32

Электронная почта: ocean@oceanchips.ru

Web: <http://oceanchips.ru/>

Адрес: 198099, г. Санкт-Петербург, ул. Калинина, д. 2, корп. 4, лит. А