



Enpirion[®] Power Evaluation Board

ER3125QI 2.5A Regulator with Integrate High-Side MOSFET for Synchronous Buck Evaluation Board User Guide

Description

This is the ER3125QI Evaluation Board User Guide. The ER3125QI features a wide input range of 3V to 36V for a synchronous buck with a high-side MOSFET and low-side driver integrated, flexible selection of operation modes of forced PWM mode and LLM mode, Programmable frequency, and protection

circuitry against system faults. This level of integration delivers a substantial reduction in footprint and part count over competing solutions. The evaluation board is optimized for engineering ease of testing through programming options, clip leads, test points and supporting external components.

Evaluation Board Over View

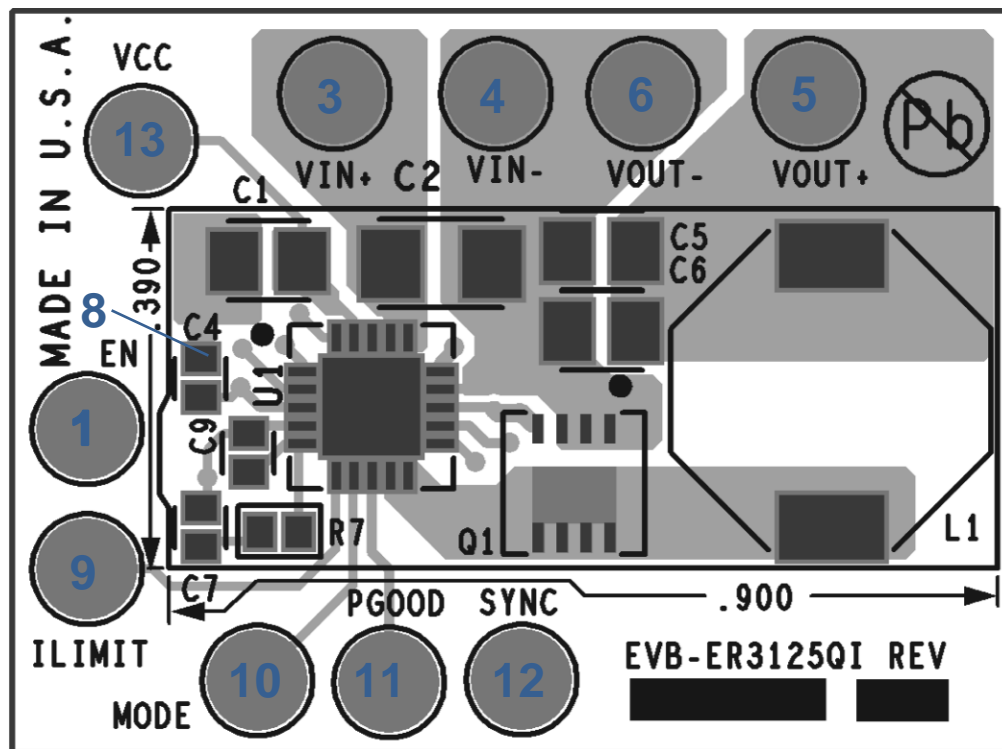

(a) ER3125QI EVB Top Side

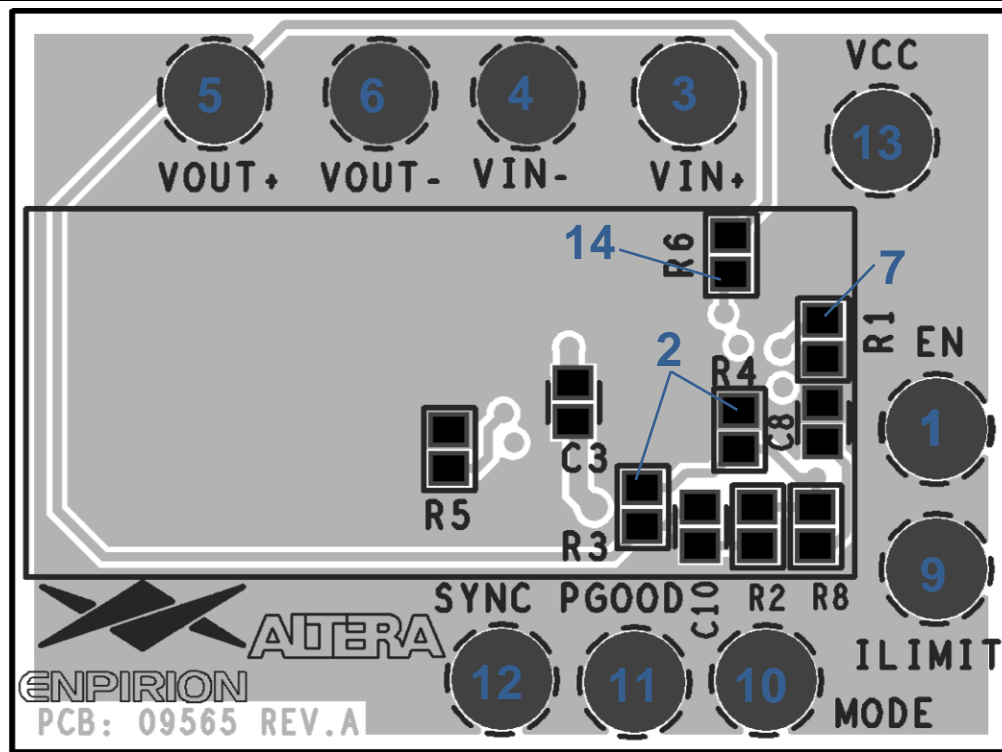

(b) ER3125QI EVB Bottom Side

Figure 1. ER3125QI Evaluation Board Illustration (Follow instructions on page 2)

Instructions

The numbers in the instructions below correspond to the numbers in Figure 1. By following the number sequence below, the device can be turned on by step 6.

- 1) **ENABLE** – Left floating or connect an external clock for ON/OFF operation (0V to 5.5V). The device is disabled when this pin is pulled LOW.
- 2) **Output Voltage Setting** – The output voltage programming resistor R4, depends on the value chosen for the feedback resistor R3 and the desired output voltage VOUT. Equation 1 describes the relationship between VOUT and the resistor values.

$$R_4 = R_3 * 0.6V / (V_{out} - 0.6V) \quad (1)$$
 The feedback resistor R3 is chosen as 232kΩ. When changing the output voltage it may also be necessary to change certain other circuit elements for stability. See datasheet page 23 for more details.
- 3) **VIN+ (PVIN)** – Connect the positive terminal of a 3.0V to 36.0V power supply to VIN+.

Do not turn the power supply on until everything is connected correctly.

- 4) **VIN- (Input Ground)** – Connect the input power supply ground to VIN-.
- 5) **VOUT+ (VOUT)** – Connect the load to VOUT+.
- 6) **VOUT- (Output Ground)** – Connect the load ground to VOUT-. If the instructions were followed up to this point, the power supply may be turned on.
- 7) **FSW (R1)** – The ER3125QI Evaluation Board operates at the default switching frequency mode (500kHz). The frequency can be programmed to any frequency between 200kHz and 2.2MHz with a resistor R_{FSW} (R1) from FSW pin to GND.

$$R_1 = (145000 - 16 * F_{SW}(kHz)) / F_{SW}(kHz) \quad (2)$$

- 8) **Soft Start Capacitor (C_{SS})** – The soft start capacitor is by defaulted 15nF. See

Datasheet for details. The soft-start time can be calculated by Equation 3:

$$C_{ss}(\mu F) = 6.5 * Time (s) \quad (3)$$

- 9) **RCLX (ILIMIT)** – The ER3125QI EVB operates at default current limiting (3.6A).
- 10) **LLM (MODE)** – The ER3125QI EVB operates at PFM Mode (Pulse Frequency Modulation) operation in light load. In LLM mode, the switching frequency is dramatically reduced to minimize the switching loss. The ER3125QI enters LLM mode when the MOSFET peak current is lower than the PWM/LLM boundary current threshold. The default threshold is 700mA when there is no programming resistor at the LLM pin.
- 11) **POK (PGOOD)** – POK is an open drain output and pull-up pin with a resistor to AVINO for proper function. POK will be pulled low under the events when the output is out of regulation (OV or UV) or EN pin is pulled low. POK rising has a fixed 128 cycles delay.
- 12) **SYNC** – This pin can be used to synchronize two or more ER3125QI controllers. Multiple ER3125QIs can be synchronized with their SYNC pins connected together. 180° phase shift is automatically generated between the master and slave ICs. The internal oscillator can also lock to an external frequency source applied on this pin with square pulse waveform (with frequency 10% higher than the IC's local frequency, and pulse width higher than 150ns). Range: 0V to 5.5V.
- 13) **AVINO (VCC)** – This pin is the output of the internal linear regulator that supplies the bias for the IC including the driver.
- 14) **AVIN** – This pin is the input of the auxiliary internal linear regulator, which can be supplied by the regulator output after power-up. With such configuration, the power dissipation inside of the IC is reduced. The input range for this LDO is 3V to 20V.

Evaluation Board Schematic

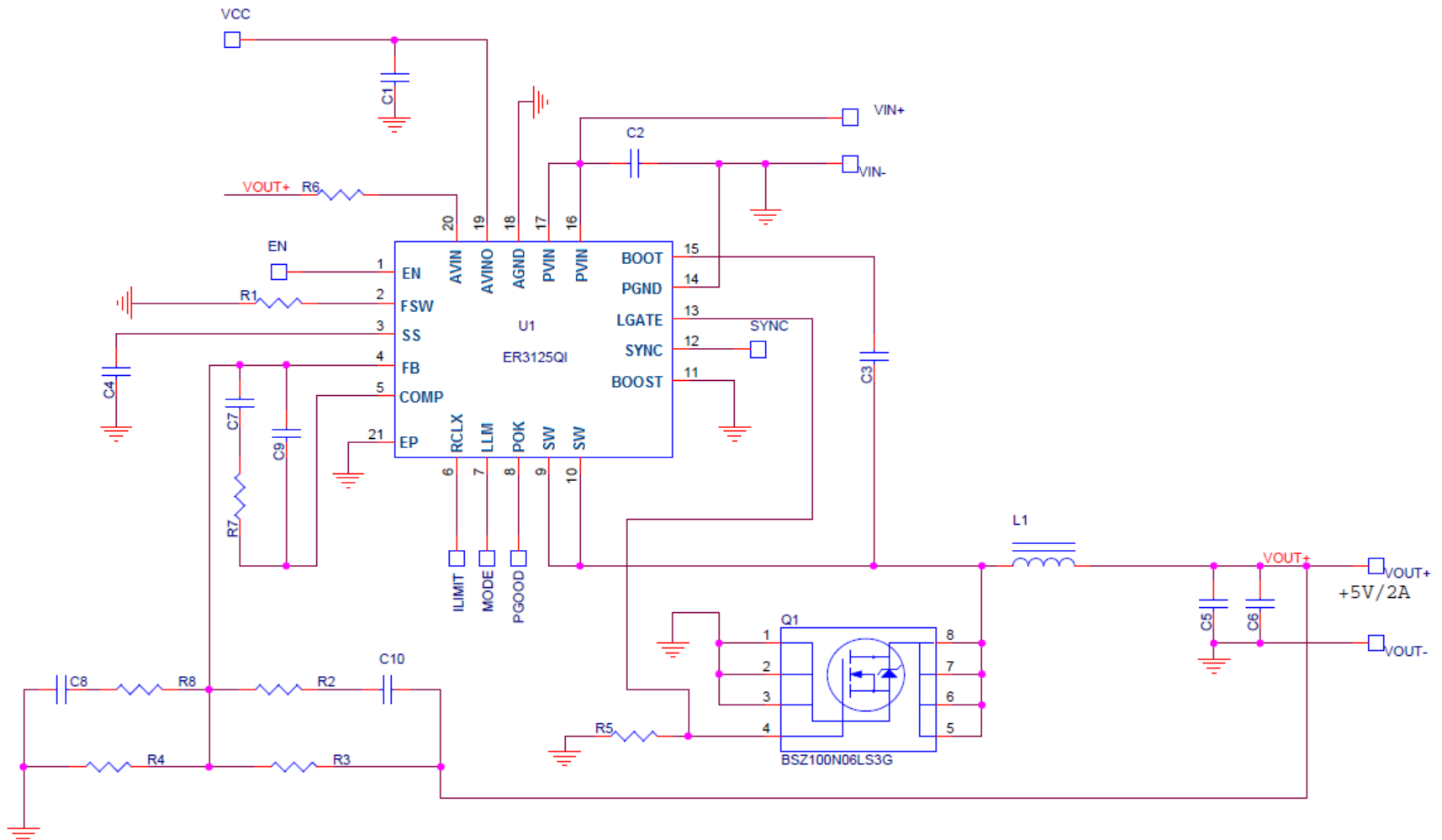

Bill of Materials

Designator	Qty	Description
C1	1	4.7UF 10V X7R 10% 0805 CERAMIC CAPACITOR
C2	1	CAP CER 10UF 50V 10% X5R 1206
C3	1	CAP CER 1UF 6.3V 20% X5R 0402
C4	1	CAP CER 0.015UF 15000pf 15nf 16V 10% X7R 0402
C5, C6	2	CAP CER 10UF 6.3V 10% X5R 0805
C7	1	CAP CER 100PF 50V 5% NPO 0402
C9	1	CAP CER 10PF 50V 5% NP0 0402
C10	1	CAP CER 150PF 25V 5% NP0 0402
L1	1	INDUCTOR SHIELDED 10UH 4.0A 31.4mOhms SMD
Q1	1	MOSFET N-CH 60V 20A TSDSON-8
R2	1	RES 3.92K OHM 1/16W 1% 0402
R3	1	RES 232K OHM 1/10W 1% 0402 SMD
R4	1	RES 44.2K OHM 1/16W 1% 0402
R5	1	RES 4.7K OHM 1/16W 1% 0402
R6	1	RESISTOR ZERO OHM 1/10W 5% 0402 SMD
R7	1	RES 2K OHM 1/16W 1% 0402
U1	1	ER3125QI 2.5A Regulator with Integrated High-Side MOSFET for Synchronous Buck or Boost Buck Converter

Test Recommendations

To guarantee measurement accuracy, the following precautions should be observed:

1. Make all input and output voltage measurements at the board using the test points provided. This will eliminate voltage drop across the line and load cables that can produce false readings.
2. Measure input and output current with series ammeters or accurate shunt resistors. This is especially important when measuring efficiency.
3. The board includes a pull-up resistor for the POK signal and ready to monitor the power OK status at clip lead marked POK.

Contact Information

Altera Corporation
 101 Innovation Drive
 San Jose, CA 95134
 Phone: 408-544-7000
www.altera.com

© 2013 Altera Corporation—Confidential. All rights reserved. ALTERA, ARRIA, CYCLONE, ENPIRION, HARDCOPY, MAX, MEGACORE, NIOS, QUARTUS and STRATIX words and logos are trademarks of Altera Corporation and registered in the U.S. Patent and Trademark Office and in other countries. All other words and logos identified as trademarks or service marks are the property of their respective holders as described at www.altera.com/common/legal.html. Altera warrants performance of its semiconductor products to current specifications in accordance with Altera's standard warranty, but reserves the right to make changes to any products and services at any time without notice. Altera assumes no responsibility or liability arising out of the application or use of any information, product, or service described herein except as expressly agreed to in writing by Altera. Altera customers are advised to obtain the latest version of device specifications before relying on any published information and before placing orders for products or services.

Компания «Океан Электроники» предлагает заключение долгосрочных отношений при поставках импортных электронных компонентов на взаимовыгодных условиях!

Наши преимущества:

- Поставка оригинальных импортных электронных компонентов напрямую с производств Америки, Европы и Азии, а так же с крупнейших складов мира;
- Широкая линейка поставок активных и пассивных импортных электронных компонентов (более 30 млн. наименований);
- Поставка сложных, дефицитных, либо снятых с производства позиций;
- Оперативные сроки поставки под заказ (от 5 рабочих дней);
- Экспресс доставка в любую точку России;
- Помощь Конструкторского Отдела и консультации квалифицированных инженеров;
- Техническая поддержка проекта, помощь в подборе аналогов, поставка прототипов;
- Поставка электронных компонентов под контролем ВП;
- Система менеджмента качества сертифицирована по Международному стандарту ISO 9001;
- При необходимости вся продукция военного и аэрокосмического назначения проходит испытания и сертификацию в лаборатории (по согласованию с заказчиком);
- Поставка специализированных компонентов военного и аэрокосмического уровня качества (Xilinx, Altera, Analog Devices, Intersil, Interpoint, Microsemi, Actel, Aeroflex, Peregrine, VPT, Syfer, Eurofarad, Texas Instruments, MS Kennedy, Miteq, Cobham, E2V, MA-COM, Hittite, Mini-Circuits, General Dynamics и др.);

Компания «Океан Электроники» является официальным дистрибьютором и эксклюзивным представителем в России одного из крупнейших производителей разъемов военного и аэрокосмического назначения «**JONHON**», а так же официальным дистрибьютором и эксклюзивным представителем в России производителя высокотехнологичных и надежных решений для передачи СВЧ сигналов «**FORSTAR**».



JONHON

«**JONHON**» (основан в 1970 г.)

Разъемы специального, военного и аэрокосмического назначения:

(Применяются в военной, авиационной, аэрокосмической, морской, железнодорожной, горно- и нефтедобывающей отраслях промышленности)

«**FORSTAR**» (основан в 1998 г.)

ВЧ соединители, коаксиальные кабели,
кабельные сборки и микроволновые компоненты:

(Применяются в телекоммуникациях гражданского и специального назначения, в средствах связи, РЛС, а так же военной, авиационной и аэрокосмической отраслях промышленности).



Телефон: 8 (812) 309-75-97 (многоканальный)

Факс: 8 (812) 320-03-32

Электронная почта: ocean@oceanchips.ru

Web: <http://oceanchips.ru/>

Адрес: 198099, г. Санкт-Петербург, ул. Калинина, д. 2, корп. 4, лит. А