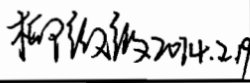
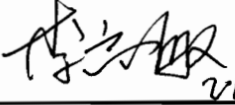
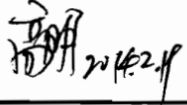
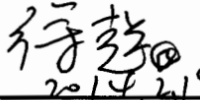

Product Specification

Product Name: VGM128064C1A04

Product Code: M00873

Customer
Approved by Customer
Approved Date:

Designed By	Checked By	Approved By	
		R&D	QA
 2014.2.19	 2014.2.19	 2014.2.19	 2014.2.19

CONTENT

REVISION RECORD	3
1 OVERVIEW	4
2 FEATURES	4
3 MECHANICAL DATA	4
4 MECHANICAL DRAWING	5
5 MODULE INTERFACE	6
6 FUNCTION BLOCK DIAGRAM	7
6.1 FUNCTION BLOCK DIAGRAM.....	7
6.2 PANEL LAYOUT DIAGRAM	7
7 ABSOLUTE MAXIMUM RATINGS	8
8 ELECTRICAL CHARACTERISTICS	8
8.1 DC ELECTRICAL CHARACTERISTICS	8
8.2 ELECTRO-OPTICAL CHARACTERISTICS	9
8.3 AC ELECTRICAL CHARACTERISTICS	10
9 FUNCTIONAL SPECIFICATION AND APPLICATION CIRCUIT	12
9.1 POWER ON AND POWER OFF SEQUENCE.....	12
9.2 APPLICATION CIRCUIT.....	15
9.3 EXTERNAL DC-DC APPLICATION CIRCUIT	16
9.4 DISPLAY CONTROL INSTRUCTION.....	17
9.5 RECOMMENDED SOFTWARE INITIALIZATION	17
10 PACKAGE SPECIFICATION	18
11 RELIABILITY	19
11.1 RELIABILITY TEST.....	19
11.2 LIFETIME.....	19
11.3 FAILURE CHECK STANDARD.....	20
12 ILLUSTRATION OF OLED PRODUCT NAME	20
13 OUTGOING QUALITY CONTROL SPECIFICATIONS	21
13.1 SAMPLING METHOD	21
13.2 INSPECTION CONDITIONS	21
13.3 QUALITY ASSURANCE ZONES.....	21
13.4 INSPECTION STANDARD.....	22
14 PRECAUTIONS FOR OPERATION AND STORAGE	25
14.1 PRECAUTIONS FOR OPERATION	25
14.2 SOLDERING	25
14.3 PRECAUTIONS FOR STORAGE.....	25
14.4 WARRANTY PERIOD.....	25

REVISION RECORD

REV.	REVISION DESCRIPTION	REV. DATE	REMARK
A01	Initial release	2013-06-17	
D01	Modify “Visionox Display Co., Ltd” to “Visionox”	2014-02-19	Page 25

1 Overview

VGM128064C1A04 is an area color OLED display module with 128×64 dot matrix. The characteristics of this display module are high brightness, self-emission, high contrast ratio, slim/thin outline, wide viewing angle, wide temperature range, and low power consumption.

2 Features

- Display Color: Yellow & Blue
- Dot Matrix: 128×64
- Driver IC: SP5010
- Interface: 8-bit 8080
- Wide range of operating temperature: -40°C to 70°C

3 Mechanical Data

NO.	ITEM	SPECIFICATION	UNIT
1	Dot Matrix	128(W)×64(H)	-
2	Dot Size	0.15(W)×0.15 (H)	mm ²
3	Dot Pitch	0.17(W)×0.17 (H)	mm ²
4	Aperture Rate	77	%
5	Active Area	21.74(W)×11.2 (H)	mm ²
6	Panel Size	26.7(W)×19.26 (H) ×1.05 (T)	mm ³
7	Module Size	26.7(W)×34.86(H) ×1.28 (T)	mm ³
8	Diagonal A/A Size	0.96	inch
9	Module Weight	1.31±10%	gram

4 Mechanical Drawing

如本印章非红色, 则表明该文件为非受控版本, 不会受到控制和更新, 请使用受控文件.
 受控章
 分发号:

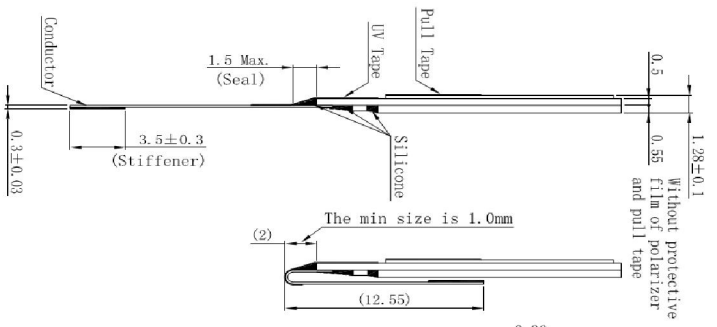
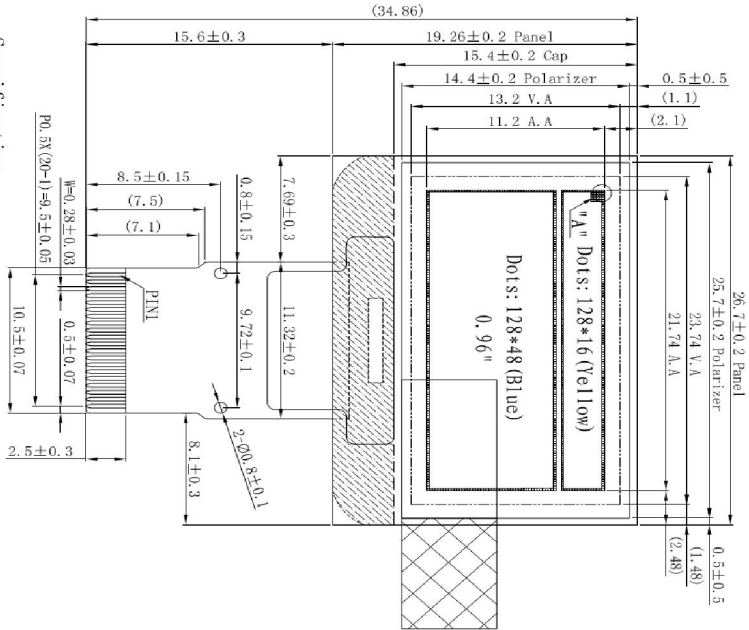

Detail A (20:1)

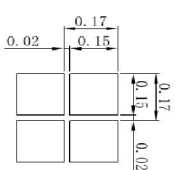

CONSECC Layout

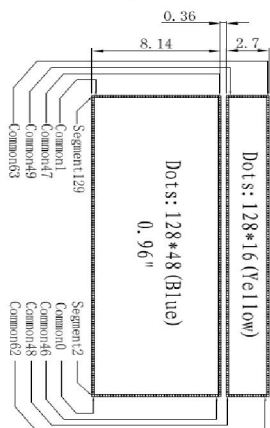

- Specification
1. Display: OLED(Y/B)
 2. Format: 128*64
 3. Driver IC: SP5010
 4. General Tolerance: ±0.3
 5. Operate temp: -40°C~70°C
 - Storage temp: -40°C~85°C
 6. DUTY: 1/64
 7. RoHS Compliant

Customer Approval		Date		Rev.		Unit		Sheet	
Signature		2013.03.25		01		mm		1/1	
Part Name		DES'D BY		CHK'D BY		CHK'D BY		APPROVED	
Module ass'y		00873		00873-MA1-A					
Project Code		Part No.							
00873		00873-MA1-A							

Rev.	Date	Note
1	2013.03.25	Base on 00870: Modify the PVC
2		

NO.	SYMBOL	Pin Assignment
1	VSS	
2	VSS	
3	VDD1	
4	/CS	
5	/RES	
6	A0	
7	/WR	
8	/RD	
9	VCOMH	
10	VPP	
11	D0	
12	D1	
13	D2	
14	D3	
15	D4	
16	D5	
17	D6	
18	D7	
19	TRF	
20	NC	



5 Module Interface

PIN NO.	PIN NAME	DESCRIPTION
1	VSS	Ground.
2	VSS	Ground.
3	VDD1	Power supply output for pad option:1.65-3.5V
4	/CS	This pad is the chip select input.When CS ="L",then the chip select becomes active, And data/command I/O is enabled.
5	/RES	This is a reset signal input pad.Then RES is set to "L",the settings are initialized. The reset operation is performed by the RES signal level.
6	A0	This is the data/command control pad that determines whether the data bits are data or a command. A0="H":the inputs at D0 to D7 are treated as display data. A0="L":the inputs at D0 to D7 are transferred to the command registers. In I ² C interface, this pad serves as SA0 to distinguish the different address of OLED driver
7	/WR	This is a MPU interface input pad. When connected to an 8080 MPU,this is active LOW.This pad connects to the 8080 MPU WR signal. The signals on the data bus are latched at the rising edge of the WR signal When WR ="H":Read. When WR ="L":Write.
8	/RD	This is a MPU interface input pad. When connected to an 8080 series MPU,it is active LOW.This pad is connected to the RD signal of the 8080 series MPU,and the SP5010 data bus is in an output status when this signal is "L". When RD ="H":Enable When RD ="L":Disable
9	VCOMH	This is a pad for the voltage output high level for common signals.
10	VPP	This is the most positive voltage supply pad of the chip It should be supplied externally
11~18	D0~D7	This is an 8-bit bi-directional data bus that connects to an 8-bit standard MPU data bus When the serial interface is selected,then D0 serves as the serial clock input pad (SCL) and D1 serves as the serial data input pad (SI). At this time,D2 to D7 are set to high impedance. When the I ² C interface is selected,then D0 serves as the serial clock input pad (SCL) and D1 serves as the serial data input pad (SDA). At this time,D2to D7 are set to high impedance
19	IREF	This is a segment current reference pad. A resistor should be connected between this pad and VSS.Set the current at 10uA
20	NC	No Connection.

6 Function Block Diagram

6.1 Function Block Diagram

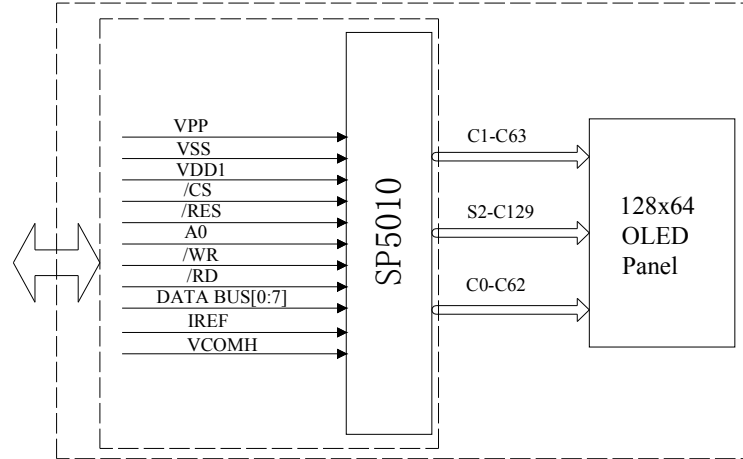

6.2 Panel Layout Diagram

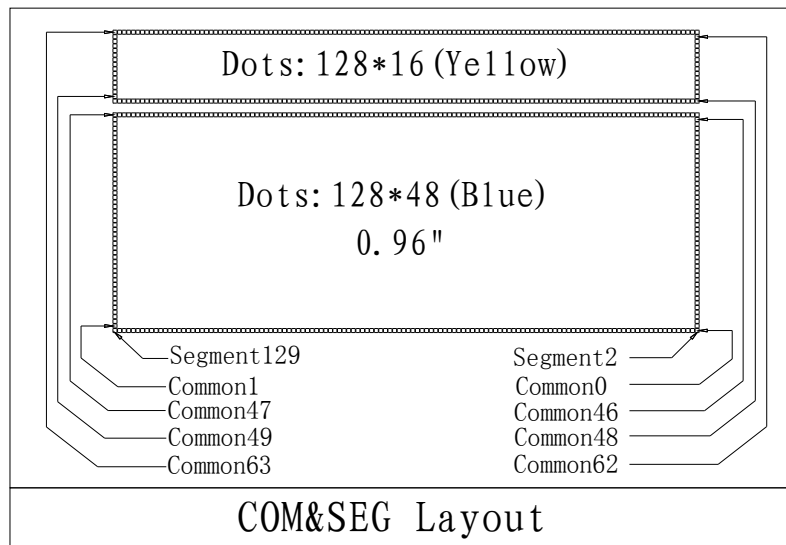

7 Absolute Maximum Ratings

ITEM	SYMBOL	MIN	MAX	UNIT	REMARK
DC Supply Voltage	VDD1	-0.3	+3.6	V	IC maximum rating
OLED Operating voltage	VPP	0	+13	V	IC maximum rating
Operating Temp.	Top	-40	+70	°C	-
Storage Temp	Tstg	-40	+85	°C	-

Note (1): All of the voltages are on the basis of “VSS = 0V”.

Note (2): Permanent breakage of module may occur if the module is used beyond the maximum rating. The module can be normal operated under the conditions according to Section 8 “Electrical Characteristics”. Malfunctioning of the module may occur and the reliability of the module may deteriorate if the module is used beyond the conditions.

8 Electrical Characteristics

8.1 DC Electrical Characteristics

ITEM	SYMBOL	TEST CONDITION	MIN	TYP	MAX	UNIT
Logic Supply Voltage	VDD1	22±3°C, 55±15%R.H	1.65	3.0	3.5	V
OLED Driver Supply Voltage	VPP	22±3°C, 55±15%R.H	9.5	10	10.5	V
High-level Input Voltage	V _{IH}	-	0.8×VDD1	-	VDD1	V
Low-level Input Voltage	V _{IL}	-	VSS	-	0.2×VDD1	V
High-level Output Voltage	V _{OH}	-	0.8×VDD1	-	VDD1	V
Low-level Output Voltage	V _{OL}	-	VSS	-	0.2×VDD1	V

Note : The VPP input must be kept in a stable value; ripple and noise are not allowed.

8.2 Electro-optical Characteristics

ITEM	SYMBOL	TEST CONDITION	MIN	TYP	MAX	UNIT	
Normal Mode Brightness	L _{br}	All pixels ON(1) VPP = 10V (External)	60	80	-	cd/m ²	
Sleep mode current Consumption in VDD1	ISP	During sleep,TA=+25°C VDD1=3V	-	0.02	10	uA	
Sleep mode current Consumption in VPP		During sleep,TA=+25°C VPP=9V(2)	-	0.02	10	uA	
Normal Mode Power Consumption	Pt	All pixels ON(1) VPP = 10V (External)	-	110	140	mW	
C.I.E(Y&B)	Yellow	x,y(CIE1931)	(x)	0.47	0.51	0.55	-
			(y)	0.44	0.48	0.52	-
	Blue		(x)	0.12	0.16	0.20	-
			(y)	0.23	0.27	0.31	-
Dark Room Contrast	CR	-	≥2000:1	-	-	-	
Response Time	-	-	-	10	-	μs	
View Angle	-	-	≥160	-	-	Degree	

Note(1):

Normal Mode test conditions are as follows:

- Driving voltage : 10V (VPP Supplied Externally).
- Contrast setting : 0x35
- Frame rate : 104Hz
- Duty setting : 1/64

Note(2):

Sleep Mode test conditions are as follows:

- Set \Display OFF:0XAE

Sleep mode:

This mode stops every operation of the OLED display system, and can reduce current consumption nearly to a static current value if no access is made from the microprocessor. The internal status in the sleep mode is as follows:

- Stops the oscillator circuit and DC-DC circuit.
- Stops the OLED drive and outputs HZ as the segment/common driver output.
- Holds the display data and operation mode provided before the start of the sleep mode.
- The MPU can access to the built-in display RAM.

8.3 AC Electrical Characteristics

(1)8080-Series MPU Parallel Interface Timing Characteristics

(VDD1 = 1.65V to 3.5V, TA = 25°C)

Symbol	Parameter	Min.	Typ.	Max.	Unit	Condition
tcyc8	System cycle time	600	-	-	ns	
tAS8	Address setup time	0	-	-	ns	
tAH8	Address hold time	0	-	-	ns	
tDS8	Data setup time	80	-	-	ns	
tDH8	Data hold time	30	-	-	ns	
tCH8	Output disable time	20	-	140	ns	CL = 100pF
tACC8	\overline{RD} access time	-	-	280	ns	CL = 100pF
tcCLW	Control L pulse width (WR)	200	-	-	ns	
tcCLR	Control L pulse width (RD)	240	-	-	ns	
tcCHW	Control H pulse width (WR)	200	-	-	ns	
tcCHR	Control H pulse width (RD)	200	-	-	ns	
tR	Rise time	-	-	30	ns	
tF	Fall time	-	-	30	ns	

(VDD1 = 2.4V to 3.5V, TA = 25°C)

Symbol	Parameter	Min.	Typ.	Max.	Unit	Condition
tcyc8	System cycle time	300	-	-	ns	
tAS8	Address setup time	0	-	-	ns	
tAH8	Address hold time	0	-	-	ns	
tDS8	Data setup time	40	-	-	ns	
tDH8	Data hold time	15	-	-	ns	
tCH8	Output disable time	10	-	70	ns	CL = 100pF
tACC8	\overline{RD} access time	-	-	140	ns	CL = 100pF
tcCLW	Control L pulse width (WR)	100	-	-	ns	
tcCLR	Control L pulse width (RD)	120	-	-	ns	
tcCHW	Control H pulse width (WR)	100	-	-	ns	
tcCHR	Control H pulse width (RD)	100	-	-	ns	
tR	Rise time	-	-	15	ns	
tF	Fall time	-	-	15	ns	

8080-series parallel interface characteristics

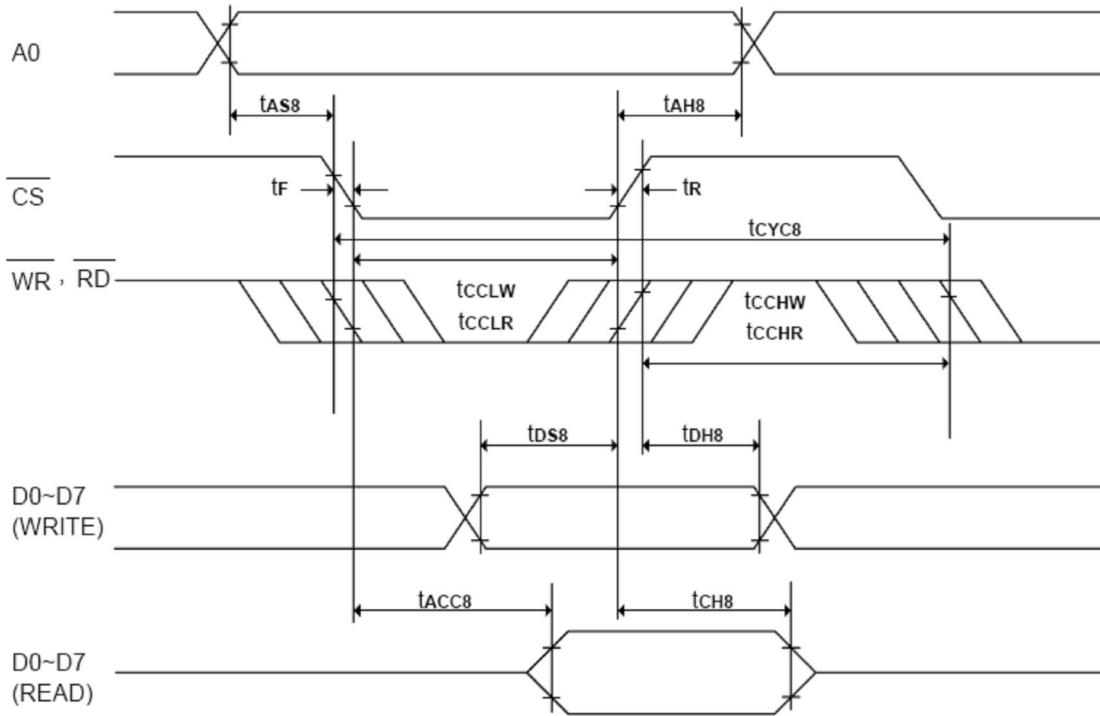

9 Functional Specification and Application Circuit

9.1 Power ON and Power OFF Sequence

9.1.1. Built-in DC-DC pump power is being used immediately after turning on the power:

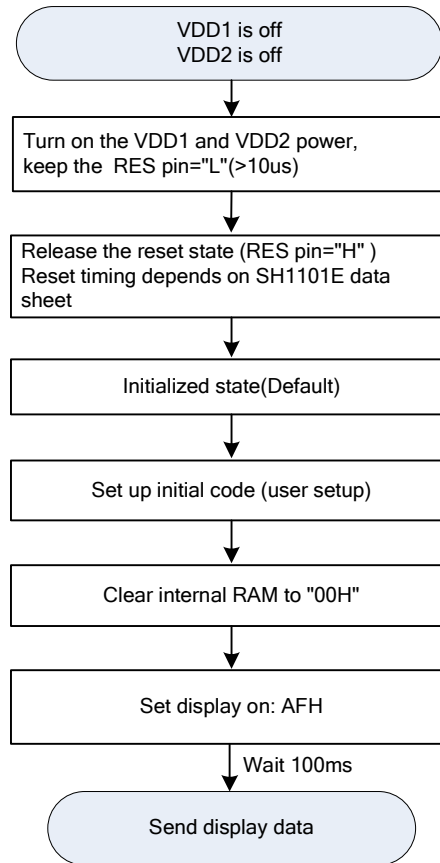

Power ON Sequence:

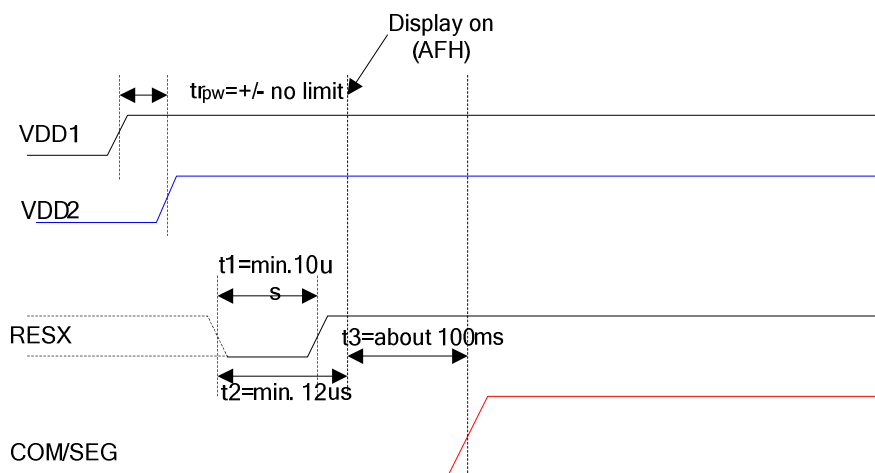

9.1.2. External power is being used immediately after turning on the power:

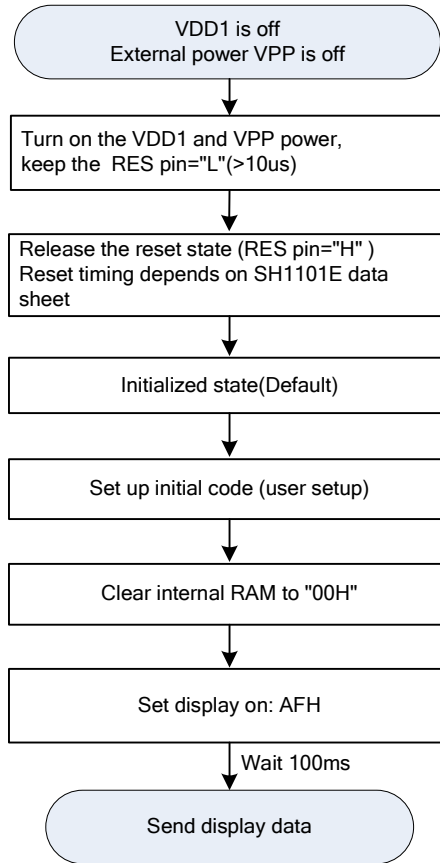

Power ON Sequence:

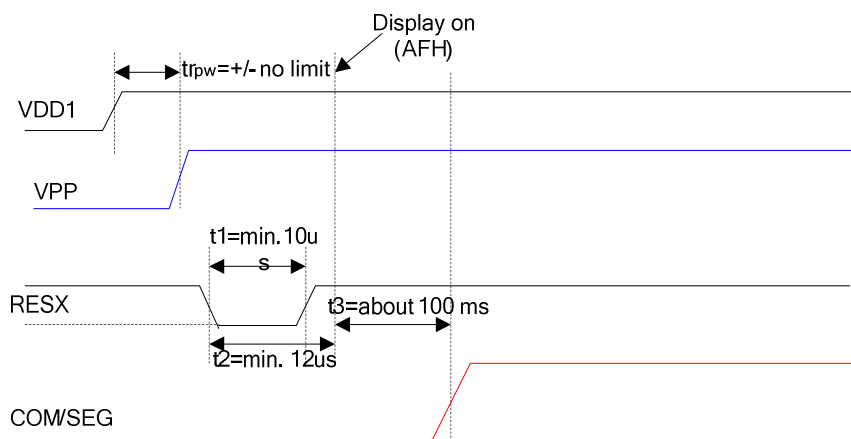

9.1.3 Power OFF

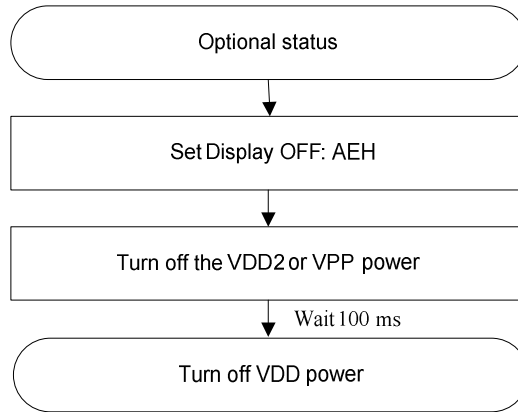

Power OFF Sequence:



9.2 Application Circuit

(1).The configuration for 8080-parallel interface mode, external V_{pp} is shown in the following diagram:

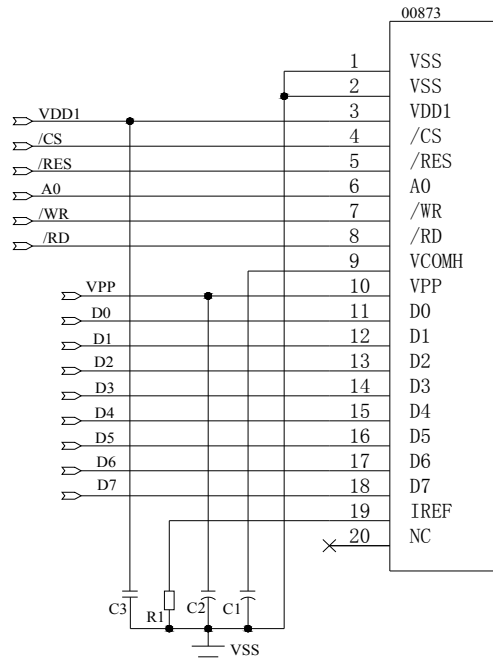

Pin connected to MCU interface: D[7:0], /RD, /WR, A0, /RES,/CS

Recommended components

C1, C2: 4.7 μ F/25V.ROHS (Tantalum Capacitors)

C3: 0.1 μ F-0603-X7R \pm 10%.ROHS

R1: 0603 1/10W \pm 5% 910Kohm.ROHS

9.3 External DC-DC application circuit

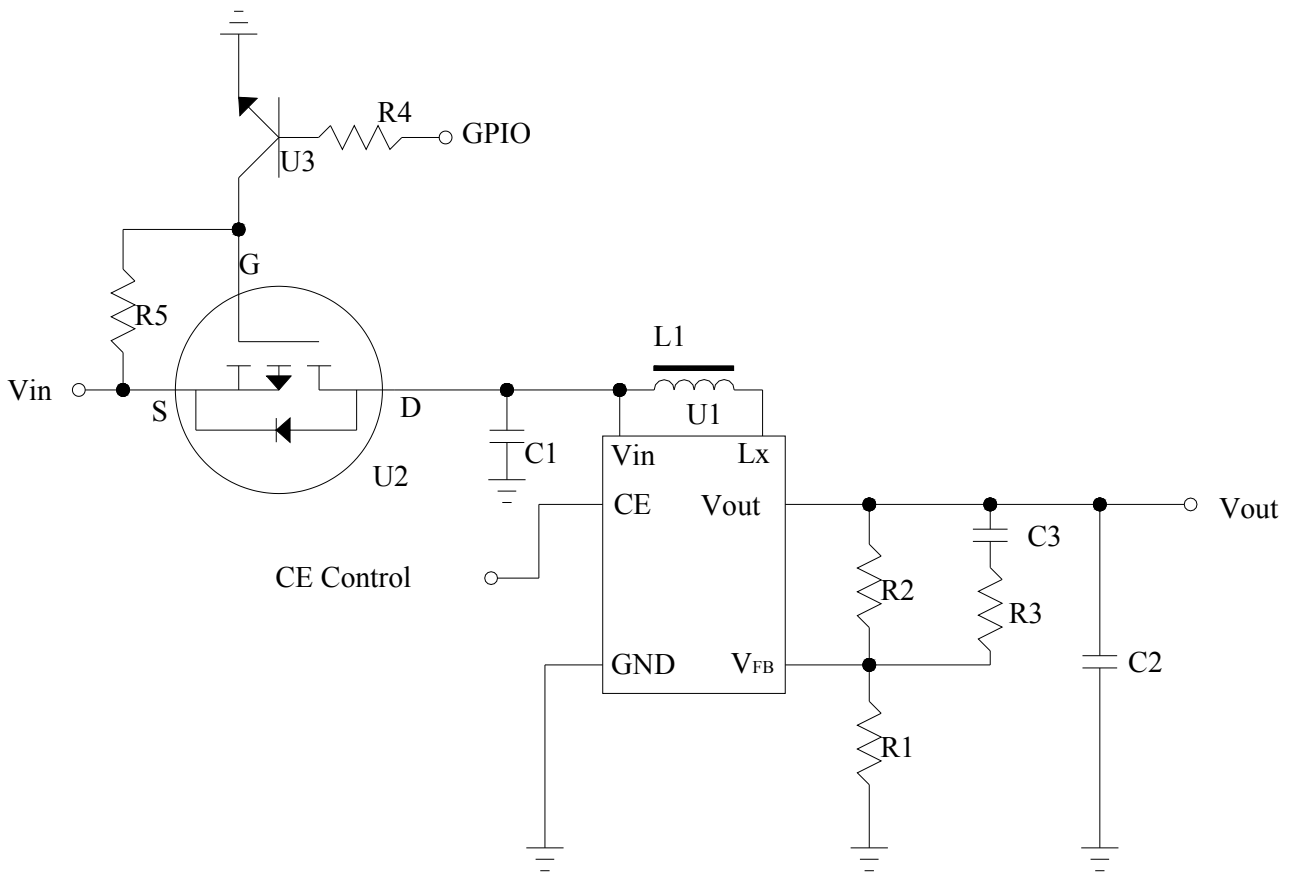

Recommend component

The C1	: 1 uF-0603-X7R±10%.ROHS
The C2	: 1 uF-0603-X7R±10%.ROHS
The C3	: 220pF-0603-X7R±10%.ROHS
The R1	: 0603 1/10W +/-1% 10Kohm.ROHS
The R2	: 0603 1/10W +/-1% 91Kohm.ROHS
The R3	: 0603 1/10W +/-5% 2Kohm.ROHS
The R4	: 0603 1/10W +/-5% 1Kohm.ROHS
The R5	: 0603 1/10W +/-5% 10Kohm.ROHS
The L1	: 22uH
The U1	: R1200
The U2	: FDN338P
The U3	: 8050

9.4 Display Control Instruction



Refer to SP5010 IC Specification.

9.5 Recommended Software Initialization

```
void Init_IC()
{
    Write_Command(0xae);           // Display off
    Write_Command(0xd5);           //Set Display Clock Divide Ratio/Oscillator Frequency
    Write_Command(0x50);           //104HZ
    Write_Command(0xa8);           //Set Multiplex Ratio
    Write_Command(0x3f);           //Set 64 mux
    Write_Command(0xd9);           //Set Pre-charge Period
    Write_Command(0x22);           //
    Write_Command(0xc8);           //COM scan direction COM(N-1)-->COM0
    Write_Command(0xda);           //Set COM Pins Hardware Configuration
    Write_Command(0x12);           //
    Write_Command(0x81);           //Set Contrast Control
    Write_Command(0x35);           //
    Write_Command(0xb0);           //Set Page Address
    Write_Command(0x10);           //Set Higher Column Address
    Write_Command(0x02);           //Set Lower Column Address
    Write_Command(0xd3);           //Set Display offset
    Write_Command(0x00);           //
    Write_Command(0xa1);           //Set Segment Re-map
    Write_Command(0x40);           //Set Display Start Line
    Write_Command(0xa6);           //Display Normal
    Write_Command(0xa4);           //Entire Display Off
    Write_Command(0xad);           //Set DC-DC OFF/ON
    Write_Command(0x8a);           //0x8a:OFF    //0x8b:ON
    Write_Command(0xdb);           //Set VCOMH Level
    Write_Command(0x35);           //0.77*VCC
    Write_Command(0xaf);           //Display on
}
```

Controlled Seal

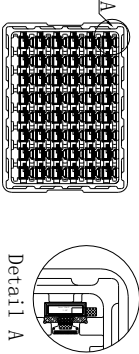
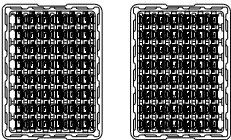
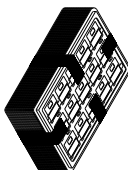
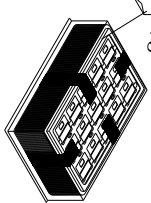
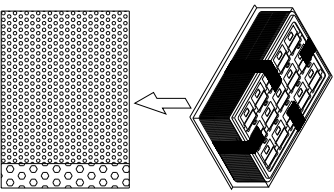
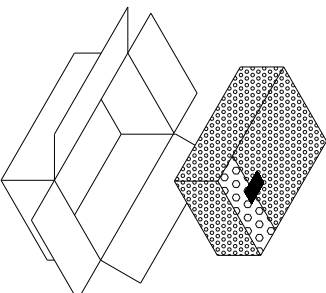
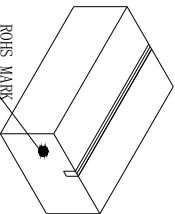
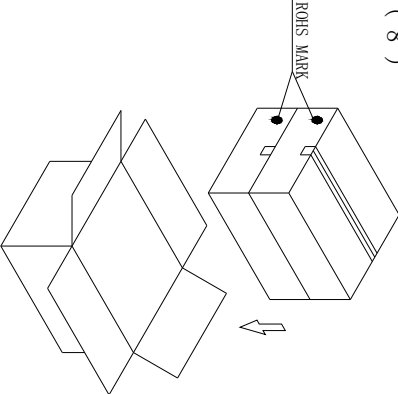
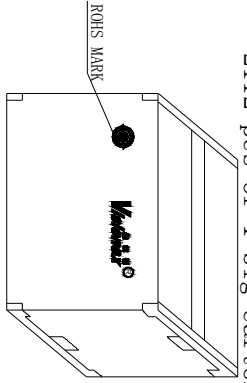
Packing Process (1) ~ (9)

<p>(1) Tray Type:00693-MT6-A</p> 	<p>(2)</p>  <p>normal ①</p> <p>180° revers ②</p> <p>TRAY</p>	<p>(3) order ①、② ①、②</p> <p>fix trays with tape</p> <p>1056 pcs of 1 small carton</p> <p>1 tray contain 48 pcs</p> <p>22 contained trays, 1 empty tray</p> 	<p>(4) Use vacuum bag to package the tray and add 5 bags of desiccant into the vacuum bag</p> <p>*5</p> 
<p>(5) After tray be packaged, wrap the package in a bubble bag and seal with scotch tape.</p> 	<p>(6)</p> 	<p>(7)</p> <p>small carton package</p> <p>L390*W290*L120 mm</p> 	<p>(8)</p> <p>2 small cartons in 1 big carton</p> 
<p>(9) M4 contained trays, 2 empty trays, Package quantity products: 2112 pcs of 1 big carton</p>  <p>Package finished</p> <p>L410*W310*L272 mm</p>	<p>NOTE:1、The inner carton and master carton must be sealed with adhesive tape.</p> <p>2、Fill up the gap with tray.</p> <p>3、If the customer has special needs with the RoHS making, the inner carton and master carton need adhesive new RoHS marking at  .</p>		

11 Reliability

11.1 Reliability Test

NO.	ITEM	CONDITION	QUANTITY
1	High Temperature (Non-operation)	85°C,240hrs	4
2	Low Temperature (Non-operation)	-40°C,240hrs	4
3	High Temperature (Operation)	70°C,240hrs	4
4	Low Temperature (Operation)	-40°C,240hrs	4
5	High Temperature / High Humidity (Operation)	60°C,90%RH,240hrs	4
6	Thermal shock (Non-operation)	-40°C~85°C(-40°C/30min;transit/3min;85°C/30min;transit/3min) 1cycle: 66min,30cycles	4
7	Vibration	Frequency: 5~50Hz,0.5G Scan rate: 1 oct/min Time: 2 hrs/axis Test axis: X,Y, Z	1 Carton
8	Drop	Height: 100 cm Sequence: 1 angle, 3 edges and 6 faces	1 Carton

Test and measurement conditions

1. All measurements shall not be started until the specimens attain to temperature stability, the stable time is at least 15 minutes.
2. The degradation of polarizer is ignored for item 5.
3. The tolerance of temperature is $\pm 3^{\circ}\text{C}$, and the tolerance of relative humidity is $\pm 5\%$.

Evaluation criteria

1. The function test is OK.
2. No observable defects.
3. Luminance: $\geq 50\%$ of initial value.
4. Current consumption: within $\pm 50\%$ of initial value.

11.2 Lifetime

End of lifetime is specified as 50% of initial brightness and the test pattern at operating condition is 50% alternating checkerboard.

ITEM	MIN	MAX	UNIT	CONDITION
Operation Life Time	10,000	-	hrs	80 cd/m ² ,50% Checkerboard 22±3°C, 55±15% RH

11.3 Failure Check Standard

After the completion of the described reliability test, the samples were left at room temperature for 2 hrs prior to conducting the failure test at $22\pm 3^{\circ}\text{C}$; $55\pm 15\%$ RH.

12 Illustration of OLED Product Name

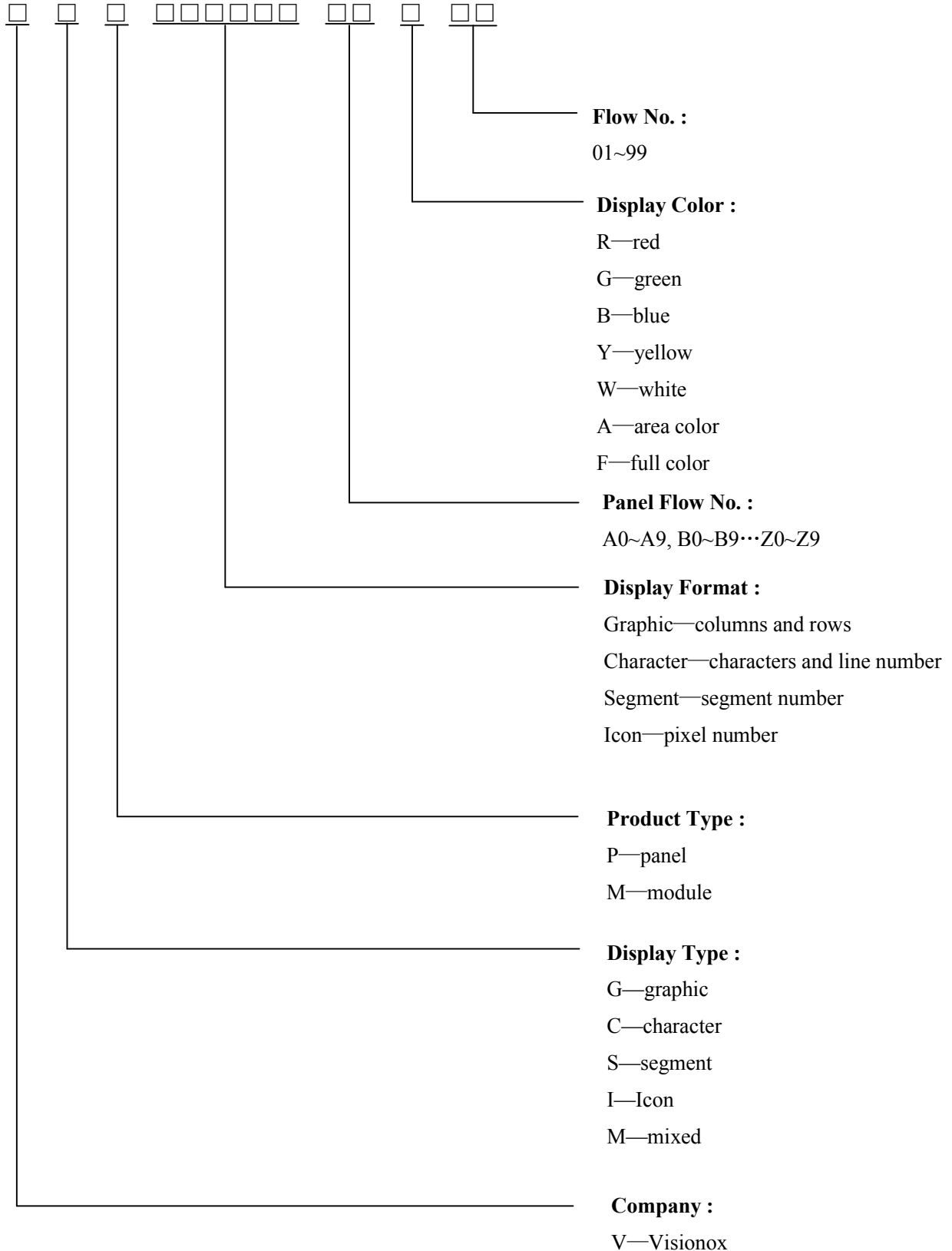

13 Outgoing Quality Control Specifications

13.1 Sampling Method

- (1) GB/T 2828.1-2003/ISO2859-1: 1999, inspection level II , normal inspection, single sample inspection
- (2) AQL: Major 0.65; Minor 1.0

13.2 Inspection Conditions

The environmental conditions for test and measurement are performed as follows.

Temperature: $22 \pm 3^{\circ}\text{C}$

Humidity: $55 \pm 15\% \text{R.H}$

Fluorescent Lamp: 30W

Distance between the Panel & Lamp: $\geq 50\text{cm}$

Distance between the Panel & Eyes: $\geq 30\text{cm}$

Viewing angle from the vertical in each direction: $\leq 45^{\circ}$

(See the sketch below)

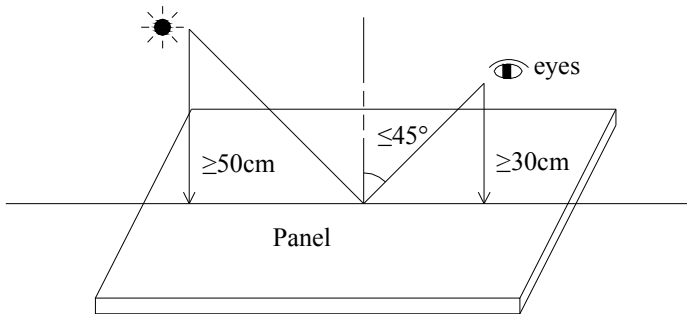

13.3 Quality Assurance Zones

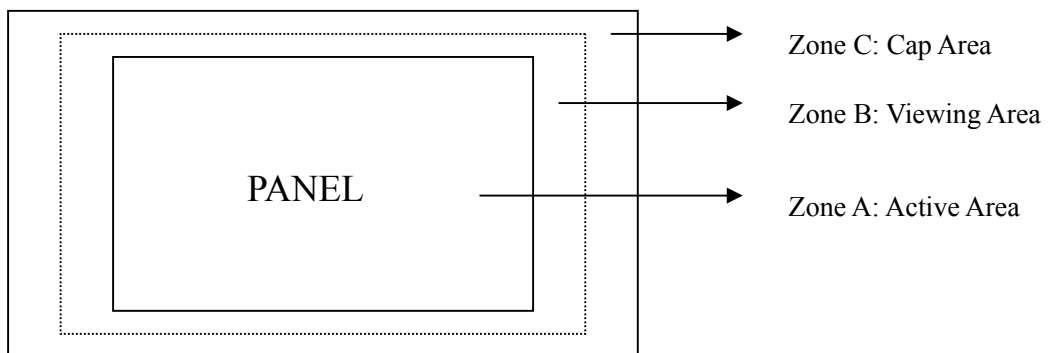

13.4 Inspection Standard

Definition of Φ &L&W (Unit: mm)

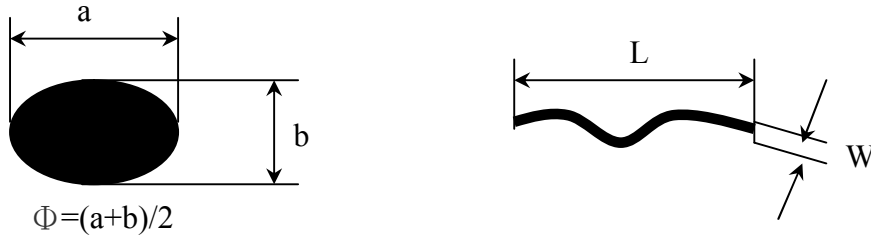

I . Appearance Defects

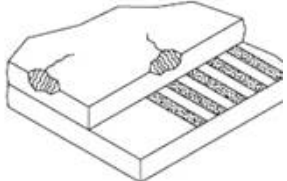
NO.	ITEM	CRITERIA	CLASSIFICATION																
1	Polarizer Black or White spot, Dirty spot, Foreign matter, Dent on the polarizer	<table border="1"> <thead> <tr> <th rowspan="2">Average Diameter (mm)</th> <th colspan="2">Acceptable Number</th> </tr> <tr> <th>Zone A,B</th> <th>Zone C</th> </tr> </thead> <tbody> <tr> <td>$\Phi \leq 0.15$</td> <td>Ignore</td> <td rowspan="3">Ignore</td> </tr> <tr> <td>$0.15 < \Phi \leq 0.30$</td> <td>3</td> </tr> <tr> <td>$\Phi > 0.30$</td> <td>0</td> </tr> </tbody> </table>	Average Diameter (mm)	Acceptable Number		Zone A,B	Zone C	$\Phi \leq 0.15$	Ignore	Ignore	$0.15 < \Phi \leq 0.30$	3	$\Phi > 0.30$	0	Minor				
Average Diameter (mm)	Acceptable Number																		
	Zone A,B	Zone C																	
$\Phi \leq 0.15$	Ignore	Ignore																	
$0.15 < \Phi \leq 0.30$	3																		
$\Phi > 0.30$	0																		
2	Scratch/line on the glass/Polarizer	<table border="1"> <thead> <tr> <th rowspan="2">Width (mm)</th> <th rowspan="2">Length (mm)</th> <th colspan="2">Acceptable Number</th> </tr> <tr> <th>Zone A,B</th> <th>Zone C</th> </tr> </thead> <tbody> <tr> <td>$W \leq 0.03$</td> <td>---</td> <td>Ignore</td> <td rowspan="3">Ignore</td> </tr> <tr> <td>$0.03 < W \leq 0.08$</td> <td>$L \leq 5.0$</td> <td>3</td> </tr> <tr> <td>$W > 0.08$</td> <td>---</td> <td>0</td> </tr> </tbody> </table>	Width (mm)	Length (mm)	Acceptable Number		Zone A,B	Zone C	$W \leq 0.03$	---	Ignore	Ignore	$0.03 < W \leq 0.08$	$L \leq 5.0$	3	$W > 0.08$	---	0	Minor
Width (mm)	Length (mm)	Acceptable Number																	
		Zone A,B	Zone C																
$W \leq 0.03$	---	Ignore	Ignore																
$0.03 < W \leq 0.08$	$L \leq 5.0$	3																	
$W > 0.08$	---	0																	
3	Polarizer Bubble	<table border="1"> <thead> <tr> <th rowspan="2">Average Diameter (mm)</th> <th colspan="2">Acceptable Number</th> </tr> <tr> <th>Zone A,B</th> <th>Zone C</th> </tr> </thead> <tbody> <tr> <td>$\Phi > 0.5$</td> <td>0</td> <td rowspan="3">Ignore</td> </tr> <tr> <td>$0.2 < \Phi \leq 0.5$</td> <td>3</td> </tr> <tr> <td>$\Phi \leq 0.2$</td> <td>Ignore</td> </tr> </tbody> </table>	Average Diameter (mm)	Acceptable Number		Zone A,B	Zone C	$\Phi > 0.5$	0	Ignore	$0.2 < \Phi \leq 0.5$	3	$\Phi \leq 0.2$	Ignore	Minor				
Average Diameter (mm)	Acceptable Number																		
	Zone A,B	Zone C																	
$\Phi > 0.5$	0	Ignore																	
$0.2 < \Phi \leq 0.5$	3																		
$\Phi \leq 0.2$	Ignore																		
4	Any Dirt & Scratch on Polarizer's Protective Film	Ignore for not affect the polarizer.	Acceptable																
5	Glass Crack	 <p>Propagation crack is not acceptable.</p>	Major																

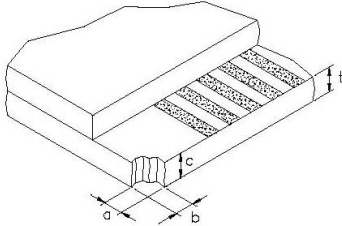
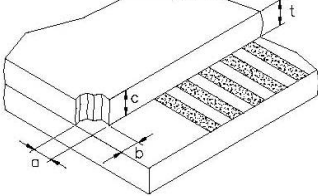
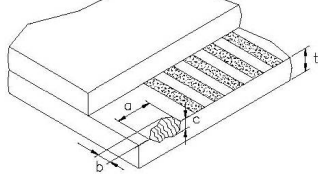
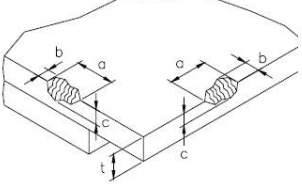
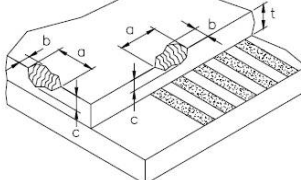
6	Corner Chip	 <p>t= Glass thickness Accept $a \leq 2.0\text{mm}$ or $b \leq 2.0\text{mm}$, $c \leq t$</p>	Minor
7	Corner Chip on Cap Glass	 <p>t= Glass thickness Accept $a \leq 1.5\text{mm}$ or $b \leq 1.5\text{mm}$, $c \leq t$</p>	Minor
8	Chip on Contact Pad	 <p>t= Glass thickness Accept $a \leq 3.0\text{mm}$ or $b \leq 0.8\text{mm}$, $c \leq t$ (on the contact pin) $a \leq 3.0\text{mm}$ or $b \leq 1.5\text{mm}$, $c \leq t$ (outside of the contact pin)</p>	Minor
9	Chip on Face of Display	 <p>t= Glass thickness Accept $a \leq 1.5\text{mm}$ or $b \leq 1.5\text{mm}$, $c \leq t$</p>	Minor
10	Chip on Cap Glass	 <p>t= Glass thickness Accept $a \leq 3.0\text{mm}$ or $b \leq 3.0\text{mm}$, $c \leq t/2$ $a \leq 1.5\text{mm}$ or $b \leq 1.5\text{mm}$, $t/2 \leq c \leq t$</p>	Minor
11	Stain on Surface	Stain removable by soft cloth or air blow is acceptable.	Minor
12	TCP/FPC Damage	<p>(1) Crack, deep scratch, deep hole and deep pressure mark on the TCP/FPC are not acceptable. (2) Terminal lead twisted or broken is not allowable. (3) Copper exposed is not allowed by naked eye inspection.</p>	Minor
13	Dimension Unconformity	Checking by mechanical drawing.	Major

II. Displaying Defects

NO.	ITEM	CRITERIA		CLASSIFICATION										
1	Black/White spot Dirty spot Foreign matter	Average Diameter (mm)	<table border="1"> <thead> <tr> <th colspan="2" data-bbox="794 371 1259 405">Pieces Permitted</th> </tr> <tr> <th data-bbox="794 405 1002 439">Zone A,B</th> <th data-bbox="1002 405 1259 439">Zone C</th> </tr> </thead> <tbody> <tr> <td data-bbox="794 439 1002 472">$\Phi \leq 0.10$</td> <td data-bbox="1002 439 1259 472">Ignore</td> </tr> <tr> <td data-bbox="794 472 1002 506">$0.10 < \Phi \leq 0.20$</td> <td data-bbox="1002 472 1259 506">3</td> </tr> <tr> <td data-bbox="794 506 1002 539">$\Phi > 0.20$</td> <td data-bbox="1002 506 1259 539">0</td> </tr> </tbody> </table>	Pieces Permitted		Zone A,B	Zone C	$\Phi \leq 0.10$	Ignore	$0.10 < \Phi \leq 0.20$	3	$\Phi > 0.20$	0	Minor
Pieces Permitted														
Zone A,B	Zone C													
$\Phi \leq 0.10$	Ignore													
$0.10 < \Phi \leq 0.20$	3													
$\Phi > 0.20$	0													
2	No Display	Not allowable.		Major										
3	Irregular Display	Not allowable.		Major										
4	Missing Line (row or column)	Not allowable.		Major										
5	Short	Not allowable.		Major										
6	Flicker	Not allowable.		Major										
7	Abnormal Color	Refer to the SPEC.		Major										
8	Luminance NG	Refer to the SPEC.		Major										
9	Over Current	Refer to the SPEC.		Major										

14 Precautions for operation and Storage

14.1 Precautions for Operation

- (1) Since OLED panel is made of glass, do not apply any mechanical shock or impact or excessive force to it when installing the OLED module. Any strong mechanical impact due to falling dropping etc. may cause damage (breakage or cracking).
- (2) The polarizer on the OLED surface is made of soft material and is easily scratched. Please take most care when handing. When the surface of the polarizer of OLED Module is contaminated, please wipe it off gently by using moisten soft cloth with isopropyl alcohol, do not use water, ketone or aromatics. If there is saliva or water on the OLED surface, please wipe it off immediately.
- (3) When handling OLED module, please be sure that the body and the tools are properly grounded. And do not touch I/O pins with bare hands or contaminate I/O pins, it will cause disconnection or defective insulation of terminals.
- (4) Do not attempt to disassemble or process the OLED module.
- (5) OLED module should be used under recommended operating conditions shown in the specification. Since the higher voltage leads to the shorter lifetime, be sure to use the specified operating voltage.
- (6) Foggy dew, moisture condensation or water droplets deposited on surface and contact terminals will cause polarizer stain or damage, the deteriorated display quality and electrochemical reaction then leads to shorter life time and permanent damage to the module probably. Please pay attention to the environmental temperature and humidity.
- (7) An afterimage is created by the difference in brightness between unused dot and the fixed dot, according to the decrease of brightness of the emitting time. Therefore, to avoid having an afterimage, the full set should be thoroughly used instead of using a fixed dot. When the fixed dot emits, an afterimage can be created.
- (8) Flicker could be come out at full on display. And it disappears when frame frequency increase, but brightness decreases too.

14.2 Soldering

- (1) Soldering should be performed only on the I/O terminals.
- (2) Use soldering irons with proper grounding and no leakage.
- (3) Iron: no higher than 300°C and 3~4 sec during soldering.

14.3 Precautions for Storage

- (1) Please store OLED module in a dark place. Avoid exposure to sunlight, the light of fluorescent lamp or any ultraviolet ray.
- (2) Keep the environment temperature between 10°C and 35°C and the relative humidity less than 60%. Avoid high temperature and high humidity.
- (3) Keep the OLED modules stored in the container when shipped from supplier before using them is recommended.
- (4) Do not leave any article on the OLED module surface for an extended period of time.

14.4 Warranty period

Visionox warrants for a period of 12 months from the shipping date when stored or used under normal condition.

Компания «Океан Электроники» предлагает заключение долгосрочных отношений при поставках импортных электронных компонентов на взаимовыгодных условиях!

Наши преимущества:

- Поставка оригинальных импортных электронных компонентов напрямую с производств Америки, Европы и Азии, а так же с крупнейших складов мира;
- Широкая линейка поставок активных и пассивных импортных электронных компонентов (более 30 млн. наименований);
- Поставка сложных, дефицитных, либо снятых с производства позиций;
- Оперативные сроки поставки под заказ (от 5 рабочих дней);
- Экспресс доставка в любую точку России;
- Помощь Конструкторского Отдела и консультации квалифицированных инженеров;
- Техническая поддержка проекта, помощь в подборе аналогов, поставка прототипов;
- Поставка электронных компонентов под контролем ВП;
- Система менеджмента качества сертифицирована по Международному стандарту ISO 9001;
- При необходимости вся продукция военного и аэрокосмического назначения проходит испытания и сертификацию в лаборатории (по согласованию с заказчиком);
- Поставка специализированных компонентов военного и аэрокосмического уровня качества (Xilinx, Altera, Analog Devices, Intersil, Interpoint, Microsemi, Actel, Aeroflex, Peregrine, VPT, Syfer, Eurofarad, Texas Instruments, MS Kennedy, Miteq, Cobham, E2V, MA-COM, Hittite, Mini-Circuits, General Dynamics и др.);

Компания «Океан Электроники» является официальным дистрибьютором и эксклюзивным представителем в России одного из крупнейших производителей разъемов военного и аэрокосмического назначения «JONHON», а так же официальным дистрибьютором и эксклюзивным представителем в России производителя высокотехнологичных и надежных решений для передачи СВЧ сигналов «FORSTAR».



JONHON

«JONHON» (основан в 1970 г.)

Разъемы специального, военного и аэрокосмического назначения:

(Применяются в военной, авиационной, аэрокосмической, морской, железнодорожной, горно- и нефтедобывающей отраслях промышленности)

«FORSTAR» (основан в 1998 г.)

ВЧ соединители, коаксиальные кабели, кабельные сборки и микроволновые компоненты:

(Применяются в телекоммуникациях гражданского и специального назначения, в средствах связи, РЛС, а так же военной, авиационной и аэрокосмической отраслях промышленности).



Телефон: 8 (812) 309-75-97 (многоканальный)

Факс: 8 (812) 320-03-32

Электронная почта: ocean@oceanchips.ru

Web: <http://oceanchips.ru/>

Адрес: 198099, г. Санкт-Петербург, ул. Калинина, д. 2, корп. 4, лит. А