



### FEATURES

- Scientific-grade accuracy,  $\pm 2$  counts
- Low power, typically 12.5mW
- Miniature size:  
2.17" x 0.92" x 0.43" (55mm x 23mm x 11mm)
- Large (0.4"/10.2mm), enhanced-contrast, LCD display
- Backlit displays optional
- Epoxy-encapsulated, 12-pin DIP
- Panel or pc-board mountable
- 3 differential, dual, input voltage ranges
- Single +5V supply or 9V battery
- User-selectable decimal point placement
- Low-battery "BAT" annunciator
- 0 to +50°C temperature range
- Low Cost

Offering a unique combination of low cost, scientific-grade accuracy ( $\pm 2$  counts), component-like convenience and outstanding reliability, DMS-40LCD Series 4½ Digit DPM's provide the ultimate combination of price, precision and convenience. These miniature (2.17" x 0.92" x 0.43") digital voltmeters combine an advanced, autozeroing A/D converter, a precision reference circuit and a large (0.4"/10.2mm high), easy-to-read LCD display in a single, fully encapsulated, 12-pin DIP package. All models incorporate a built-in bezel and are easily mounted in either panels or pc boards.

Each DMS-40LCD meter has a dual-range, differential, input configuration ( $\pm 200\text{mV}/\pm 2\text{V}$ ,  $\pm 2\text{V}/\pm 20\text{V}$  or  $\pm 20\text{V}/\pm 200\text{V}$ ) and is available with a backlit or non-backlit display. Input impedance is a minimum 800k $\Omega$ , and CMRR is typically 86dB (dc to 60Hz). CMV is  $\pm 2\text{V}$ , and all models are overvoltage protected to  $\pm 250\text{V}$  (on their non-inverting inputs).

All DMS-40LCD meters are fully functional and operate from a single +5V supply (drawing 3.5mA max.) or a single 9V supply/battery (drawing 2.5mA max.). All models feature autopolarity changeover and overrange indication. A display HOLD function is standard on all non-backlit models.

Thanks to their rugged epoxy-based encapsulation and their advanced, factory-calibrated A/D converters, DMS-40LCD meters are able to withstand the harshest environments and never require adjustment or calibration. Plug-in convenience, long-term stability and wide operating temperature range (0 to +50°C) make DMS-40LCD meters the right solution for any high-accuracy DPM requirement.

### SIMPLIFIED SCHEMATIC DIAGRAM

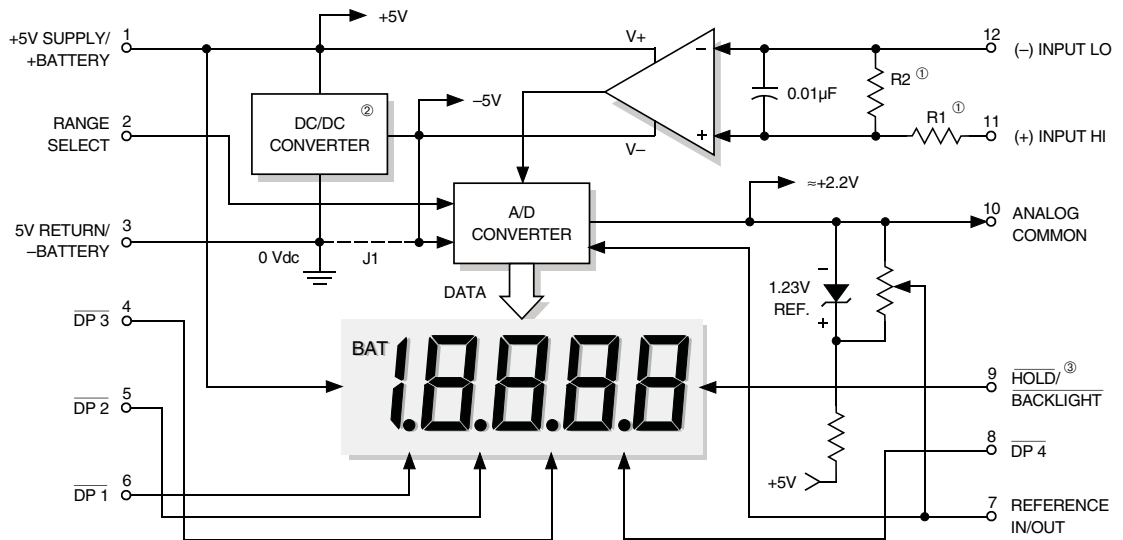

- ① R1 = 100k on  $\pm 200\text{mV}/\pm 2\text{V}$  (-0/1) models and 909k on all other models.
- R2 is not used on  $\pm 200\text{mV}/\pm 2\text{V}$  (-0/1) models.
- R2 = 101k on  $\pm 2\text{V}/\pm 20\text{V}$  (-1/2) models and 9.2k on  $\pm 20\text{V}/\pm 200\text{V}$  (-2/3) models.

- ② DC/DC converter is not used on 9V-powered models, J1 is connected.
- ③ Hold function is not available on backlit models.



### Performance/Functional Specifications

Typical at T<sub>A</sub> = +25°C and supply voltage = +5V (using the single-ended input circuit) or +9V (using the differential input circuit), unless otherwise noted.

Analog Inputs	Min.	Typ.	Max.	Units
<b>Full Scale Input Range:</b> ①				
DMS-40LCD-0/1	–	±200/±2	–	mV/V
DMS-40LCD-1/2	–	±2/±20	–	V/V
DMS-40LCD-2/3	–	±20/±200	–	V/V
<b>Input Impedence:</b>				
DMS-40LCD-0/1	100	1000		MΩ
DMS-40LCD-1/2	0.8	1	–	MΩ
DMS-40LCD-2/3	0.8	1	–	MΩ
<b>Overvoltage Protection</b> ②				
	–	–	±250	Volts
<b>Common Mode Voltage Range</b> ③				
	–	–	±2	Volts
<b>CMRR (dc to 60Hz)</b>				
	–	86	–	dB
<b>Control Inputs</b> ④				
<b>Decimal Pt. Placement</b> (Pins 4-6, 8): Functionality Logic Compatibility	Tie to pin 3 to activate TTL (on 5V-powered models)			
<b>Hold/Backlight Functionally</b> (Pin 9) Backlit Models Non-backlit Models	Tie to pin 1 to activate Tie to pin 3 to hold reading			
<b>Performance</b>				
<b>Sampling Rate</b>	2.5 reading per second			
<b>Accuracy (1 minute warm-up):</b>				
DMS-40LCD-0/1 (Vin = +0.19/1.9V)	–	±2	±3	Counts
DMS-40LCD-1/2 (Vin = +1.9V)	–	±2	±3	Counts
DMS-40LCD-1/2 (Vin = +19V)	–	±3	±4	Counts
DMS-40LCD-2/3 (Vin = +19/190V)	–	±3	±4	Counts
<b>Zero Reading</b> (Vin = 0 Volts)	“–001”	“000”	“001”	
<b>Temperature Drift</b> (0 = +50°C)				
DMS-40LCD-0/1	–	±0.4	±0.8	Cnts/°C
DMS-40LCD-1/2	–	±0.6	±1	Cnts/°C
DMS-40LCD-2/3	–	±0.6	±1	Cnts/°C
<b>Power Supply Requirements (5V Models)</b>				
<b>Supply Voltage</b>	+4.75	+5.00	+5.25	Volts
<b>Supply Current:</b>				
Standard Models	–	+2.5	+3.5	mA
Backlit Models	–	+37	+45	mA
<b>Power Supply Requirements (9V Models)</b>				
<b>Supply Voltage</b>	+7.5	+9.00	+14.0	Volts
<b>Supply Current:</b>				
Standard Models	–	+1.5	+2.5	mA
Backlit Models	–	+37	+45	mA
<b>Display</b>				
<b>Display Type and Size</b>	4½ digit, 0.4"/10.2mm high LCD			
<b>Polarity Indication</b>	Autopolarity (“–” for negative Vin)			
<b>Overrange Indication</b>	“–1____” for negative inputs “1____” for positive inputs			

Physical/Environmental				
<b>Operating Temperature</b>	0	–	+50	°C
<b>Storage Temperature</b>	–20	–	+75	°C
<b>Humidity (non-condensing)</b>	0	–	95	%
<b>Case Material</b>	Polycarbonate			
<b>Weight</b>	0.75 ounces (21 grams)			

① Each model in the DMS-40LCD Series offers two input voltage ranges that are user-selectable via pin strapping. 5V-powered models can be used to perform either differential or single-ended measurements. 9V-powered models can only be used for differential measurements.

② Applies for transient or continuous overvoltages applied to (+) INPUT HI (pin 11) with (–) INPUT LO (pin 12) properly connected. Pin 12 is not overvoltage protected (see Figure 1). Voltages applied to pin 12 should not exceed the supply voltage.

③ Listed spec applies to 5V-powered models only. For 9V-powered models, both (–) INPUT LO (pin 12) and (+) INPUT HIGH (pin 11) must always be at least 1.5V above –BATTERY (pin 3) and at least 1.5V below +BATTERY (pin 1).

④ See Technical Notes.

### Ordering Information

#### DMS-40LCD - 0/1 - 5 -C

**Input Ranges:**

0/1 = ±200mV/±2V  
1/2 = ±2V/±20V  
2/3 = ±20V/±200V

**Power Source:**

5 = +5V  
9 = +9V

Add -C for RoHS

Leave blank for standard models. Add B for backlit models.

**Accessories:**

**DMS-30-CP** Panel cutout punch  
**DMS-BZL1-C** DMS-40 bezel assembly  
**DMS-BZL2-C** DMS-40 bezel assembly with sealing gasket  
**DMS-EB-C** Application/evaluation board with standard MOLEX connector, decimal point solder pads and attenuation resistor pads.

A panel-mount retaining clip is supplied with each model.

### TECHNICAL NOTES

- 1. Input Voltage Range Selection:** Each model in the DMS-40LCD Series offers two, user-selectable, input voltage ranges as indicated in the Performance/Functional Specifications Table and the Ordering Information. To select the higher range of any device (such as the ±2V range for the DMS-40LCD-0/1), connect pin 2 (RANGE SELECT) to pin 1 (+5V SUPPLY/+BATTERY). To select the lower range, leave pin 2 open.
- 2. Decimal Point Placement:** The location of the decimal point is user-selectable, and the decimal point control pins (DP1-DP4) are active low functions. Select the appropriate decimal point by tying the appropriate pin (pin 4, 5, 6 or 8) to pin 3 (5V RETURN/–BATTERY). Unused decimal point location pins should be left open. For 5V-powered models, the decimal location pins are TTL compatible and may be hard wired as described above or driven with 5V TTL logic gates.

- 3. Low Battery Annunciator:** The “BAT” annunciator in the upper left-hand corner of the display turns on when the supply voltage for 5V-powered models falls below the approximate range of 2.7V to 3.7V, or when the supply voltage for 9V-powered models falls below the approximate range of 5.4 to 7.2V. This function can not be disabled.

Please note, the “BAT” annunciator is a convenience feature only. The supply voltage ranges specified previously in the ‘Performance/Functional Specifications’ section of this data sheet must be maintained at all times in order to ensure the DMS-40LCD meets its accuracy and stability specifications.

- 4. HOLD/BACKLIGHT (Pin 9) Function:** For non-backlit models, connecting pin 9 (HOLD/BACKLIGHT) to pin 3 (5V RETURN/–BATTERY) will hold (continuously display) the last reading. If not used, pin 9 should be left open for these models.

For backlit models, grounding pin 9 (i.e. connecting it to pin 3) turns on the backlighting LED’s. 9V-powered backlit models function with supply voltages up to +14V, however, activating the backlight with voltages greater than 9.2V can damage the meter. Therefore, a 1/4 Watt series resistor must be installed between pins 3 and 9 in these situations. The value of the series resistor is determined using the following formula:

$$R_{\text{Series}} = \frac{+\text{BATTERY} - 9.2\text{V}}{0.035} \text{ Ohms}$$

Example: If +BATTERY (pin 1 with respect to pin 3) is +12.6V,

$$R_{\text{Series}} = \frac{+12.6 - 9.2\text{V}}{0.035} \text{ Ohms}$$

$$R_{\text{Series}} = 97 \text{ Ohms}$$

In any backlit application, including those with supply voltages < 9.2V, the current drawn by the backlight (and therefore the current drawn by the meter) can be reduced by installing a 1/4 Watt resistor between pins 3 and 9. The brightness of the backlight will be reduced proportionately.

- 5. ANALOG COMMON (Pin 10):** This pin is connected to an internal, low-noise, “relative” ground. It is used in certain “floating” measurements as described in the Applications section of this data sheet and Ap Note 3 of the DATEL Panel Meter Catalog. **Pin 10 should not be connected to pin 3 (5V RETURN/–BATTERY) or to your system’s analog ground.**
- 6. REFERENCE IN/OUT (Pin 7):** This pin accesses the meter’s internal reference and is used during the factory calibration procedure. Pin 7 should be left open in most common applications. It can be used in certain “ratiometric” applications in which it is desirable for the meter’s reference to track an external reference. See the Applications section of the DATEL Panel Meter Catalog for more details.
- 7. Gain Adjust:** There is a gain-adjust potentiometer on the back of each meter. It has approximately ±150 counts of adjustment range. Since these devices essentially have no zero/offset errors, a gain adjustment is effectively an overall accuracy adjustment. Though they may be performed at any point (except zero), accuracy adjustments are most effective when performed with higher level input signals.

- 8. Soldering Methods:** All models in the DMS-40LCD Series easily withstand most common wave soldering operations. We recommend, however, you evaluate the effects your particular soldering techniques may have on the meter’s plastic case and high-precision electrical performance. We recommend the use of no-clean solders.

**9. Suggested Mating Connectors:**

**Panel mounted:**

Connector housing	DATEL P/N 4320-01069-0
Terminal type	DATEL P/N 4400-01032-0
Crimping tool	DATEL P/N 39-2099000
Wire size	22 to 26 AWG
Insulation diameter	0.062” (1.57mm) maximum
Stripping length	0.100 to 0.125” (2.54 to 3.17mm)

**Board mounted:**

Socket	DATEL P/N 4320-01074-0
--------	------------------------

### APPLICATIONS

DMS-40LCD meters are available in either 5V-powered or 9V-powered models. 9V devices operate directly from 7.5V to 14V supplies (usually batteries) without the need for external voltage regulators. 9V devices, however, can not be used to measure voltages referenced to the negative battery terminal (pin 3) because the minus input to the meter (pin 12, (–) INPUT LO) must always be at least 1.5V above pin 3. 9V-powered meters can only be used to make differential and not single-ended measurements.

5V-powered devices operate from any well-regulated +5V supply and will accurately measure voltages both above and below pin 3 (5V RETURN) in either single-ended or differential configurations.

- 1. Single-Ended Input Configurations:** True single-ended measurements can only be made with 5V-powered meters. The circuit of Figure 2 avoids problems normally associated with ground loop currents. Separate ground runs should be used for 5V RETURN (pin 3) and (–) INPUT LO (pin 12).

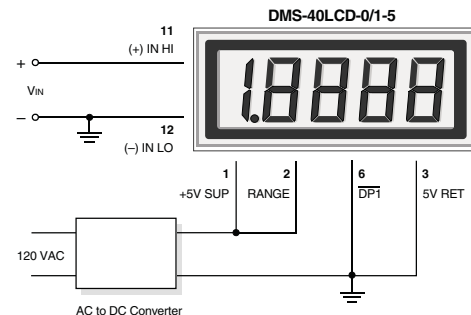

**Figure 2. Single-Ended Input Configuration (5V-Powered Models)**

**APPLICATIONS**

**2. Differential Input Configurations:** Differential measurements can be made with either 5V-powered or 9V-powered meters. Figure 3, though not a practical real-world application, uses a voltage divider to demonstrate the concept of a differential input signal. Be careful not to exceed the ±2V common mode voltage limitation for 5V-powered meters.

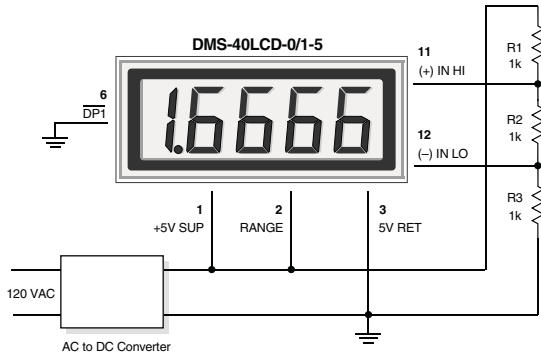
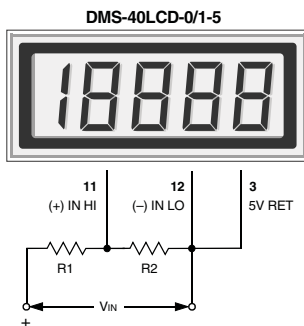

**Figure 3. Differential Input Configuration (5V-Powered Models)**

**3. Engineering Scaling:** For measuring voltages greater than the full scale input range of a given meter, the input signal must be attenuated. A simple voltage divider (similar to that shown in Figure 4) will scale the input to within the range of the selected meter. R1 and R2 should be precision, ±1%, metal film resistors with absolute TCR's less than 50ppm/°C. See Ap Note 4 for more information on engineering scaling.

$$50k\Omega < R1 + R2 < 10M\Omega$$

$$\frac{R2}{R1 + R2} \times V_{IN} = \text{Reading}$$



**Figure 4. Input Attenuation Circuit**

**4. Floating Signal Source Measurements:** Floating signals can be measured using the circuits shown in Figures 5 and 6. Figure 5 uses a 5V-powered meter. Figure 6 uses a 9V-powered meter. Both figures show a DMS-40LCD-0/1 with pin 2 tied to pin 1 yielding a ±2V input range. Connecting pin 10 (ANALOG COMMON) to (-) INPUT LO (pin 12) provides the reference point for the meter's input.

A “floating” input is a signal that has no galvanic connection to the meter’s power supply. In the figures below, the 1.5V battery illustrates a true floating input.

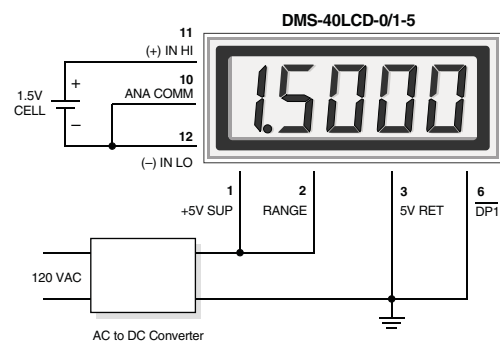

**Figure 5. Floating Input Measurements (5V-Powered Models)**

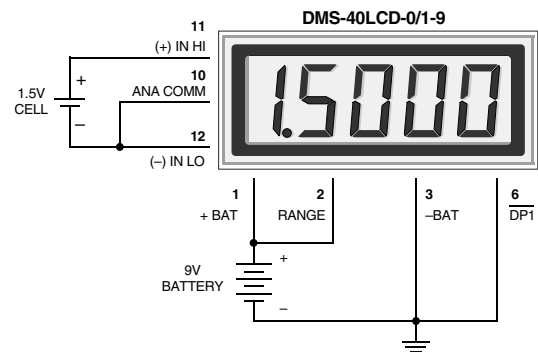

**Figure 6. Floating Input Measurements (9V-Powered Models)**

**APPLICATIONS**

**5. Process Control (4-to-20mA) Measurements:** In many common process-control applications, a 4-to-20mA current loop is used to transmit information. Because DMS-40LCD meters have such high input impedance, a simple shunt resistor across the meter's input can be used to convert the loop current to a voltage. See Figure 7. The value of the shunt resistor is a function of the scaling requirements of the particular application and can be calculated using the following equation:

$$R_{Shunt} = R1 = V_{Fsr} / I_{Fsr}$$

Where:  $V_{Fsr}$  = Full scale reading (in Volts)

$I_{Fsr}$  = Relative full scale current (in Amps)

Example: For a meter with a 2V full scale input (1.999 full scale reading) and a desired full scale display reading of 1000 (with an input of 20mA),  $V_{Fsr} = 1.000$  Volts

$$R_{Shunt} = 1.000V / (0.020 - 0.004)A$$

$$R_{Shunt} = 1.000V / 0.016A = 62.5 \text{ Ohms}$$

To calibrate the circuit of Figure 7, perform the following:

1. With 4mA applied, adjust the 50kΩ potentiometer (R2) to display a reading of "0000" (assuming that is the desired reading).
2. With 20mA applied, adjust the gain-adjust potentiometer on the back of the meter to display a reading of "19999". For different full scale readings, alter the value of  $R_{Shunt}$  accordingly.

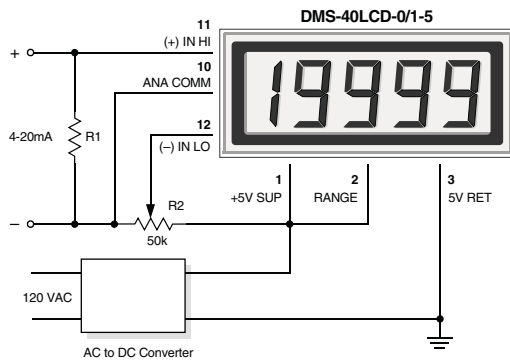

**Figure 7. 4-to-20mA Current Loop Operation (5V-Powered Models)**

**6. Power Supply Monitoring:** A popular application for DATEL's low-power LCD meters is monitoring the supply voltage in battery-operated portable equipment. Figure 8 demonstrates how a 9V-powered DMS-40LCD can be used to monitor its own supply. The meter used is the DMS-40LCD-0/1-9 configured for its ±2V input range (pin 2 connected to pin 1). A three-resistor voltage divider is used to attenuate the battery voltage and also to satisfy the requirement that the input voltages applied to pins 12 and 11 be at least 1.5 Volts above and below the battery voltage applied to pins 1 (+BATTERY) and 3 (-BATTERY). The divider should be designed so that 1/10th the battery voltage falls across the inputs to the meter.

$$\frac{R2}{(R1 + R2 + R3)} = 0.1$$

Therefore, the 9V battery voltage appears to the meter inputs as 0.9V. With the decimal point moved to its DP2 position (pin 5 tied to pin 3), the meter reads 9.000 Volts.

The circuit can be calibrated by first measuring the actual battery voltage with another meter and then adjusting the gain-adjust potentiometer on the back of the DMS-40LCD until a similar reading is obtained. If possible, the resistors in the divider should be ±1% metal-film types with TCR's less than 50ppm/°C.

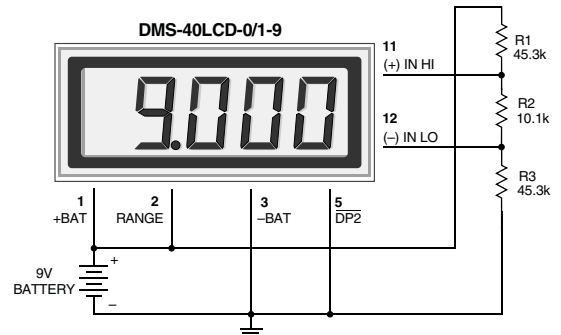

**Figure 8. Power Supply Monitor (9V-Powered Models)**

## MECHANICAL SPECIFICATIONS

MECHANICAL DIMENSIONS: Inches (mm)

TOLERANCES: 2 PL DEC ±0.02 (±0.51)

3 PL DEC ±0.010 (±0.254)

LEAD DIMENSIONS: 0.025 (0.635) x 0.025 (0.635) NOMINAL

RECOMMENDED PC BOARD FINISHED HOLE DIAMETER:

0.042 ±0.003 (1.067 ±0.076)

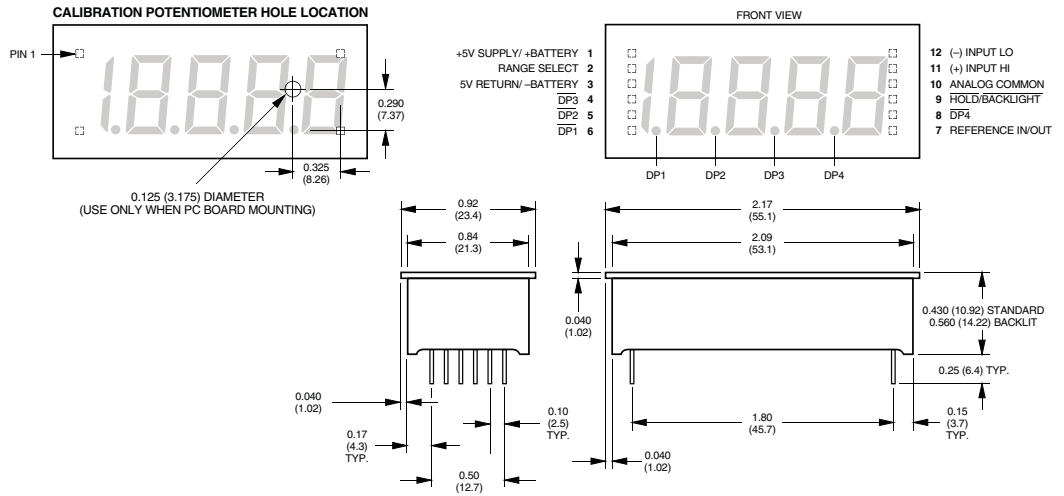

## BEZEL INSTALLATION AND RECOMMENDED DRILL AND PANEL CUTOUT

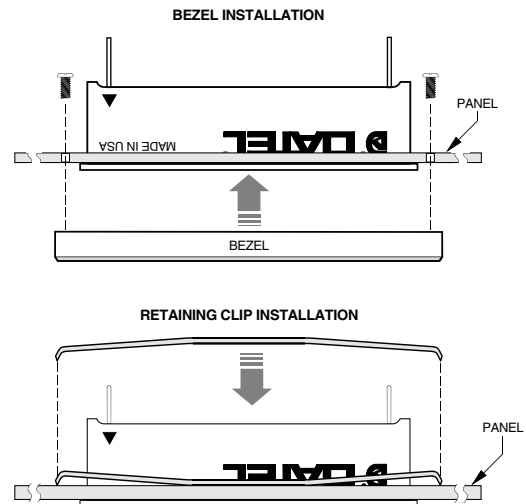
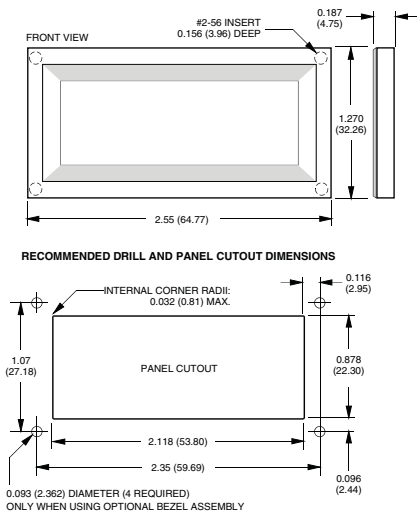

Murata Power Solutions, Inc.  
11 Cabot Boulevard, Mansfield, MA 02048-1151 U.S.A.  
ISO 9001 and 14001 REGISTERED

Murata Power Solutions, Inc. makes no representation that the use of its products in the circuits described herein, or the use of other technical information contained herein, will not infringe upon existing or future patent rights. The descriptions contained herein do not imply the granting of licenses to make, use, or sell equipment constructed in accordance therewith. Specifications are subject to change without notice.  
© 2011 Murata Power Solutions, Inc.

Компания «Океан Электроники» предлагает заключение долгосрочных отношений при поставках импортных электронных компонентов на взаимовыгодных условиях!

Наши преимущества:

- Поставка оригинальных импортных электронных компонентов напрямую с производств Америки, Европы и Азии, а так же с крупнейших складов мира;
- Широкая линейка поставок активных и пассивных импортных электронных компонентов (более 30 млн. наименований);
- Поставка сложных, дефицитных, либо снятых с производства позиций;
- Оперативные сроки поставки под заказ (от 5 рабочих дней);
- Экспресс доставка в любую точку России;
- Помощь Конструкторского Отдела и консультации квалифицированных инженеров;
- Техническая поддержка проекта, помощь в подборе аналогов, поставка прототипов;
- Поставка электронных компонентов под контролем ВП;
- Система менеджмента качества сертифицирована по Международному стандарту ISO 9001;
- При необходимости вся продукция военного и аэрокосмического назначения проходит испытания и сертификацию в лаборатории (по согласованию с заказчиком);
- Поставка специализированных компонентов военного и аэрокосмического уровня качества (Xilinx, Altera, Analog Devices, Intersil, Interpoint, Microsemi, Actel, Aeroflex, Peregrine, VPT, Syfer, Eurofarad, Texas Instruments, MS Kennedy, Miteq, Cobham, E2V, MA-COM, Hittite, Mini-Circuits, General Dynamics и др.);

Компания «Океан Электроники» является официальным дистрибьютором и эксклюзивным представителем в России одного из крупнейших производителей разъемов военного и аэрокосмического назначения «JONHON», а так же официальным дистрибьютором и эксклюзивным представителем в России производителя высокотехнологичных и надежных решений для передачи СВЧ сигналов «FORSTAR».



## JONHON

«JONHON» (основан в 1970 г.)

Разъемы специального, военного и аэрокосмического назначения:

(Применяются в военной, авиационной, аэрокосмической, морской, железнодорожной, горно- и нефтедобывающей отраслях промышленности)

«FORSTAR» (основан в 1998 г.)

ВЧ соединители, коаксиальные кабели,  
кабельные сборки и микроволновые компоненты:

(Применяются в телекоммуникациях гражданского и специального назначения, в средствах связи, РЛС, а так же военной, авиационной и аэрокосмической отраслях промышленности).



Телефон: 8 (812) 309-75-97 (многоканальный)

Факс: 8 (812) 320-03-32

Электронная почта: [ocean@oceanchips.ru](mailto:ocean@oceanchips.ru)

Web: <http://oceanchips.ru/>

Адрес: 198099, г. Санкт-Петербург, ул. Калинина, д. 2, корп. 4, лит. А