

## DC-EC Series – General purpose DC LVDT



- High level  $\pm 10$ VDC output
- Stroke ranges from  $\pm 0.05$  to  $\pm 10$ in
- 0.25% linearity
- Reverse polarity protection
- Double magnetic shielding
- Stainless steel housing
- Imperial or metric threaded core

### DESCRIPTION

The **DC-EC Series** DC operated LVDTs combine a computer-designed AC LVDT with custom integral signal conditioning to achieve premium performance. Operating on a nominal  $\pm 15$ VDC supply, the DC-EC Series delivers an extremely linear, low noise, yet high frequency response  $\pm 10$ VDC output.

Innovative design and manufacturing techniques further enhance the DC-EC performance and cost efficiency. The micro-miniature components employed were meticulously selected for maximum stability and thermal performance. Vacuum encapsulation of all elements affords excellent shock and vibration tolerance, while double magnetic shielding provides the utmost protection from stray fields.

Like in most of our LVDTs, the DC-EC windings are vacuum impregnated with a specially formulated, high temperature, flexible resin, and the coil assembly is potted inside its housing with a two-component epoxy. This provides excellent protection against hostile environments such as high humidity, vibration and shock.

Available in a variety of stroke ranges from  $\pm 0.05$  to  $\pm 10$  inches, the DC-EC Series can be configured with a number of standard options including metric threaded core, guided core and small diameter/low mass core.

Captive core option: The DC-EC features an optional captive core design (available for most models) that greatly simplifies installation. The core rod and bearing assembly includes a Bronze bearing on the front end for self-alignment, while a PTFE sleeve allows low-friction travel through the stainless steel boreliner (spool tube). The core rod and the bearing assembly are both field serviceable.

Also see our other LVDTs with built-in signal conditioning: **DC-SE** (single-ended DC voltage), **HCD** (Hermetically sealed,  $\pm$ DC voltage), **HC-485** (RS485 digital output), and the **HCT** (4-20mA, 2-wire loop).

Measurement Specialties, Inc. (NASDAQ MEAS) offers many other types of sensors and signal conditioners. Data sheets can be downloaded from our web site at: <http://www.meas-spec.com/datasheets.aspx>

MEAS acquired Schaevitz Sensors and the **Schaevitz™** trademark in 2000.

### FEATURES

- Bi-polar DC operation
- Shock and vibration tolerant
- Captive core option (*available on select models*)
- AISI 400 Series stainless steel housing
- CE compliant
- Calibration certificate supplied with each unit

### APPLICATIONS

- Materials testing
- Z-axis position feedback for punch-presses
- Microscope X-Y stage position control
- Medical imaging
- Automotive suspension testing
- Flight simulators

# DC-EC Series – General purpose DC LVDT

## PERFORMANCE SPECIFICATIONS

ELECTRICAL SPECIFICATIONS									
Parameter	DC-EC 050	DC-EC 125	DC-EC 250	DC-EC 500	DC-EC 1000	DC-EC 2000	DC-EC 3000	DC-EC 5000	DC-EC 10000
Stroke range	±0.050 [±1.27]	±0.125 [±3.17]	±0.25 [±6.35]	±0.5 [±12.7]	±1 [±25.4]	±2 [±50.8]	±3 [±76.2]	±5 [±127]	±10 [±254]
Sensitivity, VDC/inch	200	80	40	20	10	5	3.3	2.0	1.0
Sensitivity, VDC/mm	7.9	3.15	1.6	0.79	0.39	0.20	0.13	0.079	0.039
Frequency response Hertz @ -3dB	500	500	500	200	200	200	200	200	200
Input voltage	±15VDC								
Input current	±25mA								
Output at stroke ends	±10VDC (Positive and increasing when the core is displaced from null position towards the cable)								
Non-linearity	±0.25% of FR, maximum								
Output ripple	25mVRMS, maximum								
Stability	0.125% of FSO								
Output impedance	1 Ohm								

ENVIRONMENTAL SPECIFICATIONS & MATERIALS	
Operating temperature	+32°F to +160°F [0°C to 70°C]
Survival temperature	-65°F to +200°F [-55°C to 95°C]
Shock survival	250 g (11ms half-sine)
Vibration tolerance	10 g up to 2kHz
Housing material	AISI 400 Series stainless steel
Electrical connection	Cable with 4 conductors, 28AWG stranded copper, braided shield and polyurethane jacket, 39 inches [1 meter] long. <b>Shield is connected to case.</b>
IEC 60529 rating	IP61

Notes:

All values are nominal unless otherwise noted

Dimensions are in inch [mm] unless otherwise noted

FR: Full Range is the stroke range, end to end; FR=2xS for ±S stroke range

FSO (Full Scale Output): Largest absolute value of the outputs measured at the ends of the range

## WIRING INFORMATION

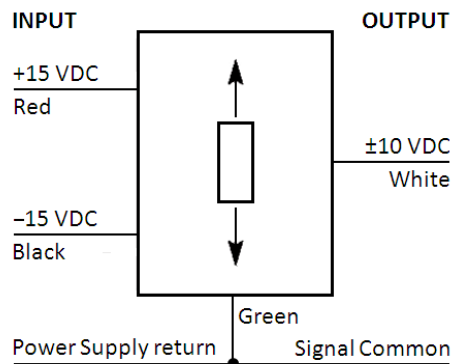

# DC-EC Series – General purpose DC LVDT

## MECHANICAL SPECIFICATIONS – NON-CAPTIVE CORE (STANDARD)

Parameter	DC-EC 050	DC-EC 125	DC-EC 250	DC-EC 500	DC-EC 1000	DC-EC 2000	DC-EC 3000	DC-EC 5000	DC-EC 10000
Main body length "A"	2.10 [53.3]	2.93 [74.4]	3.80 [96.5]	5.49 [139.4]	7.75 [196.9]	11.12 [282.4]	16.32 [414.5]	20.15 [511.8]	35.38 [898.7]
Core length "B"	0.75 [19.1]	1.25 [31.8]	2.00 [50.8]	3.00 [76.2]	3.80 [96.5]	5.30 [134.6]	6.20 [157.5]	6.20 [157.5]	12.00 [304.8]
Core center at null "P"	0.50 [12.7]	0.93 [23.6]	1.35 [34.3]	2.20 [55.9]	3.18 [80.8]	5.3 [134.6]	7.55 [191.8]	9.53 [242.1]	16.58 [421.1]
Body weight oz [gram]	2.19 [62]	2.44 [69]	2.58 [73]	2.93 [83]	4.24 [120]	5.47 [155]	9.39 [266]	11.47 [325]	15.71 [445]
Core weight oz [gram]	0.07 [2]	0.11 [3]	0.18 [5]	0.28 [8]	0.35 [10]	0.46 [13]	0.49 [14]	0.60 [17]	0.85 [24]

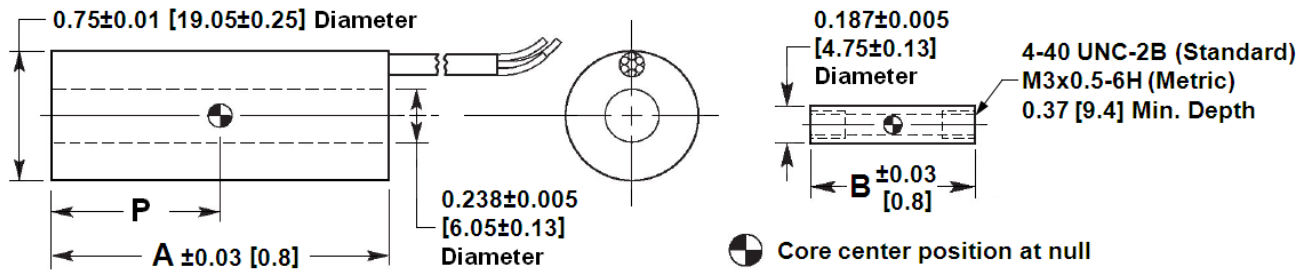

Dimensions are in inch [mm]

## MECHANICAL SPECIFICATIONS – CAPTIVE CORE OPTION

Parameter	DC-EC 050	DC-EC 125	DC-EC 250	DC-EC 500	DC-EC 1000	DC-EC 2000	DC-EC 3000
Main body length "A"	2.48 [63.0]	3.31 [84.1]	4.18 [106.7]	5.87 [149.1]	8.13 [206.5]	11.50 [292.1]	16.70 [424.2]
Core rod position at null "R"	3.78 [96.0]	4.36 [110.7]	4.85 [123.2]	6.04 [153.4]	7.90 [200.7]	10.52 [267.2]	15.27 [387.9]
Center of core position at null "P"	0.84 [21.3]	1.27 [32.3]	1.69 [42.9]	2.54 [64.5]	3.52 [89.4]	5.22 [132.6]	7.89 [200.4]
Weight oz [gram]	2.97 [84]	3.32 [94]	3.53 [100]	4.02 [114]	5.61 [159]	7.2 [204]	11.68 [331]

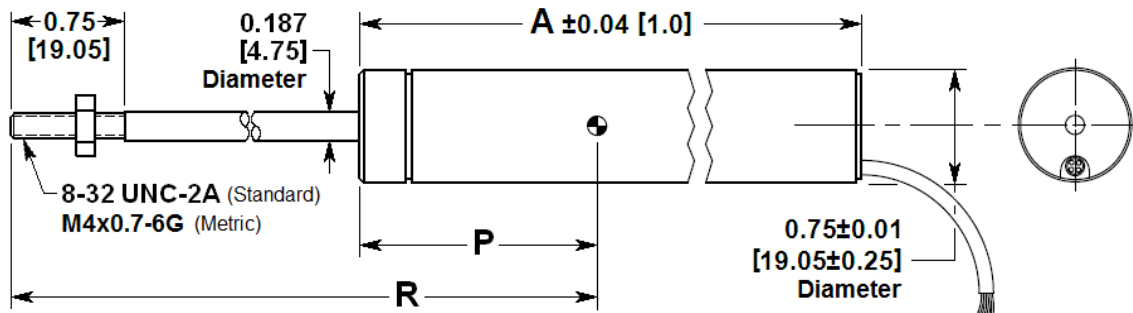

Dimensions are in inch [mm]

# DC-EC Series – General purpose DC LVDT

## ORDERING INFORMATION

Description	Model	Part Number
±0.050 inch LVDT	DC-EC 050	02560981-000
±0.125 inch LVDT	DC-EC 125	02560982-000
±0.25 inch LVDT	DC-EC 250	02560983-000
±0.5 inch LVDT	DC-EC 500	02560984-000
±1 inch LVDT	DC-EC 1000	02560985-000

Description	Model	Part Number
±2 inch LVDT	DC-EC 2000	02560986-000
±3 inch LVDT	DC-EC 3000	02560987-000
±5 inch LVDT	DC-EC 5000	02560988-000
±10 inch LVDT	DC-EC 10000	02560989-000

OPTIONS		
Metric threaded core (M3 x 0.5-6H)	ALL DC-EC	XXXXXXXX-006
Guided core	ALL DC-EC	XXXXXXXX-010
Small-diameter/low-mass core ( <i>consult factory for mass &amp; dimensions</i> )	ALL DC-EC	XXXXXXXX-020
Captive core	DC-EC 050 thru 3000 only	XXXXXXXX-200

**Note:** Add multiple option dash numbers together to determine proper ordering suffix

Example: DC-EC 1000, ±1 inch, with metric threaded and guided core, P/N 02560985-016

ACCESSORIES		
Dual rail DC power supply (±15VDC)	Model PSD 40-15	02291339-000
Core connecting rod, 6 inches long, 4-40 threads		05282946-006
Core connecting rod, 12 inches long, 4-40 threads		05282946-012
Core connecting rod, 24 inches long, 4-40 threads		05282946-024
Core connecting rod, 36 inches long, 4-40 threads		05282946-036
Core connecting rod, 6 inches long, M3x0.5 metric threads		05282977-006
Core connecting rod, 12 inches long, M3x0.5 metric threads		05282977-012
Mounting block		04560950-000

Refer to our "[Accessories for LVDTs](#)" data sheet for our LVDT signal conditioning instrumentation and other accessories.

## TECHNICAL CONTACT INFORMATION

NORTH AMERICA	EUROPE	ASIA
Measurement Specialties, Inc. 1000 Lucas Way Hampton, VA 23666 United States Phone: +1-800-745-8008 Fax: +1-757-766-4297 Email: <a href="mailto:sales@meas-spec.com">sales@meas-spec.com</a> Web: <a href="http://www.meas-spec.com">www.meas-spec.com</a>	MEAS Deutschland GmbH Hauert 13 D-44227 Dortmund Germany Phone: +49-(0)231-9740-0 Fax: +49-(0)231-9740-20 Email: <a href="mailto:info.de@meas-spec.com">info.de@meas-spec.com</a> Web: <a href="http://www.meas-spec.com">www.meas-spec.com</a>	Measurement Specialties China Ltd. No. 26, Langshan Road High-tech Park (North) Nanshan District, Shenzhen 518057 China Phone: +86-755-33305088 Fax: +86-755-33305099 Email: <a href="mailto:info.cn@meas-spec.com">info.cn@meas-spec.com</a> Web: <a href="http://www.meas-spec.com">www.meas-spec.com</a>

The information in this sheet has been carefully reviewed and is believed to be accurate; however, no responsibility is assumed for inaccuracies. Furthermore, this information does not convey to the purchaser of such devices any license under the patent rights to the manufacturer. Measurement Specialties, Inc. reserves the right to make changes without further notice to any product herein. Measurement Specialties, Inc. makes no warranty, representation or guarantee regarding the suitability of its product for any particular purpose, nor does Measurement Specialties, Inc. assume any liability arising out of the application or use of any product or circuit and specifically disclaims any and all liability, including without limitation consequential or incidental damages. Typical parameters can and do vary in different applications. All operating parameters must be validated for each customer application by customer's technical experts. Measurement Specialties, Inc. does not convey any license under its patent rights nor the rights of others.

Компания «Океан Электроники» предлагает заключение долгосрочных отношений при поставках импортных электронных компонентов на взаимовыгодных условиях!

Наши преимущества:

- Поставка оригинальных импортных электронных компонентов напрямую с производств Америки, Европы и Азии, а так же с крупнейших складов мира;
- Широкая линейка поставок активных и пассивных импортных электронных компонентов (более 30 млн. наименований);
- Поставка сложных, дефицитных, либо снятых с производства позиций;
- Оперативные сроки поставки под заказ (от 5 рабочих дней);
- Экспресс доставка в любую точку России;
- Помощь Конструкторского Отдела и консультации квалифицированных инженеров;
- Техническая поддержка проекта, помощь в подборе аналогов, поставка прототипов;
- Поставка электронных компонентов под контролем ВП;
- Система менеджмента качества сертифицирована по Международному стандарту ISO 9001;
- При необходимости вся продукция военного и аэрокосмического назначения проходит испытания и сертификацию в лаборатории (по согласованию с заказчиком);
- Поставка специализированных компонентов военного и аэрокосмического уровня качества (Xilinx, Altera, Analog Devices, Intersil, Interpoint, Microsemi, Actel, Aeroflex, Peregrine, VPT, Syfer, Eurofarad, Texas Instruments, MS Kennedy, Miteq, Cobham, E2V, MA-COM, Hittite, Mini-Circuits, General Dynamics и др.);

Компания «Океан Электроники» является официальным дистрибьютором и эксклюзивным представителем в России одного из крупнейших производителей разъемов военного и аэрокосмического назначения «JONHON», а так же официальным дистрибьютором и эксклюзивным представителем в России производителя высокотехнологичных и надежных решений для передачи СВЧ сигналов «FORSTAR».



## JONHON

«JONHON» (основан в 1970 г.)

Разъемы специального, военного и аэрокосмического назначения:

(Применяются в военной, авиационной, аэрокосмической, морской, железнодорожной, горно- и нефтедобывающей отраслях промышленности)

«FORSTAR» (основан в 1998 г.)

ВЧ соединители, коаксиальные кабели, кабельные сборки и микроволновые компоненты:

(Применяются в телекоммуникациях гражданского и специального назначения, в средствах связи, РЛС, а так же военной, авиационной и аэрокосмической отраслях промышленности).



Телефон: 8 (812) 309-75-97 (многоканальный)

Факс: 8 (812) 320-03-32

Электронная почта: [ocean@oceanchips.ru](mailto:ocean@oceanchips.ru)

Web: <http://oceanchips.ru/>

Адрес: 198099, г. Санкт-Петербург, ул. Калинина, д. 2, корп. 4, лит. А