

# CRYSTAL-LESS PCI EXPRESS DUAL OUTPUT ULTRA MINIATURE PURE SILICON™ SMD CLOCK GENERATOR

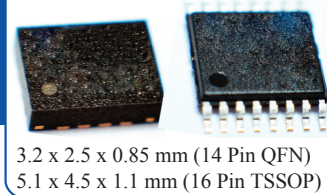

AB-557-03 Series

Moisture Sensitivity Level  
MSL 1 – 14 QFN  
MSL 3 – 16 TSSOP



RoHS/RoHS II compliant

## FEATURES:

- Meets PCIe Gen1, Gen2, & Gen3 specs.
- High Performance MEMS Technology by Discera
- Available Mixed Output Formats: HCSL, LVPECL, LVDS or LVCMOS
- Wide Temperature Range: -40° to 105° C
- Wide Supply Range: 2.25V to 3.6 V
- Low Power Consumption
- Excellent Shock & Vibration Immunity

## APPLICATIONS:

- Solid State Storage
- Storage Area Networks
- Passive Optical Networks
- Ethernet: 1G, 10GBASE-T/KR/LR/SR, and FCoE
- TV and other Consumer Electronics
- Industrial and Medical
- Scanner, Printer

## STANDARD SPECIFICATIONS:

Parameters		Minimum	Typical	Maximum	Units	Notes
Frequency	$f_0$	2.3	100	460 <sup>*1</sup>	MHz	
Operating Temperature		-20		+70	°C	See options
Storage Temperature		-55		+150	°C	
Overall Freq. Stability <sup>*2</sup>	$\Delta f$	-100		+100	ppm	See options
Supply Voltage	$V_{DD}$	+2.25		+3.6	V	
Supply Current- Enabled	$I_{DD}$		60		mA	$R_L=50\Omega$ , $F_{01}=F_{02}=100.00\text{MHz}$
Supply Current- Disabled	$I_{DD}$		21	23	mA	
Startup Time	$t_{su}$			5	ms	
Enable Time	$t_{EN}$			20	ns	
Disable Time	$t_{DA}$			5	ns	
Tri-state Function (Standby/Disable)		"1" ( $V_{IH} \geq 0.75 * V_{DD}$ ) or Open: Oscillation "0" ( $V_{IL} < 0.25 * V_{DD}$ ) : Hi Z			V	40k $\Omega$ pull-up resistor embedded
Aging		-5.0		+5.0	ppm	First year
Output Offset Voltage	$V_{OH}$	0.725			V	$R_L=50 \Omega$
	$V_{OL}$			0.10		
Peak to Peak Output Swing			750		mV	Single-Ended
Rise Time	$t_r$	200		400	ps	$R_L=50 \Omega$ , $C_L=2\text{pF}$
Fall Time	$t_f$	200		400	ps	20% to 80%
Duty Cycle	SYM	48		52	%	Differential
Period Jitter	$J_{PER}$		2.5		pSRMS	$F_{01}=F_{02}=100.00\text{MHz}$
Integrated Phase Noise (Common Clock Architecture)	$R_J$		0.540		pSRMS	PCIe Gen 1.1 $T_J = D_J + 14.069 \times R_J$ (BER 10-12)
	$D_J$		0.832	41.9	pSP-P	
	$T_J$		8.536	86.0		
	$J_{RMS-CCHF}$		0.458	3.1	pSRMS	PCIe Gen 2.1 1.5 MHz to Nyquist
	$J_{RMS-CCLF}$		0.030	3.0		PCIe Gen 2.1 10kHz to 1.5 MHz
	$J_{RMS-CC}$		0.165	1.0		PCIe Gen 3.0
Integrated Phase Noise (Data Clock Architecture)	$J_{RMS-DCHF}$		0.561	4.0	pSRMS	PCIe Gen 2.1 1.5 MHz to Nyquist
	$J_{RMS-DCLF}$		1.778	7.5		PCIe Gen 2.1 10kHz to 1.5 MHz
	$J_{RMS-DC}$		0.147	1.0		PCIe Gen 3.0

\*1. For frequency other than 100MHz, please contact ABRACON or consider using ASEMDxx series

2. Frequency stability includes frequency variations due to initial tolerance, temp. and power supply voltage

ABRACON IS  
ISO9001:2008  
CERTIFIED



**ABRACON**  
CORPORATION

Visit [www.abracon.com](http://www.abracon.com) for Terms & Conditions of Sale

Revised: 04.12.13

30332 Esperanza, Rancho Santa Margarita, California 92688

tel 949-546-8000 | fax 949-546-8001 | [www.abracon.com](http://www.abracon.com)

# CRYSTAL-LESS PCI EXPRESS DUAL OUTPUT ULTRA MINIATURE PURE SILICON™ SMD CLOCK GENERATOR

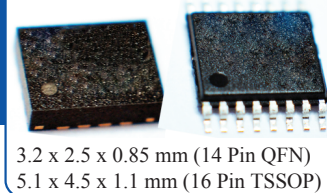

AB-557-03 Series



RoHS/RoHS II compliant

## Absolute Maximum Ratings

Item	Minimum	Maximum	Unit	Condition
Supply Voltage	-0.3	+4.0	V	
Input Voltage	-0.3	V <sub>dd</sub> +0.3	V	
Junction Temp.		+150	°C	
Storage Temp.	-55	+150	°C	
Soldering Temp.		+260	°C	40sec max
ESD				
HBM		4,000	V	
MM		400		
CDM		1,500		

## Block Diagram:

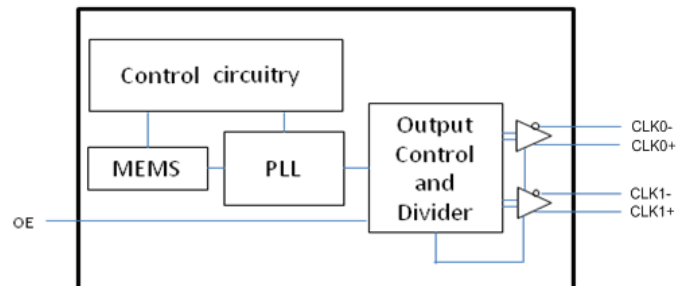

## PIN LAYOUT:

### 14 Pin QFN:

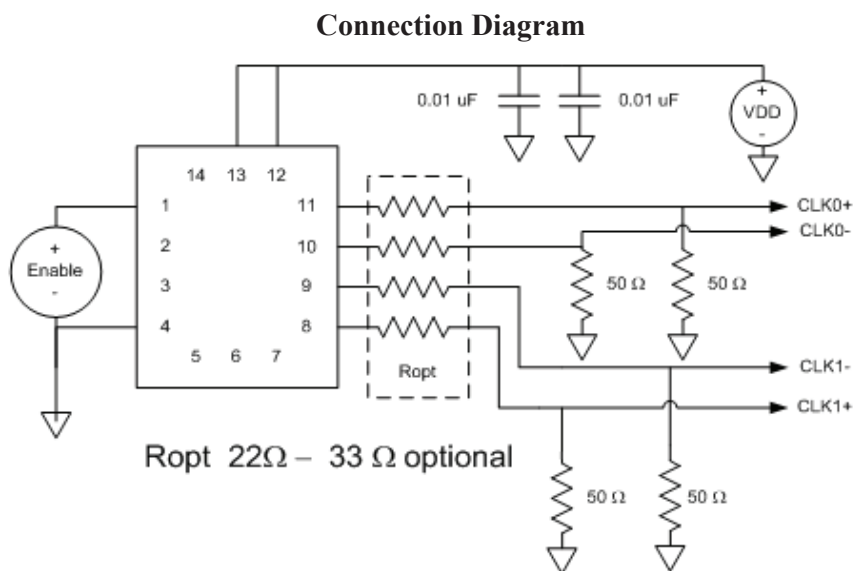
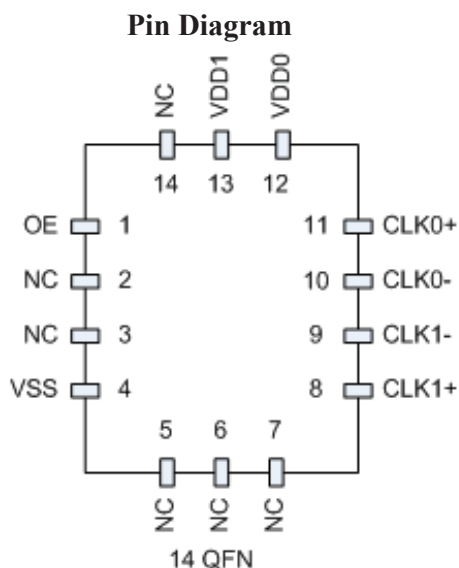

Pin No.	Pin Name	Pin Type	Description
1	OE	I	Output Enable; active high
2	NC	NA	Ground Connected or Leave Unconnected
3	NC	NA	Ground Connected or Leave Unconnected
4	VSS	Power	Ground
5	NC	NA	Ground Connected or Leave Unconnected
6	NC	NA	Ground Connected or Leave Unconnected
7	NC	NA	Ground Connected or Leave Unconnected
8	CLK1+	O	True output of differential pair
9	CLK1-	O	Complement output of differential pair
10	CLK0-	O	Complement output of differential pair
11	CLK0+	O	True output of differential pair
12	VDD0	Power	Power Supply for Output 0 (CLK+/- 0)
13	VDD1	Power	Power Supply for Core and Output 1 (CLK +/- 1)
14	NC	NA	Ground Connected or Leave Unconnected

# CRYSTAL-LESS PCI EXPRESS DUAL OUTPUT ULTRA MINIATURE PURE SILICON™ SMD CLOCK GENERATOR

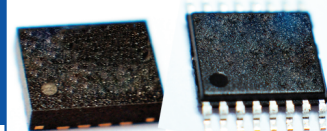

3.2 x 2.5 x 0.85 mm (14 Pin QFN)  
5.1 x 4.5 x 1.1 mm (16 Pin TSSOP)

AB-557-03 Series



RoHS/RoHS II compliant

## 16 Pin TSSOP:

Pin Diagram

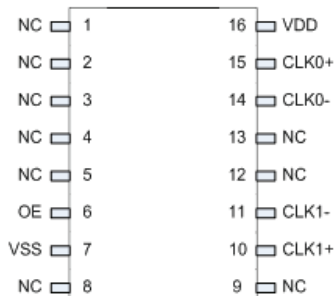

16-pin TSSOP

Connection Diagram

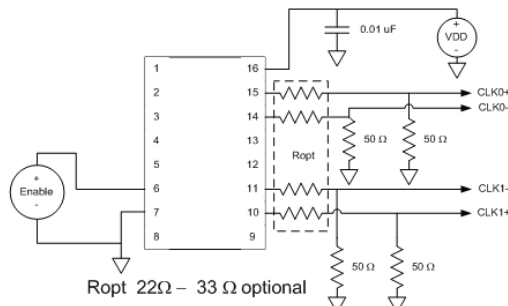

Pin No.	Pin Name	Pin Type	Description
1	NC	NA	Leave Unconnected
2	NC	NA	Leave Unconnected
3	NC	NA	Leave Unconnected
4	NC	NA	Leave Unconnected
5	NC	NA	Leave Unconnected
6	OE	I	Output Enable; active high
7	VSS	Power	Ground
8	NC	NA	Leave Unconnected
9	NC	NA	Leave Unconnected
10	CLK1+	O	True output of differential pair
11	CLK1-	O	Complement output of differential pair
12	NC	NA	Leave Unconnected
13	NC	NA	Leave Unconnected
14	CLK0-	O	Complement output of differential pair
15	CLK0+	O	True output of differential pair
16	VDD	Power	Power Supply

## PART IDENTIFICATION:

AB-557-03-□□ - □ - □ - □ - □

Output Format, Clk1
C: LVCMOS
LP: LVPECL
LV: LVDS
HC: HCSL

Output Format, Clk0
C: LVCMOS
LP: LVPECL
LV: LVDS
HC: HCSL

Package Type
F: 14-QFN
S: 16-TSSOP

Operating Temp.
E: -20°C ~ +70°C
L: -40°C ~ +85°C
X: -40°C ~ +105°C

Overall Freq. Stability
Blank: ±100ppm
C: ±50ppm

Packaging
Blank: Bulk
T: Tape & Reel(1kpcs / reel)
T3: Tape & Reel(3kpcs/reel)

Note: For frequency other than 100MHz, please contact ABRACON or consider using ASEMDxx series

# CRYSTAL-LESS PCI EXPRESS DUAL OUTPUT ULTRA MINIATURE PURE SILICON™ SMD CLOCK GENERATOR

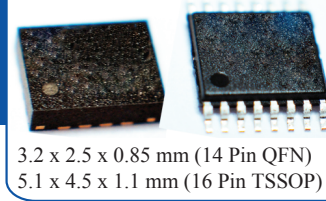

AB-557-03 Series

**Pb** RoHS/RoHS II compliant

3.2 x 2.5 x 0.85 mm (14 Pin QFN)  
5.1 x 4.5 x 1.1 mm (16 Pin TSSOP)

## OUTLINE DRAWING:

### 14 Pin QFN:

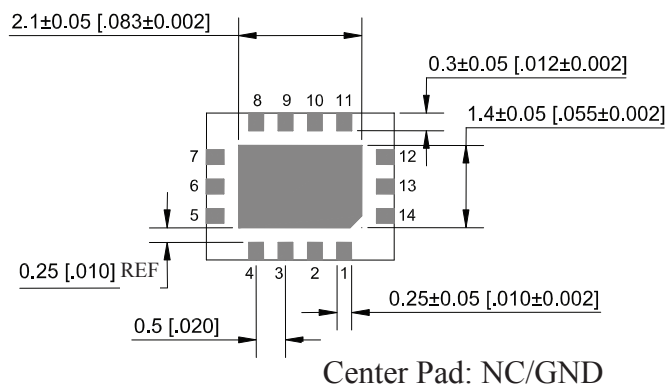
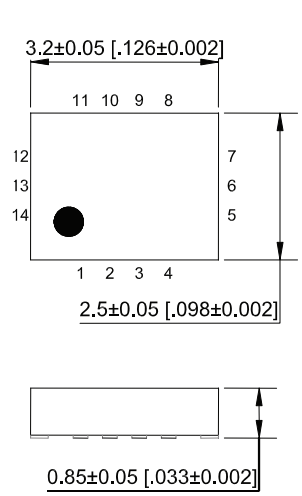

### Recommended Solder Pad Layout

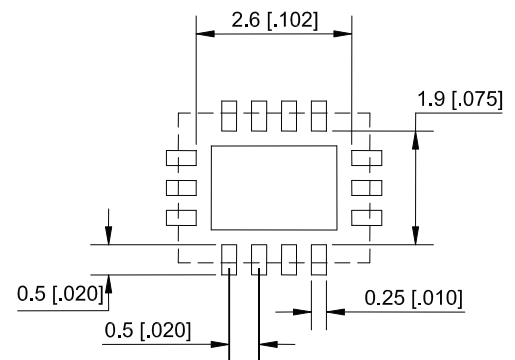

Center Pad: NC/GND

### 16 Pin TSSOP:

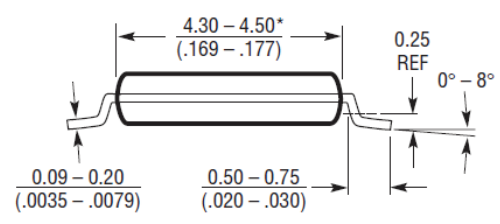
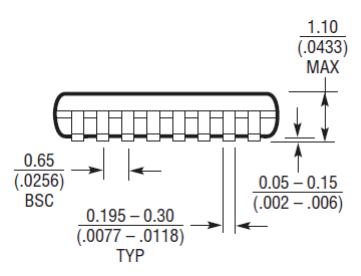

### Recommended Solder Pad Layout

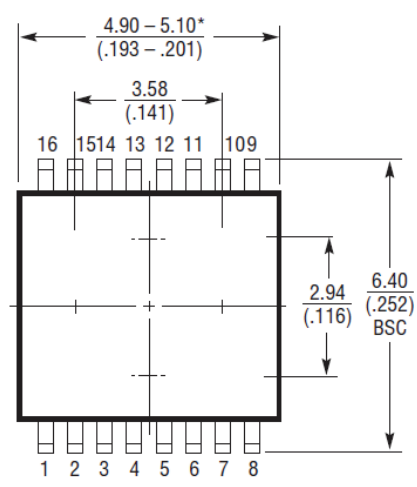
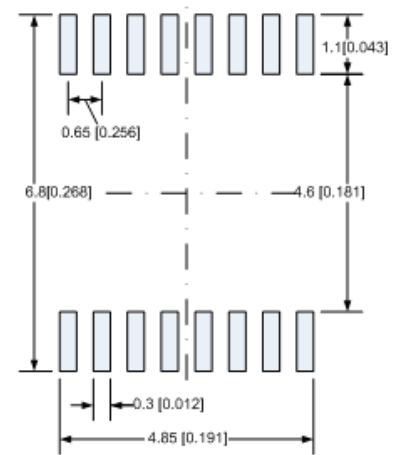

\* Dimensions do not include mold flash. Mold flash shall not exceed 0.150mm (.006 inches) per side.

Dimensions: mm (inches)

ABRACON IS  
ISO9001:2008  
CERTIFIED



Visit [www.abracon.com](http://www.abracon.com) for Terms & Conditions of Sale **Revised: 04.12.13**  
30332 Esperanza, Rancho Santa Margarita, California 92688  
tel 949-546-8000 | fax 949-546-8001 | [www.abracon.com](http://www.abracon.com)

# CRYSTAL-LESS PCI EXPRESS DUAL OUTPUT ULTRA MINIATURE PURE SILICON™ SMD CLOCK GENERATOR

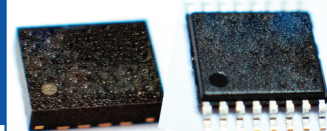

3.2 x 2.5 x 0.85 mm (14 Pin QFN)  
5.1 x 4.5 x 1.1 mm (16 Pin TSSOP)

AB-557-03 Series



RoHS/RoHS II compliant

## REFLOW PROFILE:

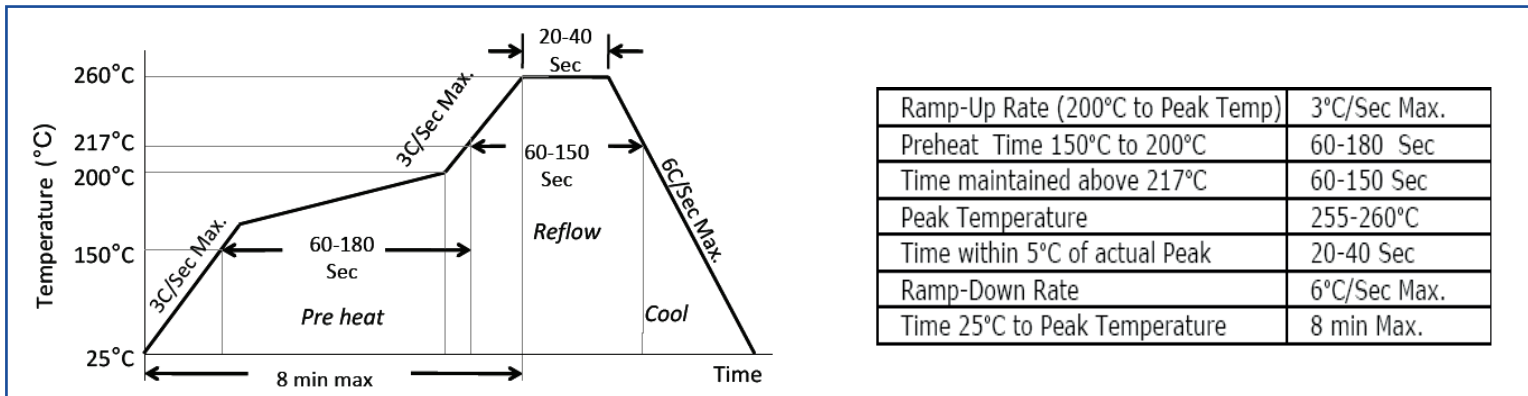

## TAPE & REEL:

### 14 Pin QFN Tape Drawing:

T= 1,000pcs/reel  
T3= 3,000pcs/reel

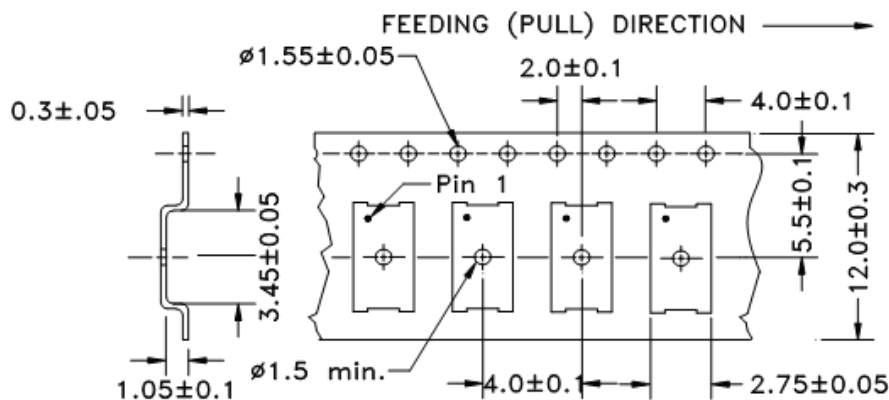

### 16 Pin TSSOP Tape Drawing

T= 1,000pcs/reel  
T3= 3,000pcs/reel

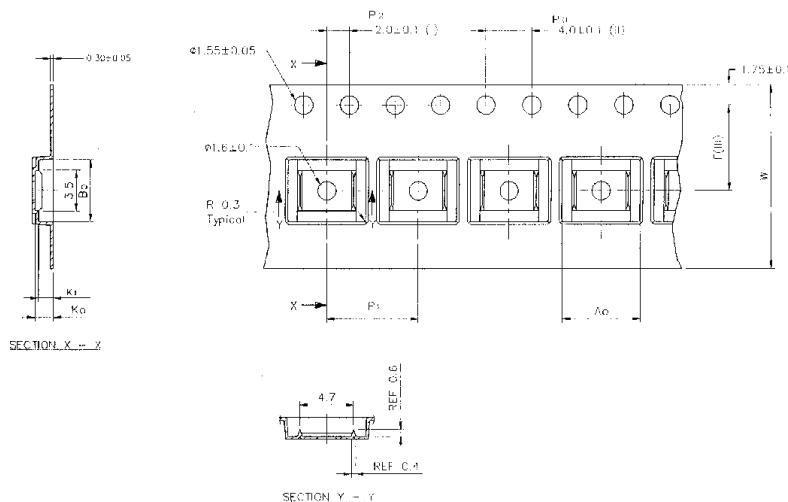

A0	B0	K0	K1	F	P1	W
6.80±0.1	5.40±0.1	1.60±0.1	1.30±0.1	5.50±0.1	8.00±0.1	12.00±0.3

Dimensions: mm

# CRYSTAL-LESS PCI EXPRESS DUAL OUTPUT ULTRA MINIATURE PURE SILICON™ SMD CLOCK GENERATOR

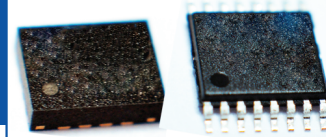

3.2 x 2.5 x 0.85 mm (14 Pin QFN)  
5.1 x 4.5 x 1.1 mm (16 Pin TSSOP)

AB-557-03 Series

**Pb** RoHS/RoHS II compliant

## 7" Reel Drawing (1000pcs/reel)

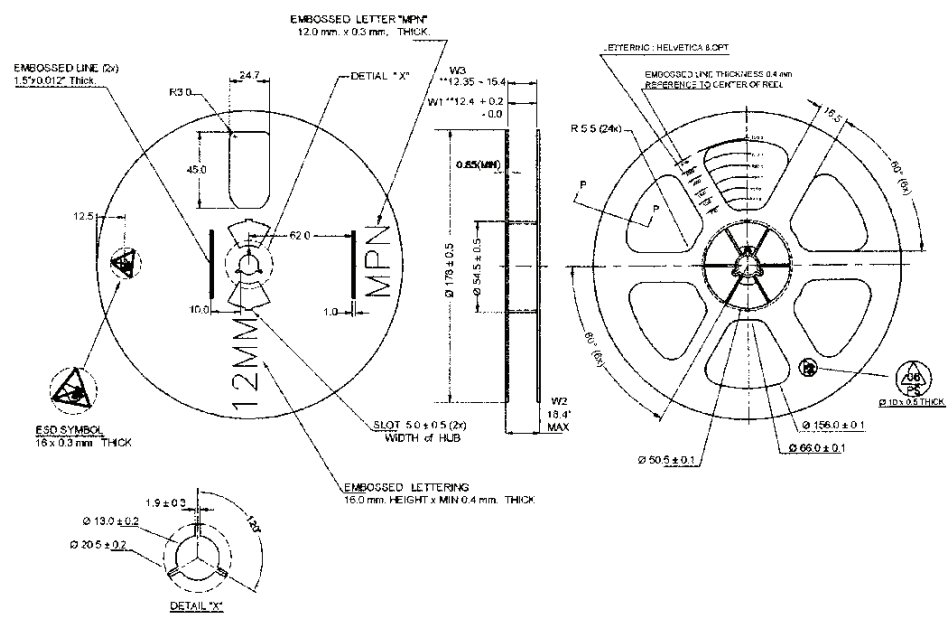

## 13" Reel Drawing (3000pcs/reel)

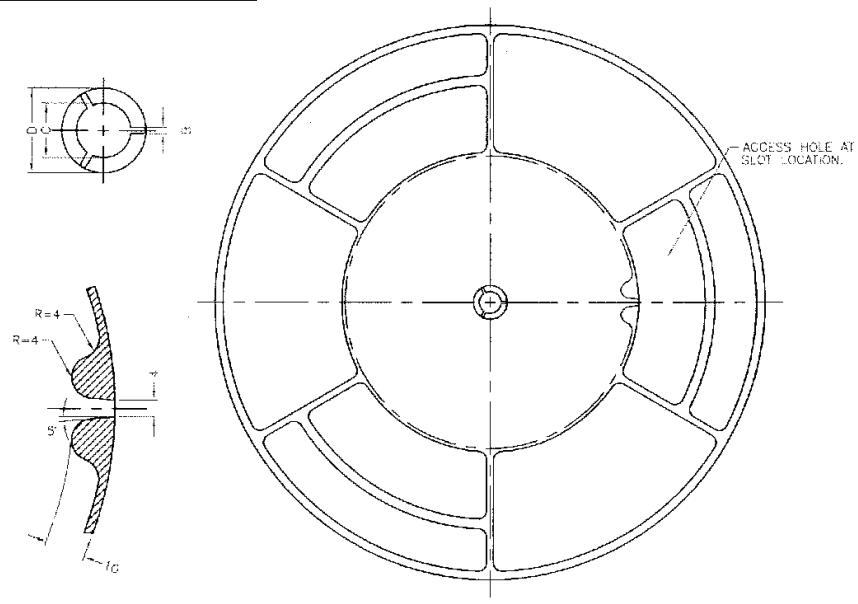

A	N	W1	W2	W3	D	B	C	Tape Width
330 (13")	178 (7") max.	12.4+2/-0	18.4 max.	12.35 min. 15.40 max.	20.2 min.	1.5 min	13.0+0.5/-0.2	12

**ATTENTION:** Abracon Corporation's products are COTS – Commercial-Off-The-Shelf products; suitable for Commercial, Industrial and, where designated, Automotive Applications. Abracon's products are not specifically designed for Military, Aviation, Aerospace, Life-dependant Medical applications or any application requiring high reliability where component failure could result in loss of life and/or property. For applications requiring high reliability and/or presenting an extreme operating environment, written consent and authorization from Abracon Corporation is required. Please contact Abracon Corporation for more information.

ABRACON IS  
ISO9001:2008  
CERTIFIED



Visit [www.abracon.com](http://www.abracon.com) for Terms & Conditions of Sale **Revised: 04.12.13**  
30332 Esperanza, Rancho Santa Margarita, California 92688  
tel 949-546-8000 | fax 949-546-8001 | [www.abracon.com](http://www.abracon.com)



Компания «Океан Электроники» предлагает заключение долгосрочных отношений при поставках импортных электронных компонентов на взаимовыгодных условиях!

Наши преимущества:

- Поставка оригинальных импортных электронных компонентов напрямую с производств Америки, Европы и Азии, а так же с крупнейших складов мира;
- Широкая линейка поставок активных и пассивных импортных электронных компонентов (более 30 млн. наименований);
- Поставка сложных, дефицитных, либо снятых с производства позиций;
- Оперативные сроки поставки под заказ (от 5 рабочих дней);
- Экспресс доставка в любую точку России;
- Помощь Конструкторского Отдела и консультации квалифицированных инженеров;
- Техническая поддержка проекта, помощь в подборе аналогов, поставка прототипов;
- Поставка электронных компонентов под контролем ВП;
- Система менеджмента качества сертифицирована по Международному стандарту ISO 9001;
- При необходимости вся продукция военного и аэрокосмического назначения проходит испытания и сертификацию в лаборатории (по согласованию с заказчиком);
- Поставка специализированных компонентов военного и аэрокосмического уровня качества (Xilinx, Altera, Analog Devices, Intersil, Interpoint, Microsemi, Actel, Aeroflex, Peregrine, VPT, Syfer, Eurofarad, Texas Instruments, MS Kennedy, Miteq, Cobham, E2V, MA-COM, Hittite, Mini-Circuits, General Dynamics и др.);

Компания «Океан Электроники» является официальным дистрибьютором и эксклюзивным представителем в России одного из крупнейших производителей разъемов военного и аэрокосмического назначения «JONHON», а так же официальным дистрибьютором и эксклюзивным представителем в России производителя высокотехнологичных и надежных решений для передачи СВЧ сигналов «FORSTAR».



## JONHON

«JONHON» (основан в 1970 г.)

Разъемы специального, военного и аэрокосмического назначения:

(Применяются в военной, авиационной, аэрокосмической, морской, железнодорожной, горно- и нефтедобывающей отраслях промышленности)

«FORSTAR» (основан в 1998 г.)

ВЧ соединители, коаксиальные кабели, кабельные сборки и микроволновые компоненты:

(Применяются в телекоммуникациях гражданского и специального назначения, в средствах связи, РЛС, а так же военной, авиационной и аэрокосмической отраслях промышленности).



Телефон: 8 (812) 309-75-97 (многоканальный)

Факс: 8 (812) 320-03-32

Электронная почта: [ocean@oceanchips.ru](mailto:ocean@oceanchips.ru)

Web: <http://oceanchips.ru/>

Адрес: 198099, г. Санкт-Петербург, ул. Калинина, д. 2, корп. 4, лит. А