

## PS25101 EPIC sensor, development sensor, high gain Datasheet

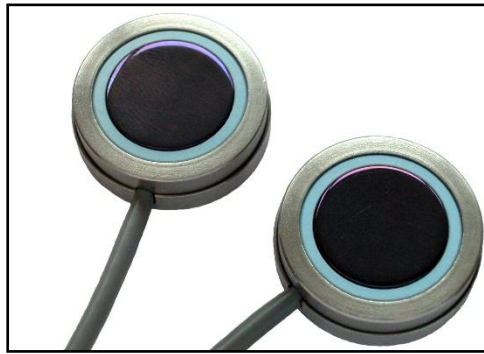

Plessey Semiconductors Electric Potential Integrated Circuit (EPIC) product line targets a range of applications.

The PS25101 is an ultra high impedance solid state ECG (electrocardiograph) sensor. It can be used as a dry contact ECG sensor without the need for potentially dangerous low impedance circuits across the heart. The resolution available is as good as or better than conventional wet electrodes.

The device uses active feedback techniques to both lower the effective input capacitance of the sensing element ( $C_{in}$ ) and boost the input resistance ( $R_{in}$ ). These techniques are used to realise a sensor with a frequency response suitable for both diagnostic and monitoring ECG applications. The total voltage gain of the system is a function of both the input coupling capacitance (variable) and the internal sensor configuration.

### FEATURES

- Ultra high input resistance, typically  $2 \times 10^{10} \Omega$
- Dry-contact capacitive coupling
- Input capacitance as low as 10pF
- Upper -3dB point typically 10kHz
- Lower -3dB point typically 100mHz
- Operates with single +4.75V to 8.0V supply
- Sensors supplied as custom engineered probe assemblies complete with connecting lead and DIN plug termination

## APPLICATIONS

- Non-critical patient monitoring equipment
- Emergency response diagnostics
- Lifestyle sports and health products
- Suitable for long-term and remote monitoring

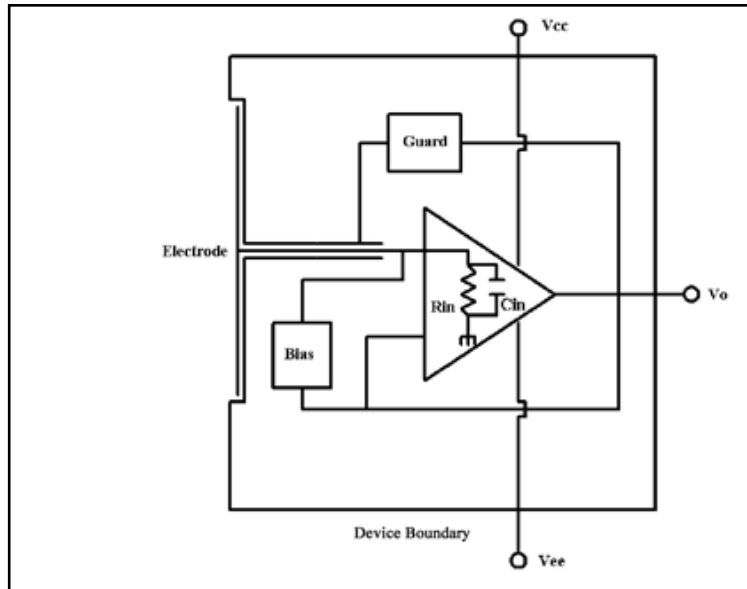

Fig. 1 Internal circuit

## ELECTRICAL CHARACTERISTICS

$T_{amb} = 0^{\circ}\text{C}$  to  $+50^{\circ}\text{C}$ ,  $V_{dd} = +5\text{v}$ . The electrical characteristics are guaranteed by either production test or by design and characterisation. They apply within the specified ambient temperature and supply voltage unless otherwise stated.

Characteristics	Value			Units	Conditions
	Min.	Typ.	Max.		
Supply (Vdd)	+4.75	5.00	8.0		Unipolar ( $V_{ss}=0\text{v}$ ) @ $V_{dd}=5.0\text{V}$ Peak-to-peak  Sensor to skin Set by internal DC signal rejection network – coupling capacitor 1nF
Supply current		4.5		mA	
Voltage Gain ( $A_v$ )		50			
Effective input resistance ( $R_{ine}$ )		20		G $\Omega$	
Effective input capacitance ( $C_{ine}$ )		15		pF	
Coupling capacitance		1		nF	
Lower -3dB point		100		mHz	
Upper -3dB point		10		kHz	
Noise		tbd			
Output voltage swing	-2.4		2.4	V	

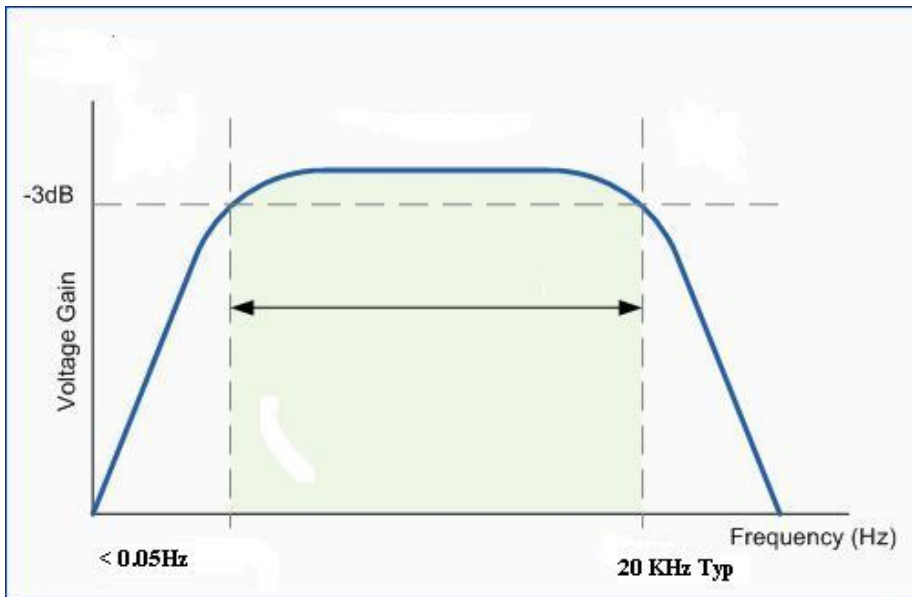

Fig. 2 Typical Bode Plot for EPIC ECG Sensor

#### 4 PIN DIN PLUG TERMINATION



- Pin1 Signal Out (Yellow)
- Pin2 Earth (Green)
- Pin3 +6V (Red)
- Pin4 0V (Blue)

#### APPLICATION OF THE ECG SENSOR

Because of the large coupling capacitance to the body (around 1nF) the EPIC sensor's internal electrometer can be used in differential mode to recover true surface potential ECG signals from the surface of the skin.

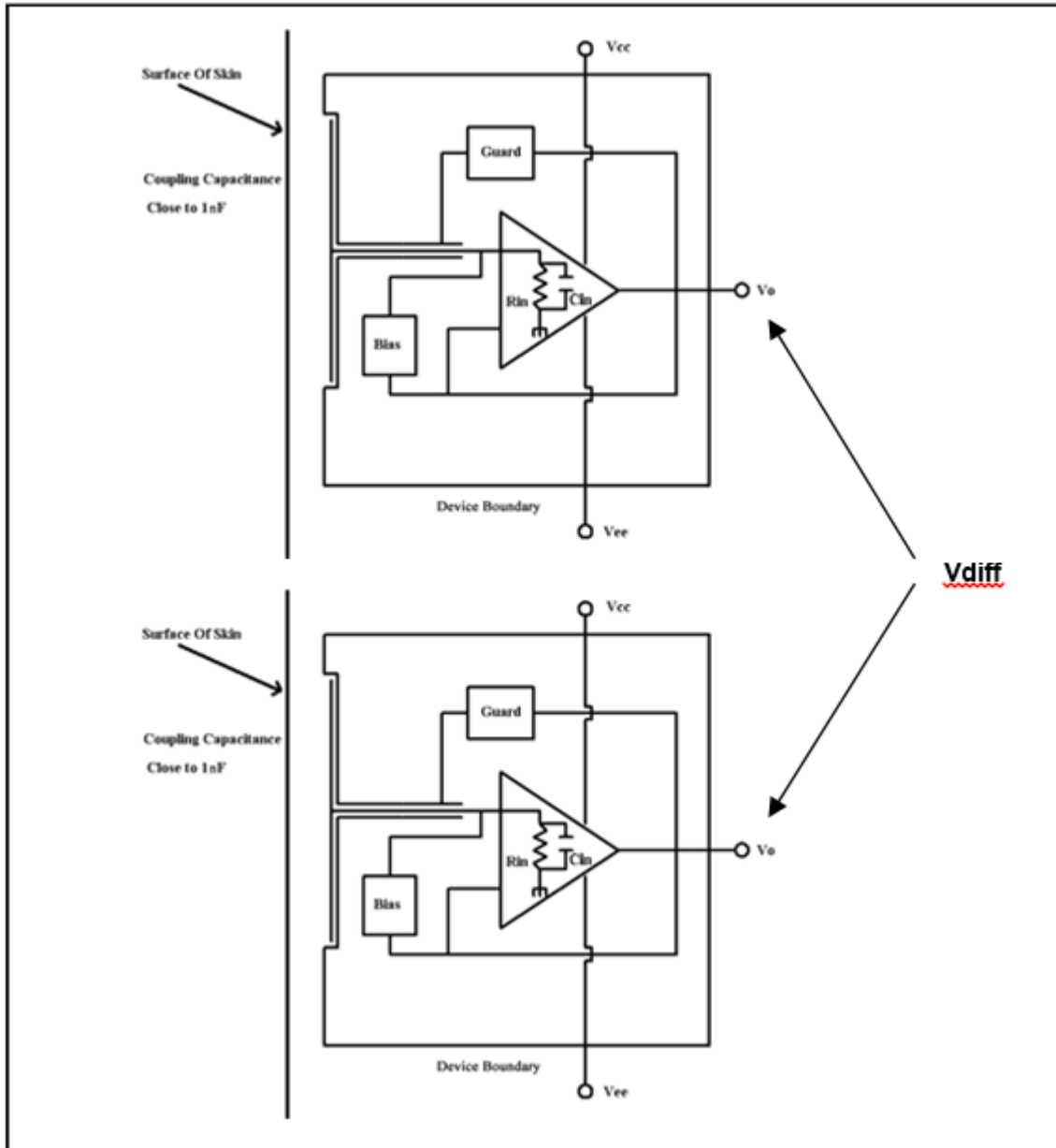

Fig. 3 Differential measurement of body (skin) surface potential to produce ECG trace



Fig. 4 Comparison of two ECG vectors from a pair of EPIC sensors (top) and two conventional Ag/AgCl electrodes (bottom)

## PATENTS

This component and many of the associated applications are covered by the following international patents:

602 32 911.6-08 (DE)	EP2174416
AU2007228660	GB1118970.1
CA2646411	JP2009-500908
CN200780026584.8	JP4391823
EP1451595 (CH)	TW097126903
EP1451595 (ES)	TW1308066
EP1451595 (FR)	US12/293872
EP1451595 (IE)	US12/374359
EP1451595 (IT)	US12/669615
EP1451595 (NL)	US13/020890
EP2002273	US13/163988
EP2047284	US788570

### Customer Enquiries/Sales

+44 1752 693000 | [sales@plesseysemi.com](mailto:sales@plesseysemi.com)

[www.plesseysemi.com](http://www.plesseysemi.com)

Plessey Semiconductors Ltd | Plymouth

Tamerton Road, Roborough

Plymouth, Devon

PL6 7BQ

United Kingdom

P: +44 1752 693000

F: +44 1752 693700

### Legal Notice

Product information provided by Plessey Semiconductors Limited ("Plessey") in this document is believed to be correct and accurate. Plessey reserves the right to change/correct the specifications and other data or information relating to products without notice but Plessey accepts no liability for errors that may appear in this document, howsoever occurring, or liability arising from the use or application of any information or data provided herein. Neither the supply of such information, nor the purchase or use of products conveys any license or permission under patent, copyright, trademark or other intellectual property right of Plessey or third parties.

Products sold by Plessey are subject to its standard Terms and Conditions of Sale that are available on request. No warranty is given that products do not infringe the intellectual property rights of third parties, and furthermore, the use of products in certain ways or in combination with Plessey, or non-Plessey furnished equipments/components may infringe intellectual property rights of Plessey.

The purpose of this document is to provide information only and it may not be used, applied or reproduced (in whole or in part) for any purpose nor be taken as a representation relating to the products in question. No warranty or guarantee express or implied is made concerning the capability, performance or suitability of any product, and information concerning possible applications or methods of use is provided for guidance only and not as a recommendation. The user is solely responsible for determining the performance and suitability of the product in any application and checking that any specification or data it seeks to rely on has not been superseded.

Products are intended for normal commercial applications. For applications requiring unusual environmental requirements, extended temperature range, or high reliability capability (e.g. military or medical applications), special processing/testing/conditions of sale may be available on application to Plessey.

Компания «Океан Электроники» предлагает заключение долгосрочных отношений при поставках импортных электронных компонентов на взаимовыгодных условиях!

Наши преимущества:

- Поставка оригинальных импортных электронных компонентов напрямую с производств Америки, Европы и Азии, а так же с крупнейших складов мира;
- Широкая линейка поставок активных и пассивных импортных электронных компонентов (более 30 млн. наименований);
- Поставка сложных, дефицитных, либо снятых с производства позиций;
- Оперативные сроки поставки под заказ (от 5 рабочих дней);
- Экспресс доставка в любую точку России;
- Помощь Конструкторского Отдела и консультации квалифицированных инженеров;
- Техническая поддержка проекта, помощь в подборе аналогов, поставка прототипов;
- Поставка электронных компонентов под контролем ВП;
- Система менеджмента качества сертифицирована по Международному стандарту ISO 9001;
- При необходимости вся продукция военного и аэрокосмического назначения проходит испытания и сертификацию в лаборатории (по согласованию с заказчиком);
- Поставка специализированных компонентов военного и аэрокосмического уровня качества (Xilinx, Altera, Analog Devices, Intersil, Interpoint, Microsemi, Actel, Aeroflex, Peregrine, VPT, Syfer, Eurofarad, Texas Instruments, MS Kennedy, Miteq, Cobham, E2V, MA-COM, Hittite, Mini-Circuits, General Dynamics и др.);

Компания «Океан Электроники» является официальным дистрибьютором и эксклюзивным представителем в России одного из крупнейших производителей разъемов военного и аэрокосмического назначения «JONHON», а так же официальным дистрибьютором и эксклюзивным представителем в России производителя высокотехнологичных и надежных решений для передачи СВЧ сигналов «FORSTAR».



## JONHON

«JONHON» (основан в 1970 г.)

Разъемы специального, военного и аэрокосмического назначения:

(Применяются в военной, авиационной, аэрокосмической, морской, железнодорожной, горно- и нефтедобывающей отраслях промышленности)

«FORSTAR» (основан в 1998 г.)

ВЧ соединители, коаксиальные кабели, кабельные сборки и микроволновые компоненты:

(Применяются в телекоммуникациях гражданского и специального назначения, в средствах связи, РЛС, а так же военной, авиационной и аэрокосмической отраслях промышленности).



Телефон: 8 (812) 309-75-97 (многоканальный)

Факс: 8 (812) 320-03-32

Электронная почта: [ocean@oceanchips.ru](mailto:ocean@oceanchips.ru)

Web: <http://oceanchips.ru/>

Адрес: 198099, г. Санкт-Петербург, ул. Калинина, д. 2, корп. 4, лит. А