

# MAX16122–MAX16125

## Dual Pushbutton Controllers in Tiny 6-Bump WLP Package

### General Description

The MAX16122–MAX16125 pushbutton controllers with single-supply monitors monitor one or two pushbuttons and generate a hard reset signal if the buttons are pushed and held for a setup delay. These devices make it easy to “hide” the hard reset function in an existing pushbutton, such as a soft power switch. The devices operate from 1.6V to 5.5V and consume a quiescent current of only 5 $\mu$ A at 3V.

The MAX16122–MAX16125 have pin-programmable or resistor-adjustable setup delay. Connect the SEL pin to GND, V<sub>CC</sub>, or leave it unconnected to select the different setup delays (depending on part suffix, see [Table 1a](#)) or connect an external resistor from SEL to GND to set the setup delays (E suffix only, see [Table 1b](#)).

The MAX16124/MAX16125 have one manual reset input ( $\overline{\text{MR}}$ ), a reset output ( $\overline{\text{RESET}}$ ), and a soft reset output ( $\overline{\text{SRESET}}$ ) which mirrors the state of the input. The MAX16122/MAX16123 have two identical manual reset inputs ( $\overline{\text{MR1}}$  and  $\overline{\text{MR2}}$ ) and one reset output ( $\overline{\text{RESET}}$ ). A deglitch block is connected to each input to add a delay to the falling edge with a fixed deglitch period of 20ms ( $t_{\text{DB}}$ ).

The MAX16122–MAX16125 feature a comparator that monitors the input supply voltage. A variety of factory-trimmed threshold options accommodate different supply voltages and tolerances, eliminating external components. The factory-set reset thresholds range from 1.58V to 4.63V to monitor 5V, 3.3V, 2.5V, and 1.8V supplies.

The MAX16122–MAX16125 are offered in a tiny 0.86mm x 1.27mm, 6-bump WLP package and are specified over the automotive temperature range (-40°C to +125°C).

### Benefits and Features

- ◆ **Low Supply Current:** < 5 $\mu$ A (typ) at 3V Over Temperature
- ◆ **Precision Factory-Set V<sub>CC</sub> Monitoring Threshold for 1.8V, 2.5V, 3.3V, and 5V Supplies**
- ◆ **Fixed/Pin-Programmable or Resistor-Adjustable Pushbutton Setup Delay**
- ◆ **Up to 2 Reset Outputs and 2 Debounced Pushbutton Inputs**
- ◆ **Guaranteed  $\overline{\text{RESET}}$  Valid for V<sub>CC</sub> Down to 0.95V**
- ◆ **Active-Low  $\overline{\text{RESET}}$  Output (Push-Pull or Open-Drain)**
- ◆ **Immune to Short Power-Supply Transients**
- ◆ **0.86mm x 1.27mm 6-Bump WLP Package**
- ◆ **-40°C to +125°C Operating Temperature Range**

### Applications

Smartphones  
Tablet PCs  
eBook Readers  
Portable/Battery-Powered Equipment  
Glucose Monitors/Patient Monitors  
Portable Instrumentation

**Ordering Information** appears at end of data sheet.

For related parts and recommended products to use with this part, refer to [www.maximintegrated.com/MAX16122.related](http://www.maximintegrated.com/MAX16122.related).

### Typical Operating Circuits

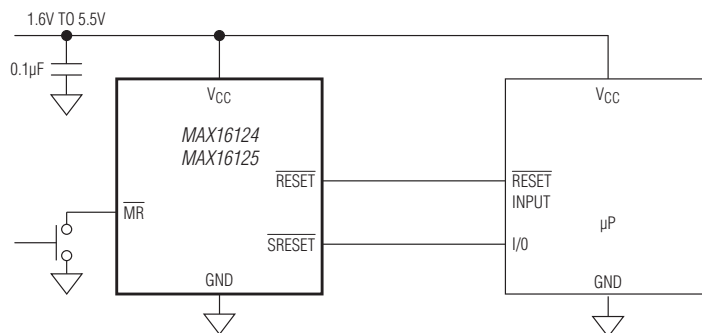

**Typical Operating Circuits (continued) at end of data sheet.**

# MAX16122–MAX16125

## Dual Pushbutton Controllers in Tiny 6-Bump WLP Package

### ABSOLUTE MAXIMUM RATINGS

(All pins referenced to GND)

$V_{CC}$ .....	-0.3V to +6V	Input/Output Current (all pins) .....	20mA
$\overline{RESET}$ , $\overline{SRESET}$ to GND		Continuous Power Dissipation ( $T_A = +70^\circ\text{C}$ ) (Multilayer Board)	
Open-Drain.....	-0.3V to +6V	WLP (derate 10.5mW/ $^\circ\text{C}$ above $+70^\circ\text{C}$ ).....	840mW
Push-Pull.....	-0.3V to ( $V_{CC} + 0.3\text{V}$ )	Operating Temperature Range .....	$-40^\circ\text{C}$ to $+125^\circ\text{C}$
MR, MR1, MR2 .....	-0.3V to +6V	Junction Temperature .....	$+150^\circ\text{C}$
SEL .....	-0.3V to +6V	Storage Temperature Range.....	$-65^\circ\text{C}$ to $+150^\circ\text{C}$
		Soldering Temperature (reflow) .....	$+260^\circ\text{C}$

Stresses beyond those listed under "Absolute Maximum Ratings" may cause permanent damage to the device. These are stress ratings only, and functional operation of the device at these or any other conditions beyond those indicated in the operational sections of the specifications is not implied. Exposure to absolute maximum rating conditions for extended periods may affect device reliability.

### PACKAGE THERMAL CHARACTERISTICS (Note 1)

WLP

Junction-to-Ambient Thermal Resistance ( $\theta_{JA}$ ) ..... $95^\circ\text{C}/\text{W}$

**Note 1:** Package thermal resistances were obtained using the method described in JEDEC specification JESD51-7, using a four-layer board. For detailed information on package thermal considerations, refer to [www.maximintegrated.com/thermal-tutorial](http://www.maximintegrated.com/thermal-tutorial).

### ELECTRICAL CHARACTERISTICS

( $V_{CC} = 1.6\text{V}$  to  $5.5\text{V}$ ,  $T_A = -40^\circ\text{C}$  to  $+125^\circ\text{C}$ , unless otherwise noted. Typical values are at  $T_A = +25^\circ\text{C}$ .) (Note 2)

PARAMETER	SYMBOL	CONDITIONS	MIN	TYP	MAX	UNITS
Operating Voltage Range	$V_{CC}$	$\overline{RESET}$ state guaranteed for $V_{CC} \geq 0.95\text{V}$	1.6		5.5	V
$V_{CC}$ Undervoltage Lockout	$V_{CCUVLO}$			1.25	1.55	V
$V_{CC}$ Supply Current	$I_{CC}$	$V_{CC} = 5\text{V}$ , steady-state condition; $\overline{MR}$ , $\overline{MR1}$ , $\overline{MR2}$ , $\overline{RESET}$ , and $\overline{SRESET}$ not asserted		8	10	$\mu\text{A}$
Supply Current with Oscillator Running	$I_{CC2}$	$V_{CC} = 3\text{V}$		5	10	$\mu\text{A}$
$V_{CC}$ Reset Threshold	$V_{TH}$	$V_{CC}$ falling	-2.5%	$V_{TH}$	+2.5%	V
$V_{CC}$ Reset Threshold Hysteresis	$V_{HYST}$			2		%
Reset Threshold Tempco				30		ppm/ $^\circ\text{C}$
$V_{CC}$ to $\overline{RESET}$ Output Delay	$t_D$	$V_{CC}$ falling at $10\text{mV}/\mu\text{s}$ from ( $V_{TH} + 100\text{mV}$ ) to ( $V_{TH} - 100\text{mV}$ )		10		$\mu\text{s}$
Reset Timeout Period	$t_{RP}$	See Table 2	-10	$t_{RP}$	+10	%
Manual Reset Setup Delay	$t_{SU}$	Internal timing (see Tables 1a, 1b, 1c)	-10	$t_{SU}$	+10	%
Debounce Period	$t_{DB}$		18	20	22	ms

# MAX16122–MAX16125

## Dual Pushbutton Controllers in Tiny 6-Bump WLP Package

### ELECTRICAL CHARACTERISTICS (continued)

( $V_{CC} = 1.6V$  to  $5.5V$ ,  $T_A = -40^{\circ}C$  to  $+125^{\circ}C$ , unless otherwise noted. Typical values are at  $T_A = +25^{\circ}C$ .) (Note 2)

PARAMETER	SYMBOL	CONDITIONS	MIN	TYP	MAX	UNITS
<b>OUTPUTS (<math>\overline{RESET}</math>, <math>\overline{SRESET}</math>)</b>						
$\overline{RESET}$ , $\overline{SRESET}$ Output Low	$V_{OL}$	$V_{CC} = V_{TH(MIN)}$ , $V_{TH} > 4.25V$ , $I_{SINK} = 10mA$			0.4	V
		$V_{CC} = V_{TH(MIN)}$ , $V_{TH} > 2.5V$ , $I_{SINK} = 3.2mA$			0.4	V
		$V_{CC} = V_{TH(MIN)}$ , $V_{TH} > 1.67V$ , $I_{SINK} = 1mA$			0.4	V
		$V_{CC} = V_{TH(MIN)}$ , $V_{TH} > 1V$ , $I_{SINK} = 100\mu A$			0.4	V
		$V_{CC} > 0.95V$ , $V_{CC}$ falling, $I_{SINK} = 15\mu A$			0.4	V
$\overline{RESET}$ , $\overline{SRESET}$ Output High (Push-Pull Outputs)	$V_{OH}$	$V_{CC} > 0.95V$ , $I_{SOURCE} = 15\mu A$	$0.8 \times$ $V_{CC}$			V
		$V_{CC} > 1.2V$ , $I_{SOURCE} = 100\mu A$	$0.8 \times$ $V_{CC}$			V
		$V_{CC} > 1.67V$ , $I_{SOURCE} = 150\mu A$	$0.8 \times$ $V_{CC}$			V
		$V_{CC} > 2.7V$ , $I_{SOURCE} = 500\mu A$	$0.8 \times$ $V_{CC}$			V
		$V_{CC} > 4.5V$ , $I_{SOURCE} = 800\mu A$	$0.8 \times$ $V_{CC}$			V
$\overline{RESET}$ , $\overline{SRESET}$ Output Leakage Current (Open-Drain Outputs)					1	$\mu A$
<b>MANUAL RESET INPUTS (<math>\overline{MR}</math>, <math>\overline{MR1}</math>, <math>\overline{MR2}</math>)</b>						
$\overline{MR1}$ , $\overline{MR2}$ , $\overline{MR}$ Input Voltage Low	$V_{IL}$				$0.3 \times V_{CC}$	V
$\overline{MR1}$ , $\overline{MR2}$ , $\overline{MR}$ Input Voltage High	$V_{IH}$				$0.7 \times V_{CC}$	V
Manual Reset Minimum Pulse Width				1		$\mu s$
Manual Reset Glitch Rejection				100		ns
Manual Reset to Soft Reset Delay	$t_{MRD}$			200		ns
$\overline{MR1}$ , $\overline{MR2}$ , $\overline{MR}$ Internal Pullup Resistance			25	50	80	$k\Omega$
<b>SELECT (<math>\overline{SEL}</math>) LOGIC INPUT</b>						
$\overline{SEL}$ Input Low Voltage					$0.15 \times$ $V_{CC}$	V
$\overline{SEL}$ Input High Voltage			$0.85 \times$ $V_{CC}$			V
$\overline{SEL}$ Input Leakage			-8		+8	$\mu A$

**Note 2:** All parameters are production tested at  $T_A = +25^{\circ}C$ . Limits over the operating temperature range are guaranteed by design.

# MAX16122–MAX16125

## Dual Pushbutton Controllers in Tiny 6-Bump WLP Package

### Typical Operating Characteristics

( $V_{CC} = 5V$ , MAX16125WTDB29+,  $T_A = +25^\circ C$ , unless otherwise noted.)

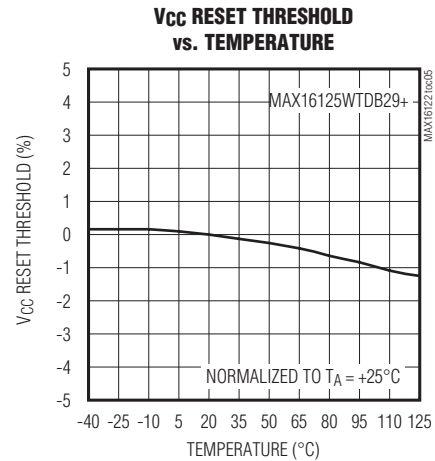
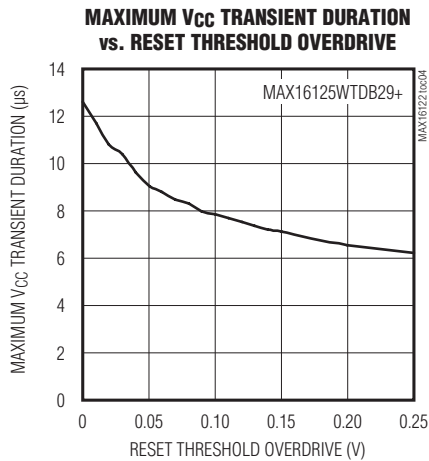
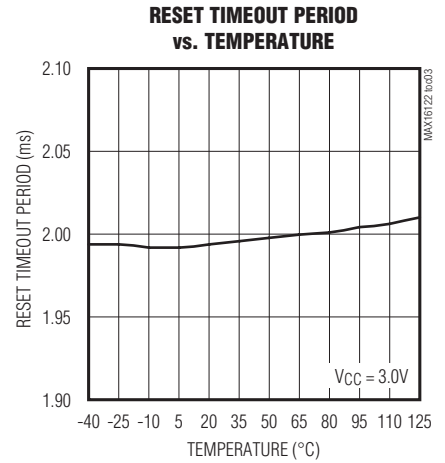
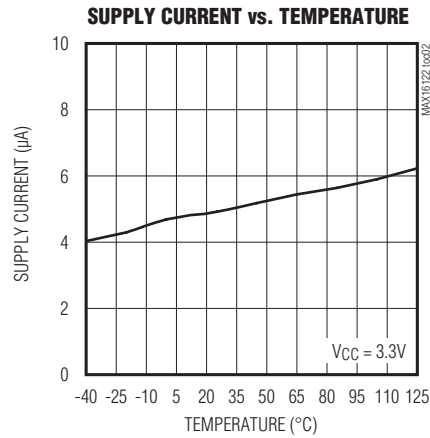
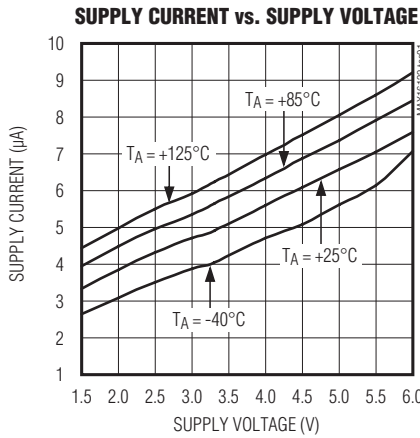

# MAX16122–MAX16125

## Dual Pushbutton Controllers in Tiny 6-Bump WLP Package

### Typical Operating Characteristics (continued)

( $V_{CC} = 5V$ , MAX16125WTDB29+,  $T_A = +25^\circ C$ , unless otherwise noted.)

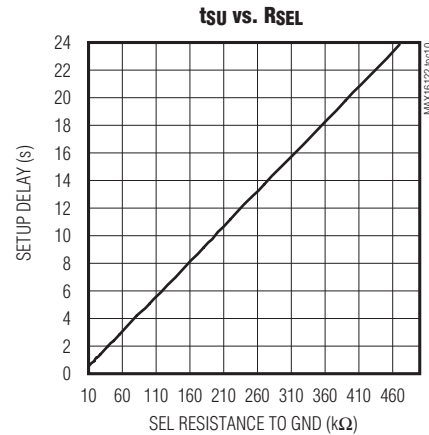
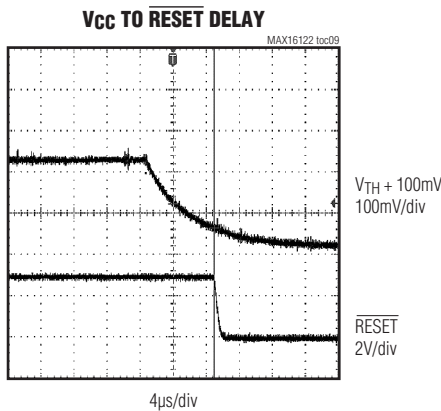
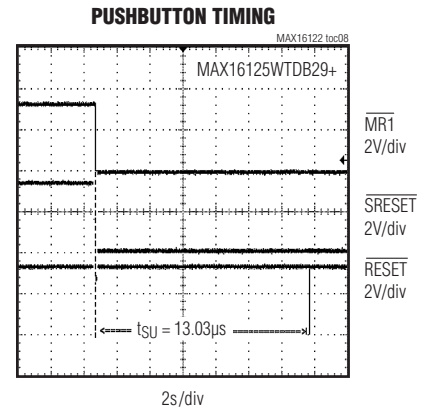
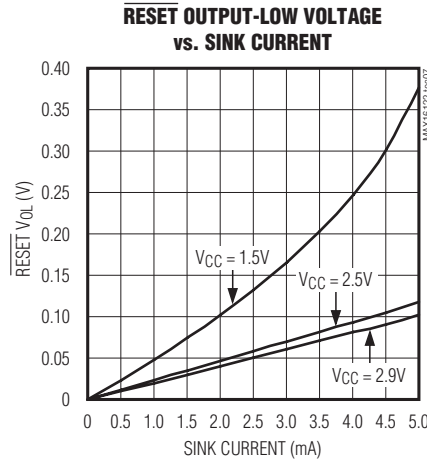
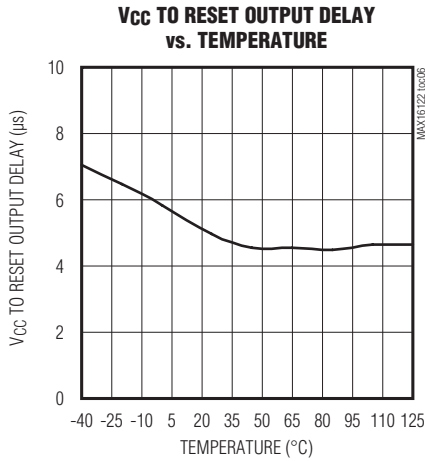

# MAX16122–MAX16125

## Dual Pushbutton Controllers in Tiny 6-Bump WLP Package

### Bump Configurations

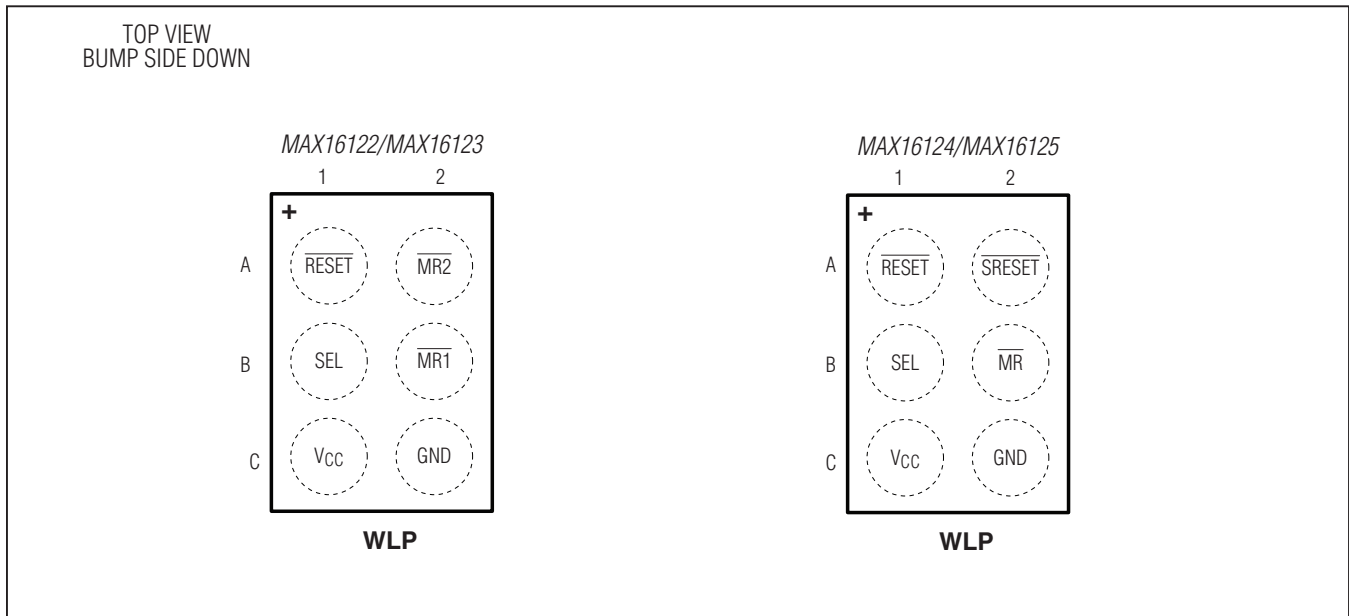

### Bump Description

BUMP		NAME	FUNCTION
MAX16122/ MAX16123	MAX16124/ MAX16125		
A1	A1	$\overline{\text{RESET}}$	Active-Low Reset Output. $\overline{\text{RESET}}$ is either an open-drain or a push-pull output (see the <i>Selector Guide</i> ). $\overline{\text{RESET}}$ asserts low when $V_{\text{CC}}$ drops below the selected threshold and remains low for the $V_{\text{CC}}$ reset timeout period after $V_{\text{CC}}$ rises above the reset threshold. The $\overline{\text{RESET}}$ one-shot asserts low for the reset timeout period when the manual reset input is asserted longer than the setup delay. The open-drain output requires an external pullup resistor.
—	A2	$\overline{\text{SRESET}}$	Soft Reset Output. $\overline{\text{SRESET}}$ is the debounced version of $\overline{\text{MR}}$ .
B1	B1	SEL	Setup Delay Select Input. Connect SEL to $V_{\text{CC}}$ , GND, or leave unconnected to select a desired setup delay (see Table 1a); or connect an external resistor between SEL and GND to select a desired setup delay (E suffix only, see Tables 1a and 1b).
—	B2	$\overline{\text{MR}}$	Manual Reset Input. Internal 50k $\Omega$ pullup to $V_{\text{CC}}$ . Pull $\overline{\text{MR}}$ low for the setup delay ( $t_{\text{SU}}$ ) to one-shot pulse $\overline{\text{RESET}}$ for the reset timeout period.

# MAX16122–MAX16125

## Dual Pushbutton Controllers in Tiny 6-Bump WLP Package

### Bump Description (continued)

BUMP		NAME	FUNCTION
MAX16122/ MAX16123	MAX16124/ MAX16125		
C1	C1	V <sub>CC</sub>	Power-Supply Input. V <sub>CC</sub> provides power to the device and is also a monitored voltage. When V <sub>CC</sub> drops below the selected threshold, $\overline{\text{RESET}}$ asserts low and remains low for the reset timeout period after V <sub>CC</sub> rises above the threshold. Bypass V <sub>CC</sub> to GND with a 0.1µF capacitor.
C2	C2	GND	Ground
B2	—	$\overline{\text{MR1}}$	Active-Low Manual Reset Input 1. Internal 50kΩ pullup to V <sub>CC</sub> . Pull both $\overline{\text{MR1}}$ and $\overline{\text{MR2}}$ low for the setup delay (t <sub>SU</sub> ) to one-shot pulse $\overline{\text{RESET}}$ for the reset timeout period.
A2	—	$\overline{\text{MR2}}$	Active-Low Manual Reset Input 2. Internal 50kΩ pullup to V <sub>CC</sub> . Pull the $\overline{\text{MR2}}$ and $\overline{\text{MR1}}$ low for the setup delay (t <sub>SU</sub> ) to one-shot pulse $\overline{\text{RESET}}$ for the reset timeout period.

### Detailed Description

The MAX16122–MAX16125 low-current microprocessor reset circuits feature single or dual manual reset inputs with an extended setup period. The devices also feature an internal comparator to monitor 5V, 3.3V, 2.5V, and 1.8V supplies.

When the monitored supply voltage drops below the specified threshold, the active-low  $\overline{\text{RESET}}$  output asserts low and remains low for the reset timeout period (t<sub>RP</sub>). The  $\overline{\text{RESET}}$  output is one-shot pulse asserted for the reset timeout period. Supply voltage reset threshold is selectable through part suffix, see [Table 3](#).

Connect SEL to GND, V<sub>CC</sub>, or leave unconnected to select the different setup delays (depending on part suffix, see [Table 1a](#)), or connect to an external resistor to set the setup delays (E suffix only, see [Table 1b](#)).

The MAX16124/MAX16125 have one manual reset input ( $\overline{\text{MR}}$ ), one reset output ( $\overline{\text{RESET}}$ ), and one soft reset output ( $\overline{\text{SRESET}}$ ). The MAX16122/MAX16123 have two identical manual reset inputs ( $\overline{\text{MR1}}$  and  $\overline{\text{MR2}}$ ) and one reset output ( $\overline{\text{RESET}}$ ). A deglitch block is connected to each manual reset input to add a delay to the falling edge with a fixed deglitch period of 20ms (t<sub>DB</sub>).

### Resistor-Adjusted Setup Delay

For the MAX16122–MAX16125 with the E setup delay suffix (MAX1612\_WTE\_+T), a resistor connected from SEL to GND sets the setup delay. [Table 1b](#) shows common resistor values and the resulting setup delays. For resistor values not in the table, use the following formula to compute the setup delay:

$$t_{\text{SU}} = \frac{R}{20}$$

where R is the resistor value in kΩ and t<sub>SU</sub> is the resulting setup delay in seconds. For best results, use resistor values between 10kΩ and 500kΩ.

### Reset Output

The reset output is typically connected to the reset input of a microprocessor (µP). A µP's reset input starts or restarts the µP in a known state. The MAX16122–MAX16125 µP supervisory circuits provide the reset logic to prevent code-execution errors during power-up, power-down, and brownout conditions (see the [Typical Operating Circuits](#)).

The MAX16122/MAX16123 have a reset output  $\overline{\text{RESET}}$ . The MAX16124/MAX16125 have a reset output  $\overline{\text{RESET}}$  and a soft-reset output  $\overline{\text{SRESET}}$  which is the debounced “mirror image” of  $\overline{\text{MR}}$  (see [Figure 1a](#)).

# MAX16122–MAX16125

## Dual Pushbutton Controllers in Tiny 6-Bump WLP Package

All reset outputs are either active-low open-drain or active-low push-pull (see the [Selector Guide](#)).  $\overline{\text{RESET}}$  changes from high to low whenever the monitored voltage  $V_{CC}$  drops below the reset threshold voltage. Once  $V_{CC}$  exceeds its respective reset threshold voltage,  $\overline{\text{RESET}}$  remains low for the reset timeout period ( $t_{RP}$ ) and then goes high.  $\overline{\text{RESET}}$  is one-shot pulsed whenever selected manual reset inputs are asserted longer than the setup delay ( $t_{SU}$ ).  $\overline{\text{RESET}}$  stays asserted for the normal reset timeout period.

$\overline{\text{RESET}}$  is guaranteed to be in the proper output logic state for  $V_{CC} \geq 0.95\text{V}$ . For applications requiring valid reset logic when  $V_{CC}$  is less than 0.95V, see the [Ensuring a Valid  \$\overline{\text{RESET}}\$  Output Down to  \$V\_{CC} = 0\text{V}\$  \(Push-Pull  \$\overline{\text{RESET}}\$  Output\)](#) section.

### Manual Reset Input

Each device in the MAX16122–MAX16125 family includes at least one manual reset input, which must be held logic-low for an extended setup period ( $t_{SU}$ ) before the  $\overline{\text{RESET}}$  output asserts. An internal pullup resistor is connected to each manual reset input. When valid manual reset input conditions/setup periods are met, the  $\overline{\text{RESET}}$  output is

pulsed low for the reset timeout period (see [Table 2](#)). Existing front-panel pushbutton switches (i.e., power-on/off, channel up/down, or mode select) can be used to drive the manual reset inputs. The extended manual reset setup period prevents nuisance system resets during normal front-panel usage or resulting from inadvertent short-term pushbutton closure.

The MAX16124/MAX16125 include a single manual reset input ( $\overline{\text{MR}}$ ) and two reset outputs ( $\overline{\text{RESET}}$  and  $\overline{\text{SRESET}}$ ). The MAX16122/MAX16123 include two manual reset inputs ( $\overline{\text{MR1}}$  and  $\overline{\text{MR2}}$ ) and one reset output,  $\overline{\text{RESET}}$ . For dual  $\overline{\text{MR1}}$  and  $\overline{\text{MR2}}$  devices, both inputs must be simultaneously pulled low and held for the extended setup period ( $t_{SU}$ ) before the reset output is pulsed. The dual extended setup provides greater protection from nuisance resets.

The MAX16122–MAX16125  $\overline{\text{RESET}}$  output is asserted once for the reset timeout period after each valid manual reset input condition. At least one manual reset input must be released (go high) and then be driven low for the extended setup period before  $\overline{\text{RESET}}$  asserts again. Internal timing circuitry debounces low-to-high manual reset logic transitions, so no external circuitry is required.

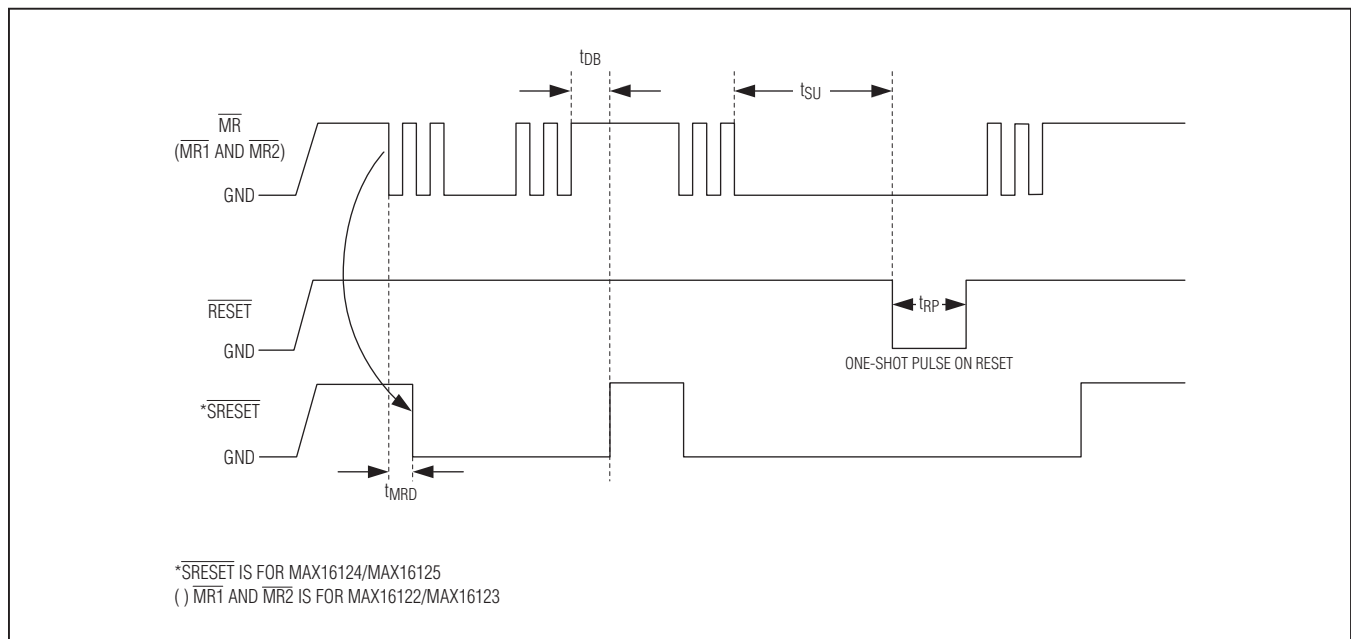

Figure 1a. Reset Timing Diagram



# MAX16122–MAX16125

## Dual Pushbutton Controllers in Tiny 6-Bump WLP Package

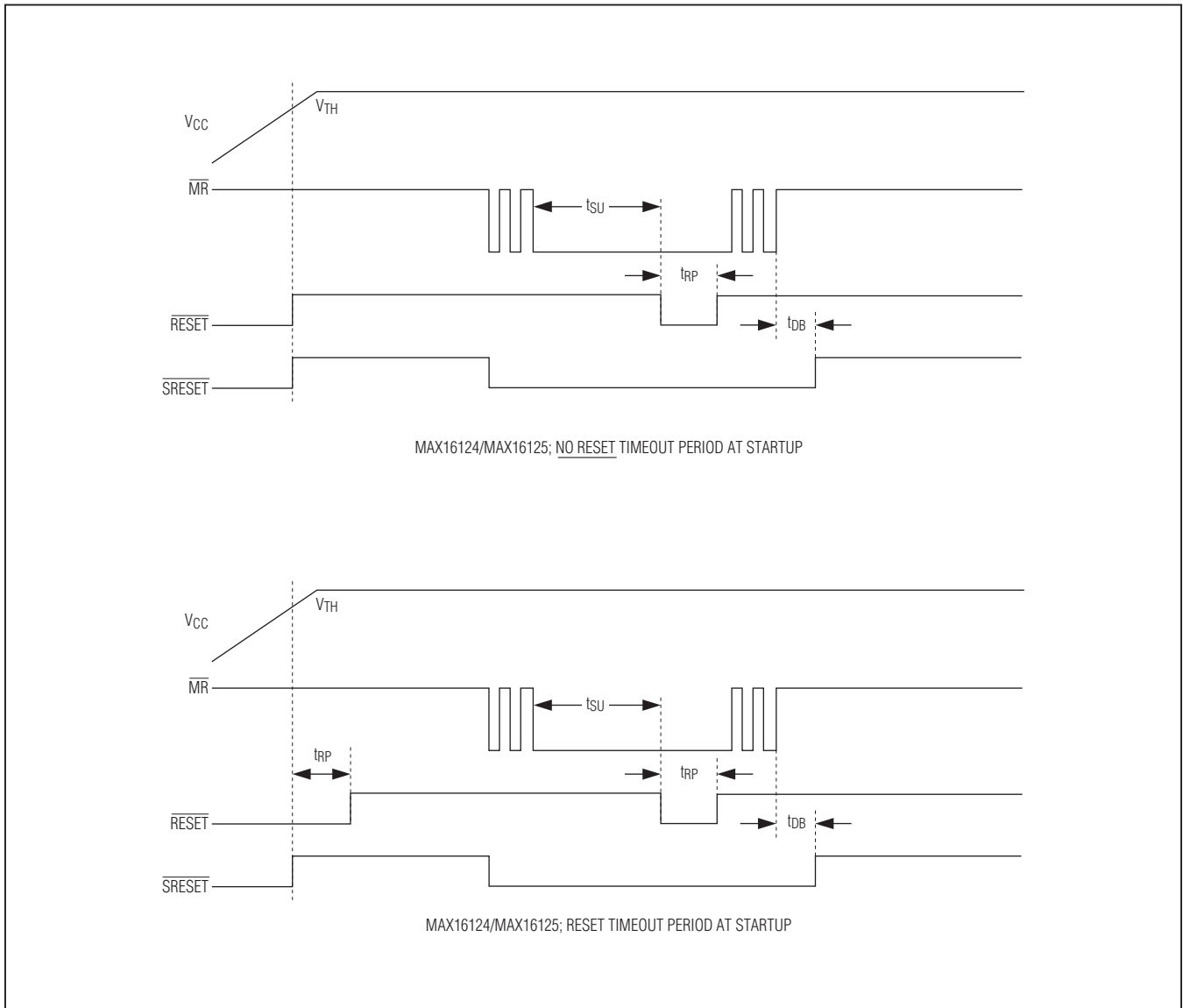

Figure 1b. Timeout Periods at Startup

# MAX16122–MAX16125

## Dual Pushbutton Controllers in Tiny 6-Bump WLP Package

### Supply Voltage Monitor

The MAX16122–MAX16125 have an internal comparator with a programmable trip threshold to monitor the supply voltage. The  $V_{CC}$  monitoring thresholds are selectable through the part number suffix (see the [Ordering Information](#) and [Table 3](#)).

### Applications Information

#### Falling $V_{CC}$ Transients

In addition to issuing a reset to the  $\mu\text{P}$  during power-up, power-down, and brownout conditions, the MAX16122–MAX16125 are relatively immune to short-duration falling  $V_{CC}$  transients (glitches). The [Typical Operating Characteristics](#) show the Maximum Transient Duration vs.  $V_{CC}$  Overdrive graph for which the MAX16122–MAX16125 do not generate a reset pulse. This graph was generated using a falling pulse applied to  $V_{CC}$  starting above the actual reset threshold and ending below the threshold by the magnitude indicated ( $V_{CC}$  overdrive). The graph indicates the typical maximum pulse width that a falling transient can have without initiating a reset pulse. As the magnitude of the transient increases (go farther below the reset threshold), the maximum allowable pulse width decreases.

#### Ensuring a Valid $\overline{\text{RESET}}$ Output Down to $V_{CC} = 0\text{V}$ (Push-Pull $\overline{\text{RESET}}$ Output)

The MAX16122–MAX16125 guarantee proper operation down to  $V_{CC} = 0.95\text{V}$ . In applications that require valid reset levels down to  $V_{CC} = 0\text{V}$ , add a pulldown resistor between  $\overline{\text{RESET}}$  and GND for the push-pull outputs (MAX16122/MAX16124). The resistor sinks any stray

leakage currents, holding  $\overline{\text{RESET}}$  low ([Figure 2](#)). The resistor value used is not critical, but it must be small enough not to overload the  $\overline{\text{RESET}}$  output when  $V_{CC}$  is above the reset threshold. For most applications, use  $100\text{k}\Omega$  to  $1\text{M}\Omega$ . This scheme does not work with open-drain outputs of the MAX16123/MAX16125.

#### Layout and Bypassing

Ensure  $0.1\mu\text{F}$  (minimum) capacitance is connected from  $V_{CC}$  to GND.

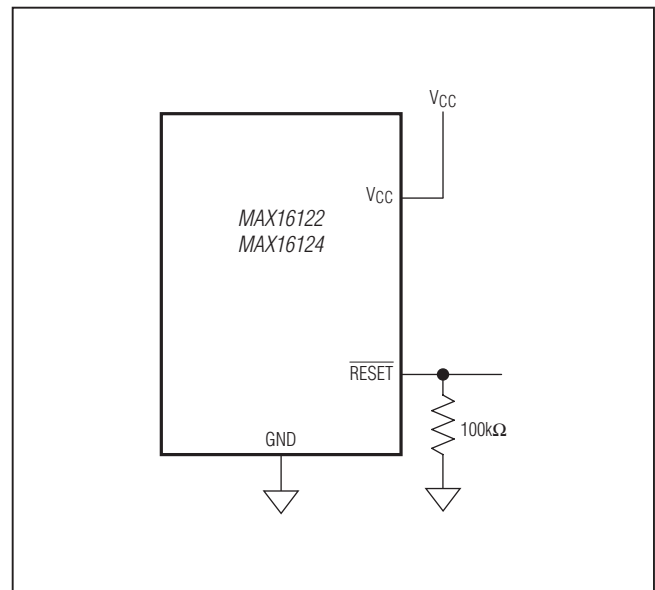
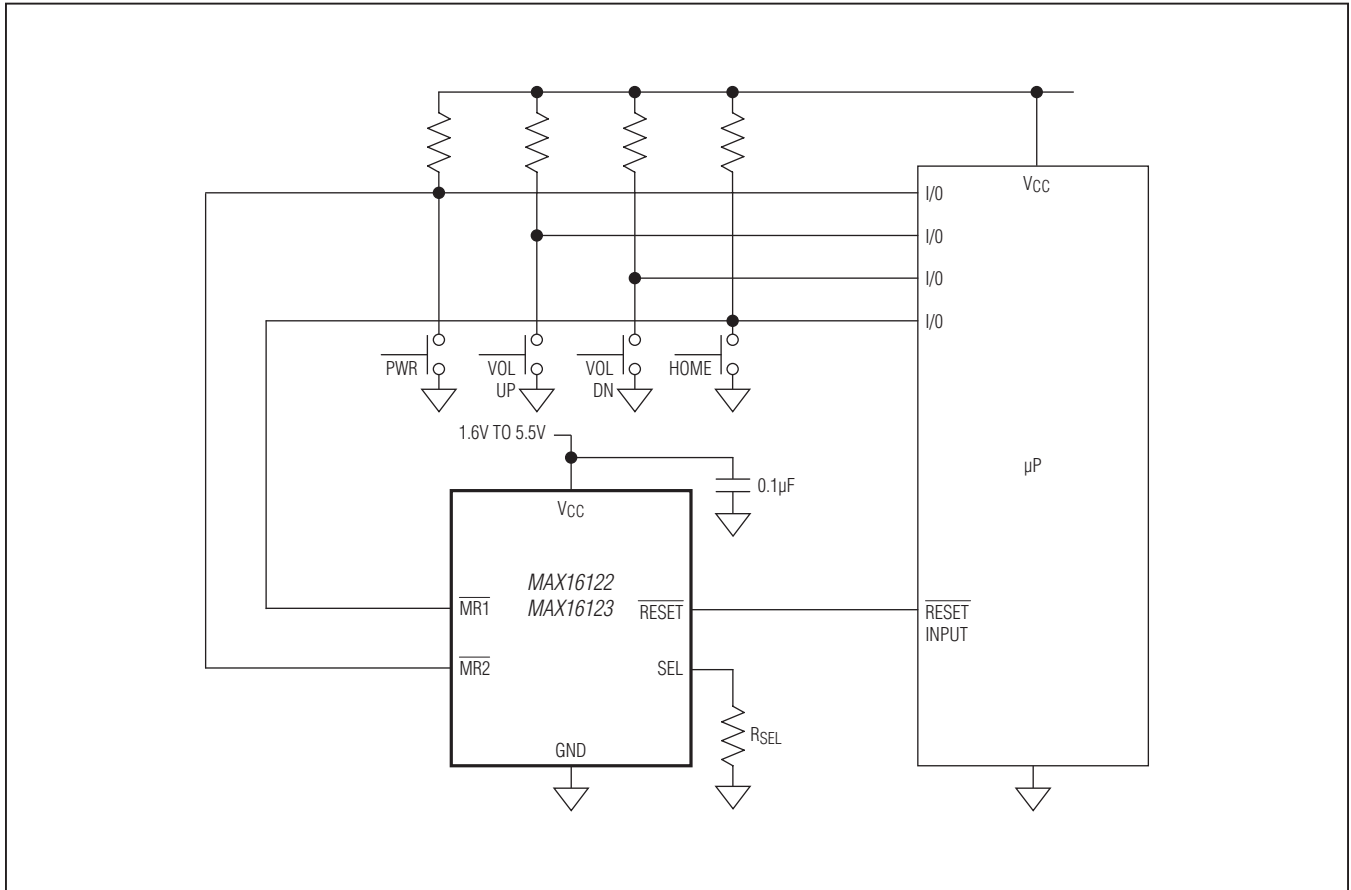

Figure 2. Ensuring  $\overline{\text{RESET}}$  Output to  $V_{CC} = 0\text{V}$

# MAX16122–MAX16125

## Dual Pushbutton Controllers in Tiny 6-Bump WLP Package

*Typical Operating Circuits (continued)*



# MAX16122–MAX16125

## Dual Pushbutton Controllers in Tiny 6-Bump WLP Package

### Functional Diagrams

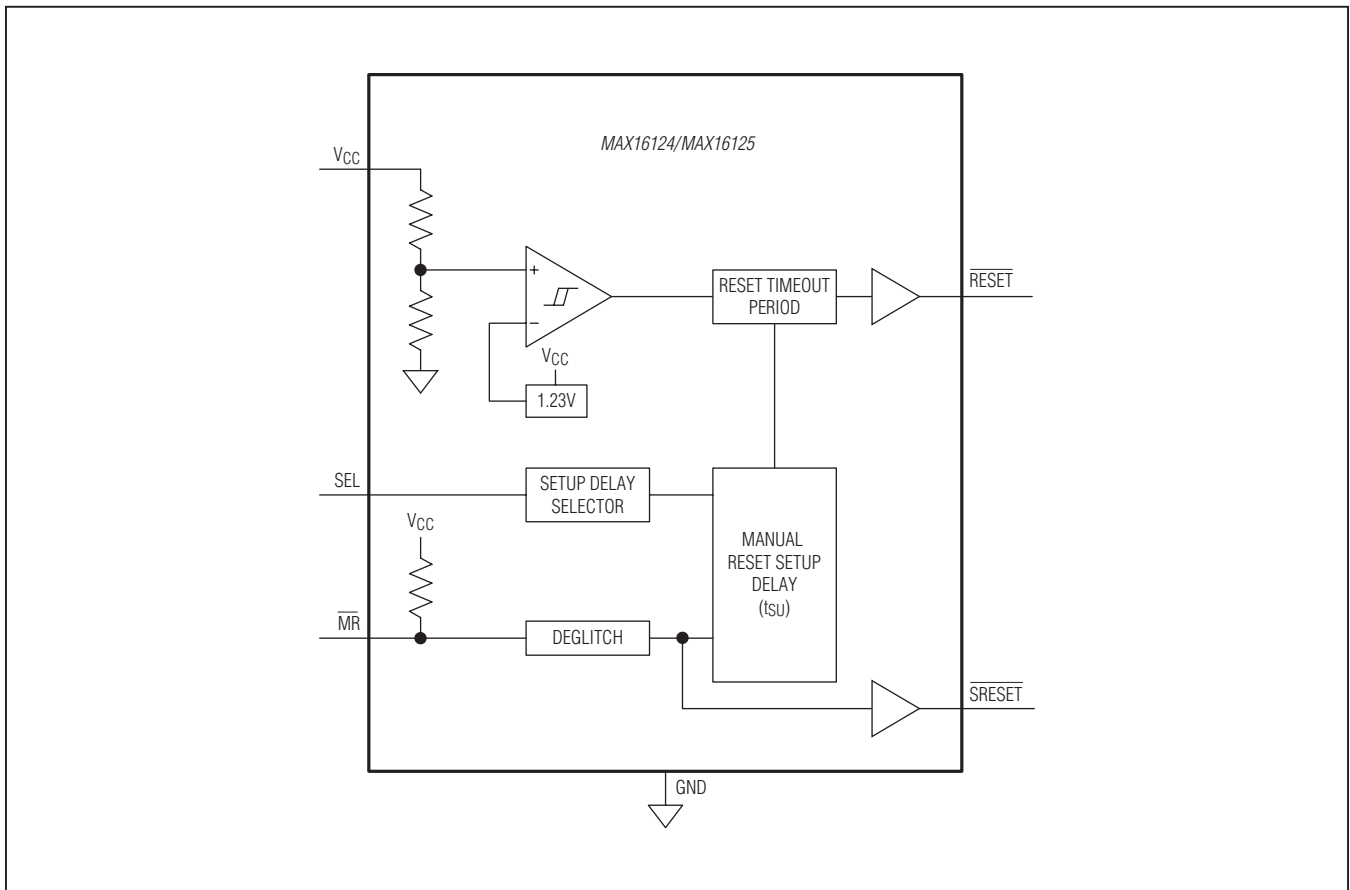

# MAX16122–MAX16125

## Dual Pushbutton Controllers in Tiny 6-Bump WLP Package

*Functional Diagrams (continued)*

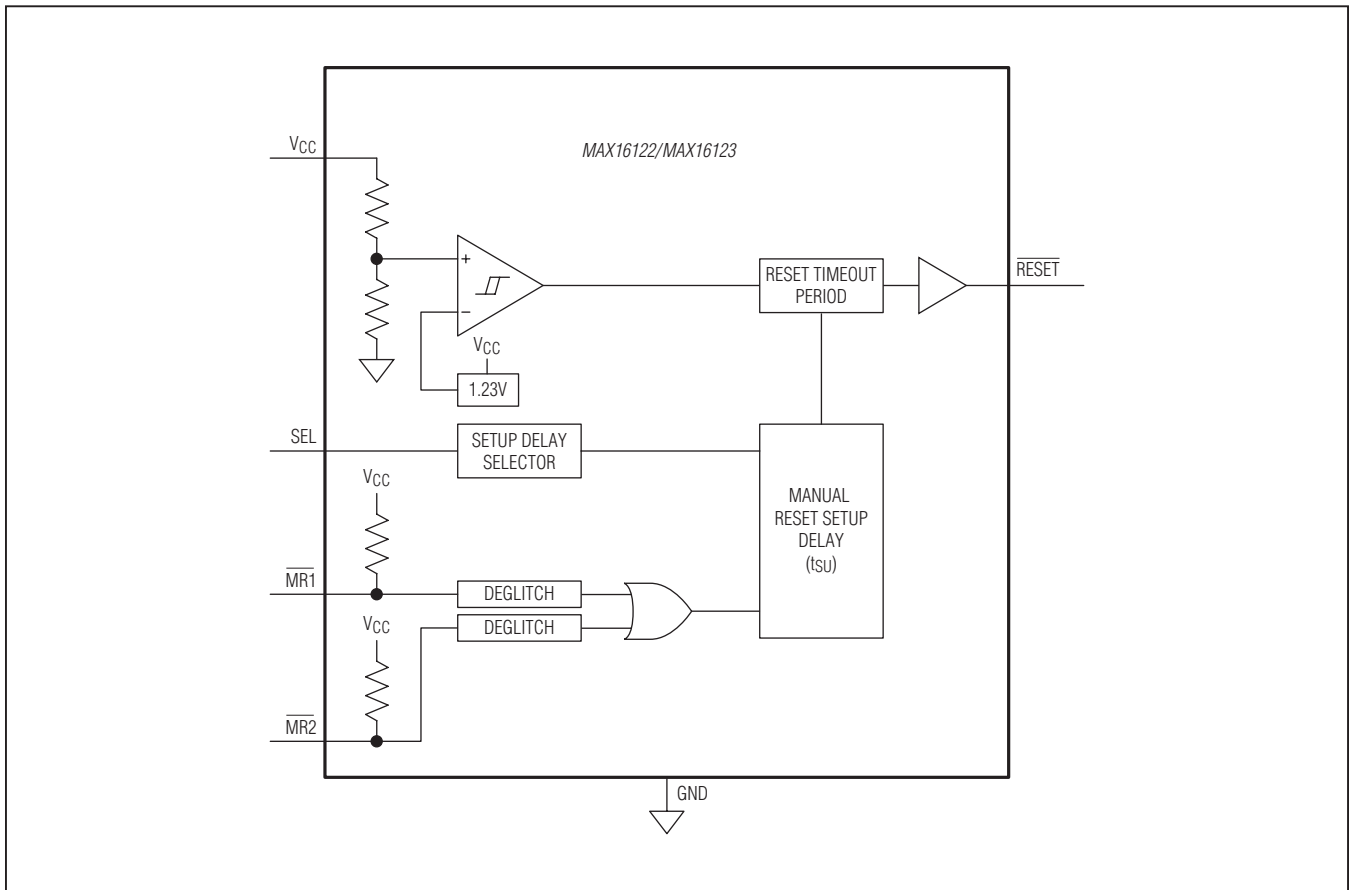

# MAX16122–MAX16125

## Dual Pushbutton Controllers in Tiny 6-Bump WLP Package

**Table 1a. SEL Pin Connection Setup Delays (t<sub>SU</sub>)**

PART SUFFIX	SETUP DELAYS (s)		
	SEL = GND	SEL = UNCONNECTED	SEL = V <sub>CC</sub>
A	0.5	1	2
B	3	4	5
C	6	8	10
D	13	15	17
E	See Table 1b		

**Table 1b. Resistor-Adjusted Setup Delays (t<sub>SU</sub>)**

RESISTOR (kΩ)	SETUP DELAYS (s)
10	0.5
18	0.9
22	1.1
27	1.35
39	1.95
47	2.35
56	2.8
82	4.1
100	5
180	9
220	11

**Table 2. Reset Timeouts (t<sub>RP</sub>)**

PART SUFFIX	MINIMUM RESET TIMEOUT (ms)
A	0.9
B	1.8
C	3.6
D	7.2
E	14.4
F	28.8
G	57.6
H	86.4
I	115.2
J	172.8
K	230.4
L	259.2
M	345.6
N	460.8
O	691.2
P	921.6
Q	1843.2
R	3686.4
S	7372.8

**Table 3. V<sub>CC</sub> Reset Threshold Voltage (V<sub>TH</sub>)**

SUFFIX	V <sub>CC</sub> RESET THRESHOLD VOLTAGE (V) (typ)
00	No Monitoring
16	1.58
17	1.67
22	2.19
23	2.32
29	2.93
31	3.08
44	4.38
46	4.63

# MAX16122–MAX16125

## Dual Pushbutton Controllers in Tiny 6-Bump WLP Package

### Ordering Information

PART	TEMP RANGE	PIN-PACKAGE
MAX16122WT____+T*	-40°C to +125°C	6 WLP
MAX16123WT____+T*	-40°C to +125°C	6 WLP
MAX16124WT____+T*	-40°C to +125°C	6 WLP
MAX16125WT____+T	-40°C to +125°C	6 WLP

**Note:** Insert the desired setup delay (A to Q, from [Table 1a](#)) into the blank following the letters WT. Insert the letter corresponding to the desired minimum reset timeout period (A to S, from [Table 2](#)) into the blank following the setup delay suffix. Insert the two digit number corresponding to the desired nominal reset threshold (from [Table 3](#)) into the blanks following the reset timeout suffix.

+Denotes a lead(Pb)-free/RoHS-compliant package. Devices are available only in lead-free packaging.

T = Tape and reel.

\*Future product—Contact factory for availability.

### Selector Guide

PART	DUAL MANUAL RESET INPUT	$\overline{\text{SRESET}}$	SEL	ACTIVE-LOW RESET OUTPUT
MAX16122WT____+T	√	—	√	Push-pull
MAX16123WT____+T	√	—	√	Open-drain
MAX16124WT____+T	—	√	√	Push-Pull
MAX16125WT____+T	—	√	√	Open-drain

**Note:** MAX16125WTDB29+T is a standard option. For additional options, please contact factory.

### Chip Information

PROCESS: BiCMOS

### Package Information

For the latest package outline information and land patterns (footprints), go to [www.maximintegrated.com/packages](http://www.maximintegrated.com/packages). Note that a "+", "#", or "-" in the package code indicates RoHS status only. Package drawings may show a different suffix character, but the drawing pertains to the package regardless of RoHS status.

PACKAGE TYPE	PACKAGE CODE	OUTLINE NO.	LAND PATTERN NO.
WLP	W61F0+1	<a href="#">21-0217</a>	Refer to <a href="#">Application Note 1891</a>

# MAX16122–MAX16125

## Dual Pushbutton Controllers in Tiny 6-Bump WLP Package

### *Revision History*

REVISION NUMBER	REVISION DATE	DESCRIPTION	PAGES CHANGED
0	7/12	Initial release	—
1	11/14	No IV OPNs in <i>Ordering Information</i> ; removed automotive reference from <i>Applications</i> section	1



Maxim Integrated cannot assume responsibility for use of any circuitry other than circuitry entirely embodied in a Maxim Integrated product. No circuit patent licenses are implied. Maxim Integrated reserves the right to change the circuitry and specifications without notice at any time. The parametric values (min and max limits) shown in the Electrical Characteristics table are guaranteed. Other parametric values quoted in this data sheet are provided for guidance.

**Maxim Integrated 160 Rio Robles, San Jose, CA 95134 USA 1-408-601-1000**

16



Компания «Океан Электроники» предлагает заключение долгосрочных отношений при поставках импортных электронных компонентов на взаимовыгодных условиях!

Наши преимущества:

- Поставка оригинальных импортных электронных компонентов напрямую с производств Америки, Европы и Азии, а так же с крупнейших складов мира;
- Широкая линейка поставок активных и пассивных импортных электронных компонентов (более 30 млн. наименований);
- Поставка сложных, дефицитных, либо снятых с производства позиций;
- Оперативные сроки поставки под заказ (от 5 рабочих дней);
- Экспресс доставка в любую точку России;
- Помощь Конструкторского Отдела и консультации квалифицированных инженеров;
- Техническая поддержка проекта, помощь в подборе аналогов, поставка прототипов;
- Поставка электронных компонентов под контролем ВП;
- Система менеджмента качества сертифицирована по Международному стандарту ISO 9001;
- При необходимости вся продукция военного и аэрокосмического назначения проходит испытания и сертификацию в лаборатории (по согласованию с заказчиком);
- Поставка специализированных компонентов военного и аэрокосмического уровня качества (Xilinx, Altera, Analog Devices, Intersil, Interpoint, Microsemi, Actel, Aeroflex, Peregrine, VPT, Syfer, Eurofarad, Texas Instruments, MS Kennedy, Miteq, Cobham, E2V, MA-COM, Hittite, Mini-Circuits, General Dynamics и др.);

Компания «Океан Электроники» является официальным дистрибьютором и эксклюзивным представителем в России одного из крупнейших производителей разъемов военного и аэрокосмического назначения «JONHON», а так же официальным дистрибьютором и эксклюзивным представителем в России производителя высокотехнологичных и надежных решений для передачи СВЧ сигналов «FORSTAR».



## JONHON

«JONHON» (основан в 1970 г.)

Разъемы специального, военного и аэрокосмического назначения:

(Применяются в военной, авиационной, аэрокосмической, морской, железнодорожной, горно- и нефтедобывающей отраслях промышленности)

«FORSTAR» (основан в 1998 г.)

ВЧ соединители, коаксиальные кабели, кабельные сборки и микроволновые компоненты:

(Применяются в телекоммуникациях гражданского и специального назначения, в средствах связи, РЛС, а так же военной, авиационной и аэрокосмической отраслях промышленности).



Телефон: 8 (812) 309-75-97 (многоканальный)

Факс: 8 (812) 320-03-32

Электронная почта: [ocean@oceanchips.ru](mailto:ocean@oceanchips.ru)

Web: <http://oceanchips.ru/>

Адрес: 198099, г. Санкт-Петербург, ул. Калинина, д. 2, корп. 4, лит. А