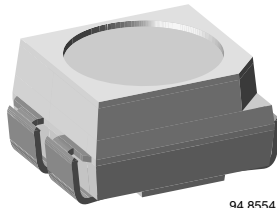


## Silicon NPN Phototransistor, RoHS Compliant



94 8554

### DESCRIPTION

VENT4700 is a high speed silicon NPN epitaxial planar phototransistor in a miniature PLCC-3 package for surface mounting on printed boards. The device is sensitive to visible and near infrared radiation.

### FEATURES

- Package type: surface mount
- Package form: PLCC-3
- Dimensions (L x W x H in mm): 3.5 x 2.8 x 1.75
- High photo sensitivity
- High radiant sensitivity
- Suitable for visible and near infrared radiation
- Fast response times
- Angle of half sensitivity:  $\varphi = \pm 60^\circ$
- Base terminal connected
- Package notch indicates collector
- Package matched with IR emitter series VSML3710
- Floor life: 4 weeks, MSL 2a, acc. J-STD-020
- Lead (Pb)-free reflow soldering
- Lead (Pb)-free component in accordance with RoHS 2002/95/EC and WEEE 2002/96/EC


**RoHS**  
COMPLIANT

### APPLICATIONS

- Photo interrupters
- Miniature switches
- Counters
- Encoders
- Position sensors
- Light sensors

### PRODUCT SUMMARY

COMPONENT	$I_{ca}$ (mA)	$\varphi$ (deg)	$\lambda_{0.1}$ (nm)
VENT4700	0.5	$\pm 60$	450 to 1080

**Note**

Test conditions see table "Basic Characteristics"

### ORDERING INFORMATION

ORDERING CODE	PACKAGING	REMARKS	PACKAGE FORM
VENT4700-GS08	Tape and reel	MOQ: 7500 pcs, 1500 pcs/reel	PLCC-3
VENT4700-GS18	Tape and reel	MOQ: 8000 pcs, 8000 pcs/reel	PLCC-3

**Note**

MOQ: minimum order quantity

### ABSOLUTE MAXIMUM RATINGS

PARAMETER	TEST CONDITION	SYMBOL	VALUE	UNIT
Collector emitter voltage		$V_{CEO}$	70	V
Emitter collector voltage		$V_{ECO}$	5	V
Collector current		$I_C$	50	mA
Collector peak current	$t_p/T \leq 0.1, t_p \leq 10 \mu s$	$I_{CM}$	100	mA
Power dissipation		$P_V$	100	mW

ABSOLUTE MAXIMUM RATINGS				
PARAMETER	TEST CONDITION	SYMBOL	VALUE	UNIT
Junction temperature		$T_j$	100	$^{\circ}\text{C}$
Operating temperature range		$T_{\text{amb}}$	- 40 to + 100	$^{\circ}\text{C}$
Storage temperature range		$T_{\text{stg}}$	- 40 to + 100	$^{\circ}\text{C}$
Soldering temperature	Acc. reflow solder profile fig. 10	$T_{\text{sd}}$	260	$^{\circ}\text{C}$
Thermal resistance junction/ambient	Soldered on PCB with pad dimensions: 4 mm x 4 mm	$R_{\text{thJA}}$	400	K/W

**Note**

$T_{\text{amb}} = 25^{\circ}\text{C}$ , unless otherwise specified

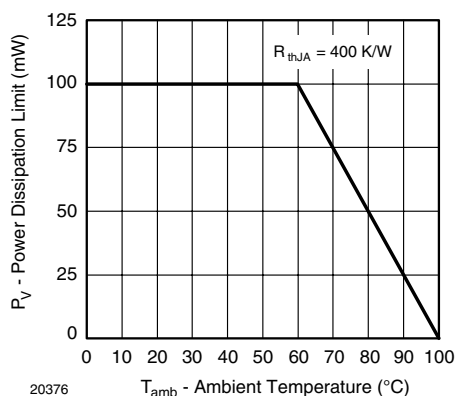


Fig. 1 - Power Dissipation Limit vs. Ambient Temperature

BASIC CHARACTERISTICS						
PARAMETER	TEST CONDITION	SYMBOL	MIN.	TYP.	MAX.	UNIT
Collector emitter breakdown voltage	$I_C = 1$ mA	$V_{(\text{BR})\text{CEO}}$	70			V
Collector emitter dark current	$V_{\text{CE}} = 20$ V, $E = 0$	$I_{\text{CEO}}$		1	200	nA
Collector emitter capacitance	$V_{\text{CE}} = 5$ V, $f = 1$ MHz, $E = 0$	$C_{\text{CEO}}$		3		pF
Collector light current	$E_e = 1$ mW/cm <sup>2</sup> , $\lambda = 950$ nm, $V_{\text{CE}} = 5$ V	$I_{\text{ca}}$	0.25	0.5		mA
Angle of half sensitivity		$\phi$		$\pm 60$		deg
Wavelength of peak sensitivity		$\lambda_p$		850		nm
Range of spectral bandwidth		$\lambda_{0.1}$		450 to 1080		nm
Collector emitter saturation voltage	$E_e = 1$ mW/cm <sup>2</sup> , $\lambda = 950$ nm, $I_C = 0.1$ mA	$V_{\text{CEsat}}$		0.15	0.3	V
Rise time, fall time	$V_S = 5$ V, $I_C = 1$ mA, $\lambda = 950$ nm, $R_L = 1$ k $\Omega$	$t_r/t_f$		6		$\mu\text{s}$
	$V_S = 5$ V, $I_C = 1$ mA, $\lambda = 950$ nm, $R_L = 100$ $\Omega$	$t_r/t_f$		2		$\mu\text{s}$
Cut-off frequency	$V_S = 5$ V, $I_C = 2$ mA, $R_L = 100$ $\Omega$	$f_c$		180		kHz

**Note**

$T_{\text{amb}} = 25^{\circ}\text{C}$ , unless otherwise specified

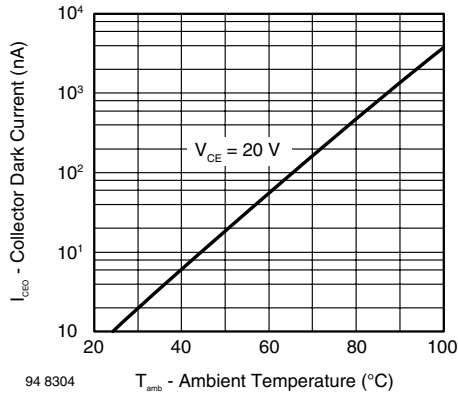
**BASIC CHARACTERISTICS**
 $T_{amb} = 25\text{ }^{\circ}\text{C}$ , unless otherwise specified


Fig. 2 - Collector Dark Current vs. Ambient Temperature

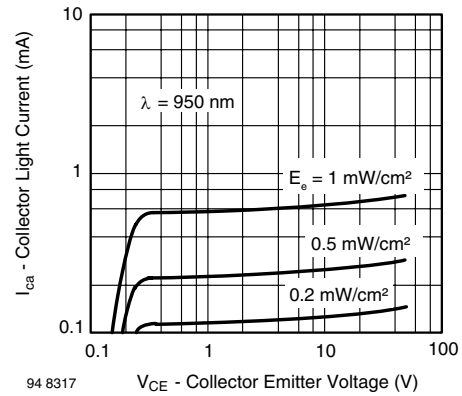


Fig. 5 - Collector Light Current vs. Collector Emitter Voltage

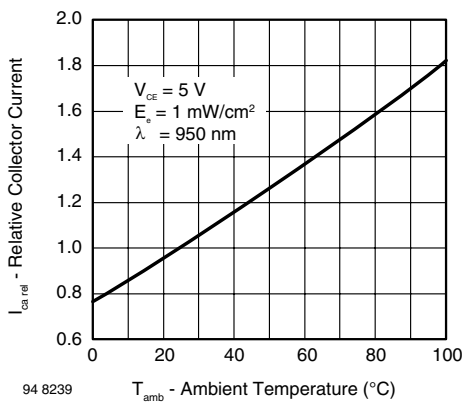


Fig. 3 - Relative Collector Current vs. Ambient Temperature

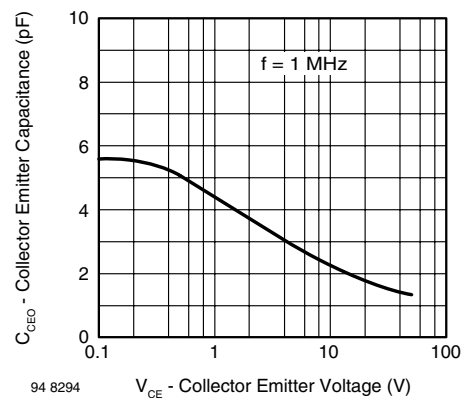


Fig. 6 - Collector Emitter Capacitance vs. Collector Emitter Voltage

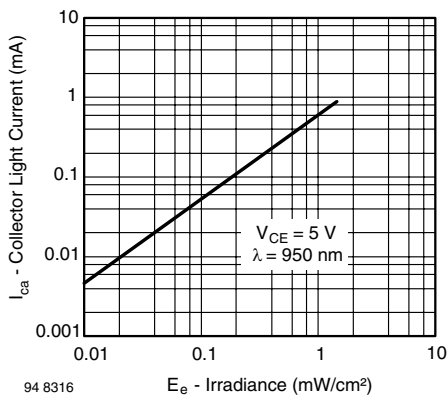


Fig. 4 - Collector Light Current vs. Irradiance

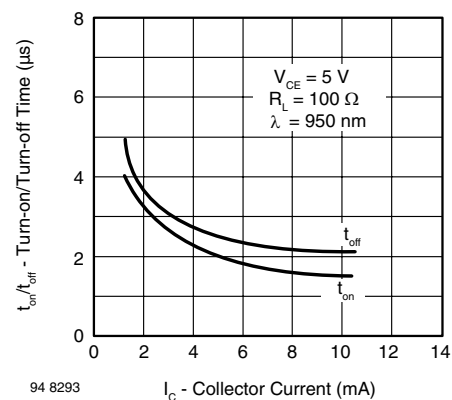


Fig. 7 - Turn-on/Turn-off Time vs. Collector Current

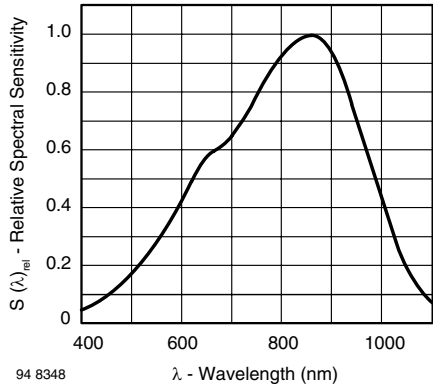


Fig. 8 - Relative Spectral Sensitivity vs. Wavelength

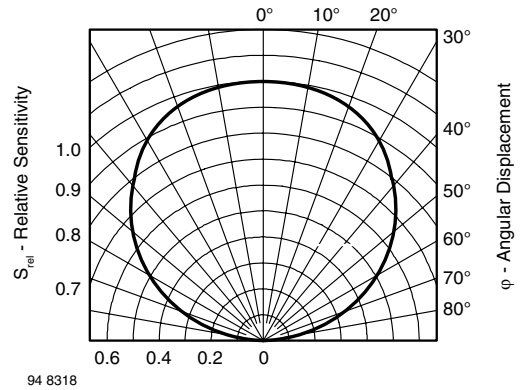
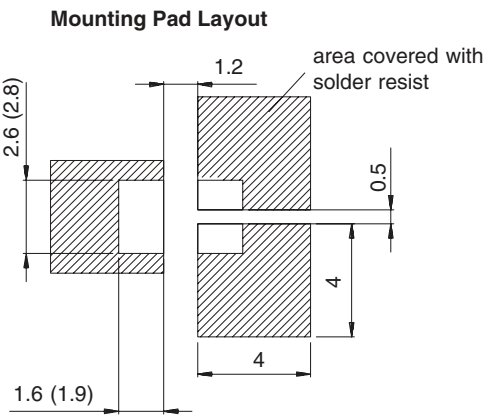
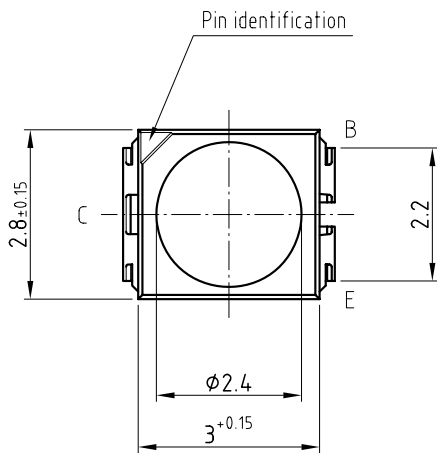
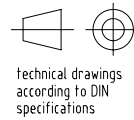
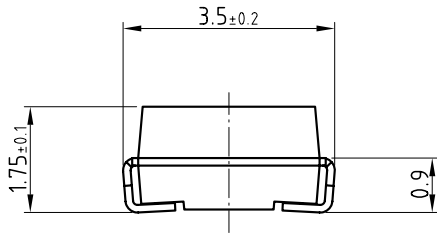


Fig. 9 - Relative Radiant Sensitivity vs. Angular Displacement

## PACKAGE DIMENSIONS in millimeters

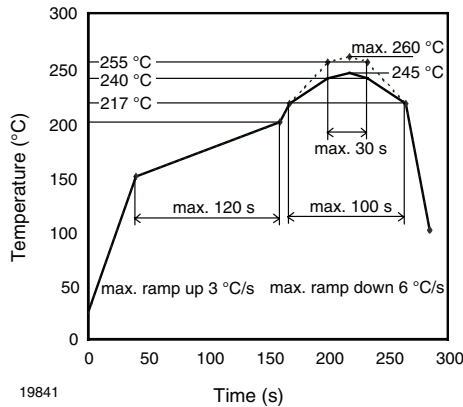


Dimensions: IR and vaporphase (wave soldering)

Drawing-No.: 6.541-5070.01-4

Issue: 1; 30.05.07

21439

**SOLDER PROFILE**

 Fig. 10 - Lead (Pb)-free Reflow Solder Profile  
acc. J-STD-020D

**DRYPACK**

Devices are packed in moisture barrier bags (MBB) to prevent the products from moisture absorption during transportation and storage. Each bag contains a desiccant.

**FLOOR LIFE**

Floor life (time between soldering and removing from MBB) must not exceed the time indicated on MBB label:

Floor life: 4 weeks

Conditions:  $T_{amb} < 30\text{ }^{\circ}\text{C}$ , RH < 60 %

Moisture sensitivity level 2a, acc. to J-STD-020.

**DRYING**

In case of moisture absorption devices should be baked before soldering. Conditions see J-STD-020 or label. Devices taped on reel dry using recommended conditions 192 h at 40 °C (+ 5 °C), RH < 5 %.

**TAPE AND REEL**

PLCC-3 components are packed in antistatic blister tape (DIN IEC (CO) 564) for automatic component insertion. Cavities of blister tape are covered with adhesive tape.

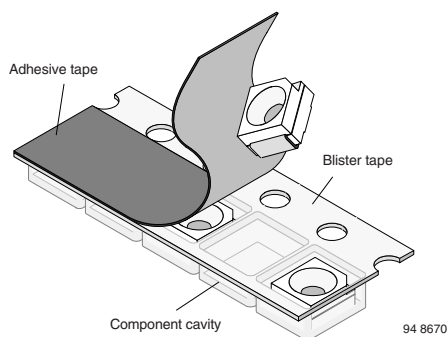


Fig. 11 - Blister Tape

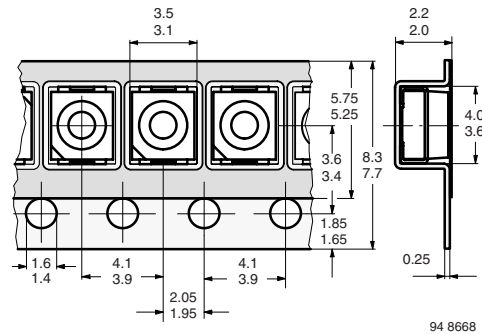


Fig. 12 - Tape Dimensions in mm for PLCC-3

**MISSING DEVICES**

A maximum of 0.5 % of the total number of components per reel may be missing, exclusively missing components at the beginning and at the end of the reel. A maximum of three consecutive components may be missing, provided this gap is followed by six consecutive components.

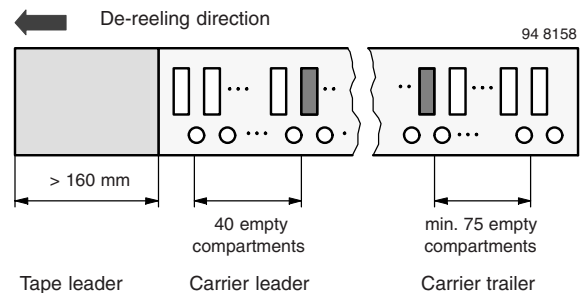


Fig. 13 - Beginning and End of Reel

The tape leader is at least 160 mm and is followed by a carrier tape leader with at least 40 empty compartments. The tape leader may include the carrier tape as long as the cover tape is not connected to the carrier tape. The least component is followed by a carrier tape trailer with at least 75 empty compartments and sealed with cover tape.

## COVER TAPE REMOVAL FORCE

The removal force lies between 0.1 N and 1.0 N at a removal speed of 5 mm/s. In order to prevent components from popping out of the blisters, the cover tape must be pulled off at an angle of 180° with regard to the feed direction.

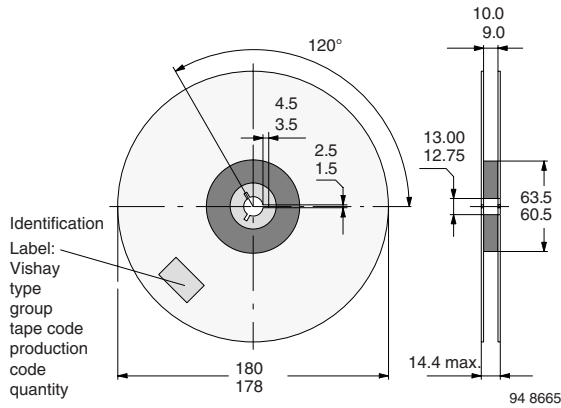


Fig. 14 - Dimensions of Reel-GS08

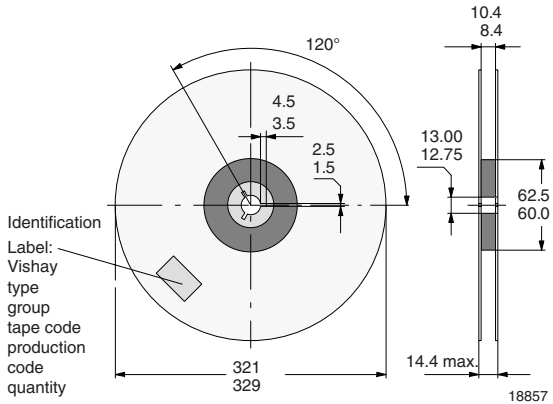


Fig. 15 - Dimensions of Reel-GS18



## Disclaimer

All product specifications and data are subject to change without notice.

Vishay Intertechnology, Inc., its affiliates, agents, and employees, and all persons acting on its or their behalf (collectively, "Vishay"), disclaim any and all liability for any errors, inaccuracies or incompleteness contained herein or in any other disclosure relating to any product.

Vishay disclaims any and all liability arising out of the use or application of any product described herein or of any information provided herein to the maximum extent permitted by law. The product specifications do not expand or otherwise modify Vishay's terms and conditions of purchase, including but not limited to the warranty expressed therein, which apply to these products.

No license, express or implied, by estoppel or otherwise, to any intellectual property rights is granted by this document or by any conduct of Vishay.

The products shown herein are not designed for use in medical, life-saving, or life-sustaining applications unless otherwise expressly indicated. Customers using or selling Vishay products not expressly indicated for use in such applications do so entirely at their own risk and agree to fully indemnify Vishay for any damages arising or resulting from such use or sale. Please contact authorized Vishay personnel to obtain written terms and conditions regarding products designed for such applications.

Product names and markings noted herein may be trademarks of their respective owners.

Компания «Океан Электроники» предлагает заключение долгосрочных отношений при поставках импортных электронных компонентов на взаимовыгодных условиях!

Наши преимущества:

- Поставка оригинальных импортных электронных компонентов напрямую с производств Америки, Европы и Азии, а так же с крупнейших складов мира;
- Широкая линейка поставок активных и пассивных импортных электронных компонентов (более 30 млн. наименований);
- Поставка сложных, дефицитных, либо снятых с производства позиций;
- Оперативные сроки поставки под заказ (от 5 рабочих дней);
- Экспресс доставка в любую точку России;
- Помощь Конструкторского Отдела и консультации квалифицированных инженеров;
- Техническая поддержка проекта, помощь в подборе аналогов, поставка прототипов;
- Поставка электронных компонентов под контролем ВП;
- Система менеджмента качества сертифицирована по Международному стандарту ISO 9001;
- При необходимости вся продукция военного и аэрокосмического назначения проходит испытания и сертификацию в лаборатории (по согласованию с заказчиком);
- Поставка специализированных компонентов военного и аэрокосмического уровня качества (Xilinx, Altera, Analog Devices, Intersil, Interpoint, Microsemi, Actel, Aeroflex, Peregrine, VPT, Syfer, Eurofarad, Texas Instruments, MS Kennedy, Miteq, Cobham, E2V, MA-COM, Hittite, Mini-Circuits, General Dynamics и др.);

Компания «Океан Электроники» является официальным дистрибьютором и эксклюзивным представителем в России одного из крупнейших производителей разъемов военного и аэрокосмического назначения «**JONHON**», а так же официальным дистрибьютором и эксклюзивным представителем в России производителя высокотехнологичных и надежных решений для передачи СВЧ сигналов «**FORSTAR**».



## JONHON

«**JONHON**» (основан в 1970 г.)

Разъемы специального, военного и аэрокосмического назначения:

(Применяются в военной, авиационной, аэрокосмической, морской, железнодорожной, горно- и нефтедобывающей отраслях промышленности)

«**FORSTAR**» (основан в 1998 г.)

ВЧ соединители, коаксиальные кабели,  
кабельные сборки и микроволновые компоненты:

(Применяются в телекоммуникациях гражданского и специального назначения, в средствах связи, РЛС, а так же военной, авиационной и аэрокосмической отраслях промышленности).



Телефон: 8 (812) 309-75-97 (многоканальный)

Факс: 8 (812) 320-03-32

Электронная почта: [ocean@oceanchips.ru](mailto:ocean@oceanchips.ru)

Web: <http://oceanchips.ru/>

Адрес: 198099, г. Санкт-Петербург, ул. Калинина, д. 2, корп. 4, лит. А