

## 1. INTRODUCTION

This Instruction Sheet covers the installation of the 7000 and 7100 Series DIP Programming Switches shown in Figures 1 and 2. Read this document before performing any application using these products.

### NOTE

All dimensions are in metric units [with inches in brackets]. Figures and illustrations are for reference only, and are not drawn to scale.

Reason for revision may be found in Section 5, REVISION SUMMARY.

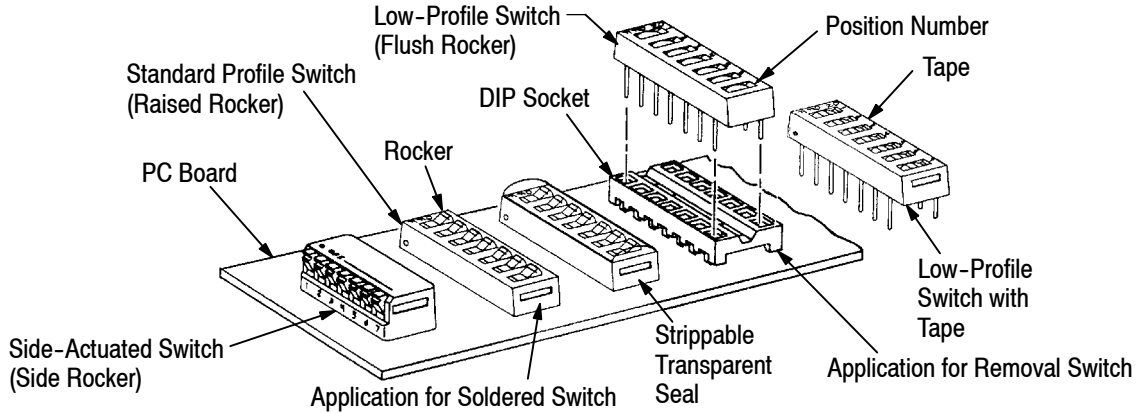

### SINGLE POLE SINGLE THROW (SPST)

SERIES AND COLOR	NUMBER OF POSITIONS	RAISED ROCKER (STANDARD-PROFILE)		SIDE ROCKER (SIDE-ACTUATED)		FLUSH ROCKER (LOW-PROFILE)	
		Unsealed	Econ. Seal	Unsealed	Econ. Seal	Unsealed	Econ. Seal
7000 Black (Refer to Product Spec 108-7519)	2	2-435166-9	---	1-435802-0	---	---	3-435626-6
	3	3-435166-0	---	435802-2	---	---	3-435626-7
	4	435166-2	4-435166-9	435802-3	1-435802-5	435626-1	3-435626-8
	5	435166-3	5-435166-0	435802-4	1-435802-6	435626-2	3-435626-9
	6	435166-4	5-435166-1	435802-5	1-435802-7	---	4-435626-0
	7	435166-1	5-435166-2	435802-6	1-435802-8	---	4-435626-1
	8	435166-5	5-435166-3	435802-1	435802-9	435626-5	4-435626-2
	9	435166-6	5-435166-4	435802-7	1-435802-9	---	4-435626-3
	10	435166-7	5-435166-5	435802-8	2-435802-0	---	4-435626-4
	11	---	---	---	2-435802-1	---	---
	12	3-435166-2	5-435166-7	1-435802-2	2-435802-2	---	4-435626-6
	7100 Blue (Refer to Product Spec 108-7532)	2	2-435640-9	---	---	---	435668-1
3		3-435640-0	---	---	---	435668-2	3-435668-3
4		435640-2	3-435640-5	---	---	435668-3	3-435668-4
5		435640-3	3-435640-6	---	---	435668-4	3-435668-5
6		435640-4	3-435640-7	---	---	435668-5	2-435668-5
7		435640-1	3-435640-8	---	---	435668-6	2-435668-7
8		435640-5	3-435640-9	---	---	435668-7	2-435668-8
9		435640-6	4-435640-0	---	---	---	2-435668-9
10		435640-7	4-435640-1	---	---	435668-9	3-435668-0
11		---	---	---	---	---	3-435668-1
12		3-435640-2	4-435640-3	---	---	1-435668-1	3-435668-2

NOTE: Contact TE Connectivity for RoHS compliant part numbers which may be associated with this document.

Figure 1

## 2. INTRODUCTION

The SPST and MPMT switches are available in 2 through 12 positions. They can be used in DIP sockets with in-row contact centerline spacing of 25.4 [.100] and row-to-row contact centerline spacing of 7.62 [.300], or they can be soldered directly to the printed circuit (pc) board.

There are standard-profile, side-actuated, and low-profile SPST switches. The standard-profile switches have raised rockers, and are available unsealed, or sealed with an economy or premium masking material. The side-actuated switches have rockers on the side rather than on the top, and are available unsealed, or sealed with an economy or premium masking material. The low-profile switches have flush rockers, and are available unsealed, or sealed with an economy clear tape, or sealed with a premium masking material.

There are standard-profile and side-actuated MPMT switches. The standard-profile MPMT comes in both Single-Pole Double-Throw (SPDT) and Double-Pole Double-Throw (DPDT) make-before-break switches and are available with a low-profile and extended lever actuator. The side-actuated MPMT is available in SPST only at this time. All of these switches are available in the unsealed version only.

The unsealed switches are designed for socket applications and the sealed are designed for soldering applications directly to the pc board. The sealants prevent flux and other contaminants from entering the switch during soldering and cleaning.

## 3. SWITCH INSTALLATION

Determine the number of switch positions required for your application. Determine whether the switch will be soldered directly to the pc board ( a sealed switch will be required), or whether the switch is to be installed in a socket (an unsealed switch can be used). Refer to the tables in Figures 1 or 2 for assistance in selecting a switch.

### 3.1. DIP Socket Installation

1. Secure DIP socket to pc board according to instructions packaged with socket.
2. Start one row of contact leads into one row of contact cavities in socket, then rotate switch until it is parallel with socket.
3. Gripping ends of switch, push switch into socket until it is bottomed
4. Determine which of the circuits are to be closed, then depress the applicable rockers to the ON position.
5. If installing a protective dust cover, determine the number of switch positions and refer to Customer Drawing 435238 to select the applicable cover. Check to be sure there are no obstructions on the switch rockers or in the protective cover, then slide the cover over the rockers until the cover latches engage the housing. See Figure 3.

**MULTIPLE THROW MULTIPLE THROW SWITCHES (MPMT)**

SERIES AND COLOR	NUMBER OF SWITCHES	DOUBLE POLE SINGLE THROW		SINGLE POLE DOUBLE THROW	
		Low Profile Actuator	Extended Actuator	Low Profile Actuator	Extended Actuator
7000 Black (Refer to Product Spec 108-7519)	1	435469-9	2-435469-1	435470-7	2-435470-1
	2	---	2-435469-2	435470-1	2-435470-2
	3	435469-2	2-435469-3	435470-2	---
	4	435469-3	2-435469-4	435470-3	2-435470-4
	5	---	2-435469-5	435470-4	2-435470-5
	6	1-435469-0	2-435469-6	435470-8	2-435470-6

SERIES AND COLOR	NUMBER OF SWITCHES	FOUR POLE SINGLE THROW		DOUBLE POLE DOUBLE THROW	
		Low Profile Actuator	Extended Actuator	Low Profile Actuator	Extended Actuator
7000 Black (Refer to Product Spec 108-7519)	1	435469-7	3-435469-1	435470-5	3-435470-1
	2	---	3-435469-2	435470-9	3-435470-2
	3	---	---	---	3-435470-3

Figure 2

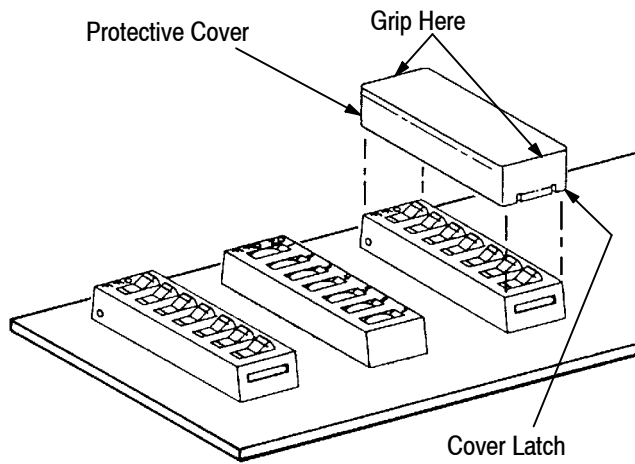

Figure 3

### 3.2. PC Board Installation

1. Make a layout on the pc board according to the dimensions shown in Figure 4.
2. Make certain all contact leads have started entry into holes. Grip sides of switch and push switch into pc board until it is bottomed.
3. Hold switch at a slight angle and start one row on contact leads into pc board holes. Do NOT over-insert. Switch should be rotated until second row of contact leads are aligned with opposite row of contact holes.

Use Light Pressure to Insert Switch

Rotate to Align Second Row - Then Push Down on Ends of Switch

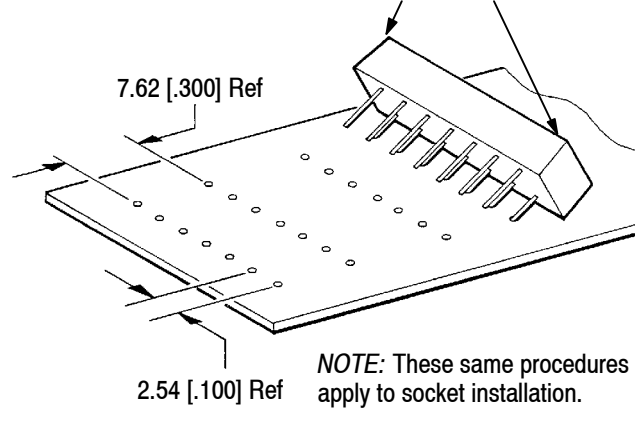

Figure 4

**NOTE** To hold switch in place during wave soldering, the four outside contact leads may be clinched inward at 45°. Refer to Figure 5.

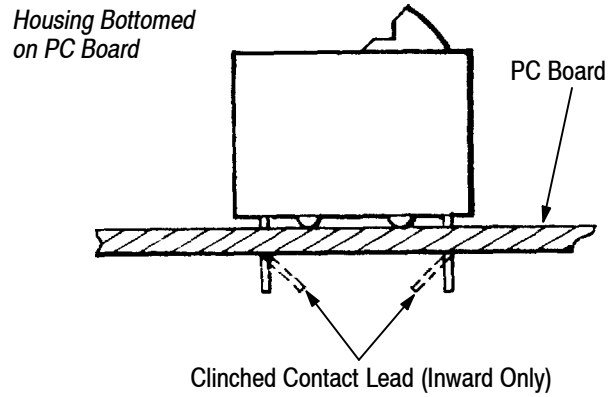

Figure 5

**NOTE** For pc board soldering and cleaning procedures, and recommended solvents, refer to Application Specification 114-1056.

### 4. SWITCH PROGRAMMING

After the switch has been inserted into the DIP socket or soldered onto the pc board, proceed as follows:

1. Remove seal from the switches, see Figure 6.

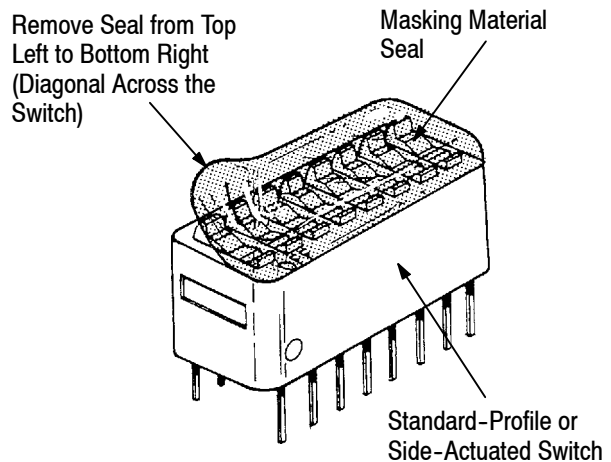
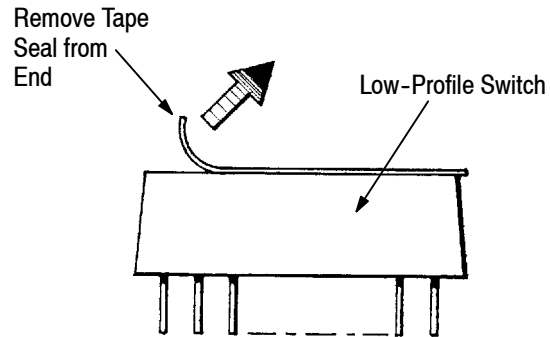

Figure 6

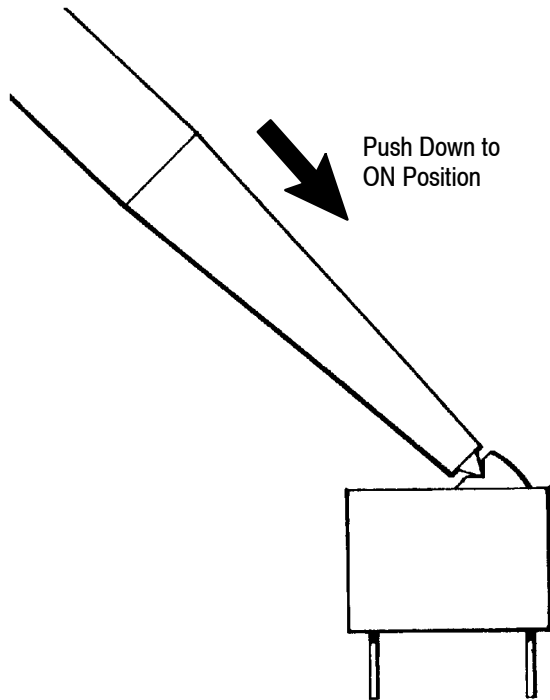

Figure 7

2. Determine which circuits are to be closed, then depress applicable rockers to ON position. Refer to Figure 7.

#### 5. REVISION SUMMARY

- Updated document to corporate requirements
- New logo

Компания «Океан Электроники» предлагает заключение долгосрочных отношений при поставках импортных электронных компонентов на взаимовыгодных условиях!

Наши преимущества:

- Поставка оригинальных импортных электронных компонентов напрямую с производств Америки, Европы и Азии, а так же с крупнейших складов мира;
- Широкая линейка поставок активных и пассивных импортных электронных компонентов (более 30 млн. наименований);
- Поставка сложных, дефицитных, либо снятых с производства позиций;
- Оперативные сроки поставки под заказ (от 5 рабочих дней);
- Экспресс доставка в любую точку России;
- Помощь Конструкторского Отдела и консультации квалифицированных инженеров;
- Техническая поддержка проекта, помощь в подборе аналогов, поставка прототипов;
- Поставка электронных компонентов под контролем ВП;
- Система менеджмента качества сертифицирована по Международному стандарту ISO 9001;
- При необходимости вся продукция военного и аэрокосмического назначения проходит испытания и сертификацию в лаборатории (по согласованию с заказчиком);
- Поставка специализированных компонентов военного и аэрокосмического уровня качества (Xilinx, Altera, Analog Devices, Intersil, Interpoint, Microsemi, Actel, Aeroflex, Peregrine, VPT, Syfer, Eurofarad, Texas Instruments, MS Kennedy, Miteq, Cobham, E2V, MA-COM, Hittite, Mini-Circuits, General Dynamics и др.);

Компания «Океан Электроники» является официальным дистрибьютором и эксклюзивным представителем в России одного из крупнейших производителей разъемов военного и аэрокосмического назначения «JONHON», а так же официальным дистрибьютором и эксклюзивным представителем в России производителя высокотехнологичных и надежных решений для передачи СВЧ сигналов «FORSTAR».



## JONHON

«JONHON» (основан в 1970 г.)

Разъемы специального, военного и аэрокосмического назначения:

(Применяются в военной, авиационной, аэрокосмической, морской, железнодорожной, горно- и нефтедобывающей отраслях промышленности)

«FORSTAR» (основан в 1998 г.)

ВЧ соединители, коаксиальные кабели,  
кабельные сборки и микроволновые компоненты:

(Применяются в телекоммуникациях гражданского и специального назначения, в средствах связи, РЛС, а так же военной, авиационной и аэрокосмической отраслях промышленности).



Телефон: 8 (812) 309-75-97 (многоканальный)

Факс: 8 (812) 320-03-32

Электронная почта: [ocean@oceanchips.ru](mailto:ocean@oceanchips.ru)

Web: <http://oceanchips.ru/>

Адрес: 198099, г. Санкт-Петербург, ул. Калинина, д. 2, корп. 4, лит. А