

**HIGH VOLTAGE FAST SWITCHING NPN POWER TRANSISTOR      APT13003D****General Description**

The APT13003D is a high voltage, high speed, high efficiency switching transistor, and it is specially designed for off-line switch mode power supplies with low output power.

The APT13003D is available in TO-92 (bulk or ammo packing), TO-126 and TO-251 packages.

**Features**

- High Switching Speed
- High Collector-Emitter Voltage: 700V
- Low Cost
- High Efficiency

**Applications**

- Battery Chargers for Mobile Phone of BCD Solution
- Power Supply for DVD/STB of BCD Solution

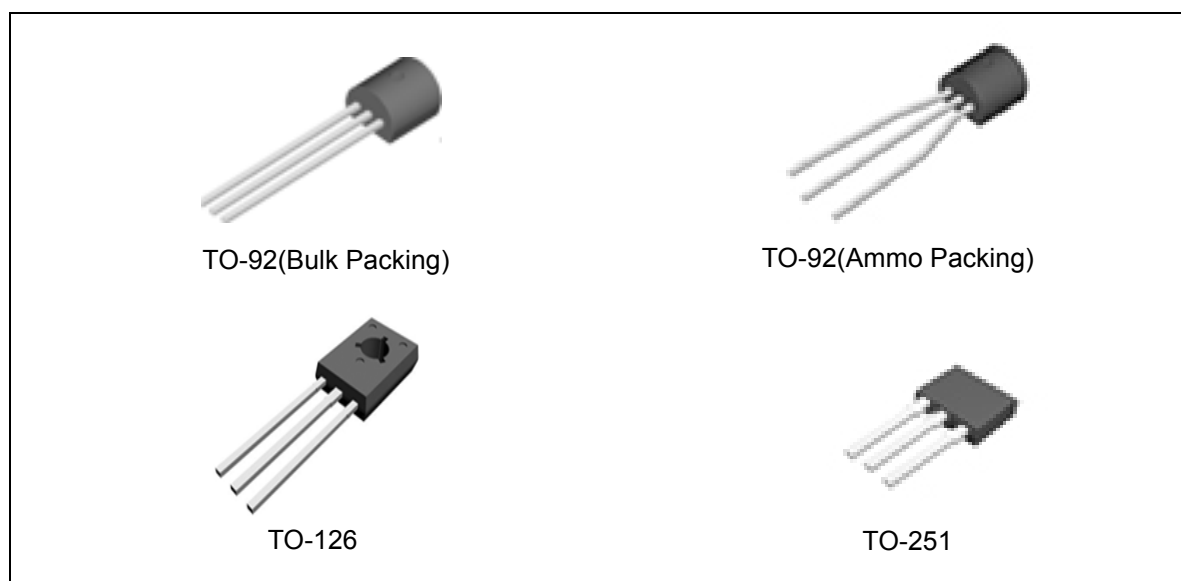

Figure 1. Package Types of APT13003D

**HIGH VOLTAGE FAST SWITCHING NPN POWER TRANSISTOR      APT13003D**

**Pin Configuration**

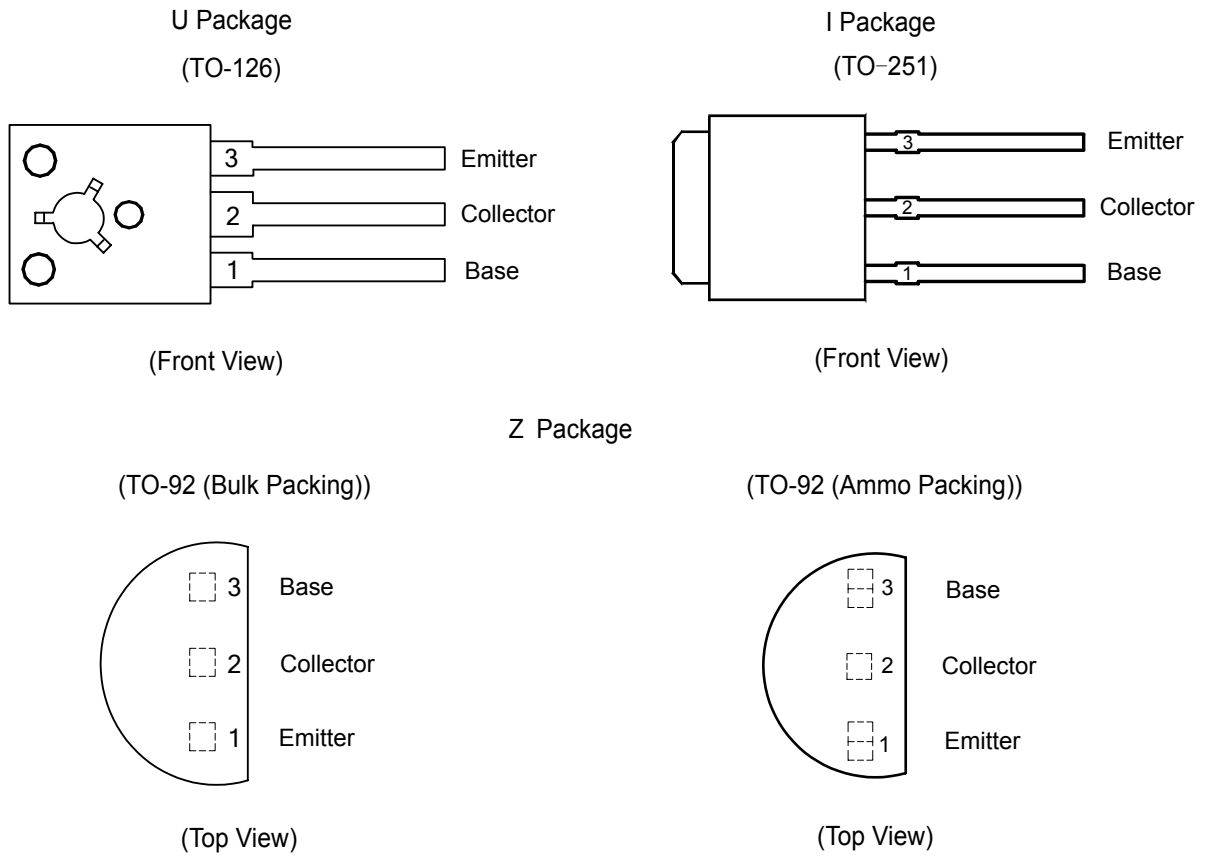

Figure 2. Pin Configuration of APT13003D

**Internal Structure**

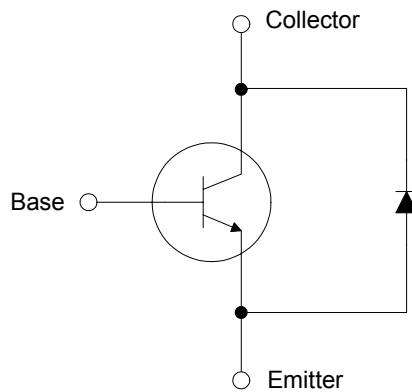
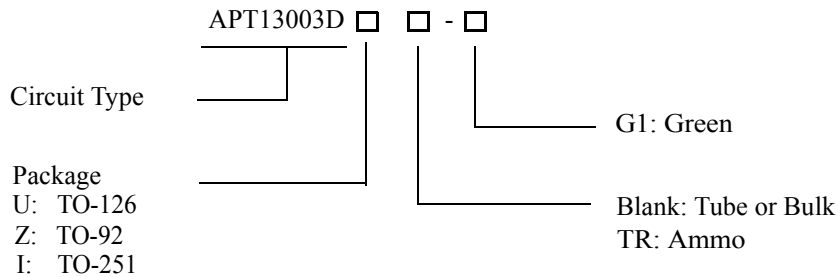

Figure 3. Internal Structure of APT13003D



**HIGH VOLTAGE FAST SWITCHING NPN POWER TRANSISTOR      APT13003D**

**Ordering Information**



Package	Part Number	Marking ID	Packing Type
TO-126	APT13003DU-G1	GU13003D	Bulk
TO-92	APT13003DZ-G1	13003DZ-G1	Bulk
	APT13003DZTR-G1	13003DZ-G1	Ammo
TO-251	APT13003DI-G1	APT13003DI-G1	Tube

BCD Semiconductor's Pb-free products, as designated with "G1" suffix in the part number, are RoHS compliant and green.

**Absolute Maximum Ratings (Note 1)**

Parameter	Symbol	Value	Unit
Collector-Emitter Voltage ( $V_{BE}=0$ )	$V_{CES}$	700	V
Collector-Emitter Voltage ( $I_B=0$ )	$V_{CEO(sus)}$	450	V
Emitter-Base Breakdown Voltage ( $I_C=0$ )	$V_{EBO}$	9	V
Collector Current	$I_C$	1.5	A
Collector Peak Current	$I_{CM}$	3.0	A
Base Current	$I_B$	0.75	A
Base Peak Current	$I_{BM}$	1.5	A
Power Dissipation ( $T_A=25^{\circ}C$ )	For TO-92	1.1	W
	For TO-251	24	
	For TO-126	20	
Operating Junction Temperature	$T_J$	150	$^{\circ}C$
Storage Temperature Range	$T_{STG}$	-55 to 150	$^{\circ}C$

Note 1: Stresses greater than those listed under "Absolute Maximum Ratings" may cause permanent damage to the device. These are stress ratings only, and functional operation of the device at these or any other conditions beyond those indicated under "Recommended Operating Conditions" is not implied. Exposure to "Absolute Maximum Ratings" for extended periods may affect device reliability.

**HIGH VOLTAGE FAST SWITCHING NPN POWER TRANSISTOR     APT13003D****Thermal Characteristics**

Parameter		Symbol	Value	Unit
Maximum Thermal Resistance (Junction to Case)	For TO-126	$\theta_{JC}$	6.25	°C/W
	For TO-251		5.0	
	For TO-92		83.3	
Maximum Thermal Resistance (Junction to Ambient)	For TO-126	$\theta_{JA}$	96	°C/W
	For TO-251		110	
	For TO-92		113.6	

**Electrical Characteristics**(  $T_C=25^\circ\text{C}$ , unless otherwise specified.)

Parameter	Symbol	Condition	Min	Typ	Max	Unit
Collector Cut-off Current ( $V_{BE}=-1.5\text{V}$ )	$I_{CEV}$	$V_{CE}=700\text{V}$			10	$\mu\text{A}$
Collector-Emitter Sustaining ( $I_B=0$ )	$V_{CEO}(\text{sus})$	$I_C=100\mu\text{A}$	450			V
Collector-Emitter Saturation Voltage	$V_{CE}(\text{sat})$	$I_C=0.5\text{A}, I_B=0.1\text{A}$			0.3	V
		$I_C=1.0\text{A}, I_B=0.25\text{A}$			0.4	
Base-Emitter Saturation Voltage	$V_{BE}(\text{sat})$	$I_C=0.5\text{A}, I_B=0.1\text{A}$			1.0	V
		$I_C=1.0\text{A}, I_B=0.25\text{A}$			1.2	
DC Current Gain (Note 2)	$h_{FE}$	$I_C=0.5\text{A}, V_{CE}=2.0\text{V}$	16		30	
		$I_C=1.0\text{A}, V_{CE}=2.0\text{V}$	5.0		25	
Turn-on Time with Resistive Load	$t_{on}$	$I_C=1.0\text{A}, V_{CC}=125\text{V}$ $I_{B1}=0.2\text{A}, I_{B2}=-0.2\text{A}$			0.7	$\mu\text{s}$
Storage Time with Resistive Load	$t_s$				3.0	$\mu\text{s}$
Fall Time with Resistive Load	$t_f$				0.35	$\mu\text{s}$
Output Capacitance	$C_{OB}$	$V_{CB}=10\text{V}, f=0.1\text{MHz}$		18		pF
Current Gain Bandwidth Product	$f_T$	$V_{CE}=10\text{V}, I_C=0.1\text{A}$	4			MH

Note 2: Pulse test for Pulse Width  $\leq 300\mu\text{s}$ , Duty Cycle  $\leq 2\%$ .



**HIGH VOLTAGE FAST SWITCHING NPN POWER TRANSISTOR     APT13003D**

**Typical Performance Characteristics**

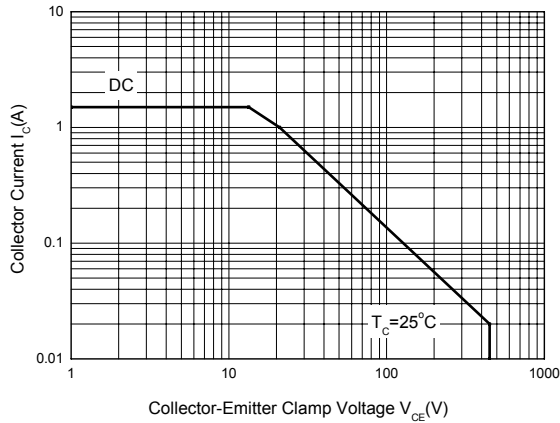

Figure 4. Safe Operating Areas (TO-126 Package)

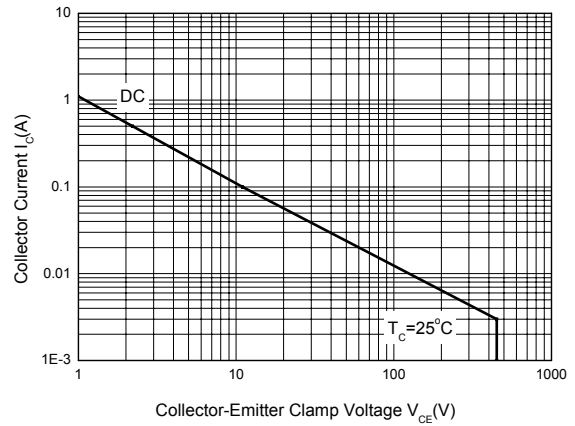

Figure 5. Safe Operating Areas (TO-92 Package)

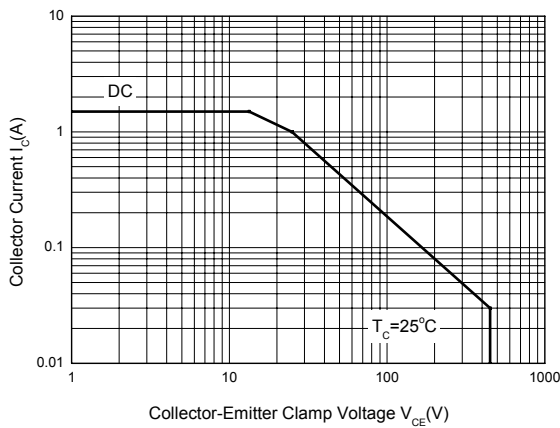

Figure 6. Safe Operating Areas (TO-251 Package)

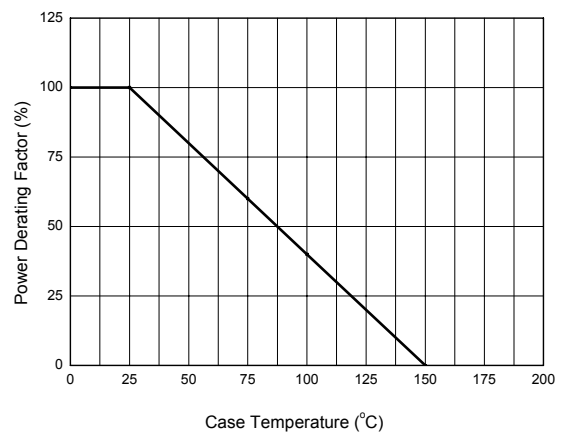

Figure 7. Power Derating Curve



**HIGH VOLTAGE FAST SWITCHING NPN POWER TRANSISTOR     APT13003D**

**Typical Performance Characteristics (Continued)**

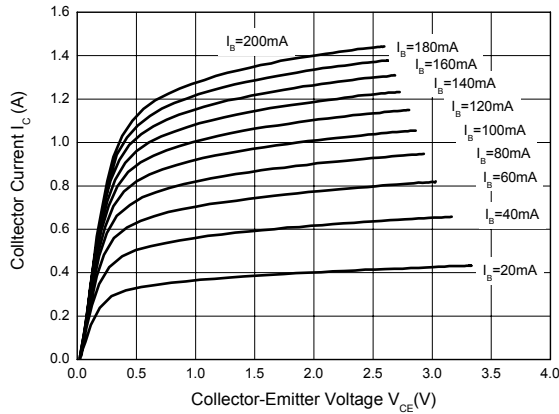

Figure 8. Static Characteristics

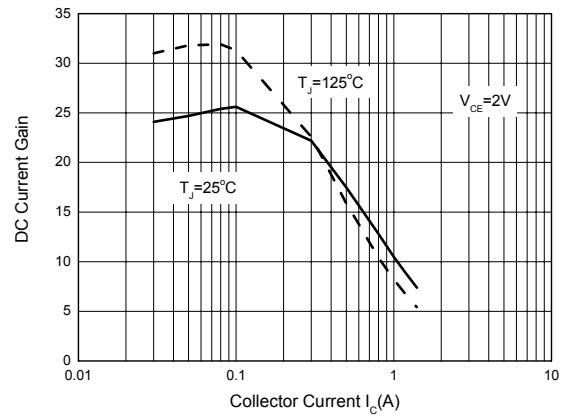

Figure 9. DC Current Gain

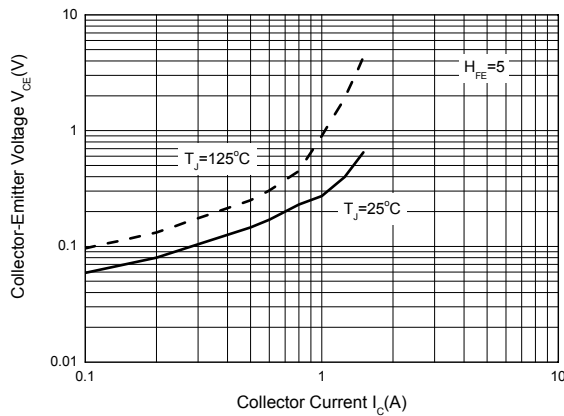

Figure 10. Collector-Emmitter Saturation Region

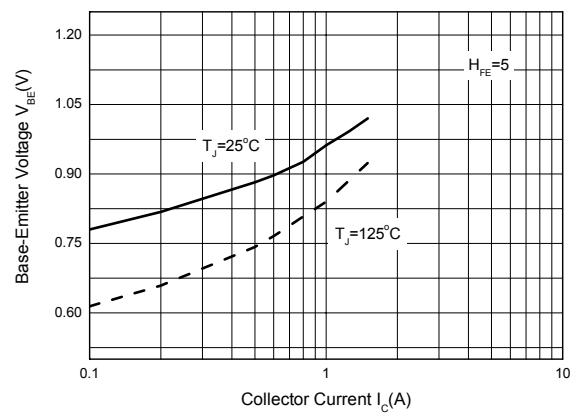

Figure 11. Base-Emmitter Saturation Voltage

**HIGH VOLTAGE FAST SWITCHING NPN POWER TRANSISTOR APT13003D**

**Mechanical Dimensions**

**TO-18**

**Unit: mm(inch)**

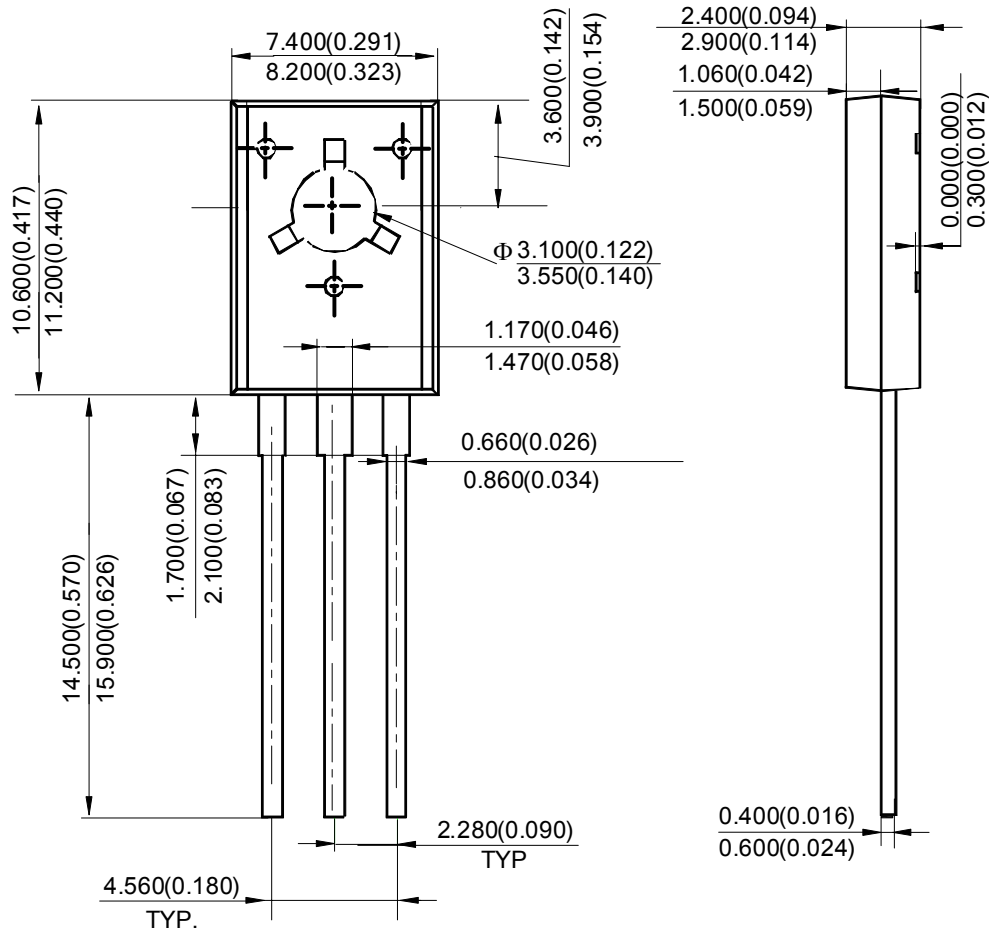



**HIGH VOLTAGE FAST SWITCHING NPN POWER TRANSISTOR      APT13003D**

**Mechanical Dimensions (Continued)**

**TO-92 (Bulk Packing)**

**Unit: mm(inch)**

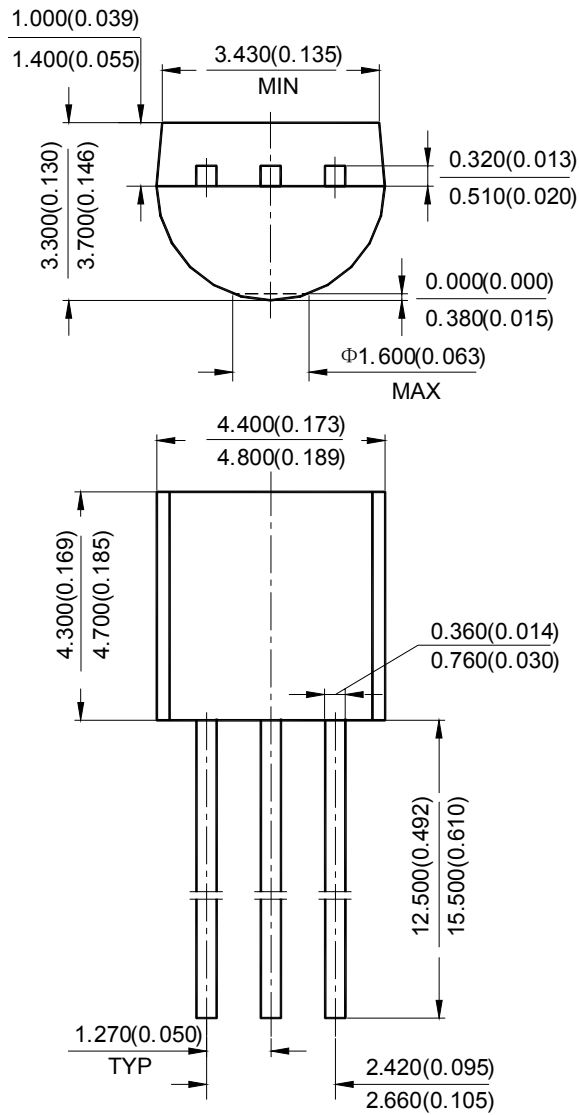





**HIGH VOLTAGE FAST SWITCHING NPN POWER TRANSISTOR      APT13003D**

**Mechanical Dimensions (Continued)**

**TO-92 ( Ammo Packing)**

**Unit: mm(inch)**

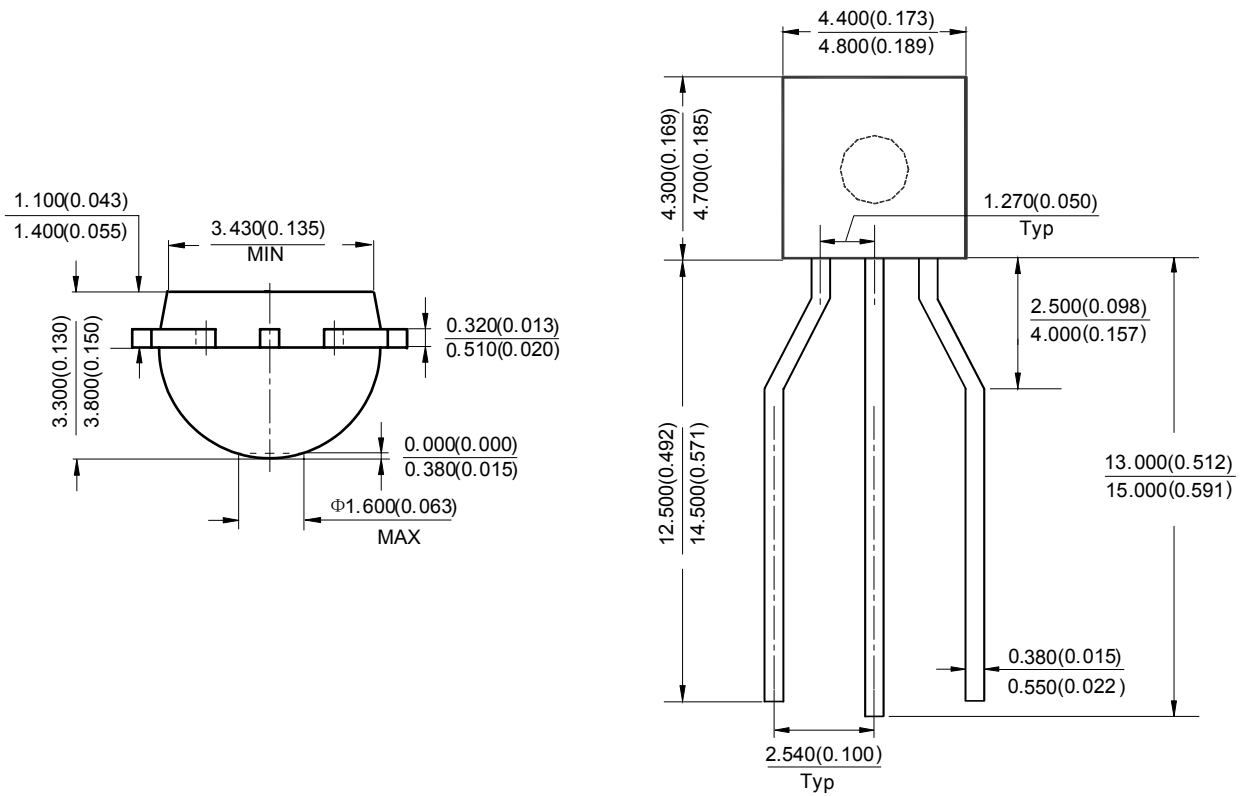



**HIGH VOLTAGE FAST SWITCHING NPN POWER TRANSISTOR      APT13003D**

**Mechanical Dimensions (Continued)**

**TO-251**

**Unit: mm(inch)**

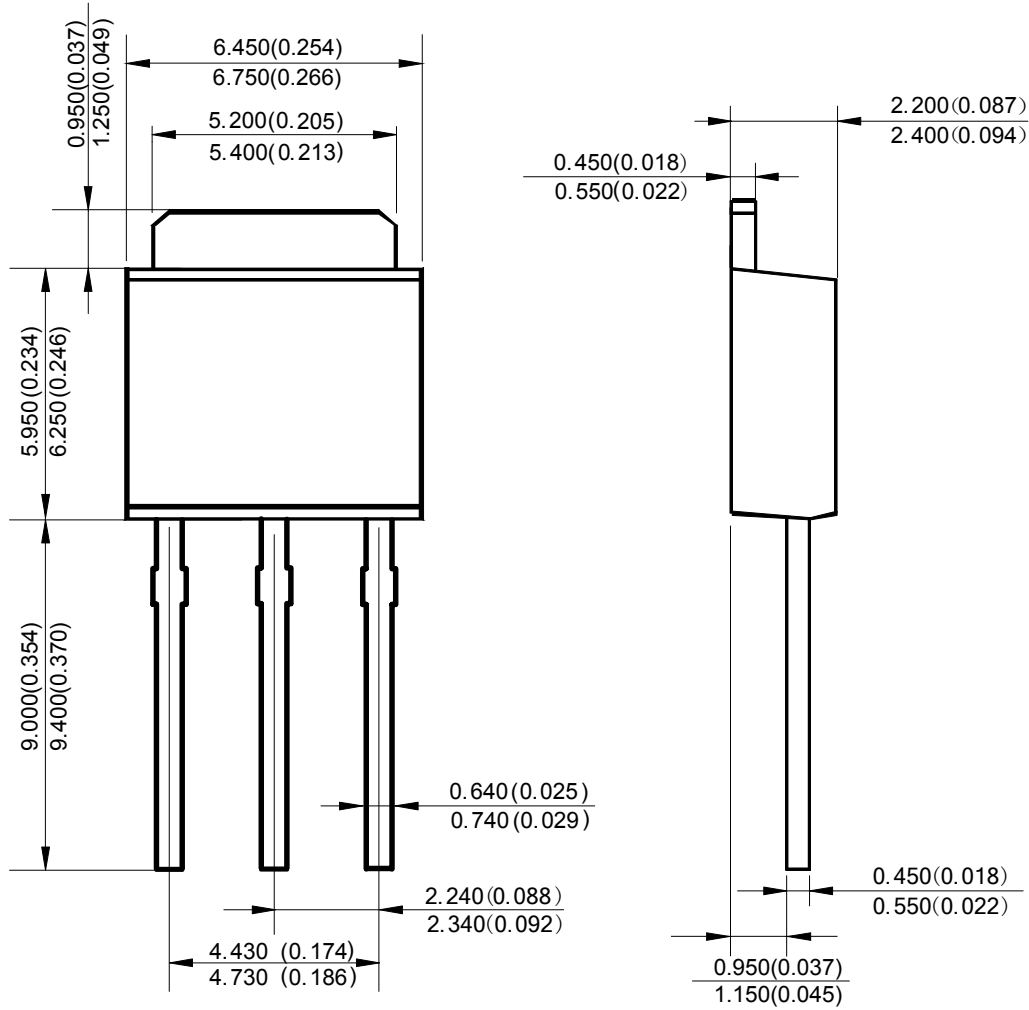



## **BCD Semiconductor Manufacturing Limited**

<http://www.bcdsemi.com>

### **IMPORTANT NOTICE**

BCD Semiconductor Manufacturing Limited reserves the right to make changes without further notice to any products or specifications herein. BCD Semiconductor Manufacturing Limited does not assume any responsibility for use of any its products for any particular purpose, nor does BCD Semiconductor Manufacturing Limited assume any liability arising out of the application or use of any its products or circuits. BCD Semiconductor Manufacturing Limited does not convey any license under its patent rights or other rights nor the rights of others.

---

#### **MAIN SITE**

##### **- Headquarters**

##### **BCD Semiconductor Manufacturing Limited**

No. 1600, Zi Xing Road, Shanghai Zizhu Science-based Industrial Park, 200241, China  
Tel: +86-21-24162266, Fax: +86-21-24162277

##### **- Wafer Fab**

##### **Shanghai SIM-BCD Semiconductor Manufacturing Co., Ltd.**

800 Yi Shan Road, Shanghai 200233, China  
Tel: +86-21-6485 1491, Fax: +86-21-5450 0008

#### **REGIONAL SALES OFFICE**

##### **Shenzhen Office**

##### **Shanghai SIM-BCD Semiconductor Manufacturing Co., Ltd., Shenzhen Office**

Unit A Room 1203, Skyworth Bldg., Gaoxin Ave. 1.S., Nanshan District, Shenzhen, China  
Tel: +86-755-8826 7951  
Fax: +86-755-8826 7865

##### **Taiwan Office**

##### **BCD Semiconductor (Taiwan) Company Limited**

4F, 298-1, Rui Guang Road, Nei-Hu District, Taipei, Taiwan  
Tel: +886-2-2656 2808  
Fax: +886-2-2656 2806

##### **USA Office**

##### **BCD Semiconductor Corp.**

30920 Huntwood Ave. Hayward, CA 94544, USA  
Tel : +1-510-324-2988  
Fax: +1-510-324-2788

Компания «Океан Электроники» предлагает заключение долгосрочных отношений при поставках импортных электронных компонентов на взаимовыгодных условиях!

Наши преимущества:

- Поставка оригинальных импортных электронных компонентов напрямую с производств Америки, Европы и Азии, а так же с крупнейших складов мира;
- Широкая линейка поставок активных и пассивных импортных электронных компонентов (более 30 млн. наименований);
- Поставка сложных, дефицитных, либо снятых с производства позиций;
- Оперативные сроки поставки под заказ (от 5 рабочих дней);
- Экспресс доставка в любую точку России;
- Помощь Конструкторского Отдела и консультации квалифицированных инженеров;
- Техническая поддержка проекта, помощь в подборе аналогов, поставка прототипов;
- Поставка электронных компонентов под контролем ВП;
- Система менеджмента качества сертифицирована по Международному стандарту ISO 9001;
- При необходимости вся продукция военного и аэрокосмического назначения проходит испытания и сертификацию в лаборатории (по согласованию с заказчиком);
- Поставка специализированных компонентов военного и аэрокосмического уровня качества (Xilinx, Altera, Analog Devices, Intersil, Interpoint, Microsemi, Actel, Aeroflex, Peregrine, VPT, Syfer, Eurofarad, Texas Instruments, MS Kennedy, Miteq, Cobham, E2V, MA-COM, Hittite, Mini-Circuits, General Dynamics и др.);

Компания «Океан Электроники» является официальным дистрибьютором и эксклюзивным представителем в России одного из крупнейших производителей разъемов военного и аэрокосмического назначения «JONHON», а так же официальным дистрибьютором и эксклюзивным представителем в России производителя высокотехнологичных и надежных решений для передачи СВЧ сигналов «FORSTAR».



## JONHON

«JONHON» (основан в 1970 г.)

Разъемы специального, военного и аэрокосмического назначения:

(Применяются в военной, авиационной, аэрокосмической, морской, железнодорожной, горно- и нефтедобывающей отраслях промышленности)

«FORSTAR» (основан в 1998 г.)

ВЧ соединители, коаксиальные кабели, кабельные сборки и микроволновые компоненты:

(Применяются в телекоммуникациях гражданского и специального назначения, в средствах связи, РЛС, а так же военной, авиационной и аэрокосмической отраслях промышленности).



Телефон: 8 (812) 309-75-97 (многоканальный)

Факс: 8 (812) 320-03-32

Электронная почта: [ocean@oceanchips.ru](mailto:ocean@oceanchips.ru)

Web: <http://oceanchips.ru/>

Адрес: 198099, г. Санкт-Петербург, ул. Калинина, д. 2, корп. 4, лит. А