



MIC33050 Evaluation Board

4MHz Internal Inductor PWM Buck Regulator with HyperLight Load[®]

General Description

The MIC33050 is a 600mA 4MHz switching regulator featuring HyperLight Load[®] mode. The MIC33050 is highly efficient throughout the entire output current range, drawing just 20 μ A of quiescent current in operation. The tiny 3mm x 3mm MLF[®] package, in combination with the 4MHz switching frequency, enables a compact sub-1mm height solution with only three external components. The MIC33050 provides accurate output voltage regulation under the most demanding conditions and responds extremely quickly to a load transient with exceptionally small output voltage ripple.

Factoring in the output current, the internal circuitry of the MIC33050 automatically selects between two modes of operation for optimum efficiency. Under light load conditions, the MIC33050 goes into HyperLight Load mode. HyperLight Load uses a pulse-frequency modulation (PFM) control scheme that controls the off time at light load. This proprietary architecture reduces the amount of switching needed at light load, thereby increasing operating efficiency. The MIC33050 attains up to 83% efficiency at 1mA output load. As the load current increases beyond approximately 100mA, the device operates using the pulse-width modulation (PWM) method for up to 93% efficiency at higher load. The two modes of operation ensure the highest efficiency across the entire load range.

The MIC33050 operates from an input voltage range of 2.7V to 5.5V and features internal power MOSFETs that deliver up to 600mA of output current. This step-down regulator provides an output voltage accuracy of $\pm 2.5\%$ across the junction temperature range of -40°C to $+125^{\circ}\text{C}$. The MIC33050 is available in fixed or adjustable versions supporting an output voltage as low as 0.7V.

Requirements

The MIC33050 evaluation board requires an input power source that is able to deliver greater than 650mA at 2.7V. The output load can either be an active (electronic) or passive (resistive) load.

Getting Started

1. **Connect an external supply to the V_{IN} (J1) terminal.** Apply the desired input voltage to V_{IN} (J1) and ground (J2) terminals of the evaluation board, paying careful attention to polarity and supply voltage ($2.7\text{V} \leq V_{\text{IN}} \leq 5.5\text{V}$). An ammeter may be placed between the input supply and the V_{IN} (J1) terminal. Be sure to monitor the supply voltage at the V_{IN} (J1) terminal, since the ammeter and/or power lead resistance can reduce the voltage supplied to the device.
2. **Connect a load to the V_{OUT} (J3) and ground terminal (J4).** The load can be either passive (resistive) or active (electronic load). An ammeter may be placed between the load and the output terminal. Ensure the output voltage is monitored at the V_{OUT} (J3) terminal.
3. **Enable the MIC33050.** The MIC33050 evaluation board has a pull-up resistor to V_{IN} . To disable the device, apply a voltage below 0.5V to the EN (J5) terminal. In the absence of the pull-up resistor, the device is enabled by applying a voltage greater than 1.2V to the EN (J5) terminal. The enable pin must be either pulled high or low for proper operation. Removing the pull-up resistor and leaving the pin floating will cause the regulator to operate in an unknown state.

Output Voltage

The MIC33050 evaluation board is available with the following output voltage options listed in *Ordering Information*.

Ordering Information

Part Number	Description
MIC33050-CYHL EV	1.0V Fixed Output Evaluation Board
MIC33050-4YHL EV	1.2V Fixed Output Evaluation Board
MIC33050-GYHL EV	1.8V Fixed Output Evaluation Board
MIC33050-SYHL EV	3.3V Fixed Output Evaluation Board
MIC33050-AYHL EV	Adjustable Output Evaluation Board

HyperLight Load is a trademark of Micrel, Inc.
MLF and MicroLeadFrame are registered trademarks of Amkor Technology, Inc.

Micrel Inc. • 2180 Fortune Drive • San Jose, CA 95131 • USA • tel +1 (408) 944-0800 • fax + 1 (408) 474-1000 • <http://www.micrel.com>

Output Voltage (Adjustable Option Only)

The output voltage of the MIC33050-AYHL is set by the feedback resistors R2 and R3. Follow the equation and circuit below to determine V_{OUT} :

$$V_{OUT} = 0.4V \times \left(1 + \frac{R2}{R3} \right) \quad \text{Eq. 1}$$

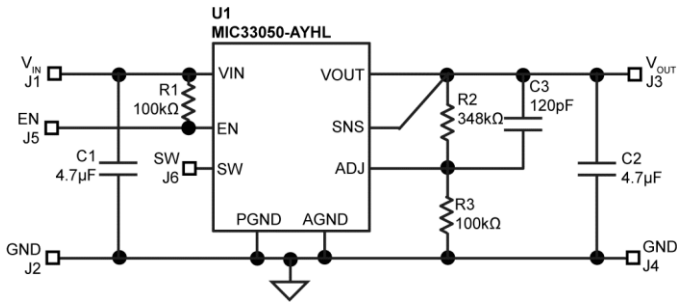

Figure 1. Typical Circuit for MIC33050-AYHL ($V_{OUT} = 1.8V$)

The default output voltage for the evaluation board is set to 1.8V ($R2=348k\Omega$, $R3=100k\Omega$). A different output voltage can be obtained by removing R2 and replacing it with the desired resistance. The equation below can be used to find R2:

$$R2 = R3 \times \left(\frac{V_{OUT}}{0.4V} - 1 \right) \quad \text{Eq. 2}$$

Changing the output voltage to 2.5V, assuming $R3=100k\Omega$, can be accomplished via the equation below:

$$R2 = 100k\Omega \times \left(\frac{2.5V}{0.4V} - 1 \right) \quad \text{Eq. 3}$$

The result is 523kΩ for R2 which gives an output voltage of 2.5V.

HyperLight Load Mode

MIC33050 uses a minimum on and off time proprietary control loop (patented by Micrel). When the output voltage falls below the regulation threshold, the error comparator begins a switching cycle that turns the PMOS on and keeps it on for the duration of the minimum-on-time.

This increases the output voltage. If the output voltage is over the regulation threshold, then the error comparator turns the PMOS off for a minimum-off-time until the output drops below the threshold. The NMOS acts as an ideal rectifier that conducts when the PMOS is off. Using a NMOS switch instead of a diode allows for lower voltage drop across the switching device when it is on. The asynchronous switching combination between the PMOS and the NMOS allows the control loop to work in discontinuous mode for light load operations. In discontinuous mode, the MIC33050 works in pulse frequency modulation (PFM) to regulate the output. As the output current increases, the off-time decreases, thus provides more energy to the output. This switching scheme improves the efficiency of MIC33050 during light load currents by only switching when it is needed. As the load current increases, the MIC33050 goes into continuous conduction mode (CCM) and switches at a frequency centered at 4MHz. The equation to calculate the load when the MIC33050 goes into continuous conduction mode may be approximated by the following formula:

$$I_{LOAD} > \left(\frac{(V_{IN} - V_{OUT}) \times D}{2L \times f} \right) \quad \text{Eq. 4}$$

As shown in the previous equation, the load at which MIC33050 transitions from HyperLight Load mode to PWM mode is a function of the input voltage (V_{IN}), output voltage (V_{OUT}), duty cycle (D), inductance (L) and frequency (f). As shown in Figure 1, as the Output Current increases, the switching frequency also increases until the MIC33050 goes from HyperLight Load mode to PWM mode at approximately 120mA. The MIC33050 will switch at a relatively constant frequency around 4MHz once the output current is over 120mA.

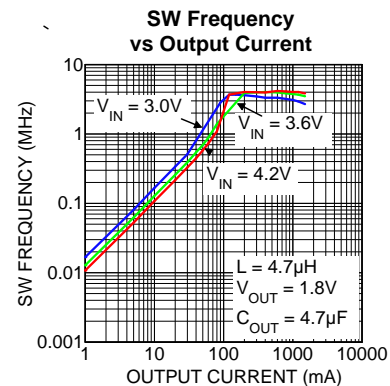
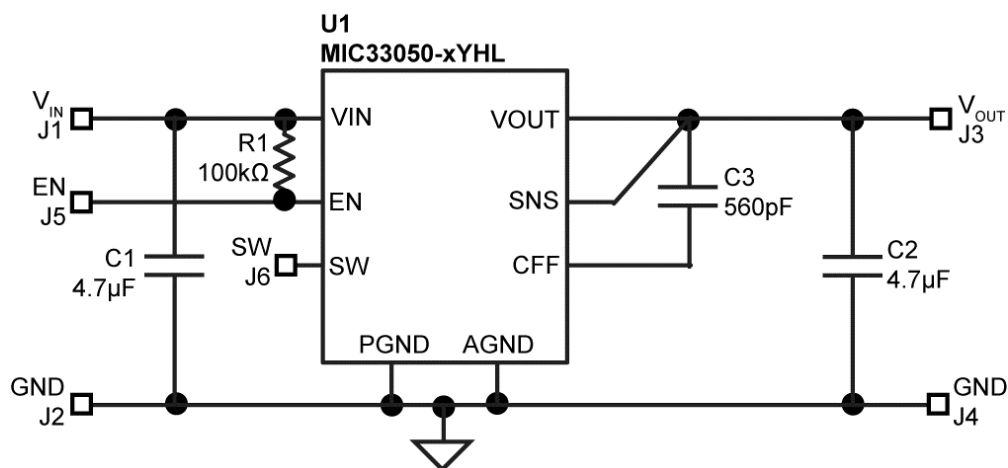

Figure 2. SW Frequency vs. Output Current

MIC33050 Typical Circuit (Fixed)



Bill of Materials

Item	Part Number	Manufacturer	Description	Qty.
C1, C2	C1608X5R0J475K	TDK ⁽¹⁾	4.7μF Ceramic Capacitor, 6.3V, X5R, Size 0603	2
C3	C1608C0G1H561J	TDK	560pF Ceramic Capacitor, 50V, NPO, Size 0603	1
R1	CRCW0603100KFKEA	Vishay ⁽²⁾	100kΩ, Tolerance 1%, Size 0603	1
U1	MIC33050-xYHL	Micrel, Inc. ⁽³⁾	4MHz Internal Inductor PWM Buck Regulator with HyperLight Load Mode	1

Notes:

1. TDK: www.tdk.com.
2. Vishay: www.vishay.com.
3. Micrel, Inc: www.micrel.com.

MIC33050 Typical Circuit (Adjustable)

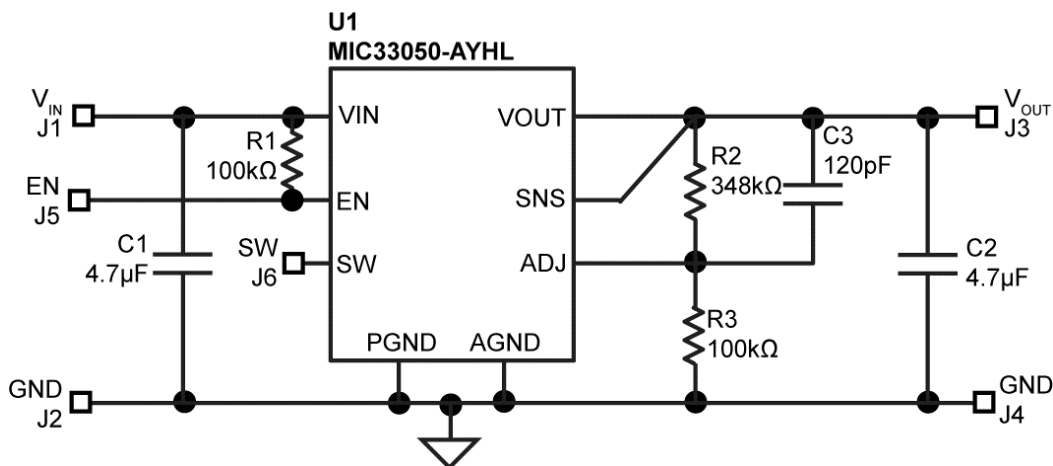

Bill of Materials

Item	Part Number	Manufacturer	Description	Qty.
C1, C2	C1608X5R0J475K	TDK ⁽¹⁾	4.7μF Ceramic Capacitor, 6.3V, X5R, Size 0603	2
C3	C1608C0G1H121J	TDK	120pF Ceramic Capacitor, 50V, NPO, Size 0603	1
R1, R3	CRCW0603100KFKEA	Vishay ⁽²⁾	100kΩ, Tolerance 1%, Size 0603	2
R2	CRCW0603348KFKEA	Vishay	348kΩ, Tolerance 1%, Size 0603	1
U1	MIC33050-AYHL	Micrel, Inc. ⁽³⁾	4MHz Internal Inductor PWM Buck Regulator with HyperLight Load Mode	1

Notes:

1. TDK: www.tdk.com.
2. Vishay: www.vishay.com.
3. Micrel, Inc: www.micrel.com.

PCB Layout Recommendations

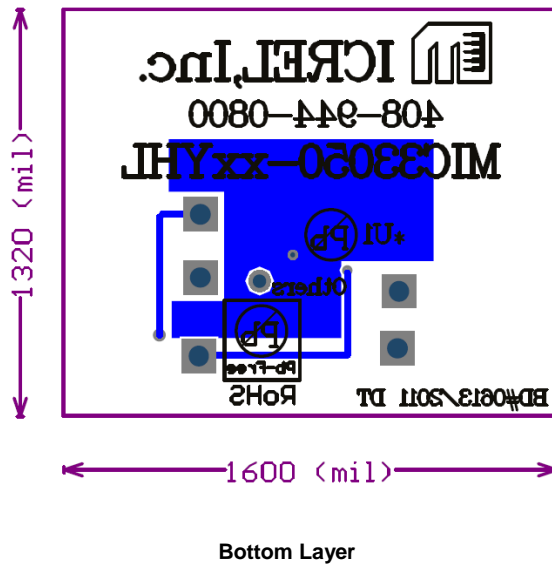
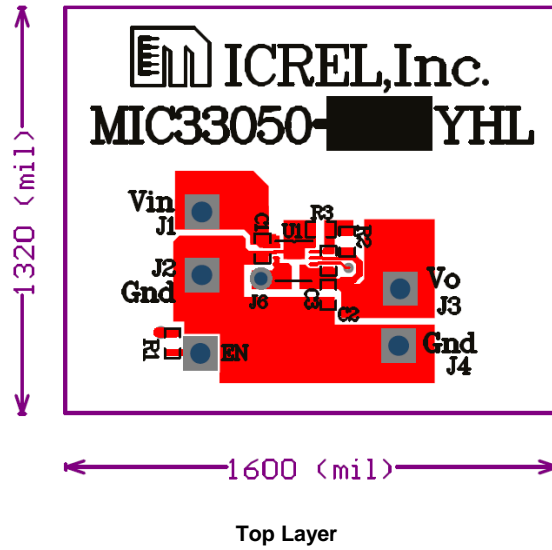

MICREL, INC. 2180 FORTUNE DRIVE SAN JOSE, CA 95131 USA
TEL +1 (408) 944-0800 FAX +1 (408) 474-1000 WEB <http://www.micrel.com>

Micrel makes no representations or warranties with respect to the accuracy or completeness of the information furnished in this data sheet. This information is not intended as a warranty and Micrel does not assume responsibility for its use. Micrel reserves the right to change circuitry, specifications and descriptions at any time without notice. No license, whether express, implied, arising by estoppel or otherwise, to any intellectual property rights is granted by this document. Except as provided in Micrel's terms and conditions of sale for such products, Micrel assumes no liability whatsoever, and Micrel disclaims any express or implied warranty relating to the sale and/or use of Micrel products including liability or warranties relating to fitness for a particular purpose, merchantability, or infringement of any patent, copyright or other intellectual property right.

Micrel Products are not designed or authorized for use as components in life support appliances, devices or systems where malfunction of a product can reasonably be expected to result in personal injury. Life support devices or systems are devices or systems that (a) are intended for surgical implant into the body or (b) support or sustain life, and whose failure to perform can be reasonably expected to result in a significant injury to the user. A Purchaser's use or sale of Micrel Products for use in life support appliances, devices or systems is a Purchaser's own risk and Purchaser agrees to fully indemnify Micrel for any damages resulting from such use or sale.

© 2014 Micrel, Incorporated.

Mouser Electronics

Authorized Distributor

Click to View Pricing, Inventory, Delivery & Lifecycle Information:

[Micrel:](#)

[MIC33050-4YHL EV](#) [MIC33050-SYHL EV](#) [MIC33050-AYHL EV](#) [MIC33050-GYHL-EV](#) [MIC33050-AYHL-EV](#)
[MIC33050-CYHL-EV](#) [MIC33050-SYHL-EV](#) [MIC33050-4YHL-EV](#)

Компания «Океан Электроники» предлагает заключение долгосрочных отношений при поставках импортных электронных компонентов на взаимовыгодных условиях!

Наши преимущества:

- Поставка оригинальных импортных электронных компонентов напрямую с производств Америки, Европы и Азии, а так же с крупнейших складов мира;
- Широкая линейка поставок активных и пассивных импортных электронных компонентов (более 30 млн. наименований);
- Поставка сложных, дефицитных, либо снятых с производства позиций;
- Оперативные сроки поставки под заказ (от 5 рабочих дней);
- Экспресс доставка в любую точку России;
- Помощь Конструкторского Отдела и консультации квалифицированных инженеров;
- Техническая поддержка проекта, помощь в подборе аналогов, поставка прототипов;
- Поставка электронных компонентов под контролем ВП;
- Система менеджмента качества сертифицирована по Международному стандарту ISO 9001;
- При необходимости вся продукция военного и аэрокосмического назначения проходит испытания и сертификацию в лаборатории (по согласованию с заказчиком);
- Поставка специализированных компонентов военного и аэрокосмического уровня качества (Xilinx, Altera, Analog Devices, Intersil, Interpoint, Microsemi, Actel, Aeroflex, Peregrine, VPT, Syfer, Eurofarad, Texas Instruments, MS Kennedy, Miteq, Cobham, E2V, MA-COM, Hittite, Mini-Circuits, General Dynamics и др.);

Компания «Океан Электроники» является официальным дистрибьютором и эксклюзивным представителем в России одного из крупнейших производителей разъемов военного и аэрокосмического назначения «JONHON», а так же официальным дистрибьютором и эксклюзивным представителем в России производителя высокотехнологичных и надежных решений для передачи СВЧ сигналов «FORSTAR».



JONHON

«JONHON» (основан в 1970 г.)

Разъемы специального, военного и аэрокосмического назначения:

(Применяются в военной, авиационной, аэрокосмической, морской, железнодорожной, горно- и нефтедобывающей отраслях промышленности)

«FORSTAR» (основан в 1998 г.)

ВЧ соединители, коаксиальные кабели, кабельные сборки и микроволновые компоненты:

(Применяются в телекоммуникациях гражданского и специального назначения, в средствах связи, РЛС, а так же военной, авиационной и аэрокосмической отраслях промышленности).



Телефон: 8 (812) 309-75-97 (многоканальный)

Факс: 8 (812) 320-03-32

Электронная почта: ocean@oceanchips.ru

Web: <http://oceanchips.ru/>

Адрес: 198099, г. Санкт-Петербург, ул. Калинина, д. 2, корп. 4, лит. А