

High-Voltage Step-Up LED Driver with UVLO and Open Load Protection

Features:

- 36V, 800 mΩ Integrated Switch
- Up to 92% Efficiency
- Drive LED Strings in Constant Current
- 1.3A Peak Input Current Limit:
 - I_{LED} up to 200 mA @ 5.0V V_{IN} , 4 White LEDs
 - I_{LED} up to 125 mA @ 3.3V V_{IN} , 4 White LEDs
 - I_{LED} up to 100 mA @ 4.2V V_{IN} , 8 White LEDs
- Input Voltage Range: 2.4V to 5.5V
- Feedback Voltage Reference: $V_{FB} = 300$ mV
- Undervoltage Lockout (UVLO):
 - UVLO @ V_{IN} Rising: 2.3V, typical
 - UVLO @ V_{IN} Falling: 1.85V, typical
- Sleep Mode with 20 nA Typical Quiescent Current
- PWM Operation: 500 kHz Switching Frequency
- Cycle-by-Cycle Current Limiting
- Internal Compensation
- Inrush Current Limiting and Internal Soft Start
- Open Load Protection (OLP) in the event of:
 - Feedback Pin Shorted to GND (Prevent Excessive Current into LEDs)
 - Disconnected LED String (Prevent Overvoltage to the Converter's Output and SW Pin)
- Overtemperature Protection
- Available Packages:
 - 5-Lead SOT-23
 - 8-Lead 2x3 TDFN

Applications:

- Two and Three-Cell Alkaline or NiMH/NiCd White LED Driver for Backlighting Products
- Li-Ion Battery LED Lighting Application
- Camera Flash
- LED Flashlights and Backlight Current Source
- Medical Equipment
- Portable Devices:
 - Hand-Held Gaming Devices
 - GPS Navigation Systems
 - LCD Monitors
 - Portable DVD Players

General Description:

The MCP1662 device is a compact, space-efficient, fixed-frequency, non-synchronous step-up converter optimized to drive LED strings with constant current from two and three-cell alkaline and NiMH/NiCd or one-cell Li-Ion or Li-Polymer batteries.

The device integrates a 36V, 800 mΩ low-side switch, which is protected by the 1.3A cycle-by-cycle inductor peak current limit operation. Low-voltage technology allows the MCP1662 to start-up without high inrush current or output overshoot. All compensation and protection circuitry is integrated to minimize the number of external components.

The internal feedback (V_{FB}) voltage is set to 300 mV for low power dissipation when sensing and regulating the LED current. A single resistor sets the LED current.

The device features an UVLO which avoids start-up with low inputs or discharged batteries for two cell-powered applications.

There is an open load protection (OLP) which turns off the operation in situations when the LED string is accidentally disconnected or the feedback pin is short-circuited to GND.

For standby applications ($EN = GND$), the device stops switching, enters in Sleep mode and consumes 20 nA typical of input current.

Package Types

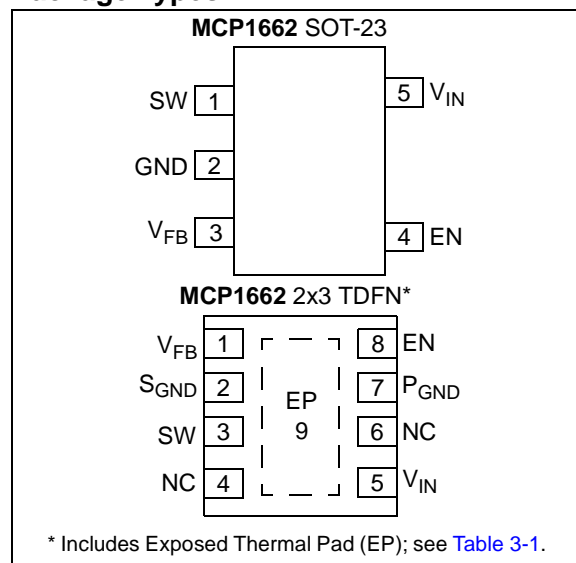

MCP1662

Typical Application

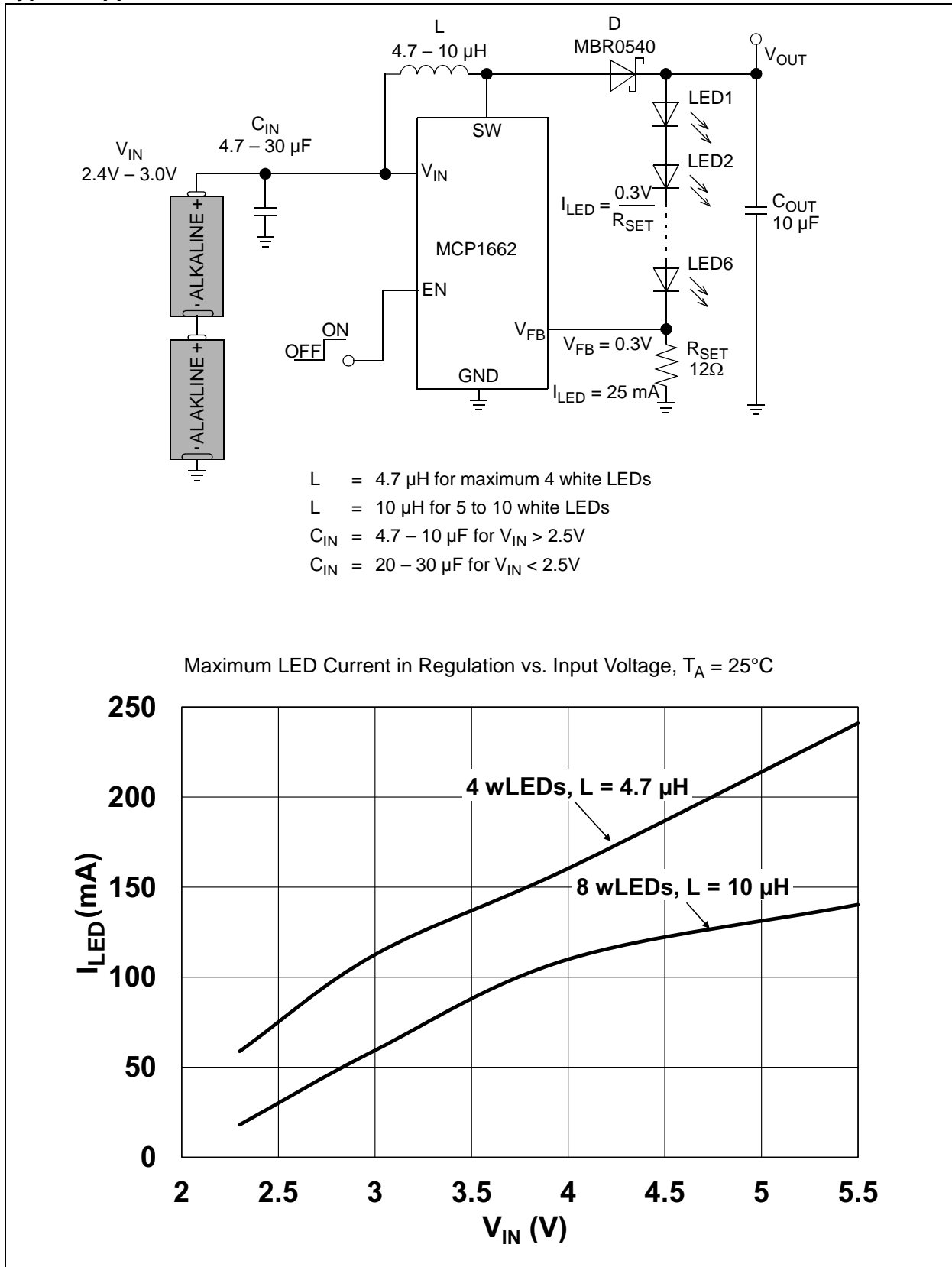

1.0 ELECTRICAL CHARACTERISTICS

Absolute Maximum Ratings †

$V_{SW} - GND$	+36V
EN, $V_{IN} - GND$	+6.0V
V_{FB}	+0.35V
Power Dissipation	Internally Limited
Storage Temperature	-65°C to +150°C
Ambient Temperature with Power Applied	-40°C to +125°C
Operating Junction Temperature	-40°C to +150°C
ESD Protection On All Pins:	
HBM	4 kV
MM	300V

† **Notice:** Stresses above those listed under “Maximum Ratings” may cause permanent damage to the device. This is a stress rating only and functional operation of the device at those or any other conditions above those indicated in the operational sections of this specification is not intended. Exposure to maximum rating conditions for extended periods may affect device reliability.

DC AND AC CHARACTERISTICS

Electrical Specifications: Unless otherwise specified, all limits apply for typical values at ambient temperature $T_A = +25^\circ\text{C}$, $V_{IN} = 3.3\text{V}$, $V_{OUT} = 9\text{V}$ or 3 wLEDs ($V_F = 2.75\text{V}$ @ $I_F = 20\text{mA}$ or $V_F = 3.1\text{V}$ @ $I_F = 100\text{mA}$), $I_{LED} = 20\text{mA}$, $C_{IN} = C_{OUT} = 10\ \mu\text{F}$, X7R ceramic, $L = 4.7\ \mu\text{H}$.

Boldface specifications apply over the controlled T_A range of -40°C to $+125^\circ\text{C}$.

Parameters	Sym.	Min.	Typ.	Max.	Units	Conditions
Input Voltage Range	V_{IN}	2.4	—	5.5	V	Note 1
Undervoltage Lockout (UVLO)	$UVLO_{START}$	—	2.3	—	V	V_{IN} rising, $I_{LED} = 20\text{mA}$
	$UVLO_{STOP}$	—	1.85	—	V	V_{IN} falling, $I_{LED} = 20\text{mA}$
Maximum Output Voltage	V_{OUTmax}	—	—	32	V	36V Transients (Note 1)
Maximum Output Current	I_{OUT}	—	100	—	mA	4.2V V_{IN} , 8 LEDs
			125	—	mA	3.3V V_{IN} , 4 LEDs
			200	—	mA	5.0V V_{IN} , 4 LEDs
Feedback Voltage Reference	V_{FB}	275	300	325	mV	
Feedback Open Load Protection (OLP) Threshold	V_{FB_OLP}	—	50	—	mV	V_{FB} falling (Note 2)
Feedback Input Bias Current	I_{VFB}	—	0.005	—	μA	
Shutdown Quiescent Current	I_{QSHDN}	—	0.02	—	μA	EN = GND
NMOS Peak Switch Current Limit	$I_{N(MAX)}$	—	1.3	—	A	Note 2
NMOS Switch Leakage	I_{NLK}	—	0.4	—	μA	$V_{IN} = V_{SW} = 5\text{V}$; $V_{OUT} = 5.5\text{V}$ $V_{EN} = V_{FB} = \text{GND}$
NMOS Switch ON Resistance	$R_{DS(ON)}$	—	0.8	—	Ω	$V_{IN} = 5\text{V}$, $I_{LED} = 100\text{mA}$, 4 series wLEDs (Note 2)
Feedback Voltage Line Regulation	$ (\Delta V_{FB}/V_{FB})/\Delta V_{IN} $	—	0.25	—	%/V	$V_{IN} = 3.0\text{V}$ to 5V
Maximum Duty Cycle	DC_{MAX}	—	90	—	%	Note 2
Switching Frequency	f_{SW}	425	500	575	kHz	$\pm 15\%$

Note 1: Minimum input voltage in the range of V_{IN} ($V_{IN} < 5.5\text{V} < V_{OUT}$) depends on the maximum duty cycle (DC_{MAX}) and on the output voltage (V_{OUT}), according to the boost converter equation:
 $V_{INmin} = V_{OUT} \times (1 - DC_{MAX})$. Output voltage is equal to the LED voltage plus the voltage on the sense resistor ($V_{LED} + V_{RSET}$).

2: Determined by characterization, not production tested.

MCP1662

DC AND AC CHARACTERISTICS (CONTINUED)

Electrical Specifications: Unless otherwise specified, all limits apply for typical values at ambient temperature $T_A = +25^\circ\text{C}$, $V_{IN} = 3.3\text{V}$, $V_{OUT} = 9\text{V}$ or 3 LEDs ($V_F = 2.75\text{V}$ @ $I_F = 20\text{ mA}$ or $V_F = 3.1\text{V}$ @ $I_F = 100\text{ mA}$), $I_{LED} = 20\text{ mA}$, $C_{IN} = C_{OUT} = 10\text{ }\mu\text{F}$, X7R ceramic, $L = 4.7\text{ }\mu\text{H}$.
Boldface specifications apply over the controlled T_A range of -40°C to $+125^\circ\text{C}$.

Parameters	Sym.	Min.	Typ.	Max.	Units	Conditions
EN Input Logic High	V_{IH}	85	—	—	% of V_{IN}	
EN Input Logic Low	V_{IL}	—	—	7.5	% of V_{IN}	
EN Input Leakage Current	I_{ENLK}	—	0.025	—	μA	$V_{EN} = 5\text{V}$
Soft Start Time	t_{SS}	—	150	—	ms	EN Low-to-High, 90% of I_{LED} (Note 2, Figure 2-10)
Thermal Shutdown Die Temperature	T_{SD}	—	150	—	$^\circ\text{C}$	
Die Temperature Hysteresis	T_{SDHYS}	—	15	—	$^\circ\text{C}$	

Note 1: Minimum input voltage in the range of V_{IN} ($V_{IN} < 5.5\text{V} < V_{OUT}$) depends on the maximum duty cycle (DC_{MAX}) and on the output voltage (V_{OUT}), according to the boost converter equation:
 $V_{INmin} = V_{OUT} \times (1 - DC_{MAX})$. Output voltage is equal to the LED voltage plus the voltage on the sense resistor ($V_{LED} + V_{RSET}$).

2: Determined by characterization, not production tested.

TEMPERATURE SPECIFICATIONS

Electrical Specifications: Unless otherwise specified, all limits apply for typical values at ambient temperature $T_A = +25^\circ\text{C}$, $V_{IN} = 3.0\text{V}$, $I_{OUT} = 20\text{ mA}$, $V_{OUT} = 12\text{V}$, $C_{IN} = C_{OUT} = 10\text{ }\mu\text{F}$, X7R ceramic, $L = 4.7\text{ }\mu\text{H}$.
Boldface specifications apply over the air-forced T_A range of -40°C to $+125^\circ\text{C}$.

Parameters	Sym.	Min.	Typ.	Max.	Units	Conditions
Temperature Ranges						
Operating Junction Temperature Range	T_J	-40	—	+125	$^\circ\text{C}$	Steady State
Storage Temperature Range	T_A	-65	—	+150	$^\circ\text{C}$	
Maximum Junction Temperature	T_J	—	—	+150	$^\circ\text{C}$	Transient
Package Thermal Resistances						
Thermal Resistance, 5L-SOT23	θ_{JA}	—	201.0	—	$^\circ\text{C/W}$	
Thermal Resistance, 8L 2x3 TDFN	θ_{JA}	—	52.5	—	$^\circ\text{C/W}$	

2.0 TYPICAL PERFORMANCE CURVES

Note: The graphs and tables provided following this note are a statistical summary based on a limited number of samples and are provided for informational purposes only. The performance characteristics listed herein are not tested or guaranteed. In some graphs or tables, the data presented may be outside the specified operating range (e.g., outside specified power supply range) and therefore outside the warranted range.

Note: Unless otherwise indicated: $V_{IN} = 3.3V$, $I_{LED} = 20\text{ mA}$, $V_{OUT} = 12V$ or 4 wLEDs ($V_F = 2.75V$ @ $I_F = 20\text{ mA}$ or $V_F = 3.1V$ @ $I_F = 100\text{ mA}$), $C_{IN} = C_{OUT} = 10\text{ }\mu\text{F}$, X7R ceramic, $L = 4.7\text{ }\mu\text{H}$.

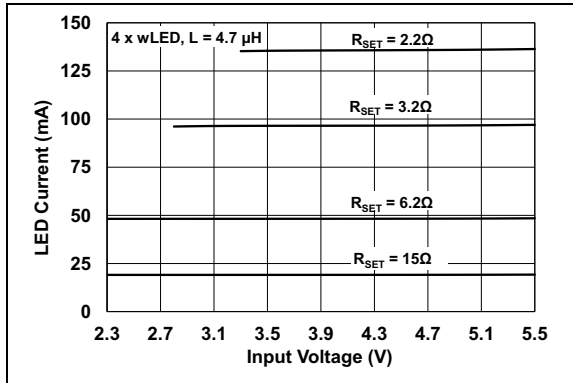

FIGURE 2-1: 4 White LEDs, I_{LED} vs. V_{IN} .

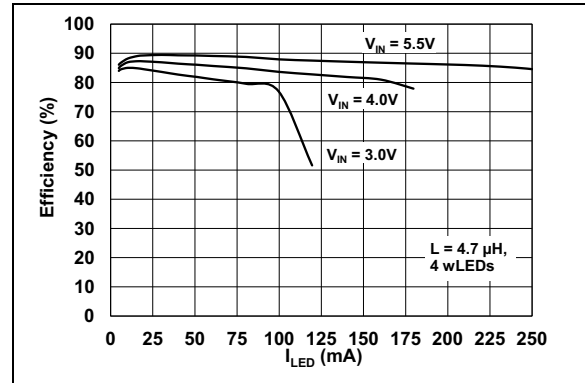

FIGURE 2-4: 4 White LEDs, Efficiency vs. I_{LED} .

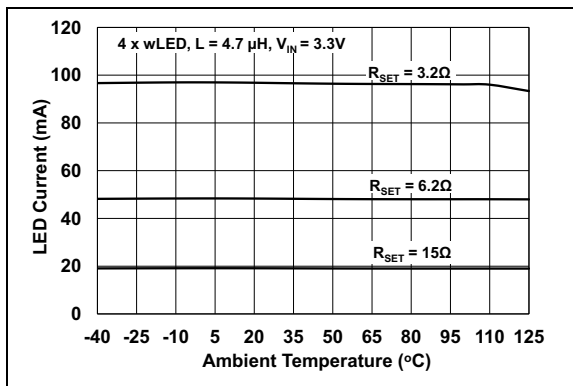

FIGURE 2-2: 4 White LEDs, I_{LED} vs. Ambient Temperature.

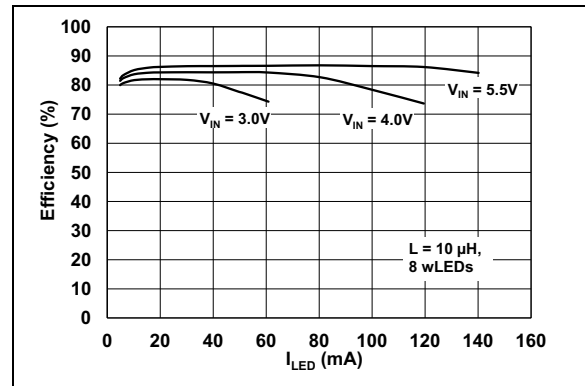

FIGURE 2-5: 8 White LEDs, Efficiency vs. I_{LED} .

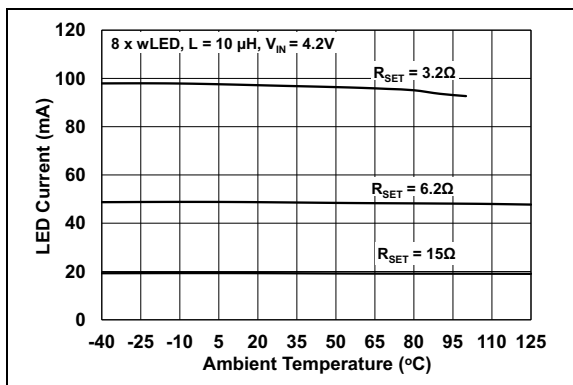

FIGURE 2-3: 8 White LEDs, I_{LED} vs. Ambient Temperature.

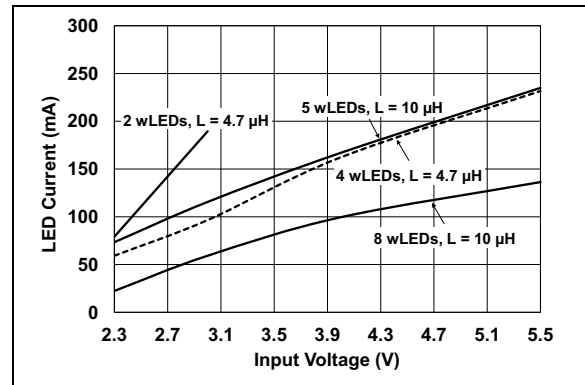

FIGURE 2-6: Maximum I_{LED} vs. V_{IN} .

MCP1662

Note: Unless otherwise indicated: $V_{IN} = 3.3V$, $I_{LED} = 20\text{ mA}$, $V_{OUT} = 12V$ or 4 wLEDs ($V_F = 2.75V @ I_F = 20\text{ mA}$ or $V_F = 3.1V @ I_F = 100\text{ mA}$), $C_{IN} = C_{OUT} = 10\text{ }\mu\text{F}$, X7R ceramic, $L = 4.7\text{ }\mu\text{H}$.

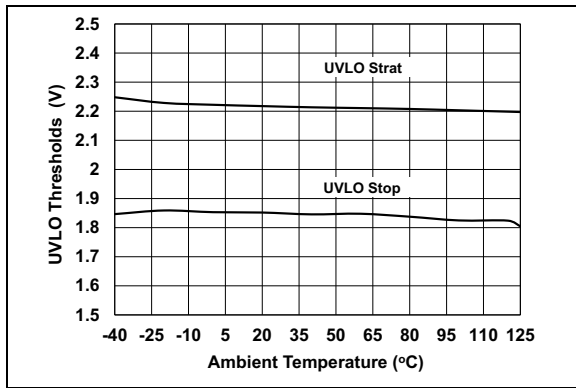

FIGURE 2-7: Undervoltage Lockout (UVLO) vs. Ambient Temperature.

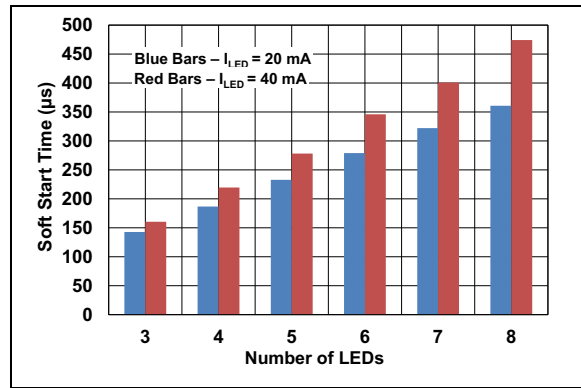

FIGURE 2-10: Soft Start Time vs. LED Number.

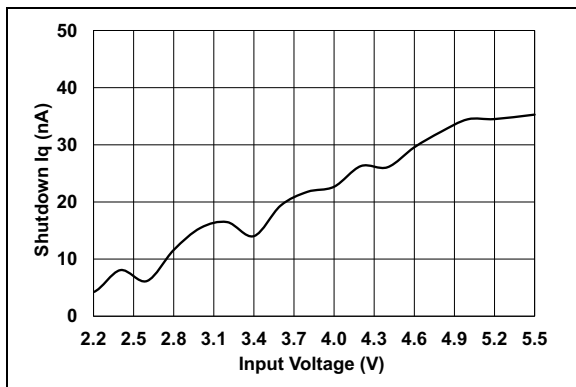

FIGURE 2-8: Shutdown Quiescent Current, I_{QSHDN} , vs. V_{IN} ($EN = GND$).

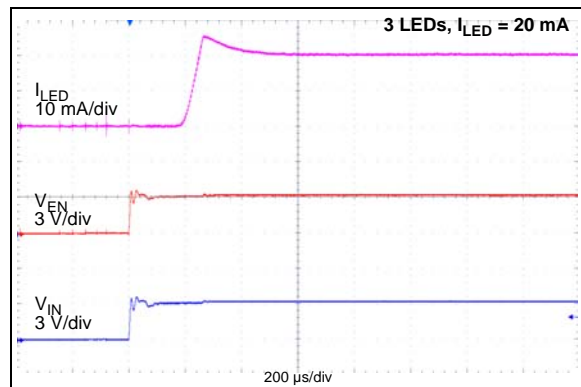

FIGURE 2-11: Start-Up When $V_{IN} = V_{ENABLE}$.

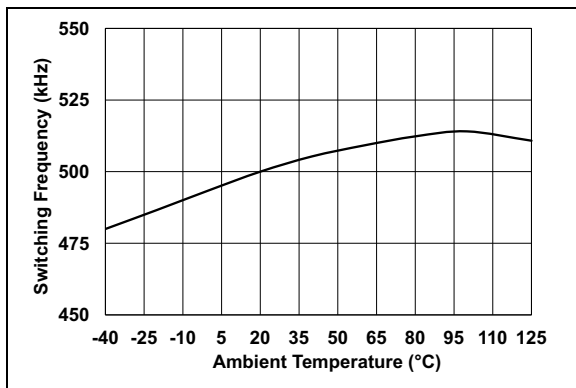

FIGURE 2-9: Switching Frequency, f_{SW} , vs. Ambient Temperature.

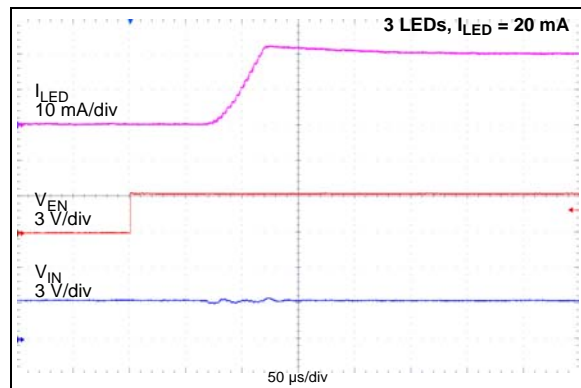

FIGURE 2-12: Start-Up After Enable.

Note: Unless otherwise indicated: $V_{IN} = 3.3V$, $I_{LED} = 20\text{ mA}$, $V_{OUT} = 12V$ or 4 wLEDs ($V_F = 2.75V @ I_F = 20\text{ mA}$ or $V_F = 3.1V @ I_F = 100\text{ mA}$), $C_{IN} = C_{OUT} = 10\text{ }\mu\text{F}$, X7R ceramic, $L = 4.7\text{ }\mu\text{H}$.

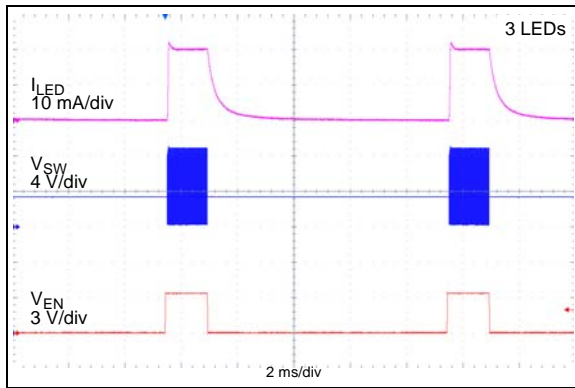

FIGURE 2-13: 100 Hz PWM Dimming, 15% Duty Cycle.

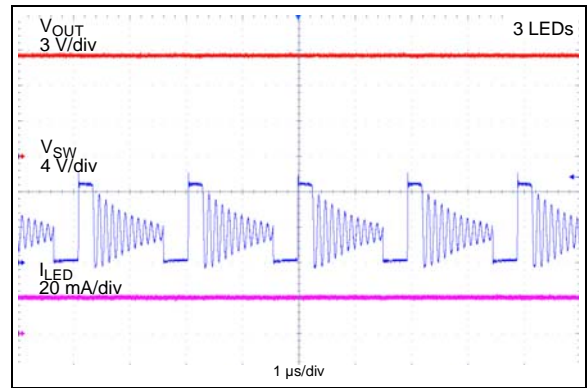

FIGURE 2-16: 3.3V Input, 20 mA 3wLEDs PWM Discontinuous Mode Waveforms.

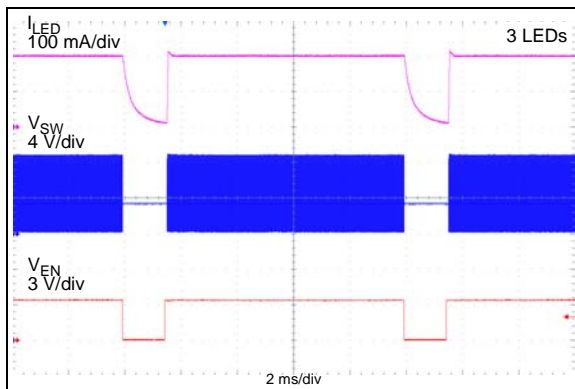

FIGURE 2-14: 100 Hz PWM Dimming, 85% Duty Cycle.

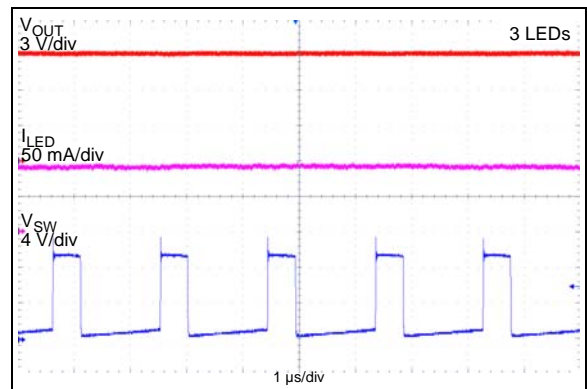

FIGURE 2-17: 3.3V Input, 100 mA 3wLEDs PWM Continuous Mode Waveforms.

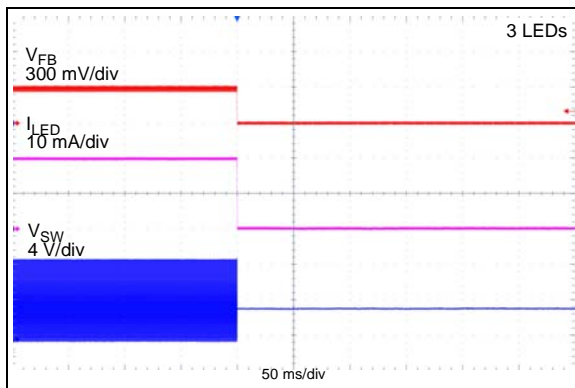

FIGURE 2-15: Open Load (LED Fail or FB to GND) Response.

MCP1662

3.0 PIN DESCRIPTIONS

The descriptions of the pins are listed in [Table 3-1](#).

TABLE 3-1: PIN FUNCTION TABLE

MCP1661 SOT23	MCP1661 2x3 TDFN	Symbol	Description
3	1	V_{FB}	Feedback Voltage Pin
—	2	S_{GND}	Signal Ground Pin (TDFN only)
1	3	SW	Switch Node, Boost Inductor Input Pin
—	4, 6	NC	Not Connected
5	5	V_{IN}	Input Voltage Pin
—	7	P_{GND}	Power Ground Pin (TDFN only)
4	8	EN	Enable Control Input Pin
—	9	EP	Exposed Thermal Pad (EP); must be connected to Ground. (TDFN only)
2	—	GND	Ground Pin (SOT-23 only)

3.1 Feedback Voltage Pin (V_{FB})

The V_{FB} pin is used to regulate the voltage across the R_{SET} sense resistor to 300 mV to keep the output LED current in regulation. Connect the cathode of the LED to the V_{FB} pin.

3.2 Signal Ground Pin (S_{GND})

The signal ground pin is used as a return for the integrated reference voltage and error amplifier. The signal ground and power ground must be connected externally in one point.

3.3 Switch Node Pin (SW)

Connect the inductor from the input voltage to the SW pin. The SW pin carries inductor current and has a typical value of 1.3A peak. The integrated N-Channel switch drain is internally connected to the SW node.

3.4 Not Connected (NC)

This is an unconnected pin.

3.5 Power Supply Input Voltage Pin (V_{IN})

Connect the input voltage source to V_{IN} . The input source should be decoupled from GND with a 4.7 μ F minimum capacitor.

3.6 Power Ground Pin (P_{GND})

The power ground pin is used as a return for the high-current N-Channel switch. The P_{GND} and S_{GND} pins are connected externally. The signal ground and power ground must be connected externally in one point.

3.7 Enable Pin (EN)

The EN pin is a logic-level input used to enable or disable device switching and lower quiescent current while disabled. A logic high (>85% of V_{IN}) will enable the regulator output. A logic low (<7.5% of V_{IN}) will ensure that the regulator is disabled.

3.8 Exposed Thermal Pad (EP)

There is no internal electrical connection between the Exposed Thermal Pad (EP) and the S_{GND} and P_{GND} pins. They must be connected to the same potential on the Printed Circuit Board (PCB).

3.9 Ground Pin (GND)

The ground or return pin is used for circuit ground connection. The length of the trace from the input cap return, the output cap return and the GND pin must be as short as possible to minimize noise on the GND pin. The SOT23-5 package uses a single ground pin.

4.0 DETAILED DESCRIPTION

4.1 Device Overview

The MCP1662 device is a fixed-frequency, synchronous step-up converter, with a low voltage reference of 300 mV, optimized to keep the output current constant by regulating the voltage across the feedback resistor (R_{SET}). The MCP1662 integrates a Peak Current mode architecture and delivers high-efficiency conversion for LED lighting application while it is powered by two-cell and three-cell Alkaline, Ultimate Lithium, NiMH, NiCd and single-cell Li-Ion battery inputs. The maximum input voltage is 5.5V. A high level of integration lowers total system cost, eases implementation and reduces board area.

The conventional boost converter with a high voltage reference has a high voltage drop across the LED series current limit resistor. The power dissipated in this resistor, which is usually in series with the LED string, reduces the total efficiency conversion of an LED driver solution. Therefore, the voltage drop on the sense resistor (R_{SET}) used to regulate the LED current must be low. In the case of MCP1662, the V_{FB} value is 300 mV.

The device features controlled start-up voltage ($UVLO_{START} = 2.3V$) and an open load protection in case the LED fails or a short circuit of the V_{FB} pin to GND occurs. Once the V_{FB} voltage drops to 50 mV typical, the device stops switching and the output voltage will be equal to the input voltage (minus a diode drop voltage). This feature prevents damage to the device and LEDs in case of an accidental event like the one described above.

The 800 m Ω , 36V integrated switch is protected by the 1.3A cycle-by-cycle inductor peak current limit operation. When the Enable pin is pulled to ground ($EN = GND$), the device stops switching, enters in Shutdown mode and consumes less than 50 nA of input current ([Figure 2-8](#)).

MCP1662

4.2 Functional Description

The MCP1662 is a compact, high-efficiency, fixed 500 kHz frequency, step-up DC-DC converter that operates as a constant current generator for applications powered by either two-cell or three-cell alkaline or Lithium Energizer, three-cell NiCd or NiMH or one-cell Li-Ion or Li-Polymer batteries.

Figure 4-1 depicts the functional block diagram of the MCP1662. It incorporates a Current mode control scheme, in which the PWM ramp signal is derived from the NMOS power switch current (V_{SENSE}). This ramp signal adds slope ramp compensation signal (V_{RAMP}) and is compared to the output of the error amplifier (V_{ERROR}) to control the on-time of the power switch.

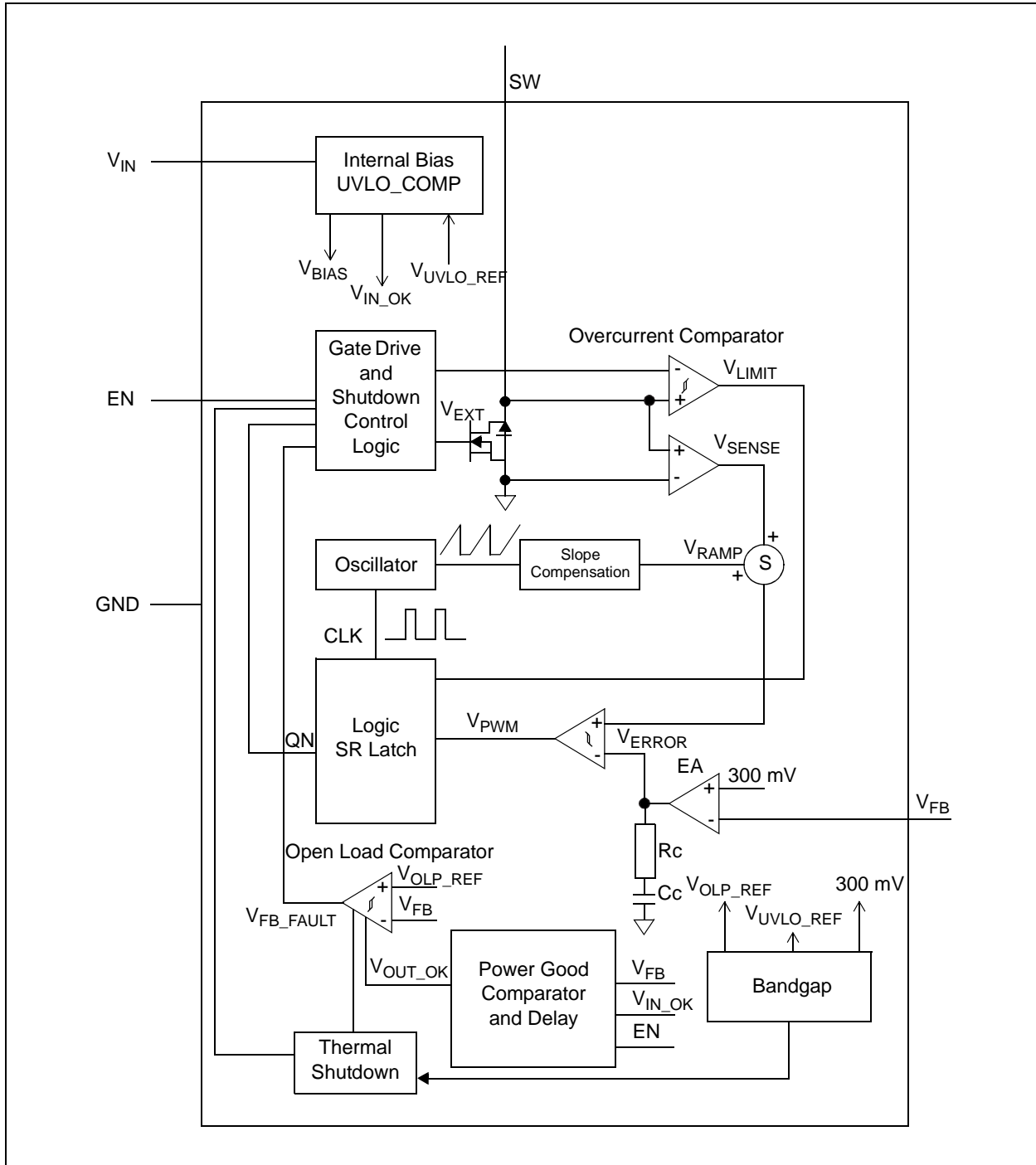

FIGURE 4-1: MCP1662 Simplified Block Diagram.

4.2.1 INTERNAL BIAS

The MCP1662 gets its bias from V_{IN} . The V_{IN} bias is used to power the device and drive circuits over the entire operating range.

4.2.2 START-UP VOLTAGE AND SOFT START

The MCP1662 is capable of starting from two alkaline cells. MCP1662 starts switching at approximately 2.3V typical for a light load current. Once started, the device will continue to operate down to 1.85V, typical.

There is a soft-start feature which provides a way to limit the inrush current drawn from the input (batteries) during start-up. The start-up time is dependent on the output current (approximately 150 μ s at 20 mA LED current typical, 3 wLEDs; see [Figure 2-10](#)). The soft start has an important role in applications where the switch will reach 32V. During start-up, excessively high switch current, together with the presence of high voltage, can overstress the NMOS switch.

When the device is powered, the output capacitor charges to a value close to the input voltage (V_{IN} minus a Schottky diode voltage drop). To avoid high inrush currents that occur when charging the output capacitor during start-up, the switch peak current is limited to 1.3A. The overshoot on output is limited by slowly increasing the reference of the error amplifier. There is an internal reference voltage which charges an internal capacitor with a weak current source. The voltage on this capacitor slowly ramps the limit. The soft-start capacitor is completely discharged in the event of a commanded shutdown or a thermal shutdown. Once the voltage on the output capacitor reaches the sum of the forward voltages of the LEDs, the MCP1662 device enters constant current operation.

Due to the direct path from input to output, in the case of pulsing enable applications (EN voltage switches from low-to-high), the output capacitor is already charged and the output starts from a value close to the input voltage.

The internal oscillator has a delayed start to let the output capacitor completely charge to the input voltage value.

4.2.3 UNDERVOLTAGE LOCKOUT (UVLO)

MCP1662 features an UVLO which prevents fault operation below 1.85V typical, which corresponds to the value of two discharged alkaline batteries.

Essentially, there is a hysteresis comparator, which monitors V_{IN} and at the reference voltage derived from the bandgap.

The device starts its normal operation at 2.3V typical input, which corresponds to the voltage value of two rechargeable Ni-MH or Ni-Cd cells. A hysteresis is set to avoid input transients (temporary V_{IN} drop), which might trigger the lower UVLO threshold and restart the device.

When the input voltage is below the $UVLO_{START}$ threshold, the device is operating with limited specification.

4.2.4 ENABLE PIN

The MCP1662 device enables switching when the EN pin is set high. The device is put into Shutdown mode when the EN pin is set low. To enable the boost converter, the EN voltage level must be greater than 85% of the V_{IN} voltage. To disable the boost converter, the EN voltage must be less than 7.5% of the V_{IN} voltage.

4.2.4.1 Shutdown Mode. Input to Output Path (EN = GND)

In Shutdown mode, the MCP1662 device stops switching and all internal control circuitry is switched off. The input voltage will be bypassed to output through the inductor and the Schottky diode.

While the device stops switching, V_{OUT} is equal to the output capacitor voltage, which slowly discharges on the leak path (from V_{OUT} to a value close to V_{IN}) after the LEDs are turned off.

In Shutdown mode, the current consumed by the MCP1662 device from batteries is very low (below 50 nA over V_{IN} range; see [Figure 2-8](#)).

4.2.5 PWM MODE OPERATION

MCP1662 operates as a fixed-frequency, non-synchronous converter. The switching frequency is maintained with a precision oscillator at 500 kHz.

Lossless current sensing converts the peak current signal to a voltage (V_{SENSE}) and adds it to the internal slope compensation (V_{RAMP}). This summed signal is compared to the voltage error amplifier output (V_{ERROR}) to provide a peak current control signal (V_{PWM}) for the PWM. The slope compensation signal depends on the input voltage. Therefore, the converter provides the proper amount of slope compensation to ensure stability. The peak limit current is set to 1.3A.

MCP1662

4.2.6 INTERNAL COMPENSATION

The error amplifier, with its associated compensation network, completes the closed-loop system by comparing the output voltage to a reference at the input of the error amplifier and by feeding the amplified and inverted signal to the control input of the inner current loop. The compensation network provides phase leads and lags at appropriate frequencies to cancel excessive phase lags and leads of the power circuit. All necessary compensation components and slope compensation are integrated.

4.2.7 OPEN LOAD PROTECTION (OLP)

An internal V_{FB} fault signal turns off the PWM signal (V_{EXT}) when output goes out of regulation in the event of:

- open load (LED string fails)
- short circuit of the feedback pin to GND

In any of the above events, for a regular integrated circuit (IC) without any protection implemented, the V_{FB} voltage drops to ground potential, its N-channel transistor is forced to switch at full duty cycle and V_{OUT} rises. This fault event may cause the SW pin to exceed its maximum voltage rating and may damage the boost regulator IC, its external components and the LEDs. To avoid these, MCP1662 has implemented an open load protection (OLP) which turns off PWM switching when such a condition is detected. There is an overvoltage comparator with 50 mV reference which monitors the V_{FB} voltage.

If the OLP event occurs with the input voltage below the $UVLO_{START}$ threshold and V_{FB} remains under 50 mV due to weak input (discharged batteries) or an overload condition, the device latches its output; it resumes after power-up.

The OLP comparator is disabled during start-up sequences and thermal shutdown. Because the OLP comparator is turned off during start-up, care must be taken when using PWM dimming on the EN pin, as this might damage the device if a fault event occurs.

4.2.8 OVERCURRENT LIMIT

The MCP1662 device uses a 1.3A cycle-by-cycle input current limit to protect the N-channel switch. There is an overcurrent comparator which resets the drive latch when the peak of the inductor current reaches the limit. In current limitation, the output voltage and load current start dropping.

4.2.9 OUTPUT SHORT CIRCUIT CONDITION

Like all non-synchronous boost converters, the MCP1662 inductor current will increase excessively during a short circuit on the converter's output. Short circuit on the output will cause the diode rectifier to fail and the inductor's temperature to rise or even to fail. When the diode fails, the SW pin becomes a high-impedance node, it remains connected only to the inductor and the resulting excessive ringing may cause damage to the MCP1662 device.

4.2.10 OVERTEMPERATURE PROTECTION

Overtemperature protection circuitry is integrated into the MCP1662 device. This circuitry monitors the device junction temperature and shuts the device off if the temperature exceeds $+150^{\circ}\text{C}$. The device will automatically restart when the junction temperature drops by 15°C . The OLP is disabled during an overtemperature condition.

5.0 APPLICATION INFORMATION

5.1 Typical Applications

The MCP1662 non-synchronous boost LED current regulator operates over a wide output range up to 32V, which allows it to drive up to 10 LEDs in series connection. The input voltage ranges from 2.4V to 5.5V. The device operates down to 1.85V with limited specification. The UVLO typical thresholds are set to 2.3V when V_{IN} is ramping and to 1.85V when V_{IN} is falling. Output current capability increases with the input voltage and is limited by the 1.3A typical peak input current limit. Typical characterization curves in this data sheet are presented to display the typical output current capability.

5.2 LED Brightness Control

5.2.1 ADJUSTABLE CONSTANT CURRENT CALCULATIONS

To calculate the resistor value to set the LED current, use Equation 5-1, where R_{SET} is connected to V_{FB} and GND. The reference voltage, V_{FB} , is 300 mV. The calculated current does not depend on the number of LEDs in the string.

EQUATION 5-1:

$$I_{LED} = \frac{V_{FB}}{R_{SET}}$$

EXAMPLE 1:

$$\begin{aligned} V_{FB} &= 300 \text{ mV} \\ I_{LED} &= 25 \text{ mA} \\ R_{SET} &= 12\Omega \end{aligned}$$

EXAMPLE 2:

$$\begin{aligned} V_{FB} &= 300 \text{ mV} \\ I_{LED} &= 100 \text{ mA} \\ R_{SET} &= 3\Omega \end{aligned}$$

The power dissipated on the R_{SET} resistor is very low and equal to $V_{FB} \times I_{LED}$. For $I_{LED} = 100 \text{ mA}$, the power dissipated on the sense resistor is 30 mW and the efficiency of the conversion is high.

5.2.2 PWM DIMMING

LED brightness can also be controlled by setting the maximum current for the LED string (using Equation 5-1) and by lowering it in small steps, with variable duty cycle PWM signal applied to the EN pin. The maximum frequency for dimming is limited by the soft start, which varies with the LED current. By varying the duty cycle of the signal applied on the EN pin (from 0 to 100%), the LED current is changing linearly.

5.2.3 OUTPUT CURRENT CAPABILITY. MINIMUM INPUT VOLTAGE

The maximum device output current is dependent upon the input and output voltage. As there is a 1.3A inductor peak current limit, output current can go out of regulation before reaching the maximum duty cycle. (Note that, for boost converters, the average inductor current is equal to the input current.) Characterization graphs show device limits.

The maximum number of LEDs (n_{LED} in Equation 5-2) that can be placed in series and be driven is dependent on the maximum LED forward voltage (V_{Fmax}) and LED current set by the R_{SET} resistor. The voltage at the output of the MCP1662 plus a margin should be below 36V. Consider that V_{Fmax} has some variation over the operating temperature range and that the LED data sheet must be reviewed for the correct data to be introduced in Equation 5-2. A maximum of 10 white LEDs in series connection can be driven safely.

EQUATION 5-2:

$$((V_{Fmax} \times n_{LED}) + V_{FB}) < 36V$$

Characterization graphs show the maximum current the device can supply according to the numbers of LEDs at the output.

For example, to ensure a 100 mA load current for 4 LEDs (output equal to approximately 12V), a minimum of 3.1V input voltage is necessary. If an application requires to drive 8 LEDs and is powered by one Li-Ion battery (V_{IN} from 3.3V to 4.2V), the LED current the MCP1662 device can regulate is close to 75 mA (Figure 2-6).

MCP1662

5.2.4 OPEN LOAD PROTECTION

The MCP1662 device features an open load protection (OLP) in case the LED is disconnected from the output line. If the voltage on the V_{FB} pin drops below 50 mV, the device stops switching and prevents overvoltage on the output and SW pin and excessive current into LEDs.

OLP is not enabled during start-up and thermal shutdown events. Since OLP is not enabled during these events, a PWM dimming application on the EN pin needs extra overvoltage circuits such as a Zener diode connected in parallel with the LED string.

5.3 Input Capacitor Selection

The boost input current is smoothed by the boost inductor, reducing the amount of filtering necessary at the input. Some capacitance is recommended to provide decoupling from the source and to ensure that the input does not drop excessively during switching transients. Because MCP1662 is rated to work at an ambient temperature of up to 125°C, low ESR X7R ceramic capacitors are well suited since they have a low temperature coefficient and small size. For use within a limited temperature range of up to 85°C, a X5R ceramic capacitor can be used. For light load applications, 4.7 μF of capacitance is sufficient at the input. For high-power applications that have high source impedance or long leads, using a 10 μF – 20 μF input capacitor is recommended. When the device is working below a 3.0V input with high LED current, additional input capacitance can be added to provide a stable input voltage (3 x 10 μF or 33 μF) due to high input current demand. The input capacitor must be rated at a minimum of 6.3V. For MLCC ceramic capacitors and X7R or X5R capacitors, capacitance varies over the operating temperature or the DC bias range. Usually, there is a drop down to 50% of capacitance. Review the capacitor manufacturer data sheet to see how rated capacitance varies over these conditions.

Table 5-1 contains the recommended range for the input capacitor value.

5.4 Output Capacitor Selection

The output capacitor helps provide a stable output voltage and smooth load current during sudden load transients and reduces the LED current ripple. Ceramic capacitors are well suited for this application (X5R and X7R). The output capacitor ranges from 4.7 μF in case of light loads and static applications and up to 20 μF for hundreds of mA LED current applications.

As mentioned in Section 5.3, Input Capacitor Selection X7R or X5R capacitance varies over the operating temperature or the DC bias range. With a voltage applied at the maximum DC rating, capacitance might drop down to half. This might affect the stability or limit the output power. Capacitance drop over the entire temperature range is less than 20%. Users must carefully select the DC voltage rating (DCV_{RATE}) for the output capacitor according to Equations 5-3 and 5-4:

EQUATION 5-3:

$$DCV_{RATE} > ((V_{Fmax} \times nLED) + V_{FB})$$

or

EQUATION 5-4:

$$DCV_{RATE} > V_{OUTmax}$$

Table 5-1 contains the recommended range for the input and output capacitor value.

TABLE 5-1: CAPACITOR VALUE RANGE

	C_{IN}	C_{OUT}
Minimum	4.7 μF	4.7 μF
Maximum	—	47 μF

5.5 Inductor Selection

The MCP1662 device is designed to be used with small surface mount inductors; the inductance value can range from 4.7 μH to 10 μH . An inductance value of 4.7 μH is recommended for output voltages below 15V (4 or 5 LEDs in series connection). For higher output voltages, up to 32V (from 5 to maximum 10 LEDs), an inductance value of 10 μH is optimum.

TABLE 5-2: MCP1662 RECOMMENDED INDUCTORS FOR BOOST CONVERTER

Part Number	Value (μH)	DCR Ω (typ)	I_{SAT} (A)	Size WxLxH (mm)
Coilcraft				
MSS5131-472	4.7	0.038	1.42	5.1x5.1x3.1
XFL4020-472	4.7	0.057	2.7	4.2x4.2x2.1
LPS5015-562	5.6	0.175	1.6	5.0x5.0x1.5
LPS6235-103	10	0.065	1.5	6.2x6.2x3.5
XAL4040-103	10	0.084	1.9	4.3x4.3x4.1
Würth Elektronik				
744025004 Type WE-TPC	4.7	0.1	1.7	2.8x2.8x2.8
744043004 WE-TPC	4.7	0.05	1.7	4.8x4.8x2.8
744773112 WE-PD2	10	0.156	1.6	4.0x4.5x3.2
74408943100 WE-SPC	10	0.082	2.1	4.8x4.8x3.8
TDK Corporation				
B82462G4472	4.7	0.04	1.8	6.3x6.3x3.0
B82462G4103	10	0.062	1.3	6.3x6.3x3.0
VLCF4024T-4R7	4.7	0.087	1.43	4.0x4.0x2.4

Several parameters are used to select the correct inductor: maximum rated current, saturation current and copper resistance (DCR). For boost converters, the inductor current is much higher than the output current. The average inductor current is equal to the input current. The inductor's peak current is 30-40% higher than the average. The lower the inductor DCR, the higher the efficiency of the converter, a common trade-off in size versus efficiency.

Peak current is the maximum or limit value and saturation current typically specifies a point at which the inductance has rolled off a percentage of the rated value. This can range from a 20% to 40% reduction in inductance. As inductance rolls off, the inductor ripple current increases, as does the peak switch current. It is important to keep the inductance from rolling off too much, causing switch current to reach the peak limit.

5.6 Rectifier Diode Selection

Schottky diodes are used to reduce losses. The diode's average current must be higher than the maximum output current. The diode's reverse breakdown voltage must be higher than the internal switch rating voltage of 36V.

The converter's efficiency will be improved if the voltage drop across the diode is lower. The forward voltage (V_F) rating is forward-current dependent, which is equal in particular to the load current.

For high currents and high ambient temperatures, use a diode with good thermal characteristics.

TABLE 5-3: RECOMMENDED SCHOTTKY DIODES

Type	V_{OUTmax}	T_A
PMEG2005	18V	< 85°C
PMEG4005	36V	< 85°C
MBR0520	18V	< 125°C
MBR0540	36V	< 125°C

5.7 Thermal Calculations

The MCP1662 device is available in two different packages (5-lead SOT-23 and 8-lead 2x3 TDFN). By calculating the power dissipation and applying the package thermal resistance (θ_{JA}), the junction temperature is estimated. The maximum continuous junction temperature rating for the MCP1662 device is +125°C.

To quickly estimate the internal power dissipation for the switching boost regulator, an empirical calculation using measured efficiency can be used. Given the measured efficiency, the internal power dissipation is estimated by [Equation 5-5](#).

EQUATION 5-5:

$$\left(\frac{V_{\text{OUT}} \times I_{\text{OUT}}}{\text{Efficiency}} \right) - (V_{\text{OUT}} \times I_{\text{OUT}}) = P_{\text{Dis}}$$

The difference between the first term, input power, and the second term, power delivered, is the internal power dissipation of the MCP1662 device. This is an estimate, assuming that most of the power lost is internal to the MCP1662 and not C_{IN} , C_{OUT} , the rectifier diode and the inductor. There is some percentage of power lost in the boost inductor and the rectifier diode, with very little loss in the input and output capacitors. For a more accurate estimation of internal power dissipation, subtract the $I_{\text{INRMS}}^2 \times L_{\text{DCR}}$ and $I_{\text{LED}} \times V_F$ power dissipation (where I_{INRMS} is the average input current, L_{DCR} is the inductor series resistance and V_F is the diode voltage drop). Another source of loss for the LED

MCP1662

driver that is external to the MCP1662 is the sense resistor. The losses for the sense resistor can be approximated by $V_{FB} \times I_{LED}$.

5.8 PCB Layout Information

Good printed circuit board layout techniques are important to any switching circuitry, and switching power supplies are no different. When wiring the switching high-current paths, short and wide traces should be used. Therefore it is important that the input and output capacitors be placed as close as possible to the MCP1662 to minimize the loop area.

The R_{SET} resistor and feedback signal should be routed away from the switching node and the switching current loop. When possible, ground planes and traces should be used to help shield the feedback signal and minimize noise and magnetic interferences.

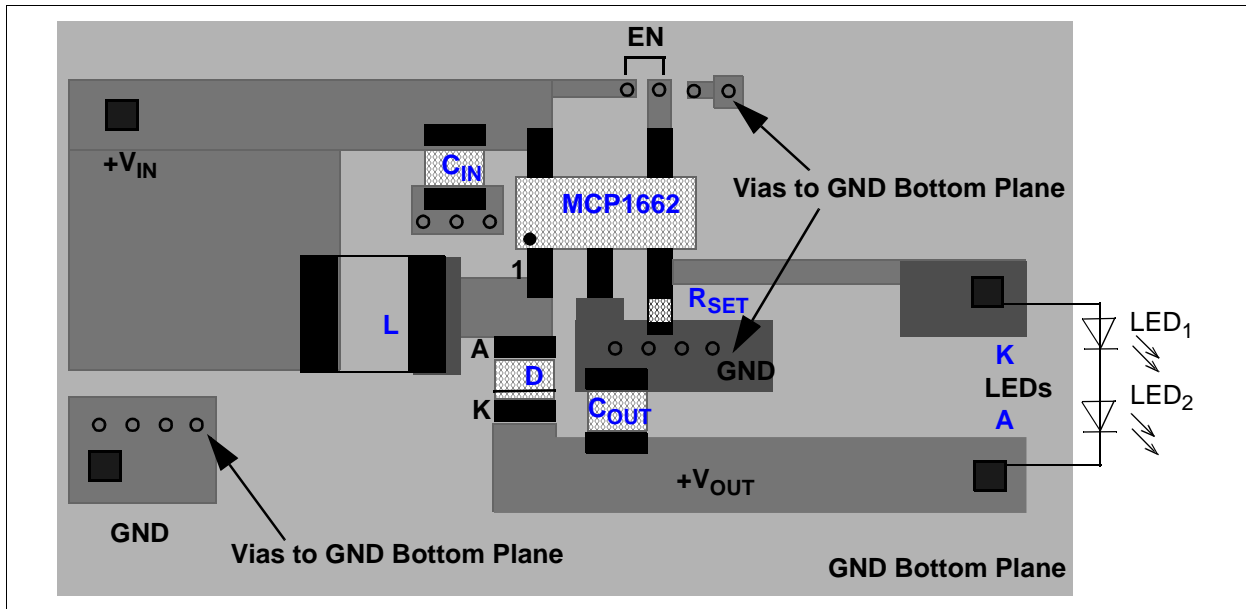

FIGURE 5-1: MCP1662 5-Lead SOT-23 Recommended Layout.

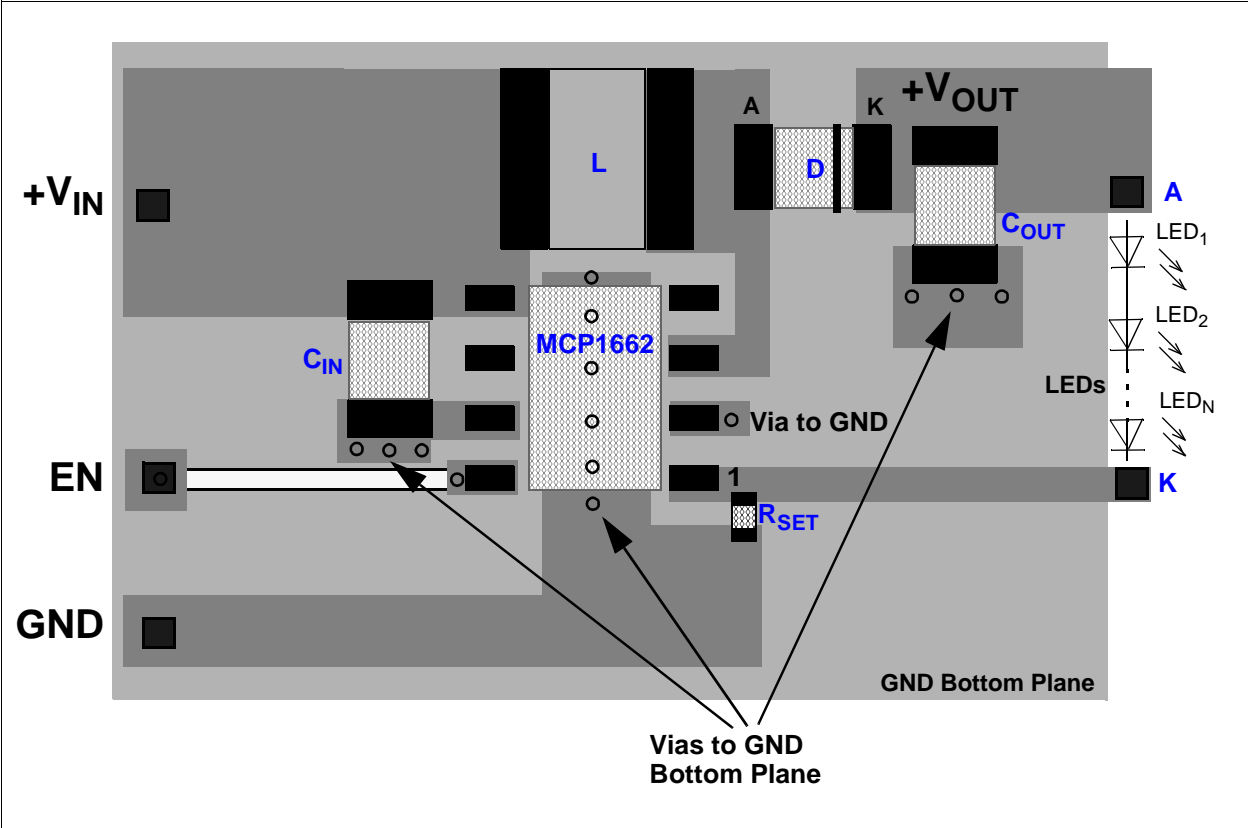

FIGURE 5-2: MCP1662 TDFN Recommended Layout.

MCP1662

NOTES:

6.0 PACKAGING INFORMATION

6.1 Package Marking Information

5-Lead SOT-23

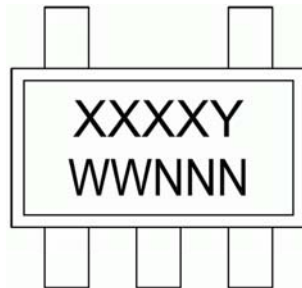

Example

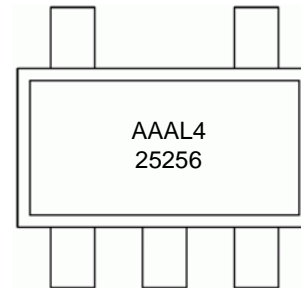

8-Lead TDFN (2x3x0.75 mm)

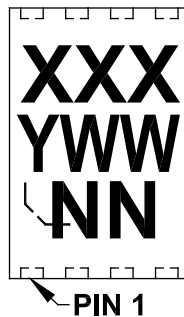

Example

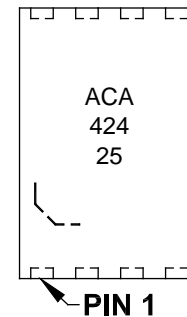

Legend:	XX...X	Customer-specific information
	Y	Year code (last digit of calendar year)
	YY	Year code (last 2 digits of calendar year)
	WW	Week code (week of January 1 is week '01')
	NNN	Alphanumeric traceability code
	(e3)	Pb-free JEDEC® designator for Matte Tin (Sn)
	*	This package is Pb-free. The Pb-free JEDEC designator (e3) can be found on the outer packaging for this package.
Note:	In the event the full Microchip part number cannot be marked on one line, it will be carried over to the next line, thus limiting the number of available characters for customer-specific information.	

MCP1662

5-Lead Plastic Small Outline Transistor (OT) [SOT-23]

Note: For the most current package drawings, please see the Microchip Packaging Specification located at <http://www.microchip.com/packaging>

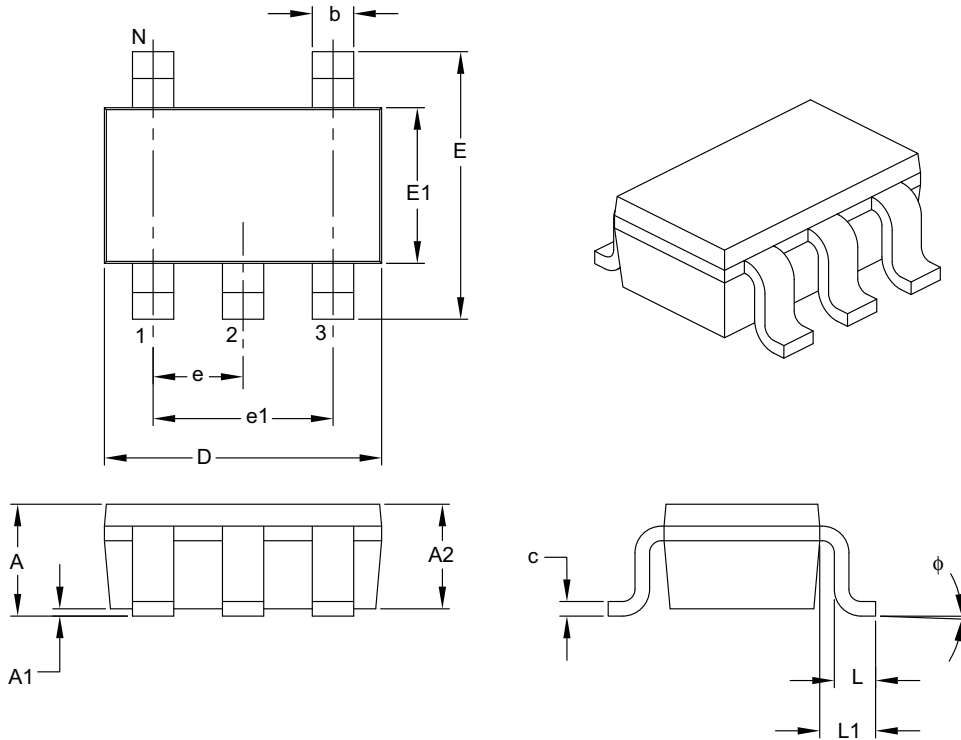

Dimension Limits	Units	MILLIMETERS		
		MIN	NOM	MAX
Number of Pins	N	5		
Lead Pitch	e	0.95 BSC		
Outside Lead Pitch	e1	1.90 BSC		
Overall Height	A	0.90	–	1.45
Molded Package Thickness	A2	0.89	–	1.30
Standoff	A1	0.00	–	0.15
Overall Width	E	2.20	–	3.20
Molded Package Width	E1	1.30	–	1.80
Overall Length	D	2.70	–	3.10
Foot Length	L	0.10	–	0.60
Footprint	L1	0.35	–	0.80
Foot Angle	ϕ	0°	–	30°
Lead Thickness	c	0.08	–	0.26
Lead Width	b	0.20	–	0.51

Notes:

- Dimensions D and E1 do not include mold flash or protrusions. Mold flash or protrusions shall not exceed 0.127 mm per side.
- Dimensioning and tolerancing per ASME Y14.5M.

BSC: Basic Dimension. Theoretically exact value shown without tolerances.

Microchip Technology Drawing C04-091B

5-Lead Plastic Small Outline Transistor (OT) [SOT-23]

Note: For the most current package drawings, please see the Microchip Packaging Specification located at <http://www.microchip.com/packaging>

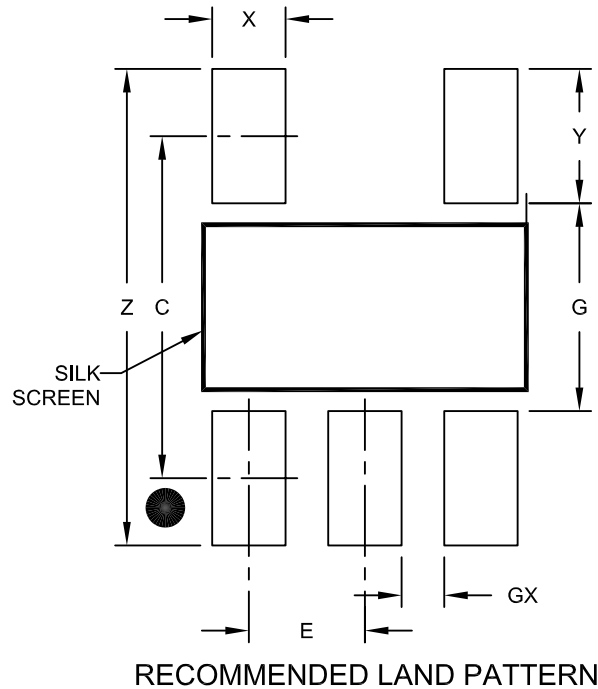

Dimension Limits	Units	MILLIMETERS		
		MIN	NOM	MAX
Contact Pitch	E	0.95 BSC		
Contact Pad Spacing	C		2.80	
Contact Pad Width (X5)	X			0.60
Contact Pad Length (X5)	Y			1.10
Distance Between Pads	G	1.70		
Distance Between Pads	GX	0.35		
Overall Width	Z			3.90

Notes:

1. Dimensioning and tolerancing per ASME Y14.5M

BSC: Basic Dimension. Theoretically exact value shown without tolerances.

Microchip Technology Drawing No. C04-2091A

MCP1662

8-Lead Plastic Dual Flat, No Lead Package (MN) – 2x3x0.75mm Body [TDFN]

Note: For the most current package drawings, please see the Microchip Packaging Specification located at <http://www.microchip.com/packaging>

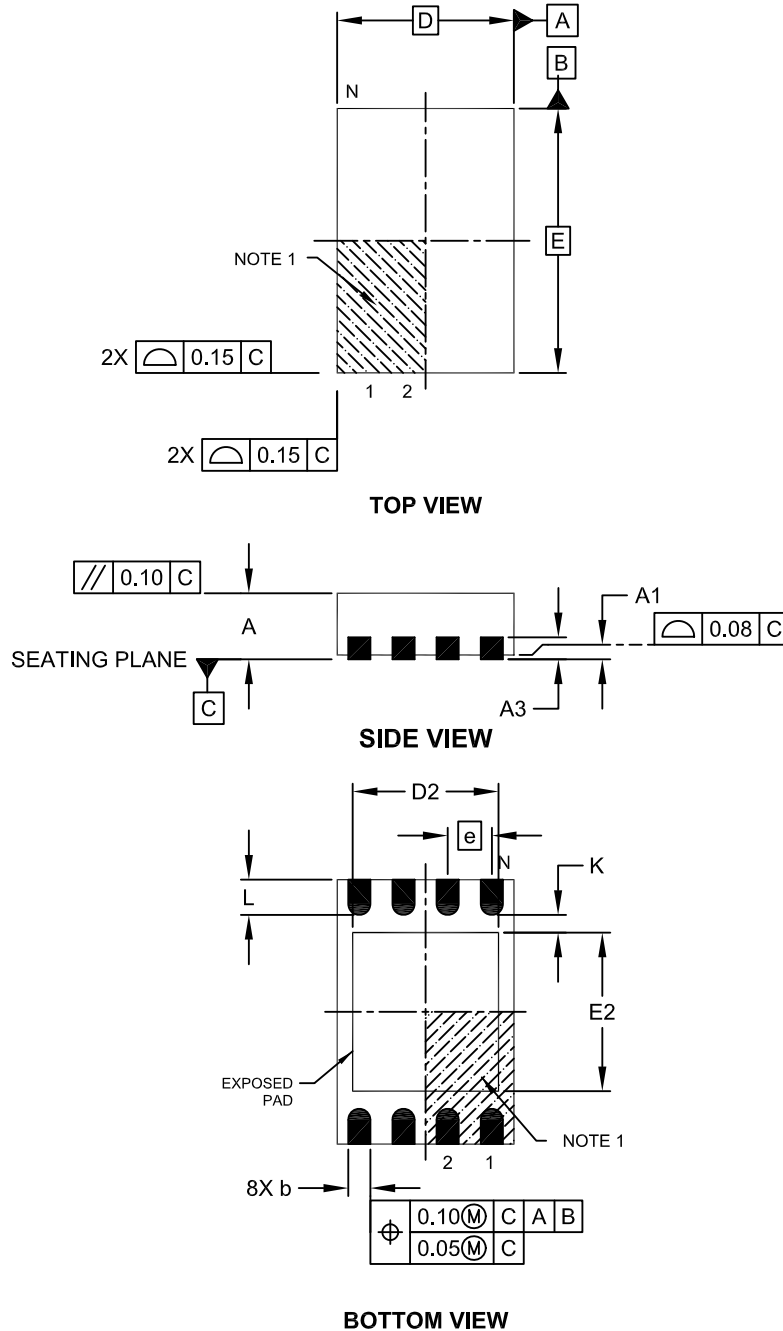

Microchip Technology Drawing No. C04-129C Sheet 1 of 2

8-Lead Plastic Dual Flat, No Lead Package (MN) – 2x3x0.75mm Body [TDFN]

Note: For the most current package drawings, please see the Microchip Packaging Specification located at <http://www.microchip.com/packaging>

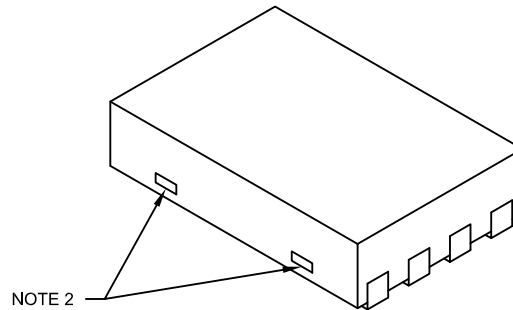

Dimension Limits	Units	MILLIMETERS		
		MIN	NOM	MAX
Number of Pins	N	8		
Pitch	e	0.50 BSC		
Overall Height	A	0.70	0.75	0.80
Standoff	A1	0.00	0.02	0.05
Contact Thickness	A3	0.20 REF		
Overall Length	D	2.00 BSC		
Overall Width	E	3.00 BSC		
Exposed Pad Length	D2	1.20	-	1.60
Exposed Pad Width	E2	1.20	-	1.60
Contact Width	b	0.20	0.25	0.30
Contact Length	L	0.25	0.30	0.45
Contact-to-Exposed Pad	K	0.20	-	-

Notes:

1. Pin 1 visual index feature may vary, but must be located within the hatched area.
2. Package may have one or more exposed tie bars at ends.
3. Package is saw singulated
4. Dimensioning and tolerancing per ASME Y14.5M

BSC: Basic Dimension. Theoretically exact value shown without tolerances.

REF: Reference Dimension, usually without tolerance, for information purposes only.

Microchip Technology Drawing No. C04-129C Sheet 2 of 2

MCP1662

8-Lead Plastic Dual Flat, No Lead Package (MN) – 2x3x0.75 mm Body [TDFN]

Note: For the most current package drawings, please see the Microchip Packaging Specification located at <http://www.microchip.com/packaging>

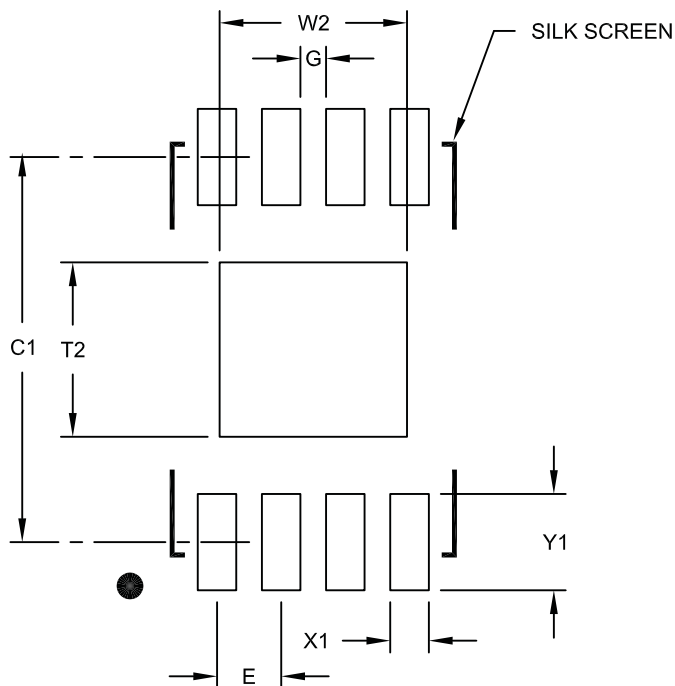

RECOMMENDED LAND PATTERN

		Units	MILLIMETERS		
Dimension Limits			MIN	NOM	MAX
Contact Pitch	E		0.50 BSC		
Optional Center Pad Width	W2				1.46
Optional Center Pad Length	T2				1.36
Contact Pad Spacing	C1			3.00	
Contact Pad Width (X8)	X1				0.30
Contact Pad Length (X8)	Y1				0.75
Distance Between Pads	G		0.20		

Notes:

1. Dimensioning and tolerancing per ASME Y14.5M

BSC: Basic Dimension. Theoretically exact value shown without tolerances.

Microchip Technology Drawing No. C04-2129A

APPENDIX A: REVISION HISTORY

Revision A (June 2014)

- Original Release of this Document.

PRODUCT IDENTIFICATION SYSTEM

To order or obtain information, e.g., on pricing or delivery, refer to the factory or the listed sales office.

<u>PART NO.</u>	X	X	<u>XX</u>
Device	Tape and Reel	Temperature Range	Package
Device:	MCP1662:	High-Voltage Step-Up LED Driver with UVLO and OLP	
Temperature Range:	E	= -40°C to +125°C (Extended)	
Package:	MNY	= Plastic Dual Flat, No Lead – 2x3x0.75 mm Body (TDFN)	
	OT	= Plastic Small Outline Transistor (SOT-23)	
	*Y	= Nickel palladium gold manufacturing designator. Only available on the TDFN package.	

Examples:

- a) MCP1662T-E/MNY: Tape and Reel, Extended temperature, 8LD TDFN package
- b) MCP1662T-E/OT: Tape and Reel, Extended temperature, 5LD SOT-23 package

Note the following details of the code protection feature on Microchip devices:

- Microchip products meet the specification contained in their particular Microchip Data Sheet.
- Microchip believes that its family of products is one of the most secure families of its kind on the market today, when used in the intended manner and under normal conditions.
- There are dishonest and possibly illegal methods used to breach the code protection feature. All of these methods, to our knowledge, require using the Microchip products in a manner outside the operating specifications contained in Microchip's Data Sheets. Most likely, the person doing so is engaged in theft of intellectual property.
- Microchip is willing to work with the customer who is concerned about the integrity of their code.
- Neither Microchip nor any other semiconductor manufacturer can guarantee the security of their code. Code protection does not mean that we are guaranteeing the product as “unbreakable.”

Code protection is constantly evolving. We at Microchip are committed to continuously improving the code protection features of our products. Attempts to break Microchip's code protection feature may be a violation of the Digital Millennium Copyright Act. If such acts allow unauthorized access to your software or other copyrighted work, you may have a right to sue for relief under that Act.

Information contained in this publication regarding device applications and the like is provided only for your convenience and may be superseded by updates. It is your responsibility to ensure that your application meets with your specifications. MICROCHIP MAKES NO REPRESENTATIONS OR WARRANTIES OF ANY KIND WHETHER EXPRESS OR IMPLIED, WRITTEN OR ORAL, STATUTORY OR OTHERWISE, RELATED TO THE INFORMATION, INCLUDING BUT NOT LIMITED TO ITS CONDITION, QUALITY, PERFORMANCE, MERCHANTABILITY OR FITNESS FOR PURPOSE. Microchip disclaims all liability arising from this information and its use. Use of Microchip devices in life support and/or safety applications is entirely at the buyer's risk, and the buyer agrees to defend, indemnify and hold harmless Microchip from any and all damages, claims, suits, or expenses resulting from such use. No licenses are conveyed, implicitly or otherwise, under any Microchip intellectual property rights.

Trademarks

The Microchip name and logo, the Microchip logo, dsPIC, FlashFlex, KEELOQ, KEELOQ logo, MPLAB, PIC, PICmicro, PICSTART, PIC³² logo, rPIC, SST, SST Logo, SuperFlash and UNI/O are registered trademarks of Microchip Technology Incorporated in the U.S.A. and other countries.

FilterLab, Hampshire, HI-TECH C, Linear Active Thermistor, MTP, SEEVAL and The Embedded Control Solutions Company are registered trademarks of Microchip Technology Incorporated in the U.S.A.

Silicon Storage Technology is a registered trademark of Microchip Technology Inc. in other countries.

Analog-for-the-Digital Age, Application Maestro, BodyCom, chipKIT, chipKIT logo, CodeGuard, dsPICDEM, dsPICDEM.net, dsPICworks, dsSPEAK, ECAN, ECONOMONITOR, FanSense, HI-TIDE, In-Circuit Serial Programming, ICSP, Mindi, MiWi, MPASM, MPF, MPLAB Certified logo, MPLIB, MPLINK, mTouch, Omniclient Code Generation, PICC, PICC-18, PICDEM, PICDEM.net, PICkit, PICtail, REAL ICE, rLAB, Select Mode, SQI, Serial Quad I/O, Total Endurance, TSHARC, UniWinDriver, WiperLock, ZENA and Z-Scale are trademarks of Microchip Technology Incorporated in the U.S.A. and other countries.

SQTP is a service mark of Microchip Technology Incorporated in the U.S.A.

GestIC and ULPP are registered trademarks of Microchip Technology Germany II GmbH & Co. KG, a subsidiary of Microchip Technology Inc., in other countries.

All other trademarks mentioned herein are property of their respective companies.

© 2014, Microchip Technology Incorporated, Printed in the U.S.A., All Rights Reserved.

 Printed on recycled paper.

ISBN: 978-1-63276-332-7

Microchip received ISO/TS-16949:2009 certification for its worldwide headquarters, design and wafer fabrication facilities in Chandler and Tempe, Arizona; Gresham, Oregon and design centers in California and India. The Company's quality system processes and procedures are for its PIC[®] MCUs and dsPIC[®] DSCs, KEELOQ[®] code hopping devices, Serial EEPROMs, microperipherals, nonvolatile memory and analog products. In addition, Microchip's quality system for the design and manufacture of development systems is ISO 9001:2000 certified.

QUALITY MANAGEMENT SYSTEM
CERTIFIED BY DNV
== ISO/TS 16949 ==



MICROCHIP

Worldwide Sales and Service

AMERICAS

Corporate Office
2355 West Chandler Blvd.
Chandler, AZ 85224-6199
Tel: 480-792-7200
Fax: 480-792-7277
Technical Support:
<http://www.microchip.com/support>
Web Address:
www.microchip.com

Atlanta
Duluth, GA
Tel: 678-957-9614
Fax: 678-957-1455

Austin, TX
Tel: 512-257-3370

Boston
Westborough, MA
Tel: 774-760-0087
Fax: 774-760-0088

Chicago
Itasca, IL
Tel: 630-285-0071
Fax: 630-285-0075

Cleveland
Independence, OH
Tel: 216-447-0464
Fax: 216-447-0643

Dallas
Addison, TX
Tel: 972-818-7423
Fax: 972-818-2924

Detroit
Novi, MI
Tel: 248-848-4000

Houston, TX
Tel: 281-894-5983

Indianapolis
Noblesville, IN
Tel: 317-773-8323
Fax: 317-773-5453

Los Angeles
Mission Viejo, CA
Tel: 949-462-9523
Fax: 949-462-9608

New York, NY
Tel: 631-435-6000

San Jose, CA
Tel: 408-735-9110

Canada - Toronto
Tel: 905-673-0699
Fax: 905-673-6509

ASIA/PACIFIC

Asia Pacific Office
Suites 3707-14, 37th Floor
Tower 6, The Gateway
Harbour City, Kowloon
Hong Kong
Tel: 852-2943-5100
Fax: 852-2401-3431

Australia - Sydney
Tel: 61-2-9868-6733
Fax: 61-2-9868-6755

China - Beijing
Tel: 86-10-8569-7000
Fax: 86-10-8528-2104

China - Chengdu
Tel: 86-28-8665-5511
Fax: 86-28-8665-7889

China - Chongqing
Tel: 86-23-8980-9588
Fax: 86-23-8980-9500

China - Hangzhou
Tel: 86-571-8792-8115
Fax: 86-571-8792-8116

China - Hong Kong SAR
Tel: 852-2943-5100
Fax: 852-2401-3431

China - Nanjing
Tel: 86-25-8473-2460
Fax: 86-25-8473-2470

China - Qingdao
Tel: 86-532-8502-7355
Fax: 86-532-8502-7205

China - Shanghai
Tel: 86-21-5407-5533
Fax: 86-21-5407-5066

China - Shenyang
Tel: 86-24-2334-2829
Fax: 86-24-2334-2393

China - Shenzhen
Tel: 86-755-8864-2200
Fax: 86-755-8203-1760

China - Wuhan
Tel: 86-27-5980-5300
Fax: 86-27-5980-5118

China - Xian
Tel: 86-29-8833-7252
Fax: 86-29-8833-7256

China - Xiamen
Tel: 86-592-2388138
Fax: 86-592-2388130

China - Zhuhai
Tel: 86-756-3210040
Fax: 86-756-3210049

ASIA/PACIFIC

India - Bangalore
Tel: 91-80-3090-4444
Fax: 91-80-3090-4123

India - New Delhi
Tel: 91-11-4160-8631
Fax: 91-11-4160-8632

India - Pune
Tel: 91-20-3019-1500

Japan - Osaka
Tel: 81-6-6152-7160
Fax: 81-6-6152-9310

Japan - Tokyo
Tel: 81-3-6880-3770
Fax: 81-3-6880-3771

Korea - Daegu
Tel: 82-53-744-4301
Fax: 82-53-744-4302

Korea - Seoul
Tel: 82-2-554-7200
Fax: 82-2-558-5932 or
82-2-558-5934

Malaysia - Kuala Lumpur
Tel: 60-3-6201-9857
Fax: 60-3-6201-9859

Malaysia - Penang
Tel: 60-4-227-8870
Fax: 60-4-227-4068

Philippines - Manila
Tel: 63-2-634-9065
Fax: 63-2-634-9069

Singapore
Tel: 65-6334-8870
Fax: 65-6334-8850

Taiwan - Hsin Chu
Tel: 886-3-5778-366
Fax: 886-3-5770-955

Taiwan - Kaohsiung
Tel: 886-7-213-7830

Taiwan - Taipei
Tel: 886-2-2508-8600
Fax: 886-2-2508-0102

Thailand - Bangkok
Tel: 66-2-694-1351
Fax: 66-2-694-1350

EUROPE

Austria - Wels
Tel: 43-7242-2244-39
Fax: 43-7242-2244-393

Denmark - Copenhagen
Tel: 45-4450-2828
Fax: 45-4485-2829

France - Paris
Tel: 33-1-69-53-63-20
Fax: 33-1-69-30-90-79

Germany - Dusseldorf
Tel: 49-2129-3766400

Germany - Munich
Tel: 49-89-627-144-0
Fax: 49-89-627-144-44

Germany - Pforzheim
Tel: 49-7231-424750

Italy - Milan
Tel: 39-0331-742611
Fax: 39-0331-466781

Italy - Venice
Tel: 39-049-7625286

Netherlands - Drunen
Tel: 31-416-690399
Fax: 31-416-690340

Poland - Warsaw
Tel: 48-22-3325737

Spain - Madrid
Tel: 34-91-708-08-90
Fax: 34-91-708-08-91

Sweden - Stockholm
Tel: 46-8-5090-4654

UK - Wokingham
Tel: 44-118-921-5800
Fax: 44-118-921-5820

03/25/14

Компания «Океан Электроники» предлагает заключение долгосрочных отношений при поставках импортных электронных компонентов на взаимовыгодных условиях!

Наши преимущества:

- Поставка оригинальных импортных электронных компонентов напрямую с производств Америки, Европы и Азии, а так же с крупнейших складов мира;
- Широкая линейка поставок активных и пассивных импортных электронных компонентов (более 30 млн. наименований);
- Поставка сложных, дефицитных, либо снятых с производства позиций;
- Оперативные сроки поставки под заказ (от 5 рабочих дней);
- Экспресс доставка в любую точку России;
- Помощь Конструкторского Отдела и консультации квалифицированных инженеров;
- Техническая поддержка проекта, помощь в подборе аналогов, поставка прототипов;
- Поставка электронных компонентов под контролем ВП;
- Система менеджмента качества сертифицирована по Международному стандарту ISO 9001;
- При необходимости вся продукция военного и аэрокосмического назначения проходит испытания и сертификацию в лаборатории (по согласованию с заказчиком);
- Поставка специализированных компонентов военного и аэрокосмического уровня качества (Xilinx, Altera, Analog Devices, Intersil, Interpoint, Microsemi, Actel, Aeroflex, Peregrine, VPT, Syfer, Eurofarad, Texas Instruments, MS Kennedy, Miteq, Cobham, E2V, MA-COM, Hittite, Mini-Circuits, General Dynamics и др.);

Компания «Океан Электроники» является официальным дистрибьютором и эксклюзивным представителем в России одного из крупнейших производителей разъемов военного и аэрокосмического назначения «JONHON», а так же официальным дистрибьютором и эксклюзивным представителем в России производителя высокотехнологичных и надежных решений для передачи СВЧ сигналов «FORSTAR».



JONHON

«JONHON» (основан в 1970 г.)

Разъемы специального, военного и аэрокосмического назначения:

(Применяются в военной, авиационной, аэрокосмической, морской, железнодорожной, горно- и нефтедобывающей отраслях промышленности)

«FORSTAR» (основан в 1998 г.)

ВЧ соединители, коаксиальные кабели, кабельные сборки и микроволновые компоненты:

(Применяются в телекоммуникациях гражданского и специального назначения, в средствах связи, РЛС, а так же военной, авиационной и аэрокосмической отраслях промышленности).



Телефон: 8 (812) 309-75-97 (многоканальный)

Факс: 8 (812) 320-03-32

Электронная почта: ocean@oceanchips.ru

Web: <http://oceanchips.ru/>

Адрес: 198099, г. Санкт-Петербург, ул. Калинина, д. 2, корп. 4, лит. А