

4A High Efficiency Switching Regulators

FEATURES

- Wide Input Voltage Range 3.5V to 30V
- Low Quiescent Current: 7mA
- Internal 4A Switch
- Very Few External Parts Required
- Self Protected Against Overloads
- Shutdown Mode Draws Only 100µA Supply Current
- Flyback Regulated Mode Has Fully Floating Outputs
- Comes in Standard 5-Pin Package
- Can Be Externally Synchronized (See LT1072 Data Sheet)

APPLICATIONS

- Boost Converter
- High Efficiency Buck Converter
- PC Power Supply with Multiple Outputs
- Battery Up-Converter
- Negative-to-Positive Converter

USER NOTE:

This data sheet is only intended to provide specifications, graphs, and a general functional description of the LT1271/LT1269. Application circuits are included to show the capability of the LT1271/LT1269. A complete design manual (AN-19) should be obtained to assist in developing new designs. This manual contains a comprehensive discussion of both the LT1070 and the external components used with it, as well as complete formulas for calculating the values of these components. The manual can also be used for the LT1271/LT1269 by factoring in the higher switch current rating and higher operating frequency.

DESCRIPTION

The LT[®]1271 and LT1269 are monolithic high power switching regulators. Identical to the popular LT1070, except for switching frequency (LT1271 = 60kHz, LT1269 = 100kHz) and slightly lower switch current, they can be operated in all standard switching configurations including buck, boost, flyback and inverting. A high current, high efficiency switch is included on the die along with all oscillator, control and protection circuitry. Integration of all functions allows the LT1271/LT1269 to be built in a standard TO-220 power package. This makes them extremely easy to use and provides "bust proof" operation similar to that obtained with 3-pin linear regulators.

The LT1271/LT1269 operate with supply voltages from 3.5V to 30V, and draw only 7mA quiescent current. By utilizing current mode switching techniques, they provide excellent AC and DC load and line regulation.

A patented adaptive antisat switch drive allows very wide ranging load currents with no loss in efficiency. An externally activated shutdown mode reduces total supply current to 100µA typical for standby operation.

LT, LTC and LT are registered trademarks of Linear Technology Corporation. Burst Mode is a trademark of Linear Technology Corporation.

TYPICAL APPLICATION

High Efficiency 5V Regulator with Burst Mode™ Operation

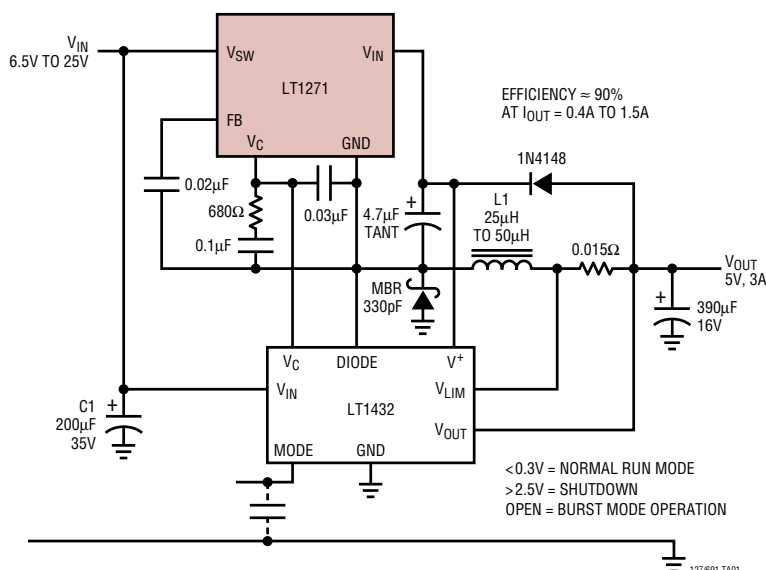

Maximum Output Power

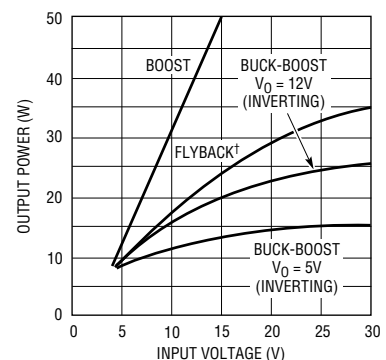

BUCK MODE OUTPUT POWER ≈ (3.5A)(V_{OUT})

†TRANSFORMER TURNS RATIO MUST BE OPTIMUM TO ACHIEVE FULL POWER.

ABSOLUTE MAXIMUM RATINGS

Supply Voltage	30V	Operating Junction Temperature Range	
Switch Output Voltage	60V	Operating	0°C to 100°C
Feedback Pin Voltage (Transient, 1ms)	±15V	Short Circuit	0°C to 125°C
Storage Temperature Range	-65°C to 150°C	Lead Temperature (Soldering, 10 sec.)	300°C

PACKAGE/ORDER INFORMATION

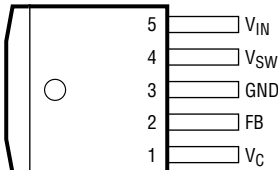
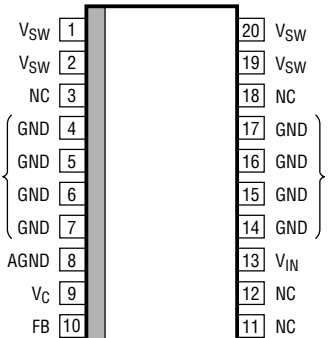
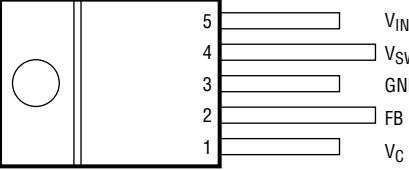
<p>FRONT VIEW</p>  <p>Q PACKAGE 5-LEAD PLASTIC DD $T_{J\text{ MAX}} = 100^{\circ}\text{C}$, $\theta_{\text{JC}} = 4^{\circ}\text{C/W}$, $\theta_{\text{JA}} = 30^{\circ}\text{C/W}^*$</p>	<p>ORDER PART NUMBER</p> <p>LT1271CQ LT1269CQ</p>	<p>TOP VIEW</p>  <p>SW PACKAGE 20-LEAD PLASTIC WIDE SO</p> <p>θ WILL VARY FROM APPROXIMATELY 40°C/W WITH 0.75 SQ. IN. OF 1 OZ. COPPER TO 46°C/W WITH 0.33 SQ. IN. OF 1 OZ. COPPER</p>	<p>ORDER PART NUMBER</p> <p>LT1269CS</p>
<p>FRONT VIEW</p>  <p>T PACKAGE 5-LEAD PLASTIC TO-220 $T_{J\text{ MAX}} = 100^{\circ}\text{C}$, $\theta_{\text{JC}} = 4^{\circ}\text{C/W}$, $\theta_{\text{JA}} = 50^{\circ}\text{C/W}^*$</p>	<p>ORDER PART NUMBER</p> <p>LT1271CT LT1269CT</p>		

*With device soldered to 1/2 square inch of 1oz copper over backside or internal layer ground plane. Consult factory for Industrial and Military grade parts.

ELECTRICAL CHARACTERISTICS $V_{\text{IN}} = 15\text{V}$, $V_{\text{C}} = 0.5\text{V}$, $V_{\text{FB}} = V_{\text{REF}}$, switch pin open, unless otherwise noted.

SYMBOL	PARAMETER	CONDITIONS	MIN	TYP	MAX	UNITS
V_{REF}	Reference Voltage	Measured at Feedback Pin	1.224	1.244	1.264	V
		$V_{\text{C}} = 0.8\text{V}$	1.214	1.244	1.274	V
I_{B}	Feedback Input Current	$V_{\text{FB}} = V_{\text{REF}}$		350	750	nA
					1100	nA
g_{m}	Error Amplifier Transconductance	$\Delta I_{\text{C}} = \pm 25\mu\text{A}$		3000	4400	μmho
				2400	7000	μmho
	Error Amplifier Source or Sink Current	$V_{\text{C}} = 1.5\text{V}$		150	200	μA
				120	400	μA
	Error Amplifier Clamp Voltage	Hi Clamp, $V_{\text{FB}} = 1\text{V}$	1.8		2.3	V
		Lo Clamp, $V_{\text{FB}} = 1.5\text{V}$	0.25	0.38	0.52	V
	Reference Voltage Line Regulation	$3\text{V} \leq V_{\text{IN}} \leq V_{\text{MAX}}$, $V_{\text{C}} = 0.8\text{V}$			0.03	%/V
A_{V}	Error Amplifier Voltage Gain	$0.9\text{V} \leq V_{\text{C}} \leq 1.4\text{V}$	500	800		V/V
	Minimum Input Voltage (Note 3)			2.8	3.0	V
I_{Q}	Supply Current	$3\text{V} \leq V_{\text{IN}} \leq V_{\text{MAX}}$, $V_{\text{C}} = 0.6\text{V}$		7	10	mA

ELECTRICAL CHARACTERISTICS $V_{IN} = 15V$, $V_C = 0.5V$, $V_{FB} = V_{REF}$, switch pin open, unless otherwise noted.

SYMBOL	PARAMETER	CONDITIONS		MIN	TYP	MAX	UNITS	
	Control Pin Threshold	Duty Cycle = 0	●	0.7 0.5	0.9	1.08 1.25	V V	
	Normal/Flyback Threshold on Feedback Pin			0.4	0.45	0.54	V	
V_{FB}	Flyback Reference Voltage	$I_{FB} = 50\mu A$	●	15 14	16.3	17.6 18	V V	
V_{FB}	Change in Flyback Reference Voltage	$0.05 \leq I_{FB} \leq 1mA$		4.5	6.8	8.5	V	
	Flyback Reference Voltage Line Regulation	$I_{FB} = 50\mu A$ $3V \leq V_{IN} \leq V_{MAX}$			0.01	0.03	%/V	
	Flyback Amplifier Transconductance (gm)	$\Delta I_C = \pm 10\mu A$		150	300	650	μmho	
	Flyback Amplifier Source and Sink Current	$V_C = 0.6V$ $I_{FB} = 50\mu A$	Source Sink	● ●	15 25	32 40	70 70	μA μA
BV	Output Switch Breakdown Voltage	$3V \leq V_{IN} \leq V_{MAX}$ $I_{SW} = 1.5mA$	●	60	75		V	
V_{SAT}	Output Switch (Note 1) "On" Resistance		●		0.2	0.33	Ω	
	Control Voltage to Switch Current Transconductance				6.4		A/V	
I_{LIM}	Switch Current Limit (Note 2)	Duty Cycle = 50% Duty Cycle = 80%	● ●	4 3.2		8 8	A A	
$\frac{\Delta I_{IN}}{\Delta I_{SW}}$	Supply Current Increase During Switch On-Time				25	40	mA/A	
f	Switching Frequency	LT1271 LT1269	● ●	50 85	60 100	70 115	kHz kHz	
DC (max)	Maximum Switch Duty Cycle	LT1271 LT1269		85 80	92 90	95 95	% %	
	Flyback Sense Delay Time				1.5		μs	
	Shutdown Mode Supply Current	$3V \leq V_{IN} \leq V_{MAX}$, $V_C = 0.05V$			100	400	μA	
	Shutdown Mode Threshold Voltage	$3V \leq V_{IN} \leq V_{MAX}$	●	100 50	150	250 300	mV mV	

The ● denotes the specifications which apply over the full operating temperature range.

Note 1: Measured with V_C in hi clamp, $V_{FB} = 0.8V$.

Note 2: For duty cycles (DC) between 50% and 85%, minimum guaranteed switch current is given by $I_{LIM} = 2.67 (2 - DC)$.

Note 3: Minimum input voltage.

TYPICAL PERFORMANCE CHARACTERISTICS

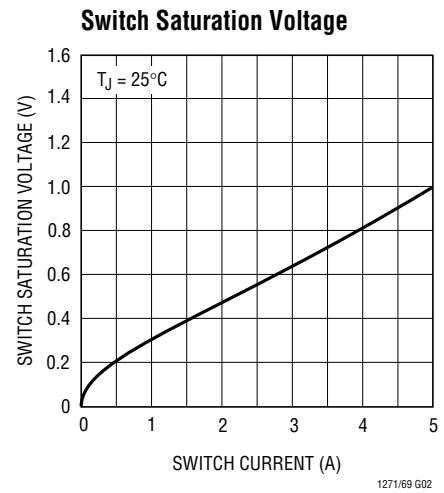
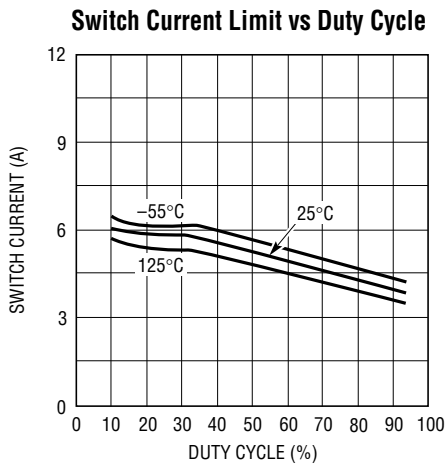

TYPICAL APPLICATIONS

Negative-to-Positive Buck-Boost Converter

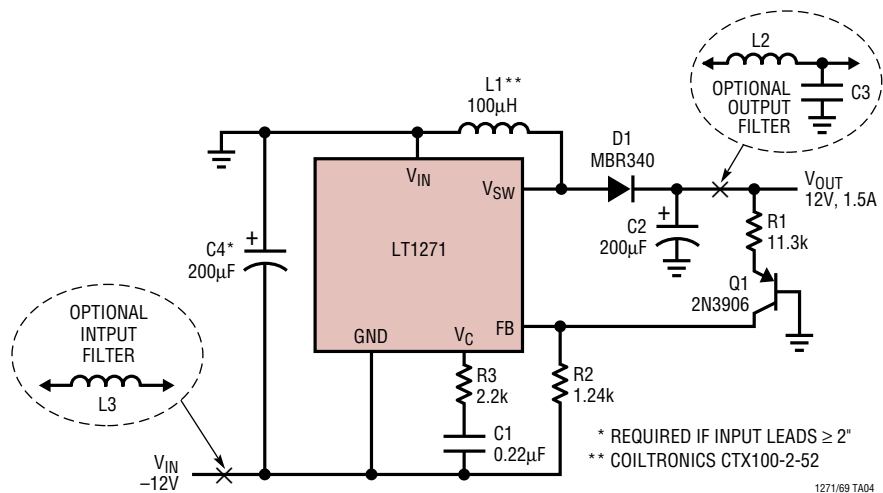

TYPICAL APPLICATIONS

Boost Converter (5V to 12V)

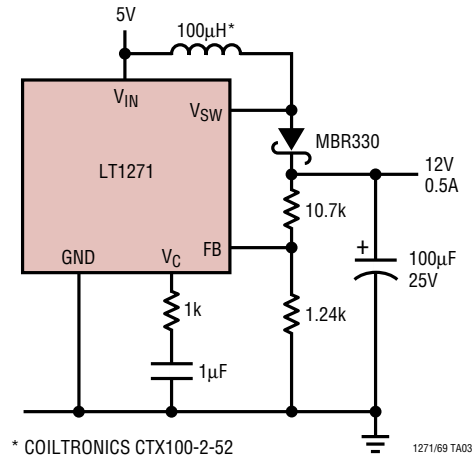

PACKAGE DESCRIPTION Dimensions in inches (millimeters) unless otherwise noted.

Q Package
5-Lead Plastic DD Pak
 (LTC DWG # 05-08-1461)

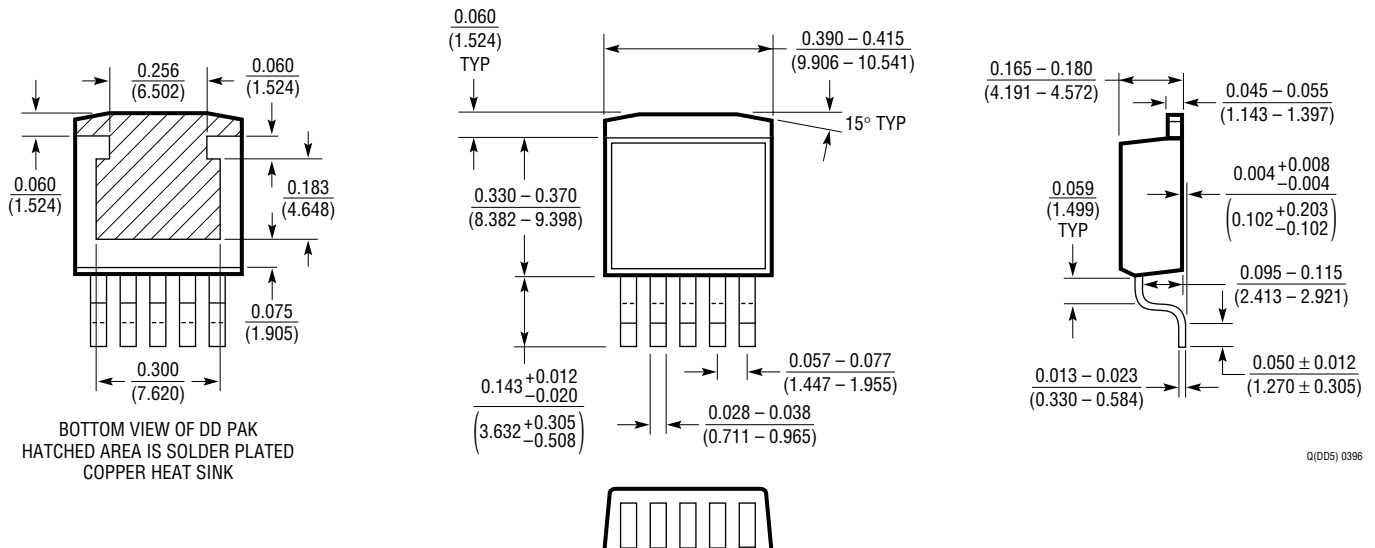

PACKAGE DESCRIPTION Dimensions in inches (millimeters) unless otherwise noted.

T Package
5-Lead Plastic TO-220 (Standard)
 (LTC DWG # 05-08-1421)

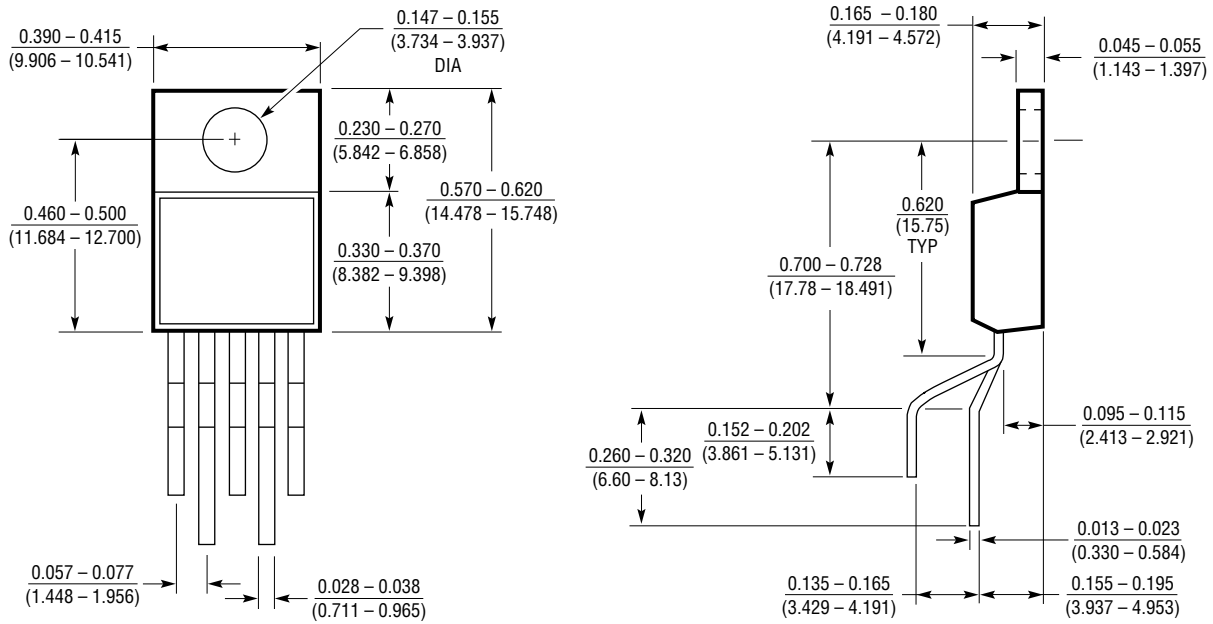

T5 (TO-220) 0398

PACKAGE DESCRIPTION Dimensions in inches (millimeters) unless otherwise noted.

SW Package
20-Lead Plastic Small Outline (Wide 0.300)
 (LTC DWG # 05-08-1620)

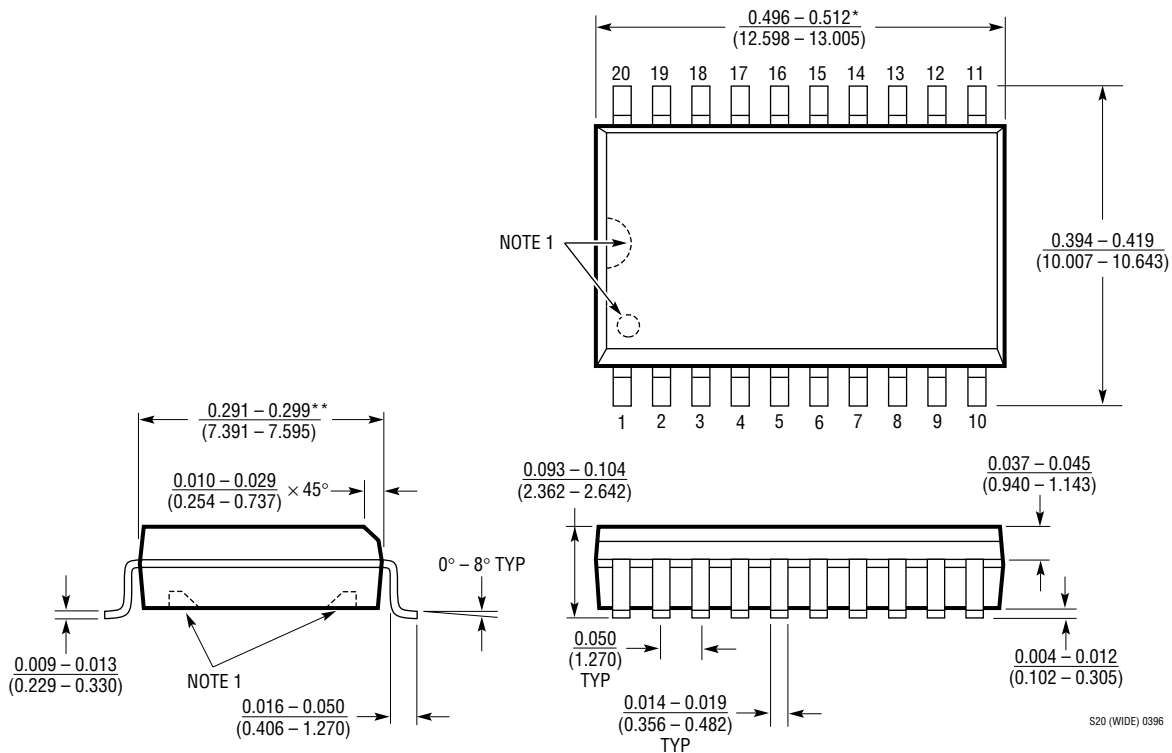

NOTE:

1. PIN 1 IDENT, NOTCH ON TOP AND CAVITIES ON THE BOTTOM OF PACKAGES ARE THE MANUFACTURING OPTIONS. THE PART MAY BE SUPPLIED WITH OR WITHOUT ANY OF THE OPTIONS

*DIMENSION DOES NOT INCLUDE MOLD FLASH. MOLD FLASH SHALL NOT EXCEED 0.006" (0.152mm) PER SIDE

**DIMENSION DOES NOT INCLUDE INTERLEAD FLASH. INTERLEAD FLASH SHALL NOT EXCEED 0.010" (0.254mm) PER SIDE

S20 (WIDE) 0396

TYPICAL APPLICATION

Negative Buck Converter

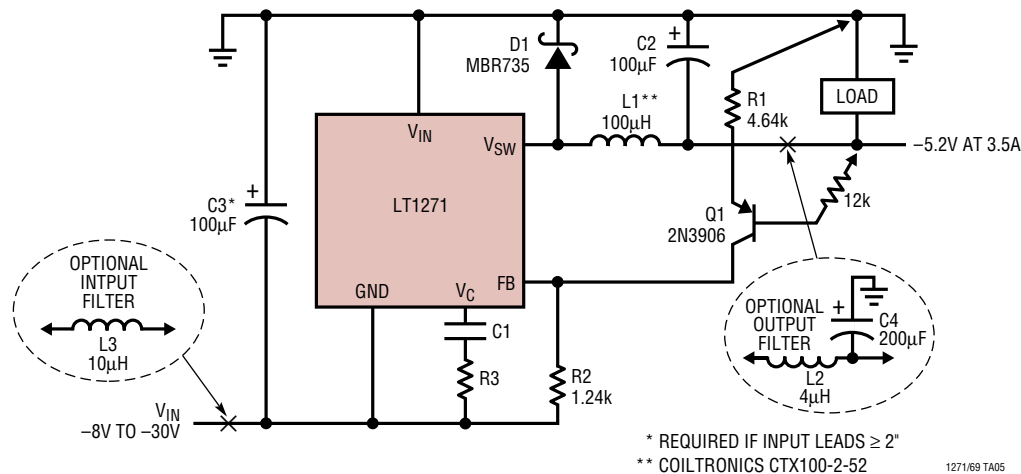

RELATED PARTS

PART NUMBER	DESCRIPTION	COMMENTS
LT1171	100kHz, 2.5A Boost Switching Regulator	Good for V_{IN} Up to 40V
LT1370	500kHz, 6A Boost Switching Regulator	6A, 42V Internal Switch
LT1371	500kHz, 3A Boost Switching Regulator	3A, 42V Internal Switch, 90% Efficiency
LT1372	500kHz, 1.5A Boost Switching Regulator	Also Regulates Negative Flyback Outputs
LT1374	500kHz, 4.5A Buck Switching Regulator	V_{IN} Up to 25V, SO-8 Package
LT1376	500kHz, 1.5A Buck Switching Regulator	V_{IN} Up to 25V, Uses 4.7µH Inductor

Компания «Океан Электроники» предлагает заключение долгосрочных отношений при поставках импортных электронных компонентов на взаимовыгодных условиях!

Наши преимущества:

- Поставка оригинальных импортных электронных компонентов напрямую с производств Америки, Европы и Азии, а так же с крупнейших складов мира;
- Широкая линейка поставок активных и пассивных импортных электронных компонентов (более 30 млн. наименований);
- Поставка сложных, дефицитных, либо снятых с производства позиций;
- Оперативные сроки поставки под заказ (от 5 рабочих дней);
- Экспресс доставка в любую точку России;
- Помощь Конструкторского Отдела и консультации квалифицированных инженеров;
- Техническая поддержка проекта, помощь в подборе аналогов, поставка прототипов;
- Поставка электронных компонентов под контролем ВП;
- Система менеджмента качества сертифицирована по Международному стандарту ISO 9001;
- При необходимости вся продукция военного и аэрокосмического назначения проходит испытания и сертификацию в лаборатории (по согласованию с заказчиком);
- Поставка специализированных компонентов военного и аэрокосмического уровня качества (Xilinx, Altera, Analog Devices, Intersil, Interpoint, Microsemi, Actel, Aeroflex, Peregrine, VPT, Syfer, Eurofarad, Texas Instruments, MS Kennedy, Miteq, Cobham, E2V, MA-COM, Hittite, Mini-Circuits, General Dynamics и др.);

Компания «Океан Электроники» является официальным дистрибьютором и эксклюзивным представителем в России одного из крупнейших производителей разъемов военного и аэрокосмического назначения «JONHON», а так же официальным дистрибьютором и эксклюзивным представителем в России производителя высокотехнологичных и надежных решений для передачи СВЧ сигналов «FORSTAR».



JONHON

«JONHON» (основан в 1970 г.)

Разъемы специального, военного и аэрокосмического назначения:

(Применяются в военной, авиационной, аэрокосмической, морской, железнодорожной, горно- и нефтедобывающей отраслях промышленности)

«FORSTAR» (основан в 1998 г.)

ВЧ соединители, коаксиальные кабели, кабельные сборки и микроволновые компоненты:

(Применяются в телекоммуникациях гражданского и специального назначения, в средствах связи, РЛС, а так же военной, авиационной и аэрокосмической отраслях промышленности).



Телефон: 8 (812) 309-75-97 (многоканальный)

Факс: 8 (812) 320-03-32

Электронная почта: ocean@oceanchips.ru

Web: <http://oceanchips.ru/>

Адрес: 198099, г. Санкт-Петербург, ул. Калинина, д. 2, корп. 4, лит. А