



Future Technology Devices International Ltd

USB to RS422 Serial Converter Cable

CE FC

Datasheet

Document Reference No.: FT_000116

Version 1.2

Issue Date: 18-01-2010

Future Technology Devices International Limited (FTDI)

Unit1, 2 Seaward Place, Centurion Business Park,, Glasgow G41 1HH United Kingdom

Tel.: +44 (0) 141 429 2777 Fax: + 44 (0) 141 429 2758

E-Mail (Support): support1@ftdichip.com Web: <http://www.ftdichip.com>

Copyright © 2010 Future Technology Devices International Limited

Neither the whole nor any part of the information contained in, or the product described in this manual, may be adapted or reproduced in any material or electronic form without the prior written consent of the copyright holder. This product and its documentation are supplied on an as-is basis and no warranty as to their suitability for any particular purpose is either made or implied. Future Technology Devices International Ltd will not accept any claim for damages howsoever arising as a result of use or failure of this product. Your statutory rights are not affected. This product or any variant of it is not intended for use in any medical appliance, device or system in which the failure of the product might reasonably be expected to result in personal injury. This document provides preliminary information that may be subject to change without notice. No freedom to use patents or other intellectual property rights is implied by the publication of this document. Future Technology Devices International Ltd, Unit1, 2 Seaward Place, Centurion Business Park, Glasgow, G41 1HH, United Kingdom. Scotland Registered Number: SC136640

1 Description

The **USB-RS422** cable is a USB to RS422 levels serial UART converter cable incorporating FTDI's FT232RQ USB to serial UART interface IC device which handles all the USB signalling and protocols. The cable provides a fast, simple way to connect devices with a RS422 interface to USB.

Each USB-RS422 cable contains a small internal electronic circuit board, utilising the FT232R, which is encapsulated into the USB connector end of the cable. The FT232R datasheet, [DS_FT232R](http://www.ftdichip.com), is available at <http://www.ftdichip.com>. The integrated electronics also include the RS422 transceiver plus Tx and Rx LEDs which give a visual indication of traffic on the cable (if transparent USB connector mould specified).

The other end of the cable is bare, tinned wire ended connections by default, but can be customised using different connectors to support various applications.

Cables are FCC, CE, RoHS compliant.

The USB side of the cable is USB powered and USB 2.0 full speed compatible. Each cable is 1.8m long and supports a data transfer rate up to 3 Mbaud. Each cable supports the FTDIChip-ID™, with a unique USB serial number programmed into the FT232R. This feature can be used to create a security or password protected file transfer access using the cable. Further information and examples on this feature are available at <http://www.ftdichip.com> under [FTDIChip-ID Projects](#).

The USB-RS422 cables require USB drivers, available free from <http://www.ftdichip.com>, which are used to make the FT232R in the cable appear as a virtual COM port (VCP). This then allows the user to communicate with the USB interface via a standard PC serial emulation port (for example TTY). Another FTDI USB driver, the D2XX driver, can also be used with application software to directly access the FT232R on the cable though a DLL. This is illustrated in the Figure 1.1

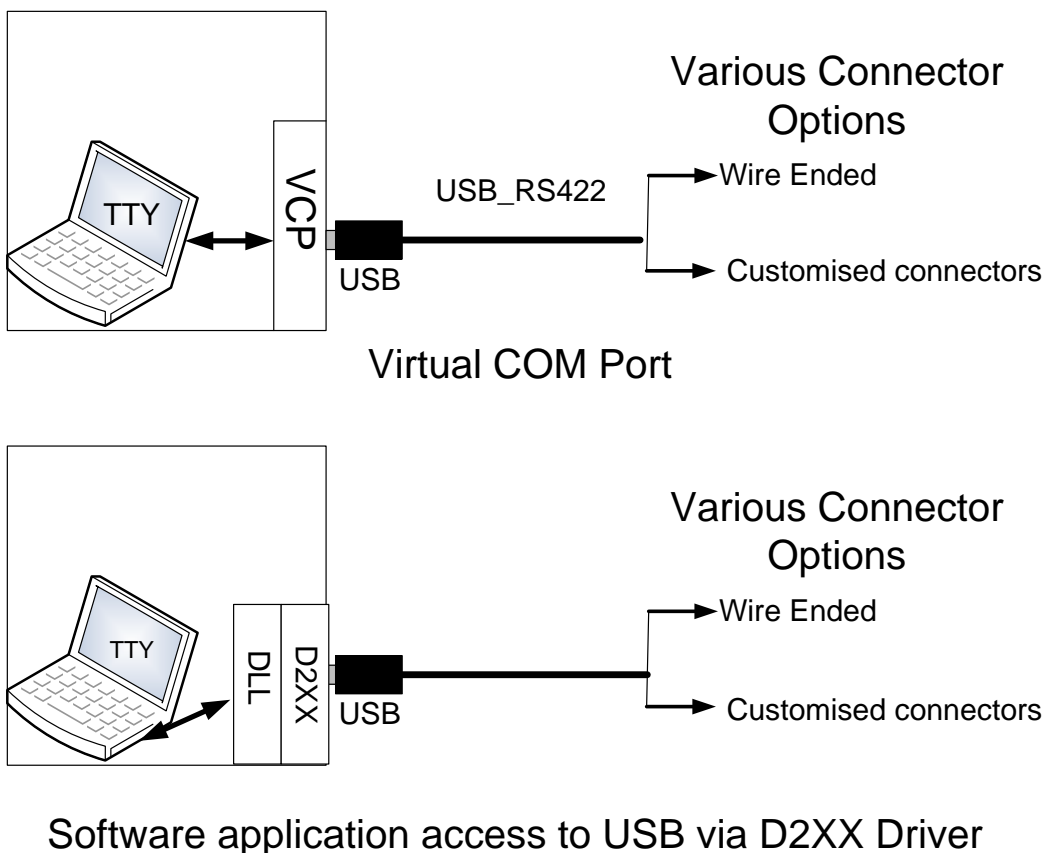

Figure 1.1 Using the USB-RS422 Cable

2 Cable Part Numbers

The following table gives details of the available USB-RS422 cables.

Table 2.1 Available USB-RS422 cables.

Part Number	Description	End Connector*	Cable details
USB-RS422-WE-1800-BT	USB to UART cable with RS422 level UART signals. B lack cable, T ransparent USB connector	Wire Ended (no connector)	1.8m cable, 9 core, UL2464 24 AWG, diam=5mm
* USB-RS422-CC-LLLL-CU	USB to UART cable with RS422 level UART signals. C = cable colour (B black or T transparent), U = USB connector colour (T transparent or B black)	CC = Connector description.	LLLL = Length of cable.

Table 2.1 USB-RS422 Cables Descriptions and Part Numbers

* FTDI supports customised end connector designs. For more information, please contact FTDI Sales Team (sales1@ftdichip.com)

2.1 Certifications

FTDI USB-RS422 cable is fully RoHs compliant as well as CE and FCC certified.



Table of Contents

1	Description	1
2	Cable Part Numbers.....	2
2.1	Certifications.....	2
3	Typical Applications.....	4
3.1	Driver Support	4
3.2	Features.....	5
4	Features of FT232R applicable to USB-RS422 Cable	6
5	USB-RS422-WE-LLLL-CU.....	7
5.1	USB-RS422-WE Connections and Mechanical Details.....	7
5.2	USB-RS422-WE Cable Signal Descriptions.....	8
5.3	USB-RS422-WE Electrical Parameters	8
6	Cable PCB Block Diagram.....	10
7	USB-RS422 Schematic	11
8	Contact Information	12
	Appendix A - Cable EEPROM Configuration.....	14
	Appendix B - List of Figures and Tables.....	15
	Appendix C - Revision History	16

3 Typical Applications

- USB to serial RS422 level converter.
- Upgrading legacy peripherals to USB.
- Interface Microcontroller UART or I/O to USB.
- Interface FPGA or PLD to USB.
- USB Instrumentation PC interface.
- USB industrial control.
- USB password protected file transfers.

3.1 Driver Support

Royalty free VIRTUAL COM PORT (VCP) DRIVERS for...

- Windows 7 64-bit
- Windows 98, 98SE, ME, 2000, Server 2003, and Server 2008
- Windows XP and XP 64-bit
- Windows Vista and Vista 64-bit
- Windows XP Embedded
- Windows CE 4.2, 5.0 and 6.0
- Mac OS 8/9, OS-X
- Linux 2.4 and greater

Royalty free D2XX Direct Drivers (USB Drivers + DLL S/W Interface)

- Windows 7 64-bit
- Windows 98, 98SE, ME, 2000, Server 2003, and Server 2008
- Windows XP and XP 64-bit
- Windows Vista and Vista 64-bit
- Windows XP Embedded
- Windows CE 4.2, 5.0 and 6.0
- Linux 2.4 and greater
- Mac OS-X

The drivers listed above are all available to download for free from www.ftdichip.com. Various 3rd Party Drivers are also available for other operating systems - see www.ftdichip.com for details.

3.2 Features

- USB-RS422 converter cable provides a USB to RS422 serial interface with customised end connectors.
- Entire USB protocol handled by the electronics in the cable.
- EIA/TIA-422 communication interface with low power requirements.
- UART interface support for 7 or 8 data bits, 1 or 2 stop bits and odd / even / mark / space / no parity.
- Internal EEPROM with user writeable area.
- FTDI's royalty-free VCP allow for communication as a standard emulated COM port and D2XX 'direct' drivers provide DLL application programming interface.
- Visual indication of Tx and Rx traffic via LEDs in the transparent USB connector.
- X-On / X-Off software handshaking.
- Data transfer rates from 300 baud to 3 Mbaud.
- Support for FT232R FTDIChip-ID™ feature for improved security.
- Low USB bandwidth consumption.
- UHCI / OHCI / EHCI host controller compatible.
- USB 2.0 Full Speed compatible.
- -40°C to +85°C operating temperature range.
- Cable length is 1.80m (6 feet).
- ESD Protection for RS-422 I/O's
 - ±15kV Human Body Model (HBM)
 - ±15kV EN61000-4-2 Air Gap Discharge
 - ±8kV EN61000-4-2 Contact Discharge
- FCC and CE compliant.
- Custom versions available on request (subject to MOQ).
- RoHS Compliant

4 Features of FT232R applicable to USB-RS422 Cable

The USB-RS422 cable uses FTDI's FT232RQ USB to serial UART IC device. This section summarises the key features of the FT232RQ which apply to the USB-RS422 USB to serial RS422 converter cables. For further details, and a full features and enhancements description consult the FT232R datasheet. This is available from www.ftdichip.com.

Internal EEPROM. The internal EEPROM in each cable is used to store USB Vendor ID (VID), Product ID (PID), device serial number, product description string and various other USB configuration descriptors. Each cable is supplied with the internal EEPROM pre-programmed as described in **Appendix A – Cable EEPROM Configuration**. The internal EEPROM descriptors can be programmed in circuit, over USB without any additional voltage requirement. It can be programmed using the FTDI utility software called MPROG, which can be downloaded from FTDI Utilities on the FTDI website (www.ftdichip.com). Additionally, there is a user area of the internal EEPROM available to system designers to allow storing of data (note that this is not modified by MPROG).

Lower Operating and Suspend Current. The FT232R has a low 15mA operating supply current and a very low USB suspend current of approximately 70µA. (Note that during suspend mode, the current drawn by any customised cable application which uses the USB supply, should not exceed 2.5mA to remain USB compliant)

Low USB Bandwidth Consumption. The USB interface of the FT232R, and therefore the USB-RS422 cables has been designed to use as little as possible of the total USB bandwidth available from the USB host controller.

FTDICHIP-ID™. The FT232R includes the new FTDICHIP-ID™ security dongle feature. This FTDICHIP-ID™ feature allows a unique number to be burnt into each cable during manufacture. This number cannot be reprogrammed. This number is only readable over USB can be used to form the basis of a security dongle which can be used to protect any customer application software being copied. This allows the possibility of using the USB-RS422 cables as a dongle for software licensing. Further to this, a renewable license scheme can be implemented based on the FTDICHIP-ID™ number when encrypted with other information. This encrypted number can be stored in the user area of the FT232R internal EEPROM, and can be decrypted, then compared with the protected FTDICHIP-ID™ to verify that a license is valid. Web based applications can be used to maintain product licensing this way. An application note, AN232R-02, available from FTDI website (www.ftdichip.com) describes this feature.

Improved EMI Performance. The USB-RS422 cables are FCC and CE certified.

Extended Operating Temperature Range - The USB-RS422 cables are capable of operating over an extended temperature range of -40° to +85° C thus allowing them to be used in commercial or industrial applications.

5 USB-RS422-WE-LLLL-CU

The USB-RS422-WE cable is un-terminated; it has bare and tinned wires.

The LLLL specifies the length of the cable in cm. The CU specifies the colour of the cable and the colour of the USB connector. The cable can be either Black or transparent. The USB connector comes with transparent plug because of the LED implemented inside but can be sold in black colour as well. For simplicity, the LLLL and CU have been dropped from the following descriptions.

5.1 USB-RS422-WE Connections and Mechanical Details

The following Figure 5.1 shows the cable signals and the wire colours for the signals on the USB-RS422-WE cable. The Figure 5.2 shows dimensions in millimetres.

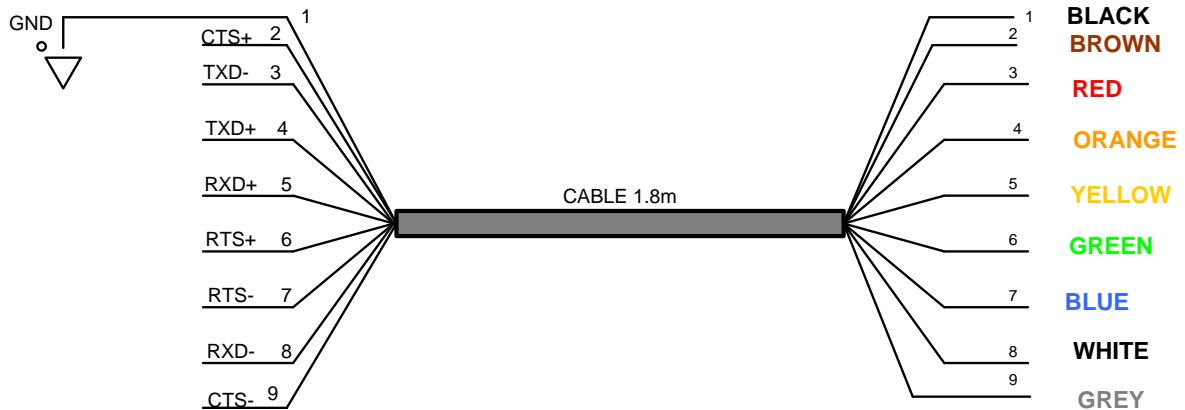

Figure 5.1 USB-RS422-WE Connections

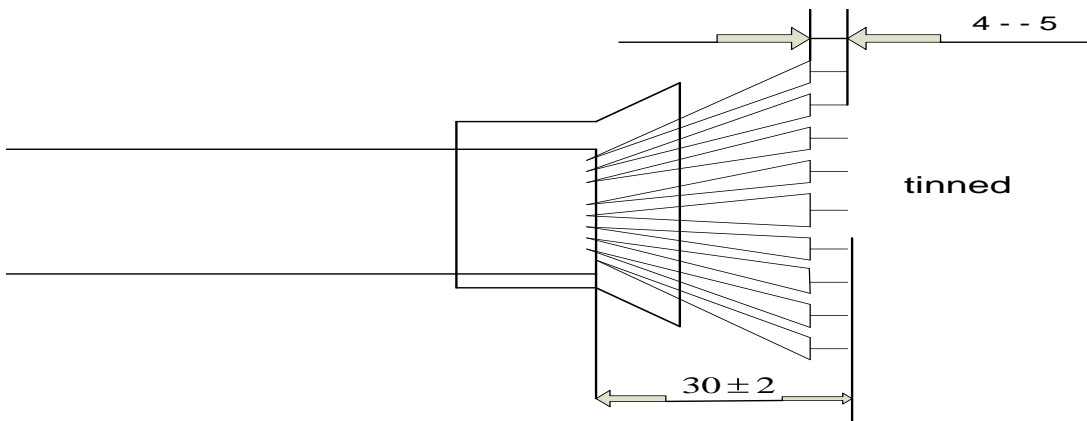

Figure 5.2 USB-RS422-WE Mechanical Details (dimensions in mm)



Figure 5.3 USB-RS422-WE Cable images

5.2 USB-RS422-WE Cable Signal Descriptions

Colour	Name	Type	Description
Black	GND	GND	Device ground supply pin.
Brown	CTS+	Input	Clear to Send Control + (B), Input
Red	TXD-	Output	Data - (A) Output
Orange	TXD+	Output	Data + (B) Output
Yellow	RXD+	Input	Data + (B) Input
Green	RTS+	Output	Request To Send Control + (B), Output
Blue	RTS-	Output	Request To Send Control - (A), Output
White	RXD-	Input	Data - (A) Input
Grey	CTS-	Input	Clear to Send Control input - (A), Input

Table 5.1 USB-RS422-WE Cable Signal Descriptions

5.3 USB-RS422-WE Electrical Parameters

Parameter	Description	Minimum	Typical	Maximum	Units	Conditions
Receiver Input						
VCM	Common-mode input voltage range	-7		+12	V	
IN	Input Current			1.0	mA	VIN = +12V
				-0.8		VIN = -7V
VTH	Differential Threshold Voltage, VTH	-0.2		+0.2	V	
VIHYS	Input Hysteresis		20		mV	
RIN	Input Resistance, RIN	12	15		kΩ	
Transmitter Output						
VOD	Differential Output Voltage, dVOD	1.5		5	V	With RL = 54Ω. CL = 50pF *

Table 5.2 USB-RS422-WE I/O Characteristics

* - The 54 ohms is the equivalent of two 120 ohm termination resistors placed on each side of the transmission line and the input impedance of 32 receivers on the line.

Description	Conditions	Minimum	Typical	Maximum
ESD HBM	RS-422 Inputs and Outputs		±15 kV	
EN61000-4-2ContactDischarge	RS-422 Inputs and Outputs		±8 kV	
EN61000-4-2AirGapDischarge	RS-422 Inputs and Outputs		±15 kV	

Table 5.3 USB-RS422-WE ESD Tolerance

6 Cable PCB Block Diagram

The block diagram for the small internal electronic circuit board, utilising the FTDI FT232R, which is encapsulated into the USB connector end of the cable, is shown in Figure 6.1.

Customised versions of the cable are also available. Users interested in customised versions of these cables should contact FTDI sales (sales1@ftdichip.com).

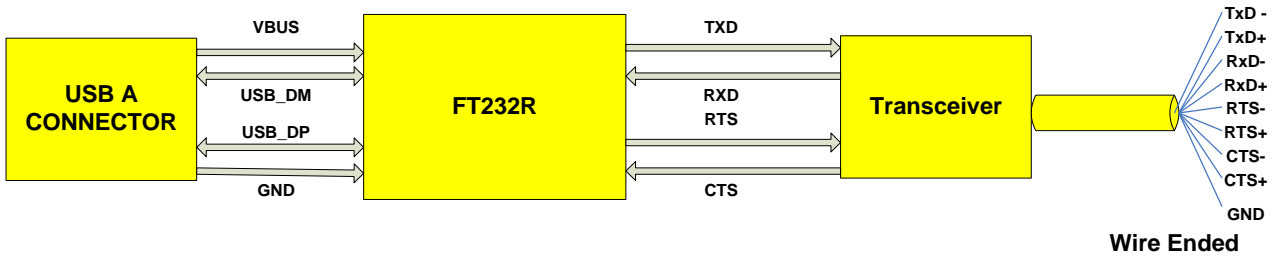

Figure 6.1 Block diagram of PCB Used in the USB to RS422 Serial Converter Cable

8 Contact Information

Head Office – Glasgow, UK

Future Technology Devices International Limited
Unit 1, 2 Seaward Place, Centurion Business Park
Glasgow G41 1HH
United Kingdom
Tel: +44 (0) 141 429 2777
Fax: +44 (0) 141 429 2758

Tel: +44 (0) 141 429 2777
Fax: +44 (0) 141 429 2758

E-mail (Sales) sales1@ftdichip.com
E-mail (Support) support1@ftdichip.com
E-mail (General Enquiries) admin1@ftdichip.com
Web Site URL <http://www.ftdichip.com>
Web Shop URL <http://www.ftdichip.com>

Branch Office – Shanghai, China

Future Technology Devices International Limited (China)
Room 408, 317 Xianxia Road,
ChangNing District,
ShangHai, China

Tel: +86 (21) 62351596
Fax: +86(21) 62351595

E-Mail (Sales): cn.sales@ftdichip.com
E-Mail (Support): cn.support@ftdichip.com
E-Mail (General Enquiries): cn.admin1@ftdichip.com
Web Site URL: <http://www.ftdichip.com>

Branch Office – Taipei, Taiwan

Future Technology Devices International Limited (Taiwan)
2F, No. 516, Sec. 1, NeiHu Road
Taipei 114
Taiwan , R.O.C.
Tel: +886 (0) 2 8791 3570
Fax: +886 (0) 2 8791 3576

E-mail (Sales) tw.sales1@ftdichip.com
E-mail (Support) tw.support1@ftdichip.com
E-mail (General Enquiries) tw.admin1@ftdichip.com
Web Site URL <http://www.ftdichip.com>

Branch Office – Hillsboro, Oregon, USA

Future Technology Devices International Limited (USA)
7235 NW Evergreen Parkway, Suite 600
Hillsboro, OR 97123-5803
USA
Tel: +1 (503) 547 0988
Fax: +1 (503) 547 0987

E-Mail (Sales) us.sales@ftdichip.com
E-Mail (Support) us.admin@ftdichip.com
Web Site URL <http://www.ftdichip.com>

Distributor and Sales Representatives

Please visit the Sales Network page of the FTDI Web site for the contact details of our distributor(s) and sales representative(s) in your country.

Vinculum is part of Future Technology Devices International Ltd. Neither the whole nor any part of the information contained in, or the product described in this manual, may be adapted or reproduced in any material or electronic form without the prior written consent of the copyright holder. This product and its documentation are supplied on an as-is basis and no warranty as to their suitability for any particular purpose is either made or implied. Future Technology Devices International Ltd will not accept any claim for damages howsoever arising as a result of use or failure of this product. Your statutory rights are not affected. This product or any variant of it is not intended for use in any medical appliance, device or system in which the failure of the product might reasonably be expected to result in personal injury. This document provides preliminary information that may be subject to change without notice. No freedom to use patents or other intellectual property rights is implied by the publication of this document. Future Technology Devices International Ltd, Unit 1, 2 Seaward Place, Centurion Business Park, Glasgow G41 1HH United Kingdom. Scotland Registered Number: SC136640

Appendix A - Cable EEPROM Configuration

Each USB-RS422 cable is controlled by the FTDI FT232R IC. This FT232R device contains an EEPROM which contains the USB configuration descriptors for that device. When the cable is plugged into a PC or a USB reset is performed, the PC will read these descriptors. The default values stored into the internal EEPROM are defined in Table 0.1

Parameter	Value	Notes
USB Vendor ID (VID)	0403h	FTDI default VID (hex)
USB Product ID (PID)	6001h	FTDI default PID (hex)
Serial Number Enabled?	Yes	
Serial Number	See Note	A unique serial number is generated and programmed into the EEPROM during device final test.
Pull down I/O Pins in USB Suspend	Disabled	Enabling this option will make the device pull down on the UART interface lines when the power is shut off (PWREN# is high).
Manufacturer Name	FTDI	
Product Description	See note	USB-RS422-WE
Max Bus Power Current	90mA	
Power Source	Bus Powered	
Device Type	FT232R	
USB Version	0200	Returns USB 2.0 device description to the host. Note: The device is a USB 2.0 Full Speed device (12Mb/s) as opposed to a USB 2.0 High Speed device (480Mb/s).
Remote Wake Up	Disabled	
High Current I/Os	Enabled	Enables the high drive level on the UART and CBUS I/O pins.
Load VCP Driver	Enabled	Makes the device load the VCP driver interface for the device.
Invert TXD	Disabled	Signal on this pin becomes TXD# if enable.
Invert RXD	Disabled	Signal on this pin becomes RXD# if enable.
Invert RTS#	Disabled	Signal on this pin becomes RTS if enable.
Invert CTS#	Disabled	Signal on this pin becomes CTS if enable.

Table 0.1 Default Internal EEPROM Configuration

The internal EEPROM in the cable can be re-programmed over USB using the utility program MPROG. MPROG can be downloaded from the www.ftdichip.com. Version 2.8a or later is required for the FT232R chip. Users who do not have their own USB Vendor ID but who would like to use a unique Product ID in their design can apply to FTDI for a free block of unique PIDs. Contact FTDI support for this service.

Appendix B - List of Figures and Tables

List of Figures

Figure 1.1 Using the USB-RS422 Cable.....	1
Figure 5.1 USB-RS422-WE Connections	7
Figure 5.2 USB-RS422-WE Mechanical Details (dimensions in mm)	7
Figure 5.3 USB-RS422-WE Cable images.....	7
Figure 6.1 Block diagram of PCB Used in the USB to RS422 Serial Converter Cable	10
Figure 7.1 Schematic for USB-RS422 Converter Cable	11

List of Tables

Table 2.1 USB-RS422 Cables Descriptions and Part Numbers.....	2
Table 5.1 USB-RS422-WE Cable Signal Descriptions.....	8
Table 5.2 USB-RS422-WE I/O Characteristics	8
Table 5.3 USB-RS422-WE ESD Tolerance	9
Table 0.1 Default Internal EEPROM Configuration.....	14

Appendix C - Revision History

Version Draft	First Draft	Jan 2009
Version 1.0		11 th Feb 2009
Version 1.1	Added and corrected images	14 th May 2009
Version 1.2	Changed TT to BT (Transparent to Black cable). Added Window 7 support	18 th January 2010

Компания «Океан Электроники» предлагает заключение долгосрочных отношений при поставках импортных электронных компонентов на взаимовыгодных условиях!

Наши преимущества:

- Поставка оригинальных импортных электронных компонентов напрямую с производств Америки, Европы и Азии, а так же с крупнейших складов мира;
- Широкая линейка поставок активных и пассивных импортных электронных компонентов (более 30 млн. наименований);
- Поставка сложных, дефицитных, либо снятых с производства позиций;
- Оперативные сроки поставки под заказ (от 5 рабочих дней);
- Экспресс доставка в любую точку России;
- Помощь Конструкторского Отдела и консультации квалифицированных инженеров;
- Техническая поддержка проекта, помощь в подборе аналогов, поставка прототипов;
- Поставка электронных компонентов под контролем ВП;
- Система менеджмента качества сертифицирована по Международному стандарту ISO 9001;
- При необходимости вся продукция военного и аэрокосмического назначения проходит испытания и сертификацию в лаборатории (по согласованию с заказчиком);
- Поставка специализированных компонентов военного и аэрокосмического уровня качества (Xilinx, Altera, Analog Devices, Intersil, Interpoint, Microsemi, Actel, Aeroflex, Peregrine, VPT, Syfer, Eurofarad, Texas Instruments, MS Kennedy, Miteq, Cobham, E2V, MA-COM, Hittite, Mini-Circuits, General Dynamics и др.);

Компания «Океан Электроники» является официальным дистрибьютором и эксклюзивным представителем в России одного из крупнейших производителей разъемов военного и аэрокосмического назначения «JONHON», а так же официальным дистрибьютором и эксклюзивным представителем в России производителя высокотехнологичных и надежных решений для передачи СВЧ сигналов «FORSTAR».



JONHON

«JONHON» (основан в 1970 г.)

Разъемы специального, военного и аэрокосмического назначения:

(Применяются в военной, авиационной, аэрокосмической, морской, железнодорожной, горно- и нефтедобывающей отраслях промышленности)

«FORSTAR» (основан в 1998 г.)

ВЧ соединители, коаксиальные кабели, кабельные сборки и микроволновые компоненты:

(Применяются в телекоммуникациях гражданского и специального назначения, в средствах связи, РЛС, а так же военной, авиационной и аэрокосмической отраслях промышленности).



Телефон: 8 (812) 309-75-97 (многоканальный)

Факс: 8 (812) 320-03-32

Электронная почта: ocean@oceanchips.ru

Web: <http://oceanchips.ru/>

Адрес: 198099, г. Санкт-Петербург, ул. Калинина, д. 2, корп. 4, лит. А