

**NOTE**

All numerical values are in metric units [with U.S. customary units in brackets]. Dimensions are in millimeters. Unless otherwise specified, dimensions have a tolerance of  $\pm 0.13$  mm and angles have a tolerance of  $\pm 2^\circ$ . Figures and illustrations are for identification only and are not drawn to scale.

## 1. INTRODUCTION

This specification covers the requirements for application of NECTOR S Bus Bar Connectors. These connectors provide a branch circuit tap into two conductor cord type power cables. This bus bar connector accepts a NECTOR S plug to distribute power to lamps or other accessories.

When corresponding with TE Connectivity Personnel, use the terminology provided in this specification to facilitate inquiries for information. Basic terms and features of this product are provided in Figure 1.

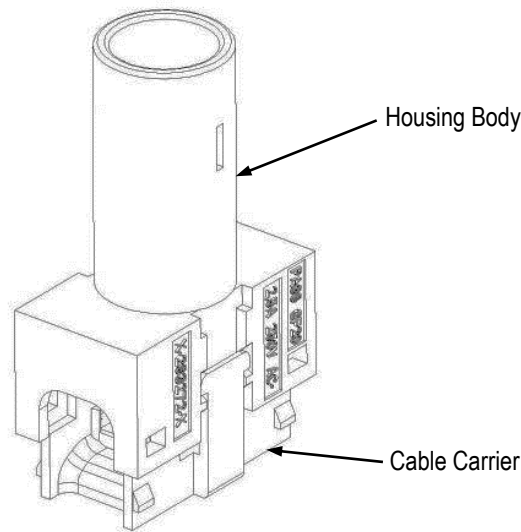

Figure 1

## 2. REFERENCE MATERIAL

### 2.1. Revision Summary

- Updated document to corporate requirements
- New layout and format
- New information for North America merged with European information throughout document

### 2.2. Customer Assistance

Reference Product Base Part Numbers 293270, 293300, and 2213222 and Product Codes K746 and L764 show the variations available for keying, mounting flange (tab), end vs. thru type, and sealing. Use of these numbers will identify the product line and help you to obtain product and tooling information. Such information can be obtained through a local TE Representative, by visiting our website at [www.te.com](http://www.te.com), or by calling PRODUCT INFORMATION or the TOOLING ASSISTANCE CENTER at the numbers at the bottom of this page.

### 2.3. Drawings

Customer Drawings for product part numbers are available from our website at [www.te.com](http://www.te.com). If there is a conflict between the information contained in the Customer Drawings and this specification or with any other technical documentation supplied, the information contained in the Customer Drawings takes priority.

## 2.4. Specifications

Product Specifications [108-20294](#) (North American version), and [108-94018](#) (European version), provides product performance and test results for the NECTOR S Connectors.

## 2.5. Instructional Material

Instruction sheets provide product assembly instructions or tool setup and operation procedures. Instruction sheets available that pertain to this product are:

- [411-18493](#) (Operating Instructions for Bus Bar Hand Tool 8-528441-7)
- [408-32179](#) (NECTOR S Bus Bar Connector)

## 3. REQUIREMENTS

### 3.1. Safety

Do not stack product shipping containers so high that the containers buckle or deform.

### 3.2. Storage

#### A. Ultraviolet Light

Prolonged exposure to ultraviolet light may deteriorate the chemical composition used in the product material.

#### B. Shelf Life

The product should remain in the shipping containers until ready for use to prevent deformation to components. The product should be used on a first in, first out basis to avoid storage contamination that could adversely affect performance.

#### C. Chemical Exposure

Do not store product near any chemical listed below as they may cause stress corrosion cracking in the material.

Alkalies	Ammonia	Citrates	Phosphates	Citrates	Sulfur Compounds
Amines	Carbonates	Nitrites	Sulfur Nitrites		Tartrates

### 3.3. Wire Selection and Preparation

These connectors will accept cables provided in the table in Figure 2. No preparation of the cables is required.

PART NUMBER SERIES	APPLICABLE CABLE
293270-[]	H03VVH2-F, 2 x 0.75 mm <sup>2</sup>
293300-[]	
2213222-[]	SPT-2, 2/C 18 AWG Stranded

Figure 2

### 3.4. Termination Requirements

#### A. Cable Termination to NECTOR S Bus Bar Connectors



#### CAUTION

The cable carrier must always be gently pried off. Do NOT push the wire to be terminated through the opening of the connector body and cable carrier in the pre-staged position, otherwise damage may occur.

Two small screwdrivers can be used to gently pry the locking tabs of the cable carrier away to remove the cable carrier from the housing body. Care must be taken to avoid damaging the tabs on the cable carrier. See Figure 3.

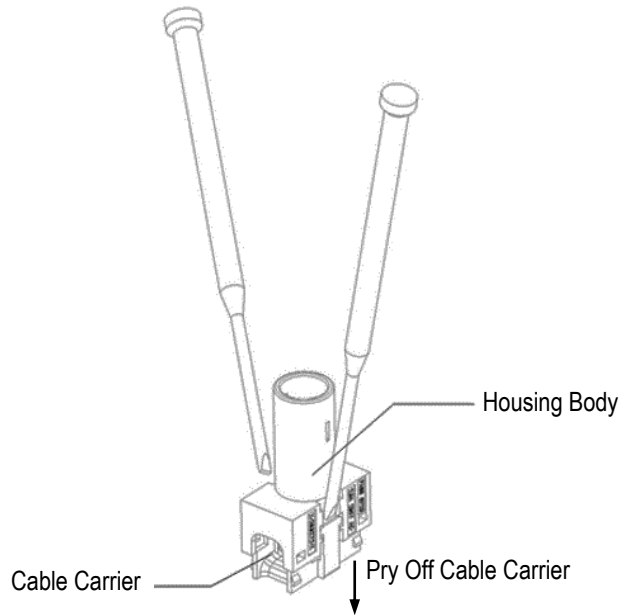

Figure 3

### B. Positioning the Cable

Lay the cable to be tapped into the channel of the cable carrier.



**CAUTION**

*Make sure that the cable is resting FLAT inside the channel to ensure the termination is successful. See Figure 4.*

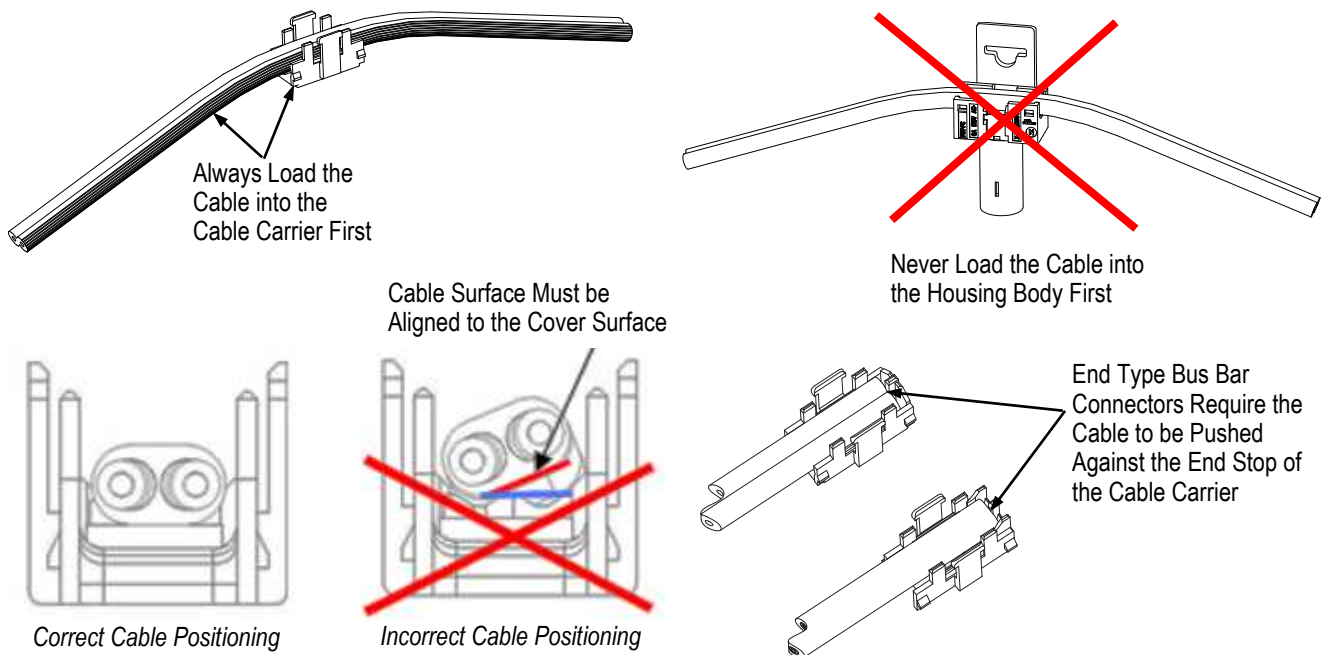

Figure 4

### C. Housing Body

Install the housing body onto the cable carrier with the cable between the two parts until the locking tabs on the cable carrier engage with the locking ramp features on the housing body in the pre-stage position. See Figure 5.



**CAUTION**

Always note cable polarity conventions when placing the cable carrier into the pre-staged position. The striped/ribbed side of the cable is normally placed on the Neutral (N) or Negative (-) side of the bus bar connector.

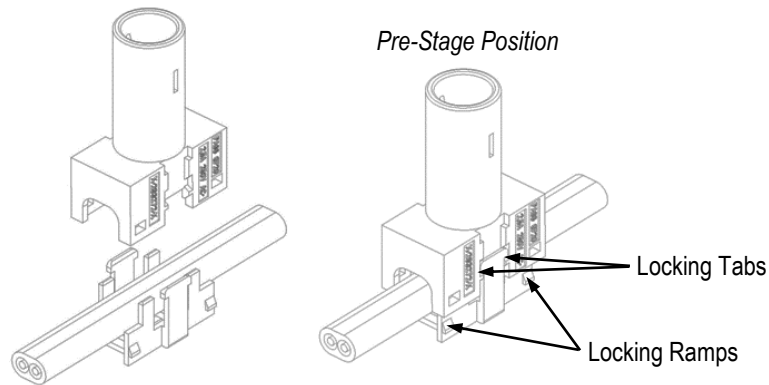
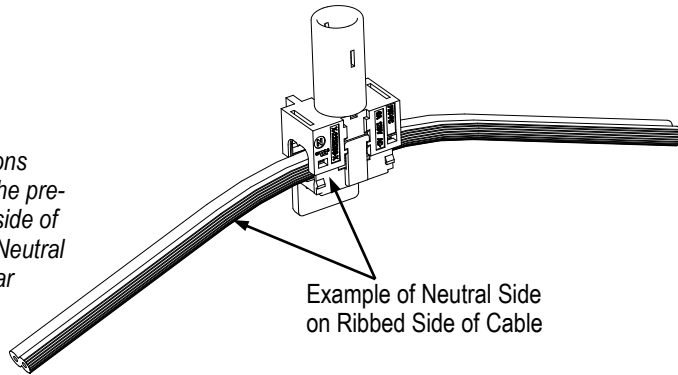

**NOTE**

Keep the cable flat in the cable carrier during this step.

Figure 5

**D. Connector Termination**



**NOTE**

Pre-form the cable to fit into the cable support feature while ensuring the cable remains flat in the cable carrier.

The cable to be terminated must be routed through the support features in the hand tool to ensure a good termination. Then, place the pre-staged connector into the TE hand tool (p/n 8-528441-7) and squeeze the handles fully to terminate the connector onto the cable. The handle on the tool must be fully depressed to release and remove the terminated connector assembly. See Figure 6.

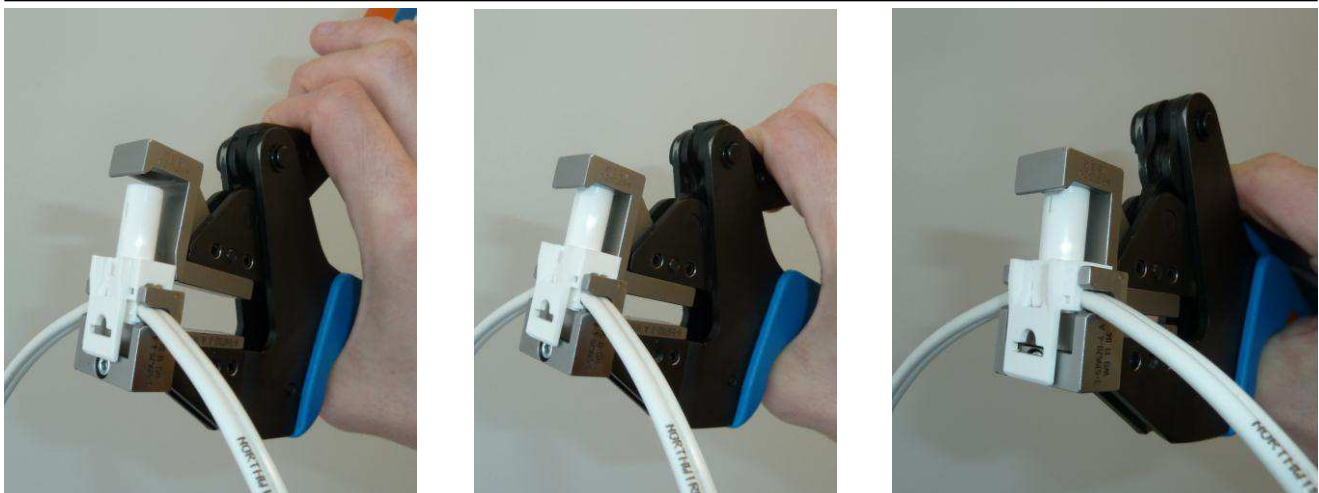
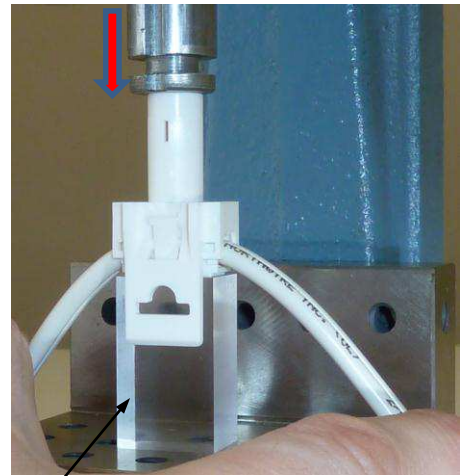
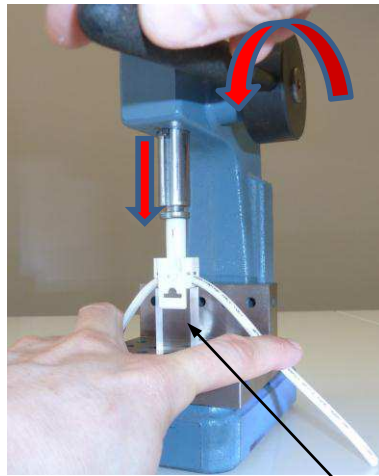

Figure 6

**CAUTION**

Terminating the NECTOR S Bus Bar connector with tooling other than the recommended TE hand tool can result in improperly terminated connectors. Additional details on the hand tool are available in Instruction Sheet 411-18493. If the TE hand tool is not used, the termination must be done using a tool with a parallel type action (an arbor press for example). When a non-TE tool is used to terminate this product, it is important to hold the cable flat in the cable carrier, while terminating. After termination, the latching features must be inspected to ensure that all latches on both sides of the bus bar connector are fully seated. This product cannot be properly terminated using standard single pivot type hand pliers. See Figure 7.

**Arbor Press Termination**

20-25 mm [.750-1.00 in.]  
Wide Support Block Used  
to Form Cable so it is  
Held in the Cable Carrier  
During Termination

Figure 7

**E. Termination Inspection**

Inspect the terminated connector to ensure all of the latch features on the connector housing body and cable carrier are fully seated. Verify the cable is flat in the termination area. A terminated connector assembly is not designed to be repaired. If the connector features are not properly seated or damaged, the connector must be removed and replaced with a newly terminated connector. See Figure 8.

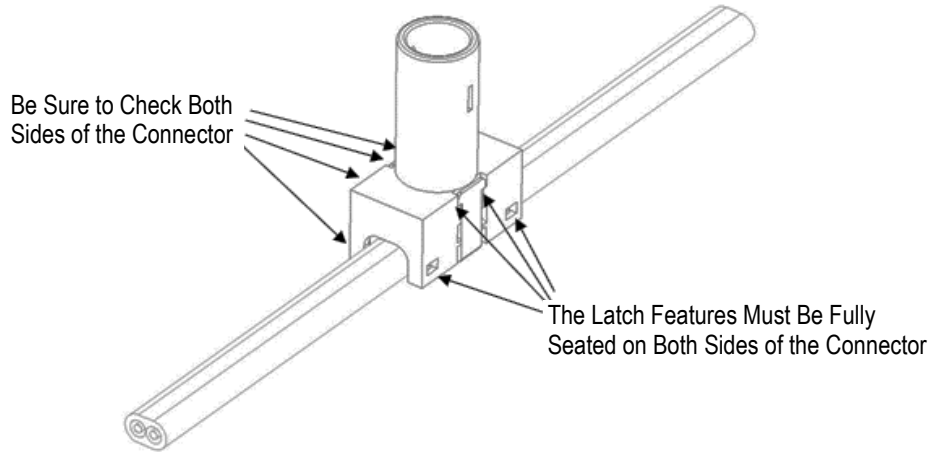
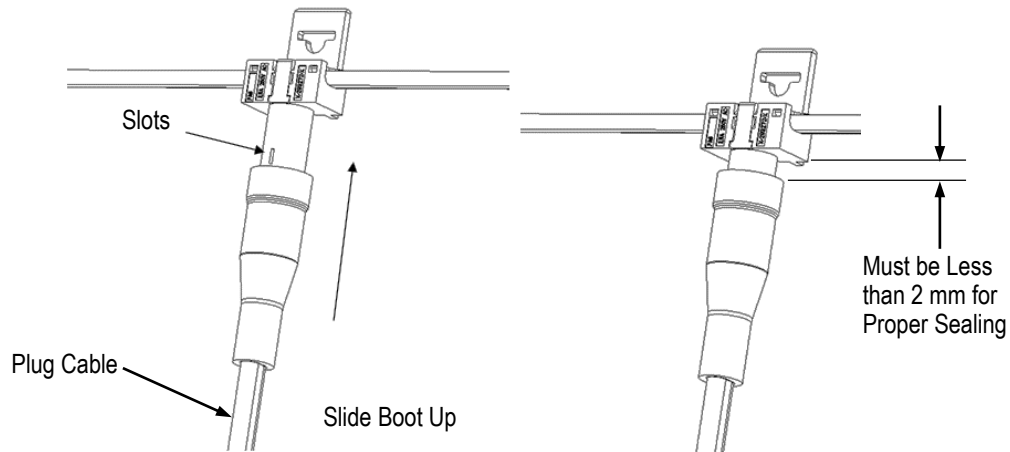

Figure 8

**3.5. Ancillary Items**

**A. Sealing Boot**

If the NECTOR S Bus Bar connector is a sealed version with the sealing gel inside the connector, the NECTOR S connector that plugs into the bottom of the bus bar connector must have a sealing boot to fully seal the assembly. The sealing boot must be the proper type per the options shown in the table in Figure 9. The boot must also be installed on the mating NECTOR S connector cable assembly before it is plugged into the bus bar connector. The boot needs to be pushed up over the slots in the bus bar barrel to be fully seated.



**SEALING BOOT OPTIONS**

SEALING BOOT PART NUMBER	PLUG CABLE TYPE	DIMENSIONS
2213211-1	SVT 2/C 18 AWG	5.59-6.48 mm OD
293284-1	H03VVH2-F, 2 x 0.75 mm <sup>2</sup>	5.6 x 3.4 mm

Figure 9

**B. Wall Outlet (Assembly into Customer Supplied Panel)**

Wall outlet part numbers 293285-1 and 293286-[ ] can be used to mount the bus bar connector into a panel opening. The panel opening must be 75 x 35 +0.5/-0 mm. Panel thickness is to be 0.9 +0.1/-0. See Figure 10.

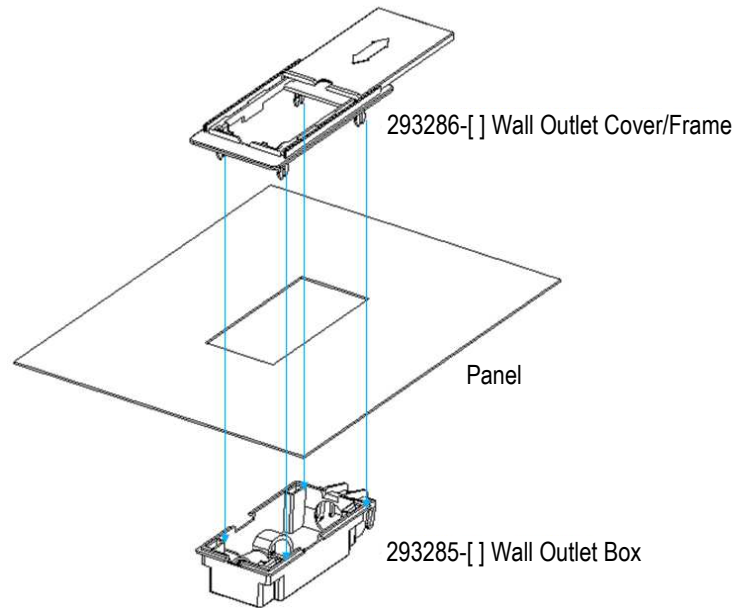

Figure 10

### C. Wall Outlet (Assembly of Bus Bar Connector into Wall Outlet)

The bus bar connector is inserted into the wall outlet assembly by inserting the barrel end first and rotating it into position until it snaps together. The internal boot inside the wall outlet assembly can be used to plug the end of the bus bar connector if not being used right away. See Figure 11.

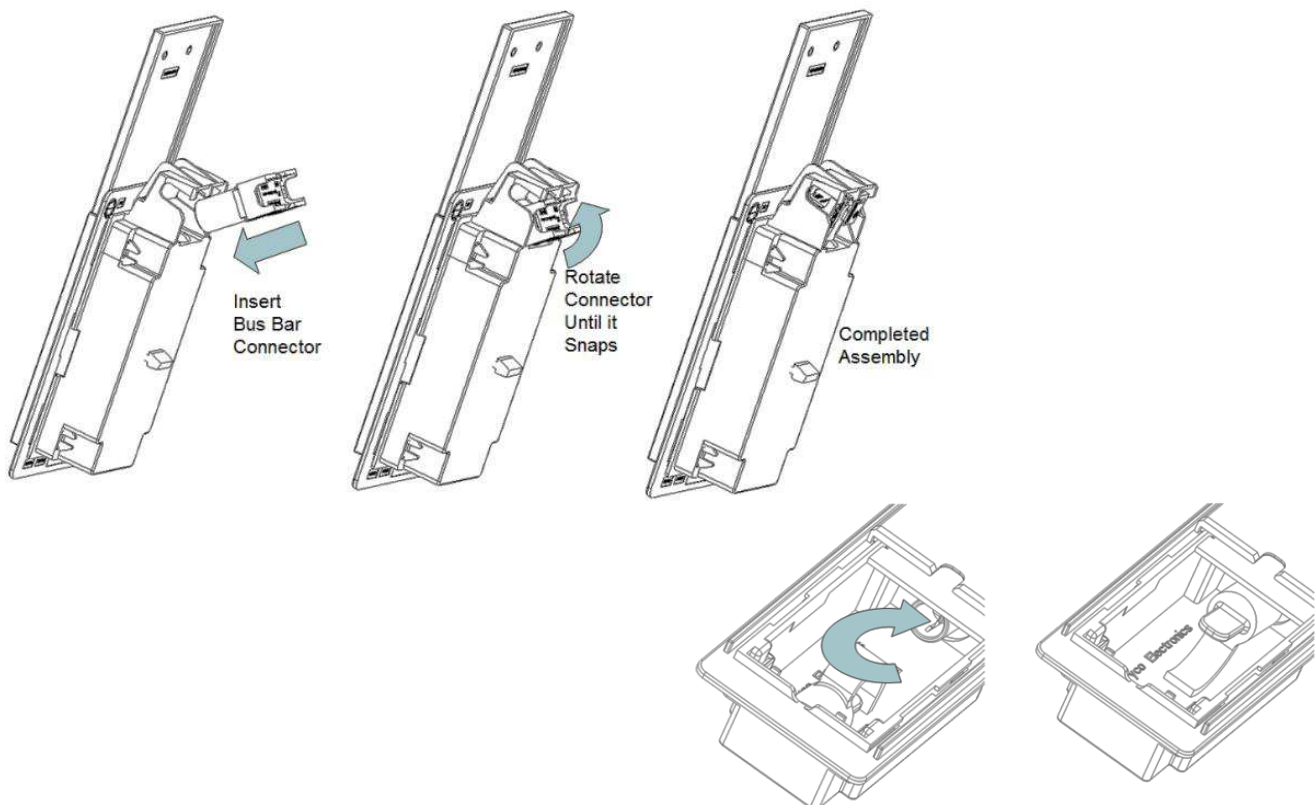

Figure 11

#### 4. QUALIFICATION

No qualifying support was provided at time of publication of this document.

#### 5. TOOLING

Tooling required for assembly and termination of this product are two small flat-bladed screwdrivers and TE Hand Tool (p/n 8-528441-7) with accompanying Instruction Sheet 411-18493.



## 6. VISUAL AID

The illustration below shows a typical application of this product. This illustration should be used by production personnel to ensure a correctly applied product. Applications which do not appear correct should be inspected using the information in the preceding pages of this specification and in the instructional material shipped with the product or tooling.

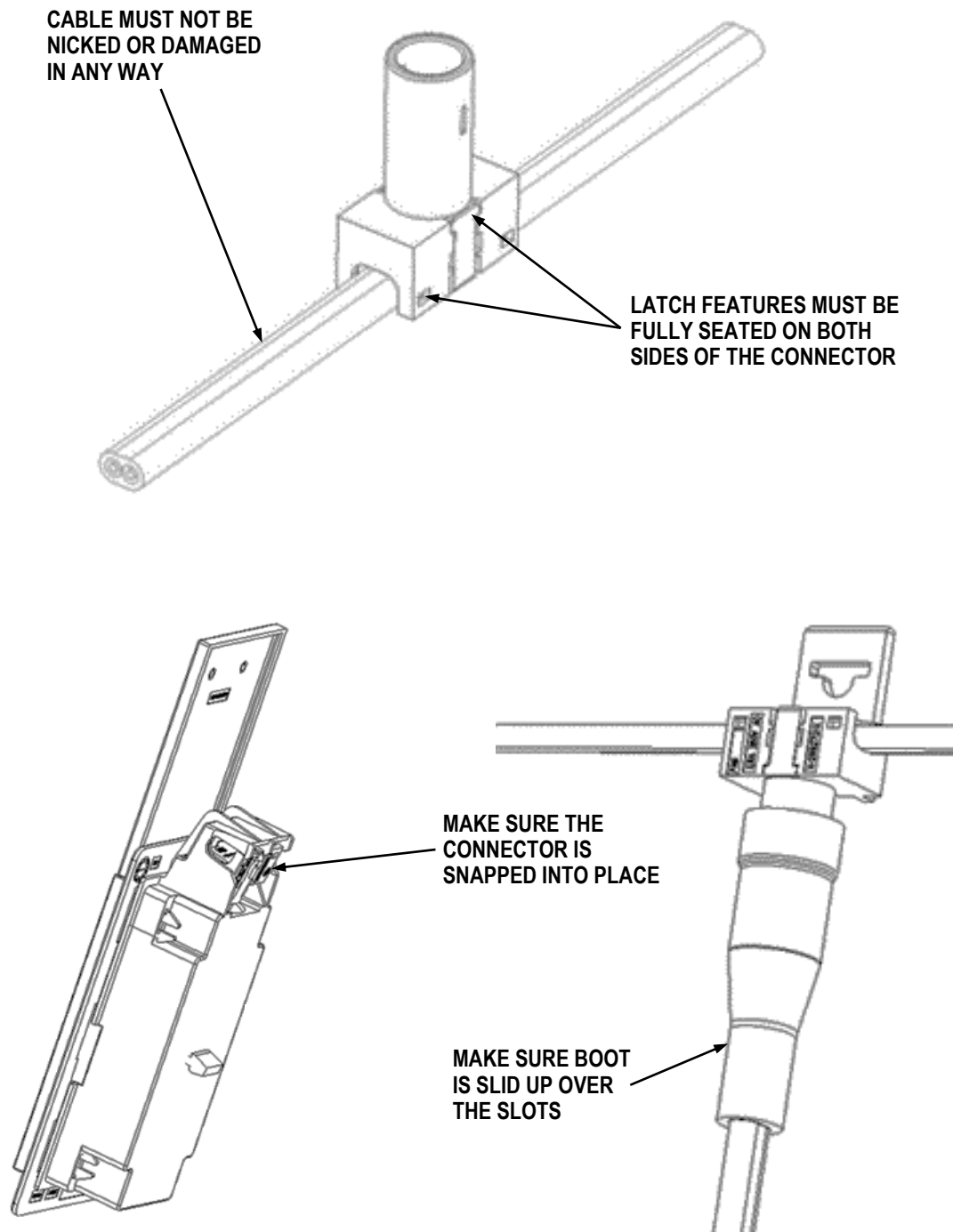

**FIGURE 12. VISUAL AID**

Компания «Океан Электроники» предлагает заключение долгосрочных отношений при поставках импортных электронных компонентов на взаимовыгодных условиях!

Наши преимущества:

- Поставка оригинальных импортных электронных компонентов напрямую с производств Америки, Европы и Азии, а так же с крупнейших складов мира;
- Широкая линейка поставок активных и пассивных импортных электронных компонентов (более 30 млн. наименований);
- Поставка сложных, дефицитных, либо снятых с производства позиций;
- Оперативные сроки поставки под заказ (от 5 рабочих дней);
- Экспресс доставка в любую точку России;
- Помощь Конструкторского Отдела и консультации квалифицированных инженеров;
- Техническая поддержка проекта, помощь в подборе аналогов, поставка прототипов;
- Поставка электронных компонентов под контролем ВП;
- Система менеджмента качества сертифицирована по Международному стандарту ISO 9001;
- При необходимости вся продукция военного и аэрокосмического назначения проходит испытания и сертификацию в лаборатории (по согласованию с заказчиком);
- Поставка специализированных компонентов военного и аэрокосмического уровня качества (Xilinx, Altera, Analog Devices, Intersil, Interpoint, Microsemi, Actel, Aeroflex, Peregrine, VPT, Syfer, Eurofarad, Texas Instruments, MS Kennedy, Miteq, Cobham, E2V, MA-COM, Hittite, Mini-Circuits, General Dynamics и др.);

Компания «Океан Электроники» является официальным дистрибьютором и эксклюзивным представителем в России одного из крупнейших производителей разъемов военного и аэрокосмического назначения «JONHON», а так же официальным дистрибьютором и эксклюзивным представителем в России производителя высокотехнологичных и надежных решений для передачи СВЧ сигналов «FORSTAR».



## JONHON

«JONHON» (основан в 1970 г.)

Разъемы специального, военного и аэрокосмического назначения:

(Применяются в военной, авиационной, аэрокосмической, морской, железнодорожной, горно- и нефтедобывающей отраслях промышленности)

«FORSTAR» (основан в 1998 г.)

ВЧ соединители, коаксиальные кабели,  
кабельные сборки и микроволновые компоненты:

(Применяются в телекоммуникациях гражданского и специального назначения, в средствах связи, РЛС, а так же военной, авиационной и аэрокосмической отраслях промышленности).



Телефон: 8 (812) 309-75-97 (многоканальный)

Факс: 8 (812) 320-03-32

Электронная почта: [ocean@oceanchips.ru](mailto:ocean@oceanchips.ru)

Web: <http://oceanchips.ru/>

Адрес: 198099, г. Санкт-Петербург, ул. Калинина, д. 2, корп. 4, лит. А