

### Devices Connected/Referenced

ADuM3190	2.5 kV rms Isolated Error Amplifier
ADP1621	Constant-Frequency, Current-Mode Step-Up DC-to-DC Controller

## Flyback Power Supply Using a High Stability Isolated Error Amplifier

### EVALUATION AND DESIGN SUPPORT

#### Circuit Evaluation Board

[CN-0342 Circuit Evaluation Board \(EVAL-CN0342-EB1Z\)](#)

#### Design and Integration Files

[Schematics, Layout Files, Bill of Materials](#)

### CIRCUIT FUNCTION AND BENEFITS

The circuit shown in Figure 1 is an isolated, flyback power supply that uses a linear isolated error amplifier to supply the feedback signal from the secondary side to the primary side. Unlike optocoupler-based solutions, which have a nonlinear transfer function that changes over time and temperature, the linear transfer function of the isolated amplifier is stable and minimizes offset and gain errors when transferring the feedback signal across the isolation barrier.

The entire circuit operates from 5 V to 24 V, allowing it to be used with standard industrial and automotive power supplies. The output capability of the circuit is up to 1 A with a 5 V input and 5 V output configuration.

This solution can be adapted for use in applications where higher dc input voltages are used to create lower voltage isolated supplies with good efficiency and a small form factor. Examples include 10 W to 20 W telecommunication and server power supplies, where power efficiency and printed circuit board (PCB) density are important, and -48 V supplies are common.

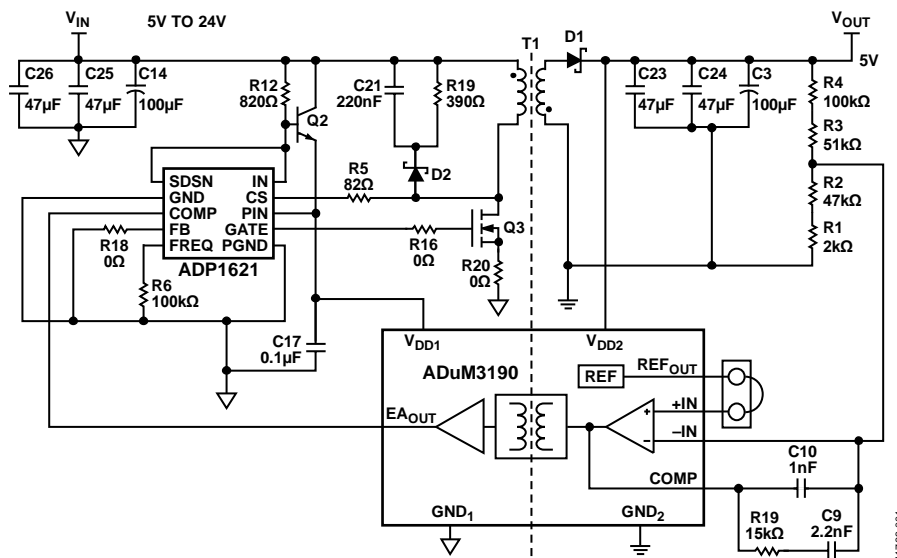

Figure 1. Simplified Schematic of Flyback Power Supply Circuit

#### Rev. 0

Circuits from the Lab reference designs from Analog Devices have been designed and built by Analog Devices engineers. Standard engineering practices have been employed in the design and construction of each circuit, and their function and performance have been tested and verified in a lab environment at room temperature. However, you are solely responsible for testing the circuit and determining its suitability and applicability for your use and application. Accordingly, in no event shall Analog Devices be liable for direct, indirect, special, incidental, consequential or punitive damages due to any cause whatsoever connected to the use of any Circuits from the Lab circuits. (Continued on last page)

## CIRCUIT DESCRIPTION

The isolation amplifier is the [ADuM3190](#), which includes a 1.225 V voltage reference and an error amplifier with 10 MHz unity-gain bandwidth product. An external resistive divider (R1, R2, R3, and R4) and compensation network (R9, C9, and C10) complete the analog feedback loop.

The input supply range of the [ADuM3190](#) is 3.0 V to 20 V on both sides, and internal low dropout regulators provide stable supplies for the voltage reference, error amplifier, and analog isolator. The [ADuM3190](#) is compatible with the Distributed-power Open Standards Alliance (DOSA) output voltage trim method.

The [ADP1621](#) provides pulse-width modulation (PWM) control for the flyback power supply. The internal 5.5 V shunt regulator provides the capability of high supply input voltage with the addition of an external NPN transistor (Q2). The [ADP1621](#) also provides lossless current sensing for current mode operation, providing excellent line and load transient response.

### Setting the Output Voltage

The output voltage is set through a voltage divider from  $V_{OUT}$  to the  $-IN$  pin of [ADuM3190](#). The feedback resistor ratio sets the output voltage of the system. Using the internal voltage reference in the [ADuM3190](#), the regulation voltage at the  $-IN$  pin is 1.225 V.

$$V_{OUT} = 1.225 \text{ V} \times \left( 1 + \frac{R4 + R3}{R1 + R2} \right)$$

For a 5 V output configuration, the resistor divider values are  $R1 = 2 \text{ k}\Omega$ ,  $R2 = 47 \text{ k}\Omega$ ,  $R3 = 51 \text{ k}\Omega$ , and  $R4 = 100 \text{ k}\Omega$ .

### Voltage Reference

The [ADuM3190](#) provides an internal 1.225 V voltage reference specified for  $\pm 1\%$  accuracy over the  $-40^\circ\text{C}$  to  $+125^\circ\text{C}$  temperature range. The reference voltage output pin ( $REF_{OUT}$ ) can be connected to the  $+IN$  pin of the error amplifier to set the output voltage. When higher accuracy or a special output voltage is required, and a different reference voltage must be used, the  $+IN$  pin can also be connected to an external reference.

### Transformer Selection

The transformer choice is important because it dictates the primary inductor current ripple.

For this design example, the following parameters were used:

- $V_{IN} = 5 \text{ V}$
- $V_{OUT} = 5 \text{ V}$
- $I_{OUTMAX} = 1 \text{ A}$
- $f_{SW} = 200 \text{ kHz}$
- Transformer turn ratio = 1:1

The average transformer primary side current,  $I_{LAVG}$ , is given by

$$I_{LAVG} = \frac{I_{LOAD}}{1 - D} \times \frac{N_S}{N_P}$$

where:

$I_{LOAD}$  is the load current.

$D$  is the duty cycle under maximum load current.

$N_S/N_P$  is the turn ratio of the transformer.

The output voltage is

$$V_{OUT} \times (1 - D) \times \frac{N_P}{N_S} = V_{IN} \times D$$

The duty cycle ( $D$ ) is 50% because the output and input are both 5 V, and the transformer turn ratio is 1:1.

The peak-to-peak primary inductor ripple current is inversely proportional to the inductor value.

$$\Delta I_L = \frac{V_{IN} \times D}{f_{SW} \times L}$$

where:

$f_{SW}$  is the switching frequency.

$L$  is the primary inductor value.

Assuming continuous conduction mode (CCM) operation, the primary inductor current is given by

$$I_{LPK} = \frac{I_{LOAD}}{1 - D} \times \frac{N_S}{N_P} + \frac{V_{IN} \times D}{2 \times f_{SW} \times L}$$

Assuming the primary ripple current is 50% of the average current on the transformer primary side, a reasonable choice for the inductor value is

$$L = \frac{V_{IN} \times D \times (1 - D)}{0.5 \times f_{SW} \times I_{LOAD}} \times \frac{N_P}{N_S} = \frac{5 \text{ V} \times 0.5 (1 - 0.5)}{0.5 \times 200 \text{ kHz} \times 1 \text{ A}} = 12.5 \mu\text{H}$$

The transformer used in this design is a 1:1 turn ratio transformer with 16  $\mu\text{H}$  primary side inductance (Halo Electronics, Inc., TGB01-P099EP13LF).

### Compensation Network

In a flyback topology power supply, the output load resistance, the output capacitor, and its effective series resistance (ESR) add a zero and a pole at frequencies that are dependent on the component type and values. There is also a right half plane (RHP) zero in the control-to-output transfer function. Because the RHP zero reduces the phase by  $90^\circ$ , the frequency of 0 dB gain (crossover frequency) is lower than the RHP zero.

With the [ADuM3190](#) providing the error amplifier, a Type II compensation network can be provided from the  $-IN$  pin to the COMP pin to compensate for the control loop for stability. The compensation network values depend on the selected components.

The zeros and poles of a Type II compensation network are derived as follows:

$$f_{ZERO} = \frac{1}{2\pi \times R9 \times C9}$$

$$f_{POLE} = \frac{C10 + C9}{2\pi \times R9 \times C10 \times C9}$$

In this particular design, the compensation network is set by  $R9 = 15 \text{ k}\Omega$ ,  $C9 = 2.2 \text{ nF}$ , and  $C10 = 1 \text{ nF}$ .

The zero and the pole provided by this compensation network are  $f_{ZERO} = 4.8 \text{ kHz}$  and  $f_{POLE} = 15.4 \text{ kHz}$ . Increasing the zero and pole frequency improves the load transient response but decreases the phase margin of the feedback loop and can cause instability in the power supply.

### Snubber Network

When the power MOSFET (Q3) is turned off, there is a high voltage spike on the drain due to the transformer leakage inductance. This excessive voltage can overstress the power MOSFET and lead to a reliability issue or damage. Therefore, it is necessary to use an additional network to clamp the voltage.

The resistor, capacitor, and diode (R19, C21, and D2) snubber network absorbs the current in the leakage inductance by turning on the snubber diode when the MOSFET drain voltage exceeds the cathode voltage of D2.

The ADP1621 operates in lossless mode with the drain of the power MOSFET connected to the CS pin. In a practical design, limit the voltage at the CS pin to an absolute maximum of 33 V, and a practical maximum of 30 V to maintain accuracy. If the measured peak voltage exceeds 30 V, or if a more accurate current limit is desired, connect the CS pin to an external current sense resistor in the source of the MOSFET.

### Primary Side Power Supply

The ADP1621 supply voltage range is 2.9 V to 5.5 V, and the ADuM3190 supply voltage range is 3.0 V to 20 V. To work with a 5 V to 12 V input voltage supply, a small-signal NPN transistor (Q2) can be used as a voltage regulator.

The IN pin of ADP1621 has a 5.5 V internal voltage regulator and is connected to the base node of the NPN transistor Q2. This connection biases Q2 so that the emitter node can be regulated to  $5.5 \text{ V} - 0.7 \text{ V} = 4.8 \text{ V}$ , which can be used as the power supply voltage for the ADP1621 (PIN) and the ADuM3190 ( $V_{DD1}$ ).

### Secondary Side Power Supply

The ADuM3190 has a 3.0 V to 20 V supply voltage range on the secondary side ( $V_{DD2}$ ), with an internal regulator providing a 3.0 V operating voltage. If  $V_{OUT}$  is set higher than 20 V, add an external voltage regulator to provide the specified  $V_{DD2}$  voltage.

### Insulation and Safety

The ADuM3190 is packaged in a small, 16-lead QSOP package for a 2.5 kV rms isolation voltage rating.

Safety specifications for the ADuM3190 are shown in Table 1.

**Table 1. Safety Specifications for the ADuM3190**

Parameter	Value	Unit
Rated Dielectric Insulation Voltage	2500	V rms
Minimum External Air Gap (Clearance)	3.8 min	mm
Minimum External Tracking (Creepage)	3.1 min	mm
Minimum Internal Gap (Internal Clearance)	0.017 min	mm
Tracking Resistance (Comparative Tracking Index)	>400	V
Isolation Material Group	II	

### COMMON VARIATIONS

For higher input voltages, the current sense resistor must be used with a current control loop. Change the R20 resistor from 0  $\Omega$  to the value required by the application. For the 1 A output configuration, choose a sense resistor value of 50 m $\Omega$ . According to the internal current feedback loop in the ADP1621, the maximum PWM duty cycle of switching is reduced when the current sensing voltage rises. If the sense resistor value is too high, the duty cycle of the switching is limited; the maximum output current is then also limited under the specific output voltage. The ADP1621 compensation pin (COMP) has a 0 V to 2 V effective input voltage range. It is recommended to limit the voltage on the CS pin to less than 0.1 V to guarantee an adequate switching duty cycle.

When working with an input voltage less than 5 V, bypass the input regulation transistor by shorting the jumper between the collector and the emitter.

For applications such as telecommunication or server power supplies with a -48 V input, regulate the supply voltage for the primary side controller to +5 V. The NPN transistor Q2 needs a higher  $V_{CE}$  breakdown voltage, and the power MOSFET Q3 needs a higher  $V_{DS}$  (100 V,  $V_{DSMAX}$ ). In addition, change the diode in the RCD snubber circuit, D2, to a 70 V reverse voltage rating.

To reduce the current on the internal regulator in the ADP1621, increase R12 to 1.5 k $\Omega$ .

Table 2 summarizes the alternative components selected for different input voltage configurations.

**Table 2. Component Values for Different Configurations**

Input Voltage	5 V to 7 V	7 V to 24 V	24 V to 48 V
Q2	PMST2369	PMST2369	BC846
Q3	NTD18N06L	NTD18N06L	NVD6824NL
D2	MBR0540T1	MBR0540T1	MMSD701T1
R12	390 $\Omega$	820 $\Omega$	1.5 k $\Omega$

A complete design support package, including the schematics, layouts, and bill of materials, is available at [www.analog.com/CN0342-DesignSupport](http://www.analog.com/CN0342-DesignSupport).

**Performance Results**

Figure 2 shows the measured efficiency with three different input voltages: 5 V, 12 V, and 24 V.

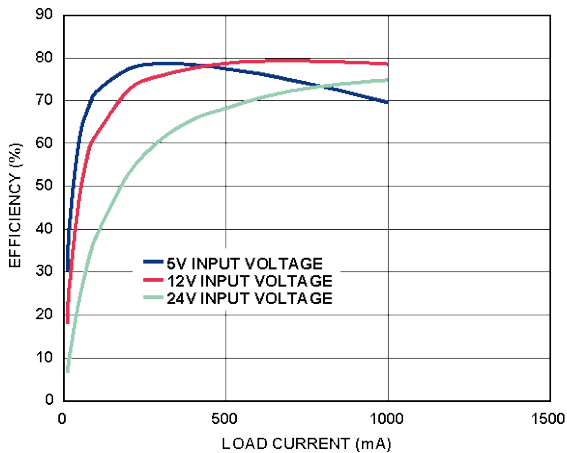

Figure 2. Flyback Circuit Output Efficiency vs. Load Current for Input Voltages of 5 V, 12 V, and 24 V

Figure 3 shows the output voltage over a temperature range from  $-40^{\circ}\text{C}$  to  $+125^{\circ}\text{C}$ . The total output voltage error over this range is less than  $\pm 20\text{ mV}$  ( $\pm 0.4\%$ ).

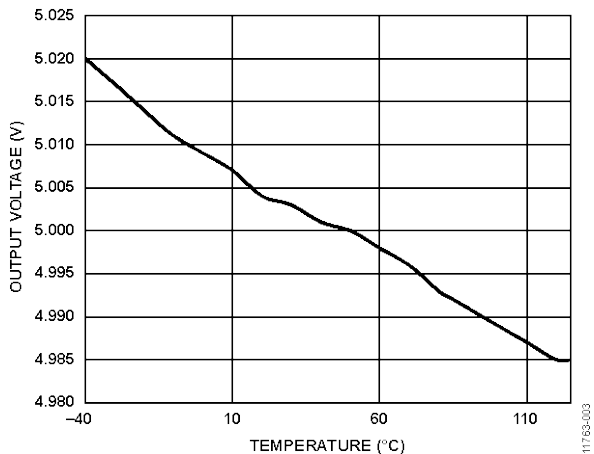

Figure 3. Flyback Circuit Output Voltage vs. Temperature

Figure 4 and Figure 5 show the transient response for increasing and decreasing load current. The transient response time is  $32\ \mu\text{s}$  for a load current increase from 100 mA to 900 mA, and  $45\ \mu\text{s}$  for a load current decrease from 900 mA to 100 mA.

A photograph of the [EVAL-CN0342-EB1Z](#) evaluation board is shown in Figure 6.

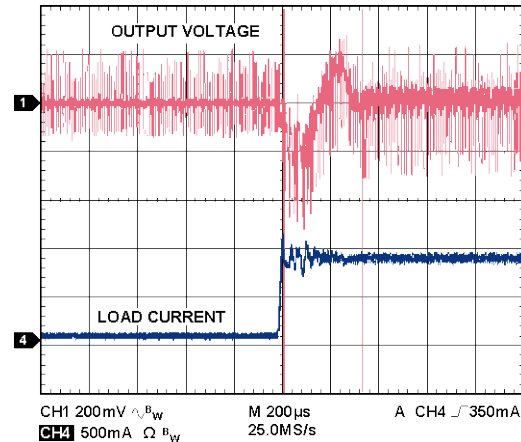

Figure 4. 100 mA to 900 mA Load Transient Response

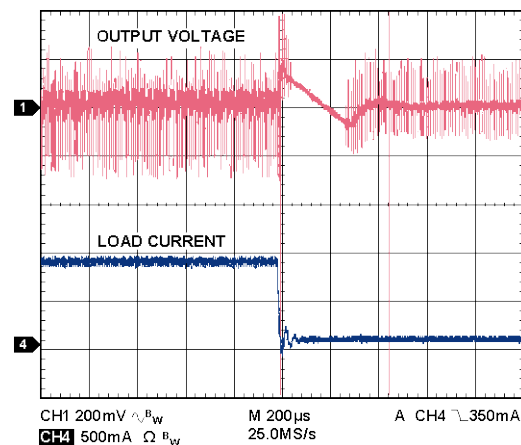

Figure 5. 900 mA to 100 mA Load Transient Response

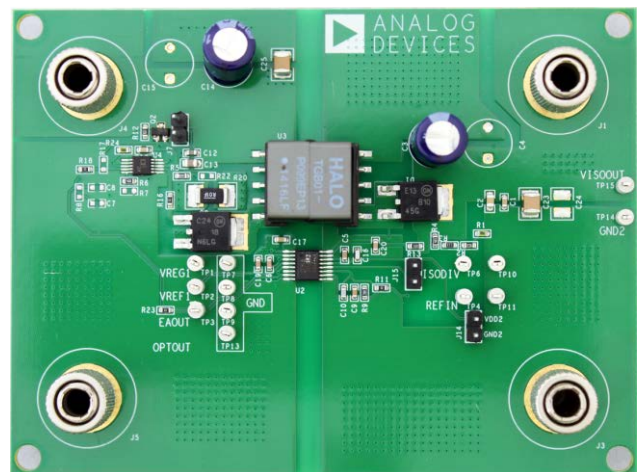

Figure 6. EVAL-CN0342-EB1Z Evaluation Board Photo

## CIRCUIT EVALUATION AND TEST

The circuit is tested using a dc power supply and a source/measurement unit for efficiency and load regulation. Load transient response and output ripple are measured with an oscilloscope and current probe.

### Equipment Needed

The following equipment is required:

- A 30 V power supply with 3 A current output capability and current measurement function
- A source/measurement unit with 1 A load current capability
- An oscilloscope with >300 MHz bandwidth and a current probe with >1 A input range

### Getting Started

The circuit does not require software support for evaluation. Connect the power supply, and the output is regulated based on the configuration.

### Setup and Test

Connect the 5 V power supply to the primary side input connector (J4), and connect ground to J5.

Connect the source meter to the secondary side, where J1 is the 5 V output, and J3 is the output ground.

Place a jumper on J15 to use the internal 1.225 V voltage reference of the [ADuM3190](#).

## LEARN MORE

[CN0342 Design Support Package](#).

Gottlieb, Irving M. *Power Supplies, Switching Regulators, Inverters, and Converters*. Second Edition, McGraw Hill (TAB Books), 1994.

Brown, Marty. *Practical Switching Power Supply Design*. Academic Press, 1990.

Brown, Marty. *Power Supply Cookbook*. Butterworth-Heinemann, 1994.

Lenk, John D. *Simplified Design of Switching Power Supplies*. Butterworth-Heinemann, 1995.

Billings, Keith. *Switchmode Power Supply Handbook*. McGraw-Hill, 1989.

Chryssis, George. *High-Frequency Switching Power Supplies: Theory and Design*. Second Edition, McGraw-Hill, 1989.

Pressman, Abraham I. *Switching Power Supply Design*. McGraw-Hill, 1991.

[ADIsimPower Power Management Design Tool](#).  
[Analog Devices, Inc.](#)

## Data Sheets and Evaluation Boards

[ADuM3190 Data Sheet](#)

[ADP1621 Data Sheet](#)

## REVISION HISTORY

11/14—Revision 0: Initial Version

(Continued from first page) Circuits from the Lab reference designs are intended only for use with Analog Devices products and are the intellectual property of Analog Devices or its licensors. While you may use the Circuits from the Lab reference designs in the design of your product, no other license is granted by implication or otherwise under any patents or other intellectual property by application or use of the Circuits from the Lab reference designs. Information furnished by Analog Devices is believed to be accurate and reliable. However, Circuits from the Lab reference designs are supplied "as is" and without warranties of any kind, express, implied, or statutory including, but not limited to, any implied warranty of merchantability, noninfringement or fitness for a particular purpose and no responsibility is assumed by Analog Devices for their use, nor for any infringements of patents or other rights of third parties that may result from their use. Analog Devices reserves the right to change any Circuits from the Lab reference designs at any time without notice but is under no obligation to do so.

Компания «Океан Электроники» предлагает заключение долгосрочных отношений при поставках импортных электронных компонентов на взаимовыгодных условиях!

Наши преимущества:

- Поставка оригинальных импортных электронных компонентов напрямую с производств Америки, Европы и Азии, а так же с крупнейших складов мира;
- Широкая линейка поставок активных и пассивных импортных электронных компонентов (более 30 млн. наименований);
- Поставка сложных, дефицитных, либо снятых с производства позиций;
- Оперативные сроки поставки под заказ (от 5 рабочих дней);
- Экспресс доставка в любую точку России;
- Помощь Конструкторского Отдела и консультации квалифицированных инженеров;
- Техническая поддержка проекта, помощь в подборе аналогов, поставка прототипов;
- Поставка электронных компонентов под контролем ВП;
- Система менеджмента качества сертифицирована по Международному стандарту ISO 9001;
- При необходимости вся продукция военного и аэрокосмического назначения проходит испытания и сертификацию в лаборатории (по согласованию с заказчиком);
- Поставка специализированных компонентов военного и аэрокосмического уровня качества (Xilinx, Altera, Analog Devices, Intersil, Interpoint, Microsemi, Actel, Aeroflex, Peregrine, VPT, Syfer, Eurofarad, Texas Instruments, MS Kennedy, Miteq, Cobham, E2V, MA-COM, Hittite, Mini-Circuits, General Dynamics и др.);

Компания «Океан Электроники» является официальным дистрибьютором и эксклюзивным представителем в России одного из крупнейших производителей разъемов военного и аэрокосмического назначения «JONHON», а так же официальным дистрибьютором и эксклюзивным представителем в России производителя высокотехнологичных и надежных решений для передачи СВЧ сигналов «FORSTAR».



## JONHON

«JONHON» (основан в 1970 г.)

Разъемы специального, военного и аэрокосмического назначения:

(Применяются в военной, авиационной, аэрокосмической, морской, железнодорожной, горно- и нефтедобывающей отраслях промышленности)

«FORSTAR» (основан в 1998 г.)

ВЧ соединители, коаксиальные кабели, кабельные сборки и микроволновые компоненты:

(Применяются в телекоммуникациях гражданского и специального назначения, в средствах связи, РЛС, а так же военной, авиационной и аэрокосмической отраслях промышленности).



Телефон: 8 (812) 309-75-97 (многоканальный)

Факс: 8 (812) 320-03-32

Электронная почта: [ocean@oceanchips.ru](mailto:ocean@oceanchips.ru)

Web: <http://oceanchips.ru/>

Адрес: 198099, г. Санкт-Петербург, ул. Калинина, д. 2, корп. 4, лит. А