

Narrow beam LED in MIDLED package (940 nm)

Version 1.7

SFH 4640



Features:

- High Power Infrared LED (55 mW)
- Short switching times
- Narrow halfangle ($\pm 15^\circ$)
- The product qualification test plan is based on the guidelines of AEC-Q101-REV-C, Stress Test Qualification for Automotive Grade Discrete Semiconductors.
- Taping as Toplooker
- Also available as Sidelooker (SFH4645)

Applications

- Infrared Illumination for cameras
- Data transmission
- Automotive technology
- Remote control

Notes

Depending on the mode of operation, these devices emit highly concentrated non visible infrared light which can be hazardous to the human eye. Products which incorporate these devices have to follow the safety precautions given in IEC 60825-1 and IEC 62471.

Ordering Information

| Type: | Radiant Intensity I_e [mW/sr] $I_F= 100 \text{ mA}, t_p= 20 \text{ ms}$ | Ordering Code |
|-------------|---|---------------|
| SFH 4640 | 80 (≥ 40) | Q65110A9369 |
| SFH 4640-UV | 40 ... 125 | Q65111A3977 |

Note: Measured at a solid angle of $\Omega = 0.01 \text{ sr}$

Maximum Ratings ($T_A = 25\text{ °C}$)

| Parameter | Symbol | Values | Unit |
|--|------------|-------------|-------|
| Operating temperature range | T_{op} | -40 ... 100 | °C |
| Storage temperature range | T_{stg} | -40 ... 100 | °C |
| Reverse voltage | V_R | 5 | V |
| Forward current | I_F | 100 | mA |
| Surge current ($t_p \leq 300\ \mu\text{s}$, $D = 0$) | I_{FSM} | 1 | A |
| Power consumption | P_{tot} | 180 | mW |
| ESD withstand voltage (acc. to ANSI/ ESDA/ JEDEC JS-001 - HBM) | V_{ESD} | 2 | kV |
| Thermal resistance junction - ambient ^{1) page 12} | R_{thJA} | 340 | K / W |
| Thermal resistance junction - soldering point ^{2) page 12} | R_{thJS} | 180 | K / W |

Characteristics ($T_A = 25\text{ °C}$)

| Parameter | Symbol | Values | Unit |
|---|----------------------------|------------------------------------|---------------|
| Peak wavelength ($I_F = 100\text{ mA}$, $t_p = 20\text{ ms}$) | (typ) λ_{peak} | 950 | nm |
| Centroid wavelength ($I_F = 100\text{ mA}$, $t_p = 20\text{ ms}$) | (typ) $\lambda_{centroid}$ | 940 | nm |
| Spectral bandwidth at 50% of I_{max} ($I_F = 100\text{ mA}$, $t_p = 20\text{ ms}$) | (typ) $\Delta\lambda$ | 42 | nm |
| Half angle | (typ) φ | ± 15 | ° |
| Dimensions of active chip area | (typ) L x W | 0.3 x 0.3 | mm x mm |
| Rise and fall time of I_e (10% and 90% of $I_{e\ max}$) ($I_F = 100\text{ mA}$, $R_L = 50\ \Omega$) | (typ) t_r, t_f | 12 | ns |
| Forward voltage ($I_F = 100\text{ mA}$, $t_p = 20\text{ ms}$) | (typ (max)) V_F | 1.5 (≤ 1.8) | V |
| Forward voltage ($I_F = 1\text{ A}$, $t_p = 100\ \mu\text{s}$) | (typ (max)) V_F | 2.3 (≤ 3) | V |
| Reverse current ($V_R = 5\text{ V}$) | I_R | not designed for reverse operation | μA |
| Total radiant flux ($I_F = 100\text{ mA}$, $t_p = 20\text{ ms}$) | (typ) Φ_e | 55 | mW |

| Parameter | | Symbol | Values | Unit |
|--|-------|--------------|--------|--------|
| Temperature coefficient of I_e or Φ_e ($I_F = 100$ mA, $t_p = 20$ ms) | (typ) | TC_I | -0.5 | % / K |
| Temperature coefficient of V_F ($I_F = 100$ mA, $t_p = 20$ ms) | (typ) | TC_V | -1.3 | mV / K |
| Temperature coefficient of wavelength ($I_F = 100$ mA, $t_p = 20$ ms) | (typ) | TC_λ | 0.3 | nm / K |

Grouping ($T_A = 25$ °C)

| Group | Min Radiant Intensity | Max Radiant Intensity | Typ Radiant Intensity |
|-------------|--|--|--|
| | $I_F = 100$ mA, $t_p = 20$ ms $I_{e, \min}$ [mW / sr] | $I_F = 100$ mA, $t_p = 20$ ms $I_{e, \max}$ [mW / sr] | $I_F = 1$ A, $t_p = 25$ μ s $I_{e, \text{typ}}$ [mW / sr] |
| SFH 4640-U | 40 | 80 | 420 |
| SFH 4640-V | 63 | 125 | 660 |
| SFH 4640-AW | 100 | 200 | 1050 |

Note: measured at a solid angle of $\Omega = 0.01$ sr

Only one group in one packing unit (variation lower 2:1).

Relative Spectral Emission ^{3) page 12}

$$I_{\text{rel}} = f(\lambda), T_A = 25^\circ\text{C}$$

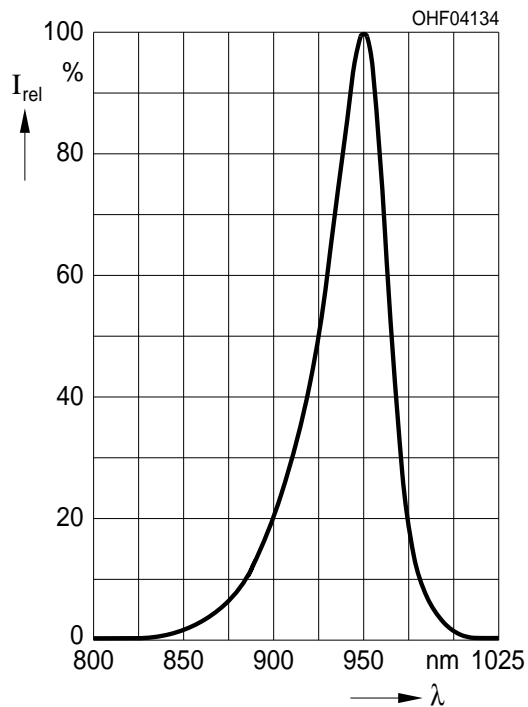

Radiant Intensity ^{3) page 12}

$$I_e / I_e(100 \text{ mA}) = f(I_F), \text{ single pulse, } t_p = 25 \mu\text{s}, T_A = 25^\circ\text{C}$$

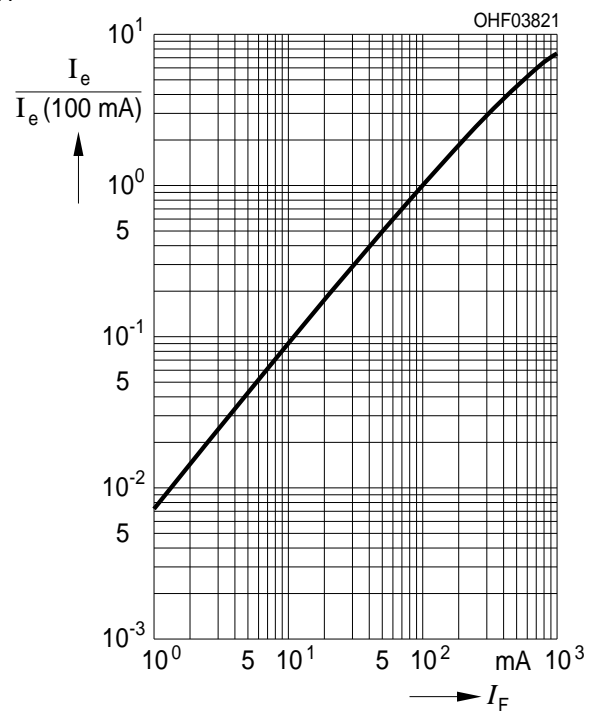

Max. Permissible Forward Current

$I_F = f(T_A), R_{thJA} = 340 \text{ K/W}$

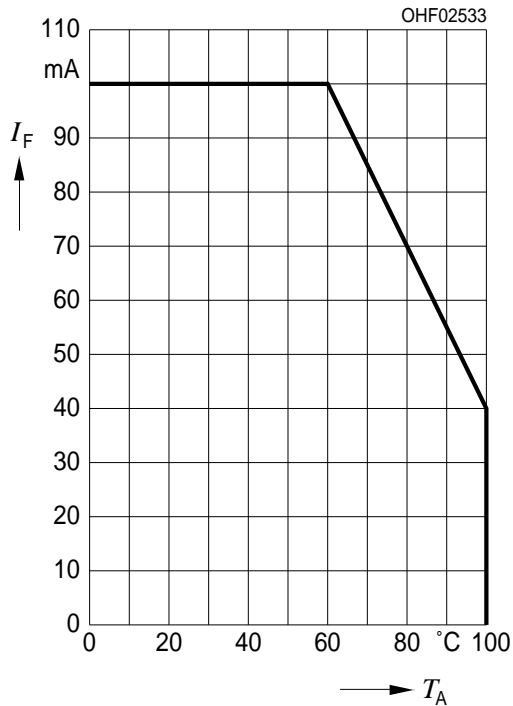

Forward Current ^{3) page 12}

$I_F = f(V_F), \text{ single pulse, } t_p = 100 \mu\text{s}, T_A = 25^\circ\text{C}$

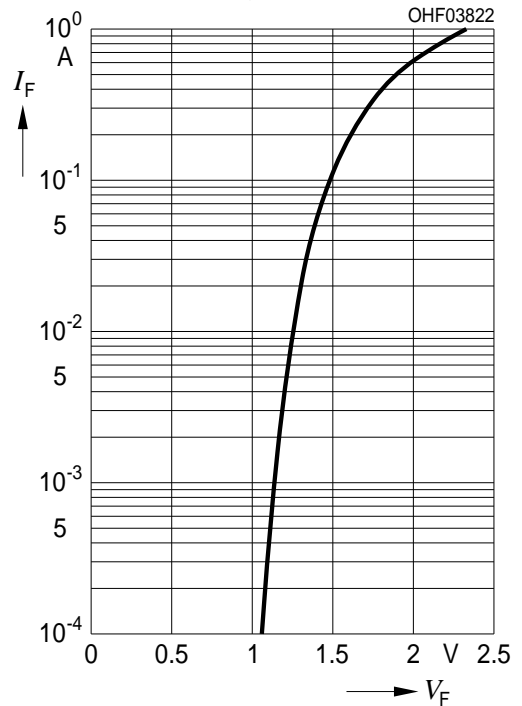

Permissible Pulse Handling Capability

$I_F = f(t_p), T_A = 25^\circ\text{C}, \text{ duty cycle } D = \text{parameter}$

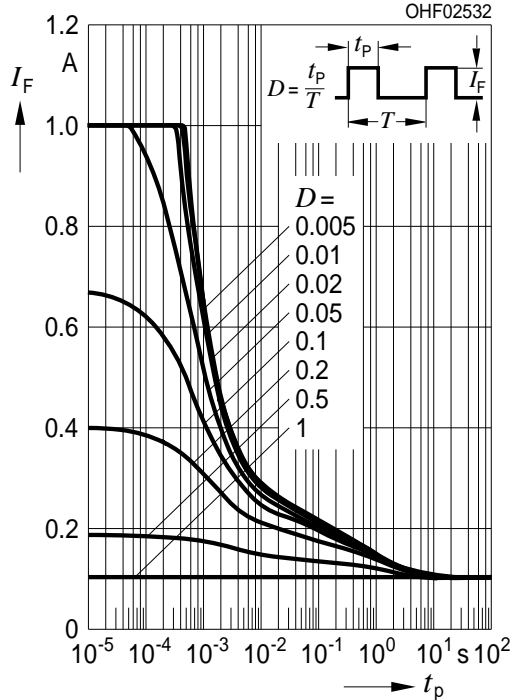

Radiation Characteristics ^{3) page 12}

$I_{rel} = f(\phi), T_A = 25^\circ\text{C}$

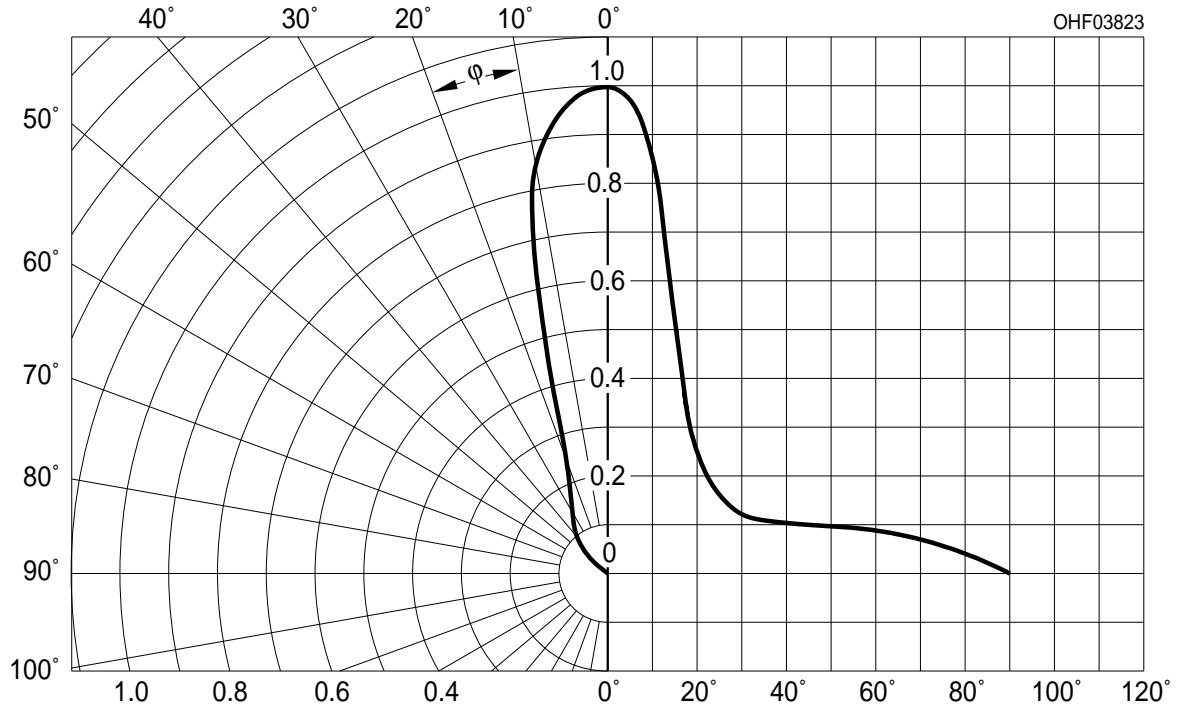

Package Outline

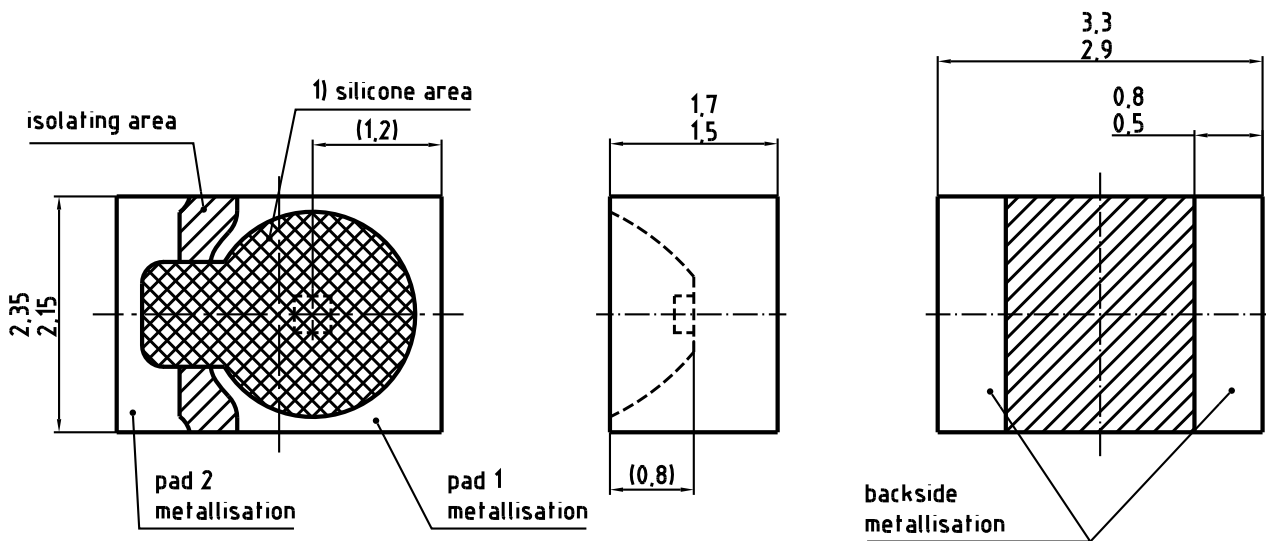

- 1) Device casted with silicone.
Avoid mechanical stress on silicone surface.

Dimensions in mm.

C63062-A3811-A1...-15

| Pad | Description |
|-----|-------------|
| 1 | Anode |
| 2 | Cathode |

Package

MIDLED, Silicone, colourless, clear

Approximate Weight:

23 mg

Recommended Solder Pad

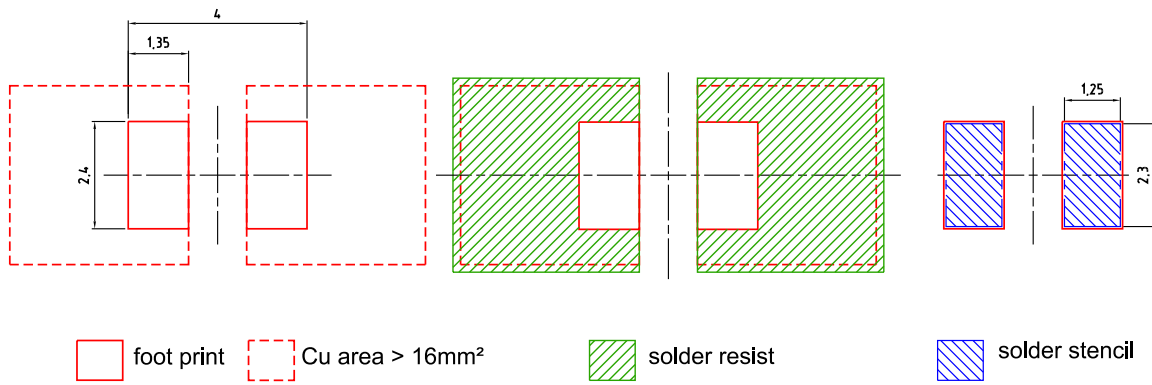

Component Location on Pad

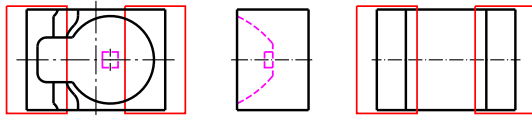

Dimensions in mm.

E062.3010.42-03

Reflow Soldering Profile

Product complies to MSL Level 2 acc. to JEDEC J-STD-020E



OHA04612

| Profile Feature Profil-Charakteristik | Symbol Symbol | Pb-Free (SnAgCu) Assembly | | | Unit Einheit |
|---|------------------|---------------------------|----------------|---------|-----------------|
| | | Minimum | Recommendation | Maximum | |
| Ramp-up rate to preheat*) 25 °C to 150 °C | | | 2 | 3 | K/s |
| Time t_S T_{Smin} to T_{Smax} | t_S | 60 | 100 | 120 | s |
| Ramp-up rate to peak*) T_{Smax} to T_P | | | 2 | 3 | K/s |
| Liquidus temperature | T_L | 217 | | | °C |
| Time above liquidus temperature | t_L | | 80 | 100 | s |
| Peak temperature | T_P | | 245 | 260 | °C |
| Time within 5 °C of the specified peak temperature $T_P - 5$ K | t_P | 10 | 20 | 30 | s |
| Ramp-down rate* T_P to 100 °C | | | 3 | 6 | K/s |
| Time 25 °C to T_P | | | | 480 | s |

All temperatures refer to the center of the package, measured on the top of the component

* slope calculation DT/Dt : Dt max. 5 s; fulfillment for the whole T-range

Taping

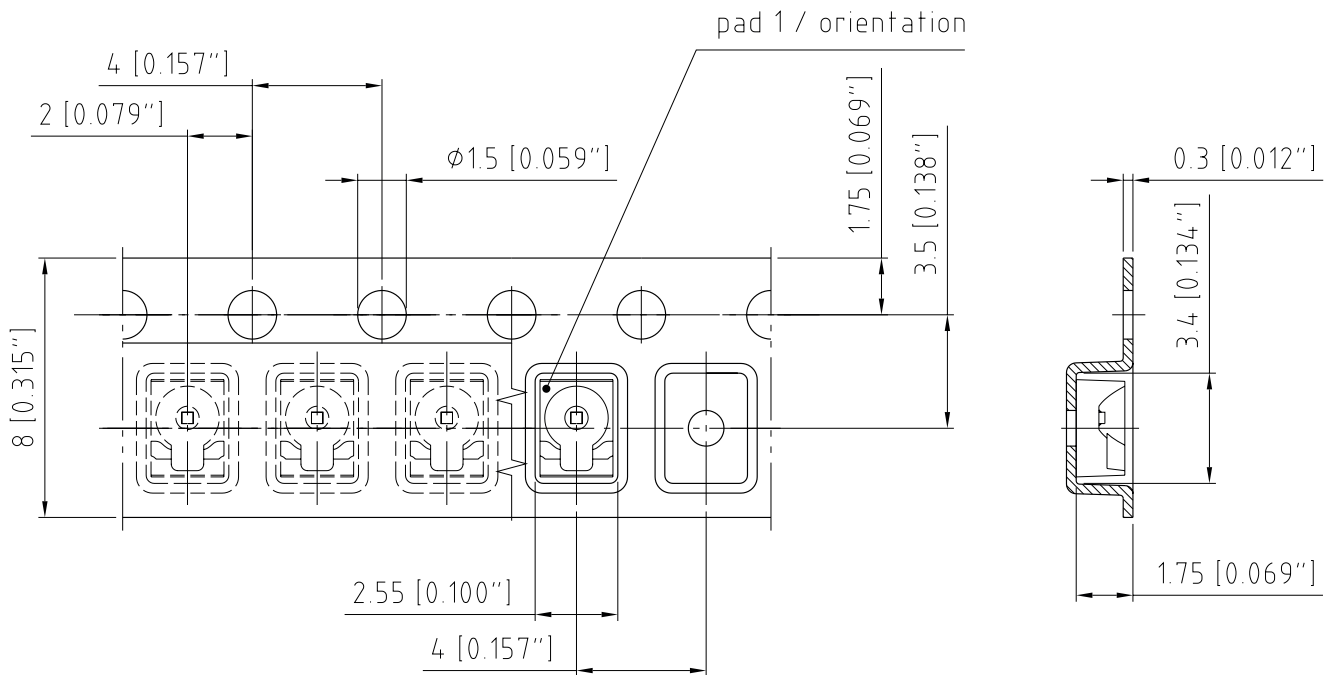

C63062-A3811-B7-03

Dimensions in mm (inch).

Note:

Pad 1 = Anode

Tape and Reel

8 mm tape with 2000 pcs. on $\phi 180$ mm reel

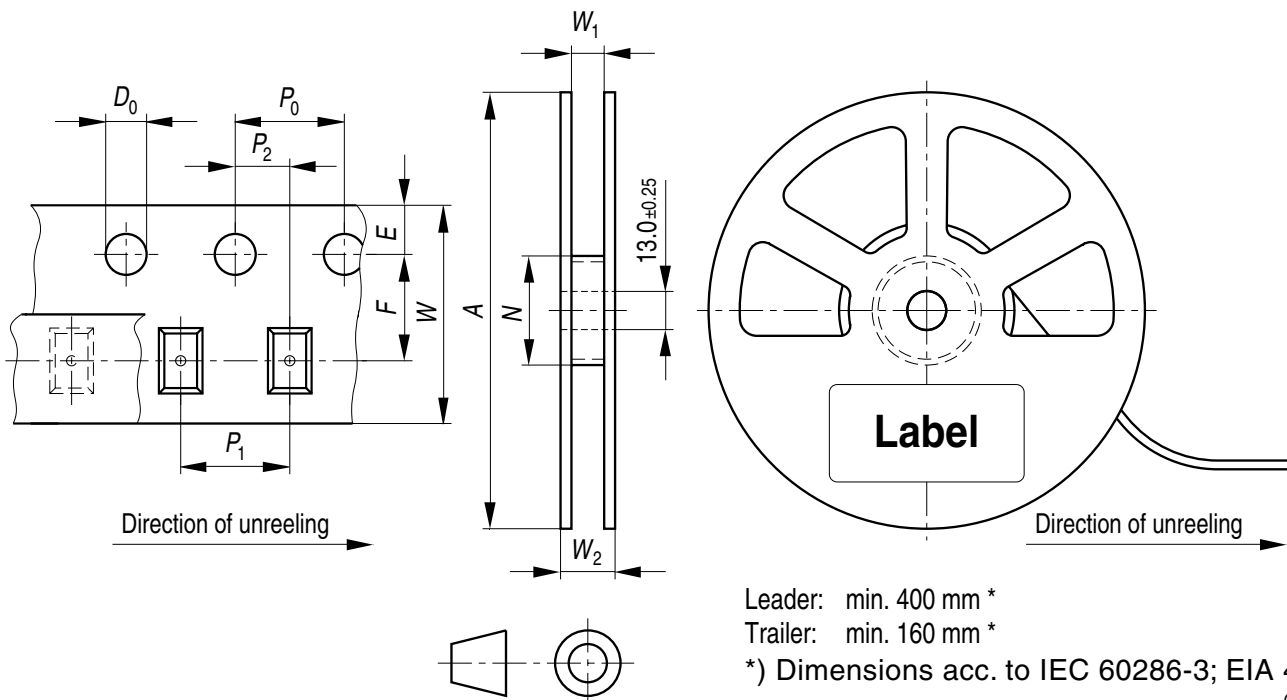

Leader: min. 400 mm *

Trailer: min. 160 mm *

*) Dimensions acc. to IEC 60286-3; EIA 481-D

OHAY0324

Tape dimensions [mm]

| W | P ₀ | P ₁ | P ₂ | D ₀ | E | F |
|----------------|----------------|---------------------------|----------------|----------------|------------|------------|
| 8 + 0.3 / -0.1 | 4 ± 0.1 | 2 ± 0.05 or 4 ± 0.1 | 2 ± 0.05 | 1.5 ± 0.1 | 1.75 ± 0.1 | 3.5 ± 0.05 |

Reel dimensions [mm]

| A | W | N _{min} | W ₁ | W _{2max} |
|-----|---|------------------|----------------|-------------------|
| 180 | 8 | 60 | 8.4 + 2 | 14.4 |

Barcode-Product-Label (BPL)

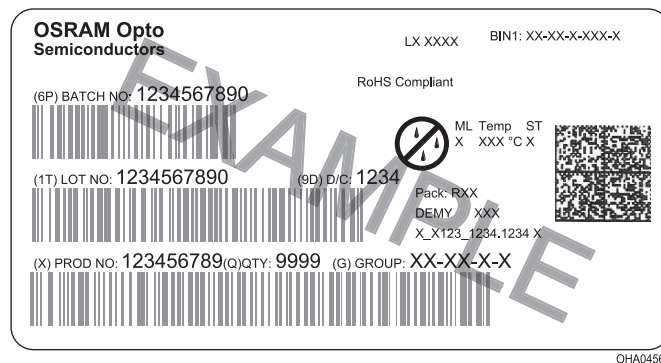

Dry Packing Process and Materials

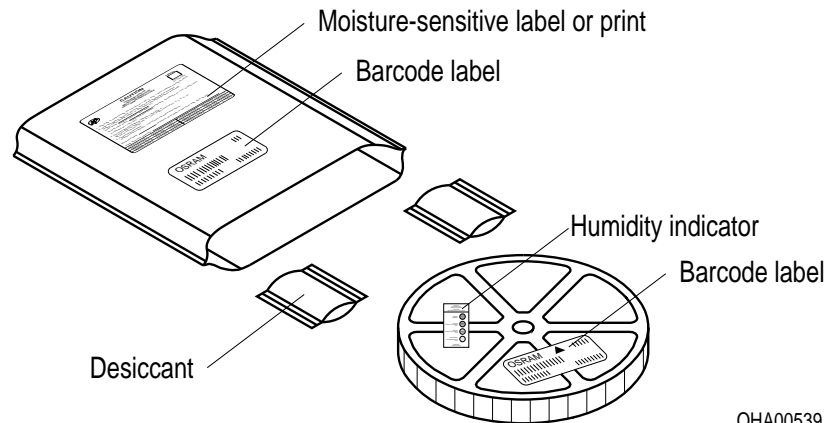

Note:

Moisture-sensitive product is packed in a dry bag containing desiccant and a humidity card. Regarding dry pack you will find further information in the internet. Here you will also find the normative references like JEDEC.

Transportation Packing and Materials

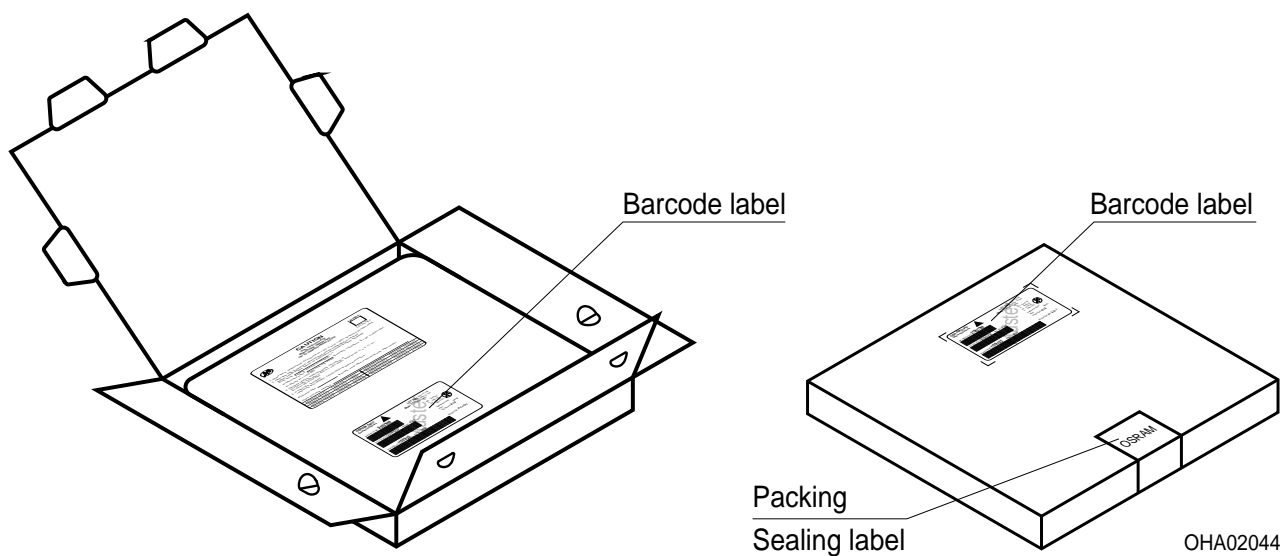

Dimensions of transportation box in mm

| Width | Length | Height |
|---------|---------|--------|
| 200 ± 5 | 195 ± 5 | 30 ± 5 |

Disclaimer

Language english will prevail in case of any discrepancies or deviations between the two language wordings.

Attention please!

The information describes the type of component and shall not be considered as assured characteristics.

Terms of delivery and rights to change design reserved. Due to technical requirements components may contain dangerous substances.

For information on the types in question please contact our Sales Organization.

If printed or downloaded, please find the latest version in the Internet.

Packing

Please use the recycling operators known to you. We can also help you – get in touch with your nearest sales office.

By agreement we will take packing material back, if it is sorted. You must bear the costs of transport. For packing material that is returned to us unsorted or which we are not obliged to accept, we shall have to invoice you for any costs incurred.

Components used in life-support devices or systems must be expressly authorized for such purpose!

Critical components* may only be used in life-support devices** or systems with the express written approval of OSRAM OS.

*) A critical component is a component used in a life-support device or system whose failure can reasonably be expected to cause the failure of that life-support device or system, or to affect its safety or the effectiveness of that device or system.

**) Life support devices or systems are intended (a) to be implanted in the human body, or (b) to support and/or maintain and sustain human life. If they fail, it is reasonable to assume that the health and the life of the user may be endangered.

Glossary

- 1) **Thermal resistance:** junction -ambient, mounted on PC-board (FR4), pads size 16 mm² each
- 2) **Thermal resistance:** junction - soldering point, of the device only, mounted on an ideal heatsink (e.g. metal block)
- 3) **Typical Values:** Due to the special conditions of the manufacturing processes of LED, the typical data or calculated correlations of technical parameters can only reflect statistical figures. These do not necessarily correspond to the actual parameters of each single product, which could differ from the typical data and calculated correlations or the typical characteristic line. If requested, e.g. because of technical improvements, these typ. data will be changed without any further notice.

Published by OSRAM Opto Semiconductors GmbH
Leibnizstraße 4, D-93055 Regensburg
www.osram-os.com © All Rights Reserved.

EU RoHS and China RoHS compliant product



此产品符合欧盟 RoHS 指令的要求；
按照中国的相关法规和标准，不含有毒有害物质或元素。

Компания «Океан Электроники» предлагает заключение долгосрочных отношений при поставках импортных электронных компонентов на взаимовыгодных условиях!

Наши преимущества:

- Поставка оригинальных импортных электронных компонентов напрямую с производств Америки, Европы и Азии, а так же с крупнейших складов мира;
- Широкая линейка поставок активных и пассивных импортных электронных компонентов (более 30 млн. наименований);
- Поставка сложных, дефицитных, либо снятых с производства позиций;
- Оперативные сроки поставки под заказ (от 5 рабочих дней);
- Экспресс доставка в любую точку России;
- Помощь Конструкторского Отдела и консультации квалифицированных инженеров;
- Техническая поддержка проекта, помощь в подборе аналогов, поставка прототипов;
- Поставка электронных компонентов под контролем ВП;
- Система менеджмента качества сертифицирована по Международному стандарту ISO 9001;
- При необходимости вся продукция военного и аэрокосмического назначения проходит испытания и сертификацию в лаборатории (по согласованию с заказчиком);
- Поставка специализированных компонентов военного и аэрокосмического уровня качества (Xilinx, Altera, Analog Devices, Intersil, Interpoint, Microsemi, Actel, Aeroflex, Peregrine, VPT, Syfer, Eurofarad, Texas Instruments, MS Kennedy, Miteq, Cobham, E2V, MA-COM, Hittite, Mini-Circuits, General Dynamics и др.);

Компания «Океан Электроники» является официальным дистрибьютором и эксклюзивным представителем в России одного из крупнейших производителей разъемов военного и аэрокосмического назначения «JONHON», а так же официальным дистрибьютором и эксклюзивным представителем в России производителя высокотехнологичных и надежных решений для передачи СВЧ сигналов «FORSTAR».



JONHON

«JONHON» (основан в 1970 г.)

Разъемы специального, военного и аэрокосмического назначения:

(Применяются в военной, авиационной, аэрокосмической, морской, железнодорожной, горно- и нефтедобывающей отраслях промышленности)

«FORSTAR» (основан в 1998 г.)

ВЧ соединители, коаксиальные кабели,
кабельные сборки и микроволновые компоненты:

(Применяются в телекоммуникациях гражданского и специального назначения, в средствах связи, РЛС, а так же военной, авиационной и аэрокосмической отраслях промышленности).



Телефон: 8 (812) 309-75-97 (многоканальный)

Факс: 8 (812) 320-03-32

Электронная почта: ocean@oceanchips.ru

Web: <http://oceanchips.ru/>

Адрес: 198099, г. Санкт-Петербург, ул. Калинина, д. 2, корп. 4, лит. А