

## Battery Backup Switching IC

### ■ GENERAL DESCRIPTION

The NJU7286 is a battery backup system IC with two regulators, two voltage detectors, a battery switching system and their control circuit. It switches the regulator output from main power supply source to the backup battery when it detects main power supply drop and also has two voltage detection outputs.

The NJU7286 employs an exclusive sequence on the battery switching system which reduces the battery operation. Combining the special sequence and its low operating current, it is well-suited for battery backup systems of DSC, DVC and other portable devices. The NJU7286 is available in small and thin packages of 8-lead MSOP (TVSP) and SSOP. And there are four voltage options available, as follow table.

### ■ PACKAGE OUTLINE



**NJU7286RB1**  
**(MSOP8 (VSP8))**

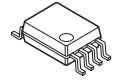

**NJU7286V**  
**(SSOP8)**

### ■ FEATURES

- Low Quiescent Current :12 $\mu$ A max. ( $V_{IN}$  =3.6V) / Normal operation  
:2.1 $\mu$ A max. ( $V_{BAT}$  =3.0V) / Backup
- Low Dropout Voltage :0.06V max. ( $I_{RO}$  =3mA) / REG1  
:0.3V max. ( $I_{OUT}$  =23mA) / REG2
- 2CH(REG1, REG2) Output Voltage : $\pm$ 2.0%
- 2CH( $\overline{CS}$ ,  $\overline{RESET}$ ) Output Voltage :  $\pm$  2.0%
- Exclusive Sequence
- Small Package SSOP8, MSOP8 (TVSP8)\*

\*MEET JEDEC MO-187-DA / THIN TYPE

### ■ PIN CONFIGURATION

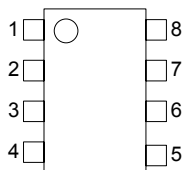

**MSOP8 (TVSP-8)**  
**SSOP-8**

1.  $V_{SS}$
2. NC
3.  $V_{BAT}$
4.  $\overline{CS}$
5.  $\overline{RESET}$
6.  $V_{OUT}$
7.  $V_{IN}$
8.  $V_{RO}$

# NJU7286

## SELECTION GUIDE

Device Name	Output Voltage (V)		CS Voltage (V)		RESET Voltage (V)		Switch Voltage (V)
	V <sub>RO</sub>	V <sub>OUT</sub>	-V <sub>DET1</sub>	+V <sub>DET1</sub>	-V <sub>DET2</sub>	+V <sub>DET2</sub>	V <sub>SW1</sub>
NJU7286A	3.200	3.200	3.300	3.401	2.400	2.528	+V <sub>DET1</sub> ×0.85
NJU7286B	3.150	3.150	4.200	4.305	2.300	2.420	+V <sub>DET1</sub> ×0.85
NJU7286C	3.300	3.300	3.800	3.903	2.100	2.230	+V <sub>DET1</sub> ×0.85
NJU7286D	3.200	3.200	3.300	3.401	2.250	2.362	+V <sub>DET1</sub> ×0.85

Caution: The NJU7286D is available in only MSOP8 (TVSP8).

CS voltage should be set up so that switch voltage (V<sub>SW1</sub>) may become more than RESET voltage (-V<sub>DET2</sub>).

Note: The selection range is as follows.

- V<sub>RO</sub>, V<sub>OUT</sub> : 2.3 to 5.4V (0.1V Step)
- V<sub>DET1</sub> : 2.4 to 5.4V (0.1V Step)
- V<sub>DET2</sub> : 1.7 to 3.4V (0.1V Step)
- V<sub>SW1</sub> : +V<sub>DET1</sub>×0.85

## ABSOLUTE MAXIMUM RATINGS

(Ta=25°C)

PARAMETER		SYMBOL	RATINGS	UNIT
Main Power Supply Input Voltage		V <sub>IN</sub>	+10	V
Backup Power Supply Input Voltage		V <sub>BAT</sub>	+10	V
Output Voltage of Voltage Regulator		V <sub>RO</sub> , V <sub>OUT</sub>	V <sub>SS</sub> -0.3 to V <sub>IN</sub> +0.3	V
Output Voltage	CS Output Voltage	V <sub>CS</sub>	V <sub>SS</sub> -0.3 to +10	V
	RESET Output Voltage	V <sub>RESET</sub>		V
Power Dissipation	SSOP-8	P <sub>D</sub>	250	mW
	MSOP8 (TVSP8)		320	
Operating Temperature		Topr	-40 to +85	°C
Storage Temperature		Tstg	-40 to +125	°C

## ■ ELECTRICAL CHARACTERISTICS

**NJU7286A** ( $C_{IN}=0.1\mu F$ ,  $C_{OV(OUT)}=10\mu F$ ,  $C_{OV(RO)}=10\mu F$ ,  $T_a=25^\circ C$ )

PARAMETER	SYMBOL	TEST CONDITION	MIN.	TYP.	MAX.	UNIT
<b>Total</b>						
Quiescent Current	$I_{SS1}$	$V_{IN}=3.6V$ , No-Load	-	4	12	$\mu A$
	$I_{BAT1}$	$V_{IN}=3.6V$ , $V_{BAT}=3.0V$ , No-Load	-	-	0.1	$\mu A$
	$I_{BAT2}$	$V_{IN}=OPEN$ , $V_{BAT}=3.0V$ , No-Load	-	1.0	2.1	$\mu A$
Backup Power Supply Input Voltage	$V_{BAT}$		2.0	-	4.0	V
<b>Voltage Regulator 1</b>						
Output Voltage 1	$V_{RO}$	$V_{IN}=7.2V$ , $I_{RO}=3mA$	3.136	3.200	3.264	V
Dropout Voltage 1	$\Delta V_{I-O1}$	$I_{RO}=3mA$	-	30	60	mV
Load Regulation 1A	$\Delta V_{ROA}/\Delta I_{RO}$	$V_{IN}=7.2V$ , $I_{RO}=0.1$ to 30mA	-	0.06	0.15	%/mA
Load Regulation 1B	$\Delta V_{ROB}/\Delta I_{RO}$	$V_{IN}=3.6V$ , $I_{RO}=0.1$ to 30mA	-	0.06	0.15	%/mA
Line Regulation 1	$\Delta V_{RO}/\Delta V_{IN}$	$V_{IN}=4$ to 9V, $I_{RO}=3mA$	-	-	0.2	%/V
Average Temperature Coefficient of Output Voltage 1	$\Delta V_{RO}/\Delta T$	$T_a=0^\circ C$ to $+85^\circ C$	-	$\pm 100$	-	ppm/ $^\circ C$
<b>Voltage Regulator 2</b>						
Output Voltage 2	$V_{OUT}$	$V_{IN}=7.2V$ , $I_{OUT}=23mA$	3.136	3.200	3.264	V
Dropout Voltage 2	$\Delta V_{I-O2}$	$I_{OUT}=23mA$	-	150	300	mV
Load Regulation 2A	$\Delta V_{OUTA}/\Delta I_{OUT}$	$V_{IN}=7.2V$ , $I_{OUT}=0.1$ to 60mA	-	0.04	0.1	%/mA
Load Regulation 2B	$\Delta V_{OUTB}/\Delta I_{OUT}$	$V_{IN}=3.6V$ , $I_{OUT}=0.1$ to 60mA	-	0.04	0.1	%/mA
Line Regulation 2	$\Delta V_{OUT}/\Delta V_{IN}$	$V_{IN}=4$ to 9V, $I_{OUT}=23mA$	-	-	0.2	%/V
Average Temperature Coefficient of Output Voltage 2	$\Delta V_{OUT}/\Delta T$	$T_a=0^\circ C$ to $+85^\circ C$	-	$\pm 100$	-	ppm/ $^\circ C$
<b>CS Voltage Detection</b>						
Detection Voltage 1	$-V_{DET1}$	Detection Voltage $V_{IN}$	3.234	3.300	3.366	V
Release Voltage 1	$+V_{DET1}$		3.319	3.401	3.482	V
Average Temperature Coefficient of Detection Voltage 1	$\Delta V_{DET1}/\Delta T$	$T_a=0^\circ C$ to $+85^\circ C$	-	$\pm 100$	-	ppm/ $^\circ C$
Output Current 1	$I_{SINK1}$	$V_{DS}=0.5V$ , $V_{IN}=V_{BAT}=2.0V$	1.50	2.30	-	mA
Leak Current 1	$I_{LEAK1}$	$V_{DS}=9V$ , $V_{IN}=9V$	-	-	0.1	$\mu A$
Operation Voltage 1	$V_{OPR1}$	$V_{IN}$ or $V_{BAT}$	1.7	-	9.0	V
<b>RESET Voltage Detection</b>						
Detection Voltage 2	$-V_{DET2}$	Detection Voltage $V_{OUT}$	2.351	2.400	2.449	V
Release Voltage 2	$+V_{DET2}$		2.457	2.528	2.599	V
Release Delay Time	$T_{DELAY}$		200	500	-	$\mu S$
Average Temperature Coefficient of Detection Voltage 2	$\Delta V_{DET2}/\Delta T$	$T_a=0^\circ C$ to $+85^\circ C$	-	$\pm 100$	-	ppm/ $^\circ C$
Output Current 2	$I_{SINK2}$	$V_{DS}=0.5V$ , $V_{IN}=V_{BAT}=2.0V$	1.50	2.30	-	mA
Leak Current 2	$I_{LEAK2}$	$V_{DS}=9V$ , $V_{IN}=9V$	-	-	0.1	$\mu A$
Operation Voltage 2	$V_{OPR2}$	$V_{IN}$ or $V_{BAT}$	1.7	-	9.0	V

# NJU7286

Switch Control						
Switch Voltage	$V_{SW1}$	$V_{BAT}=2.8V$ , Detection Voltage $V_{IN}$	$+V_{DET1}$ X0.83	$+V_{DET1}$ X0.85	$+V_{DET1}$ X0.87	V
CS Output Inhibit Voltage	$V_{SW2}$	$V_{BAT}=3.0V$ , Detection Voltage $V_{OUT}$	$V_{OUT}$ X0.93	$V_{OUT}$ X0.95	$V_{OUT}$ X0.97	V
$V_{BAT}$ Switch Leak Current	$I_{LEAK}$	$V_{IN}=3.6V$ , $V_{BAT}=0V$	-	-	0.1	$\mu A$
$V_{BAT}$ Switch Resistance	$R_{SW}$	$V_{IN}=OPEN$ , $V_{BAT}=3.0V$ , $I_{OUT}=10\sim 500\mu A$	-	30	60	$\Omega$
Average Temperature Coefficient of Switch Voltage	$\Delta V_{SW1}/\Delta T$	$T_a=0^{\circ}C$ to $+85^{\circ}C$	-	$\pm 100$	-	ppm/ $^{\circ}C$
Average Temperature Coefficient of CS Output Inhibit Voltage	$\Delta V_{SW2}/\Delta T$	$T_a=0^{\circ}C$ to $+85^{\circ}C$	-	$\pm 100$	-	ppm/ $^{\circ}C$

**NJU7286B** (C<sub>IN</sub>=0.1μF, C<sub>O(VOUT)</sub>=10μF, C<sub>O(VRO)</sub>=10μF, Ta=25°C)

PARAMETER	SYMBOL	TEST CONDITION	MIN.	TYP.	MAX.	UNIT
<b>Total</b>						
Quiescent Current	I <sub>SS1</sub>	V <sub>IN</sub> =6.0V, No-Load	-	4	12	μA
	I <sub>BAT1</sub>	V <sub>IN</sub> =6.0V, V <sub>BAT</sub> =3.0V, No-Load	-	-	0.1	μA
	I <sub>BAT2</sub>	V <sub>IN</sub> =OPEN, V <sub>BAT</sub> =3.0V, No-Load	-	1.0	2.1	μA
Backup Power Supply Input Voltage	V <sub>BAT</sub>		2.0	-	4.0	V
<b>Voltage Regulator 1</b>						
Output Voltage 1	V <sub>RO</sub>	V <sub>IN</sub> =6.0V, I <sub>RO</sub> =3mA	3.087	3.150	3.213	V
Dropout Voltage 1	ΔV <sub>I-O1</sub>	I <sub>RO</sub> =3mA	-	30	60	mV
Load Regulation 1	ΔV <sub>RO</sub> /ΔI <sub>RO</sub>	V <sub>IN</sub> =6.0V, I <sub>RO</sub> =0.1~30mA	-	0.06	0.15	%/mA
Line Regulation 1	ΔV <sub>RO</sub> /ΔV <sub>N</sub>	V <sub>IN</sub> =6~9V, I <sub>RO</sub> =3mA	-	-	0.2	%/V
Average Temperature Coefficient of Output Voltage 1	ΔV <sub>RO</sub> /ΔT	Ta=0°C to +85°C	-	±100	-	ppm/°C
<b>Voltage Regulator 2</b>						
Output Voltage 2	V <sub>OUT</sub>	V <sub>IN</sub> =6.0V, I <sub>OUT</sub> =23mA	3.087	3.150	3.213	V
Dropout Voltage 2	ΔV <sub>I-O2</sub>	I <sub>OUT</sub> =23mA	-	150	300	mV
Load Regulation 2	ΔV <sub>OUT</sub> /ΔI <sub>OUT</sub>	V <sub>IN</sub> =6.0V, I <sub>OUT</sub> =0.1 to 60mA	-	0.04	0.1	%/mA
Line Regulation 2	ΔV <sub>OUT</sub> /ΔV <sub>N</sub>	V <sub>IN</sub> =6 to 9V, I <sub>OUT</sub> =23mA	-	-	0.2	%/V
Average Temperature Coefficient of Output Voltage 2	ΔV <sub>OUT</sub> /ΔT	Ta=0°C to +85°C	-	±100	-	ppm/°C
<b>CS Voltage Detection</b>						
Detection Voltage 1	-V <sub>DET1</sub>	Detection Voltage V <sub>IN</sub>	4.116	4.200	4.284	V
Release Voltage 1	+V <sub>DET1</sub>		4.204	4.305	4.407	V
Average Temperature Coefficient of Detection Voltage 1	ΔV <sub>DET1</sub> /ΔT	Ta=0°C to +85°C	-	±100	-	ppm/°C
Output Current 1	I <sub>SINK1</sub>	V <sub>DS</sub> =0.5V, V <sub>IN</sub> =V <sub>BAT</sub> =2.0V	1.50	2.30	-	mA
Leak Current 1	I <sub>LEAK1</sub>	V <sub>DS</sub> =9V, V <sub>IN</sub> =9V	-	-	0.1	μA
Operation Voltage 1	V <sub>OPR1</sub>	V <sub>IN</sub> or V <sub>BAT</sub>	1.7	-	9.0	V
<b>RESET Voltage Detection</b>						
Detection Voltage 2	-V <sub>DET2</sub>	Detection Voltage V <sub>OUT</sub>	2.254	2.300	2.346	V
Release Voltage 2	+V <sub>DET2</sub>		2.348	2.420	2.492	V
Release Delay Time	T <sub>DELAY</sub>		200	500	-	μS
Average Temperature Coefficient of Detection Voltage 2	ΔV <sub>DET2</sub> /ΔT	Ta=0°C to +85°C	-	±100	-	ppm/°C
Output Current 2	I <sub>SINK2</sub>	V <sub>DS</sub> =0.5V, V <sub>IN</sub> =V <sub>BAT</sub> =2.0V	1.50	2.30	-	mA
Leak Current 2	I <sub>LEAK2</sub>	V <sub>DS</sub> =9V, V <sub>IN</sub> =9V	-	-	0.1	μA
Operation Voltage 2	V <sub>OPR2</sub>	V <sub>IN</sub> or V <sub>BAT</sub>	1.7	-	9.0	V

Switch Control						
Switch Voltage	$V_{SW1}$	$V_{BAT}=2.8V$ , Detection Voltage $V_{IN}$	$+V_{DET1}$ X0.83	$+V_{DET1}$ X0.85	$+V_{DET1}$ X0.87	V
CS Output Inhibit Voltage	$V_{SW2}$	$V_{BAT}=3.0V$ , Detection Voltage $V_{OUT}$	$V_{OUT}$ X0.93	$V_{OUT}$ X0.95	$V_{OUT}$ X0.97	V
$V_{BAT}$ Switch Leak Current	$I_{LEAK}$	$V_{IN}=6.0V$ , $V_{BAT}=0V$	-	-	0.1	$\mu A$
$V_{BAT}$ Switch Resistance	$R_{SW}$	$V_{IN}=OPEN$ , $V_{BAT}=3.0V$ , $I_{OUT}=10$ to $500\mu A$	-	30	60	$\Omega$
Average Temperature Coefficient of Switch Voltage	$\Delta V_{SW1}/\Delta T$	$T_a=0^{\circ}C$ to $+85^{\circ}C$	-	$\pm 100$	-	ppm/ $^{\circ}C$
Average Temperature Coefficient of CS Output Inhibit Voltage	$\Delta V_{SW2}/\Delta T$	$T_a=0^{\circ}C$ to $+85^{\circ}C$	-	$\pm 100$	-	ppm/ $^{\circ}C$

**NJU7286C** (C<sub>IN</sub>=0.1μF, C<sub>O(VOUT)</sub>=10μF, C<sub>O(VRO)</sub>=10μF, Ta=25°C)

PARAMETER	SYMBOL	TEST CONDITION	MIN.	TYP.	MAX.	UNIT
<b>Total</b>						
Quiescent Current	I <sub>SS1</sub>	V <sub>IN</sub> =6.0V, No-Load	-	4	12	μA
	I <sub>BAT1</sub>	V <sub>IN</sub> =6.0V, V <sub>BAT</sub> =3.0V, No-Load	-	-	0.1	μA
	I <sub>BAT2</sub>	V <sub>IN</sub> =OPEN, V <sub>BAT</sub> =3.0V, No-Load	-	1.0	2.1	μA
Backup Power Supply Input Voltage	V <sub>BAT</sub>		2.0	-	4.0	V
<b>Voltage Regulator 1</b>						
Output Voltage 1	V <sub>RO</sub>	V <sub>IN</sub> =6.0V, I <sub>RO</sub> =3mA	3.234	3.300	3.366	V
Dropout Voltage 1	ΔV <sub>I-O1</sub>	I <sub>RO</sub> =3mA	-	30	60	mV
Load Regulation 1	ΔV <sub>RO</sub> /ΔI <sub>RO</sub>	V <sub>IN</sub> =6.0V, I <sub>RO</sub> =0.1 to 30mA	-	0.06	0.15	%/mA
Line Regulation 1	ΔV <sub>RO</sub> /ΔV <sub>N</sub>	V <sub>IN</sub> =6 to 9V, I <sub>RO</sub> =3mA	-	-	0.2	%/V
Average Temperature Coefficient of Output Voltage 1	ΔV <sub>RO</sub> /ΔT	Ta=0°C to +85°C	-	±100	-	ppm/°C
<b>Voltage Regulator 2</b>						
Output Voltage 2	V <sub>OUT</sub>	V <sub>IN</sub> =6.0V, I <sub>OUT</sub> =23mA	3.234	3.300	3.366	V
Dropout Voltage 2	ΔV <sub>I-O2</sub>	I <sub>OUT</sub> =23mA	-	150	300	mV
Load Regulation 2	ΔV <sub>OUT</sub> /ΔI <sub>OUT</sub>	V <sub>IN</sub> =6.0V, I <sub>OUT</sub> =0.1 to 60mA	-	0.04	0.1	%/mA
Line Regulation 2	ΔV <sub>OUT</sub> /ΔV <sub>N</sub>	V <sub>IN</sub> =6 to 9V, I <sub>OUT</sub> =23mA	-	-	0.2	%/V
Average Temperature Coefficient of Output Voltage 2	ΔV <sub>OUT</sub> /ΔT	Ta=0°C to +85°C	-	±100	-	ppm/°C
<b>CS Voltage Detection</b>						
Detection Voltage 1	-V <sub>DET1</sub>	Detection Voltage V <sub>IN</sub>	3.724	3.800	3.876	V
Release Voltage 1	+V <sub>DET1</sub>		3.805	3.903	4.000	V
Average Temperature Coefficient of Detection Voltage 1	ΔV <sub>DET1</sub> /ΔT	Ta=0°C to +85°C	-	±100	-	ppm/°C
Output Current 1	I <sub>SINK1</sub>	V <sub>DS</sub> =0.5V, V <sub>IN</sub> =V <sub>BAT</sub> =2.0V	1.50	2.30	-	mA
Leak Current 1	I <sub>LEAK1</sub>	V <sub>DS</sub> =9V, V <sub>IN</sub> =9V	-	-	0.1	μA
Operation Voltage 1	V <sub>OPR1</sub>	V <sub>IN</sub> or V <sub>BAT</sub>	1.7	-	9.0	V
<b>RESET Voltage Detection</b>						
Detection Voltage 2	-V <sub>DET2</sub>	Detection Voltage V <sub>OUT</sub>	2.058	2.100	2.142	V
Release Voltage 2	+V <sub>DET2</sub>		2.158	2.230	2.302	V
Release Delay Time	T <sub>DELAY</sub>		200	500	-	μS
Average Temperature Coefficient of Detection Voltage 2	ΔV <sub>DET2</sub> /ΔT	Ta=0°C to +85°C	-	±100	-	ppm/°C
Output Current 2	I <sub>SINK2</sub>	V <sub>DS</sub> =0.5V, V <sub>IN</sub> =V <sub>BAT</sub> =2.0V	1.50	2.30	-	mA
Leak Current 2	I <sub>LEAK2</sub>	V <sub>DS</sub> =9V, V <sub>IN</sub> =9V	-	-	0.1	μA
Operation Voltage 2	V <sub>OPR2</sub>	V <sub>IN</sub> or V <sub>BAT</sub>	1.7	-	9.0	V

Switch Control						
Switch Voltage	$V_{SW1}$	$V_{BAT}=2.8V$ , Detection Voltage $V_{IN}$	$+V_{DET1}$ X0.83	$+V_{DET1}$ X0.85	$+V_{DET1}$ X0.87	V
CS Output Inhibit Voltage	$V_{SW2}$	$V_{BAT}=3.0V$ , Detection Voltage $V_{OUT}$	$V_{OUT}$ X0.93	$V_{OUT}$ X0.95	$V_{OUT}$ X0.97	V
$V_{BAT}$ Switch Leak Current	$I_{LEAK}$	$V_{IN}=6.0V$ , $V_{BAT}=0V$	-	-	0.1	$\mu A$
$V_{BAT}$ Switch Resistance	$R_{SW}$	$V_{IN}=OPEN$ , $V_{BAT}=3.0V$ , $I_{OUT}=10$ to $500\mu A$	-	30	60	$\Omega$
Average Temperature Coefficient of Switch Voltage	$\Delta V_{SW1}/\Delta T$	$T_a=0^{\circ}C$ to $+85^{\circ}C$	-	$\pm 100$	-	ppm/ $^{\circ}C$
Average Temperature Coefficient of CS Output Inhibit Voltage	$\Delta V_{SW2}/\Delta T$	$T_a=0^{\circ}C$ to $+85^{\circ}C$	-	$\pm 100$	-	ppm/ $^{\circ}C$



## NJU7286D (C<sub>IN</sub>=0.1μF, C<sub>O(VOUT)</sub>=10μF, C<sub>O(VRO)</sub>=10μF, Ta=25°C)

PARAMETER	SYMBOL	TEST CONDITION	MIN.	TYP.	MAX.	UNIT
<b>Total</b>						
Quiescent Current	I <sub>SS1</sub>	V <sub>IN</sub> =3.6V, No-Load	-	4	12	μA
	I <sub>BAT1</sub>	V <sub>IN</sub> =3.6V, V <sub>BAT</sub> =3.0V, No-Load	-	-	0.1	μA
	I <sub>BAT2</sub>	V <sub>IN</sub> =OPEN, V <sub>BAT</sub> =3.0V, No-Load	-	1.0	2.1	μA
Backup Power Supply Input Voltage	V <sub>BAT</sub>		2.0	-	4.0	V
<b>Voltage Regulator 1</b>						
Output Voltage 1	V <sub>RO</sub>	V <sub>IN</sub> =7.2V, I <sub>RO</sub> =3mA	3.136	3.200	3.264	V
Dropout Voltage 1	ΔV <sub>I-O1</sub>	I <sub>RO</sub> =3mA	-	30	60	mV
Load Regulation 1A	ΔV <sub>ROA</sub> /ΔI <sub>RO</sub>	V <sub>IN</sub> =7.2V, I <sub>RO</sub> =0.1 to 30mA	-	0.06	0.15	%/mA
Load Regulation 1B	ΔV <sub>ROB</sub> /ΔI <sub>RO</sub>	V <sub>IN</sub> =3.6V, I <sub>RO</sub> =0.1 to 30mA	-	0.06	0.15	%/mA
Line Regulation 1	ΔV <sub>RO</sub> /ΔV <sub>N</sub>	V <sub>IN</sub> =4 to 9V, I <sub>RO</sub> =3mA	-	-	0.2	%/V
Average Temperature Coefficient of Output Voltage 1	ΔV <sub>RO</sub> /ΔT	Ta=0°C to +85°C	-	±100	-	ppm/°C
<b>Voltage Regulator 2</b>						
Output Voltage 2	V <sub>OUT</sub>	V <sub>IN</sub> =7.2V, I <sub>OUT</sub> =23mA	3.136	3.200	3.264	V
Dropout Voltage 2	ΔV <sub>I-O2</sub>	I <sub>OUT</sub> =23mA	-	150	300	mV
Load Regulation 2A	ΔV <sub>OUTA</sub> /ΔI <sub>OUT</sub>	V <sub>IN</sub> =7.2V, I <sub>OUT</sub> =0.1 to 60mA	-	0.04	0.1	%/mA
Load Regulation 2B	ΔV <sub>OUTB</sub> /ΔI <sub>OUT</sub>	V <sub>IN</sub> =3.6V, I <sub>OUT</sub> =0.1 to 60mA	-	0.04	0.1	%/mA
Line Regulation 2	ΔV <sub>OUT</sub> /ΔV <sub>N</sub>	V <sub>IN</sub> =4 to 9V, I <sub>OUT</sub> =23mA	-	-	0.2	%/V
Average Temperature Coefficient of Output Voltage 2	ΔV <sub>OUT</sub> /ΔT	Ta=0°C to +85°C	-	±100	-	ppm/°C
<b>CS Voltage Detection</b>						
Detection Voltage 1	-V <sub>DET1</sub>	Detection Voltage V <sub>IN</sub>	3.234	3.300	3.366	V
Release Voltage 1	+V <sub>DET1</sub>		3.319	3.401	3.482	V
Average Temperature Coefficient of Detection Voltage 1	ΔV <sub>DET1</sub> /ΔT	Ta=0°C to +85°C	-	±100	-	ppm/°C
Output Current 1	I <sub>SINK1</sub>	V <sub>DS</sub> =0.5V, V <sub>IN</sub> =V <sub>BAT</sub> =2.0V	1.50	2.30	-	mA
Leak Current 1	I <sub>LEAK1</sub>	V <sub>DS</sub> =9V, V <sub>IN</sub> =9V	-	-	0.1	μA
Operation Voltage 1	V <sub>OPR1</sub>	V <sub>IN</sub> or V <sub>BAT</sub>	1.7	-	9.0	V
<b>RESET Voltage Detection</b>						
Detection Voltage 2	-V <sub>DET2</sub>	Detection Voltage V <sub>OUT</sub>	2.205	2.250	2.295	V
Release Voltage 2	+V <sub>DET2</sub>		2.298	2.362	2.426	V
Release Delay Time	T <sub>DELAY</sub>		200	500	-	μS
Average Temperature Coefficient of Detection Voltage 2	ΔV <sub>DET2</sub> /ΔT	Ta=0°C to +85°C	-	±100	-	ppm/°C
Output Current 2	I <sub>SINK2</sub>	V <sub>DS</sub> =0.5V, V <sub>IN</sub> =V <sub>BAT</sub> =2.0V	1.50	2.30	-	mA
Leak Current 2	I <sub>LEAK2</sub>	V <sub>DS</sub> =9V, V <sub>IN</sub> =9V	-	-	0.1	μA
Operation Voltage 2	V <sub>OPR2</sub>	V <sub>IN</sub> or V <sub>BAT</sub>	1.7	-	9.0	V

# NJU7286

Switch Control						
Switch Voltage	$V_{SW1}$	$V_{BAT}=2.8V$ , Detection Voltage $V_{IN}$	$+V_{DET1}$ X0.83	$+V_{DET1}$ X0.85	$+V_{DET1}$ X0.87	V
CS Output Inhibit Voltage	$V_{SW2}$	$V_{BAT}=3.0V$ , Detection Voltage $V_{OUT}$	$V_{OUT}$ X0.93	$V_{OUT}$ X0.95	$V_{OUT}$ X0.97	V
$V_{BAT}$ Switch Leak Current	$I_{LEAK}$	$V_{IN}=3.6V$ , $V_{BAT}=0V$	-	-	0.1	$\mu A$
$V_{BAT}$ Switch Resistance	$R_{SW}$	$V_{IN}=OPEN$ , $V_{BAT}=3.0V$ , $I_{OUT}=10$ to $500\mu A$	-	30	60	$\Omega$
Average Temperature Coefficient of Switch Voltage	$\Delta V_{SW1}/\Delta T$	$T_a=0^{\circ}C$ to $+85^{\circ}C$	-	$\pm 100$	-	ppm/ $^{\circ}C$
Average Temperature Coefficient of CS Output Inhibit Voltage	$\Delta V_{SW2}/\Delta T$	$T_a=0^{\circ}C$ to $+85^{\circ}C$	-	$\pm 100$	-	ppm/ $^{\circ}C$

## ■ CAUTION ON USE

- Wiring of a power supply should lower impedance using thick wiring.  
Especially  $V_{IN}$  wiring needs to cautions, because the output current of the regulator flows.
- $I_{RO}$  or  $I_{OUT}$  should be set  $10\mu A$  or more. because output voltage rises and a load regulation becomes unstable.
- IC or the capacitor which are connected to the NJU7286 should not exceed rating by the exaggerated shot of a regulator etc.
- The  $V_{IN}$  terminal, the  $V_{OUT}$  terminal and the  $V_{RO}$  terminal should surely connect the capacitor between  $V_{SS}$ .  
The capacitor connected to the  $V_{OUT}$  terminal should connect the capacity of  $10\mu F$  or more. Because, in order to prevent carrying out voltage descending at the time of a REG2 operation change.
- External parts should connect near the NJU7286.
- If  $\overline{RESET}$  voltage detection becomes active, it will shift to special sequence from usually sequence. In order to suppress generating of an under shot etc.  $V_{OUT}$  terminal should connect the capacity of the suitable value.
- When bringing down  $V_{IN}$  to  $0V$ , the circumference circuit of the NJU7286 should design so that  $V_{IN}$  may fall over the time for  $10ms$  or more. In the case of less than  $10ms$ ,  $\overline{RESET}$  output is set to "L".
- Power dissipation should use in the range which is not exceeded.

## ■ BLOCK DIAGRAM

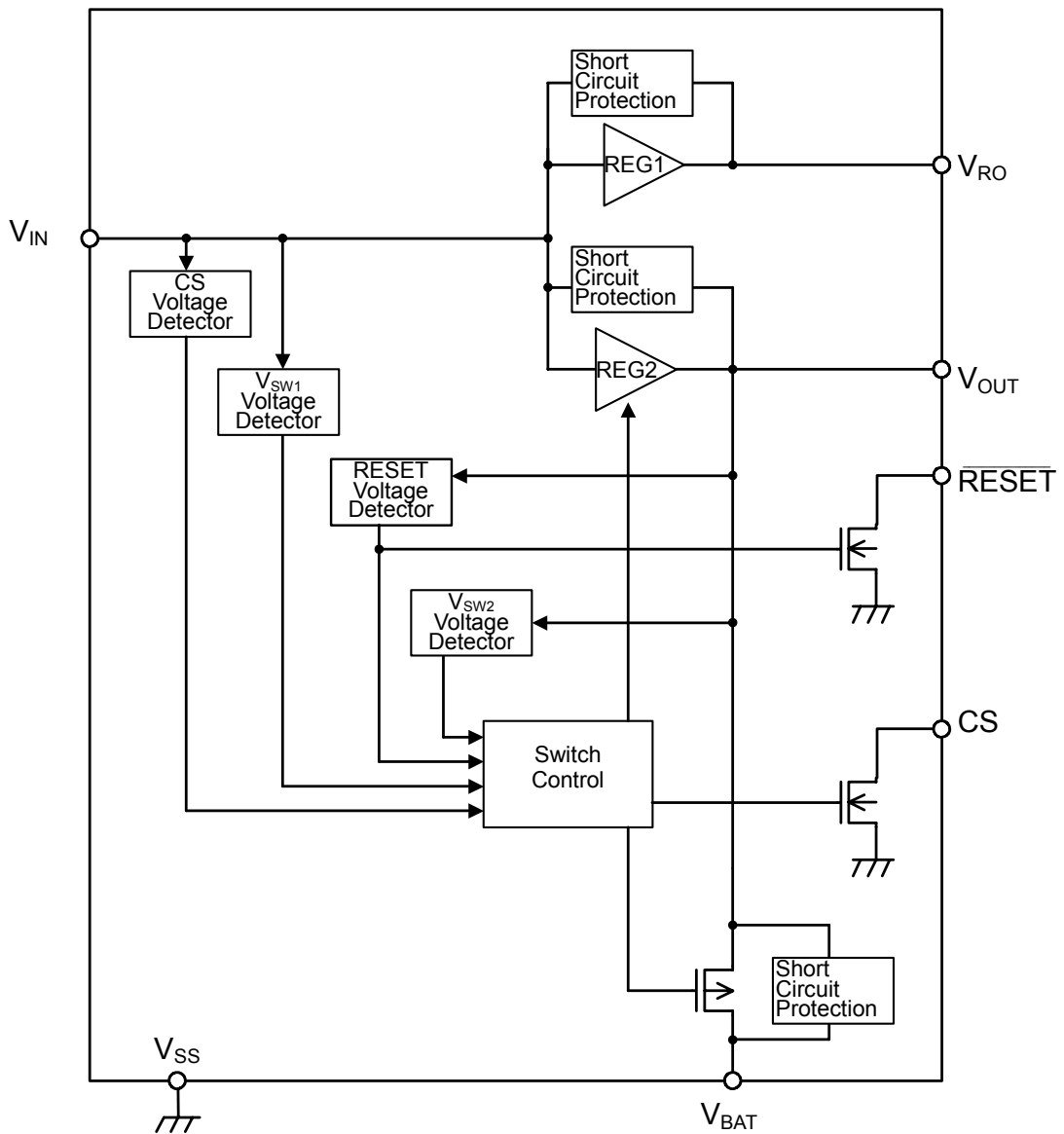

## ■ FUNCTIONAL EXPLANATION OF BLOCK

1. Voltage regulator(REG1,REG2)
  - Output Voltage serialization is possible with 0.1V step.
2. CS Voltage Detector
  - $V_{IN}$  (main power supply) terminal voltage is supervised, and the fall of the main power supply is detected.
  - Detection result is outputted to CS terminal as follows. (At the time of CS release permission signal output.)
    - Detection voltage( $-V_{DET1}$ ) or less : "L" Output
    - More than release voltage( $+V_{DET1}$ ) : "H" Output
  - power supply supplies from two terminals of  $V_{IN}$  and  $V_{BAT}$ .
3.  $\overline{RESET}$  Voltage Detector
  - $\overline{RESET}$  Voltage Detector supervises the voltage of a  $V_{OUT}$  terminal.
  - Detection result is outputted to  $\overline{RESET}$  terminal as follows.
    - Detection voltage( $-V_{DET1}$ ) or less : "L" Output
    - More than release voltage( $+V_{DET1}$ ) : "H" Output
  - power supply supplies from  $V_{OUT}$  terminals.(Normal logic will be outputted if  $V_{OUT}$  terminal voltage is more than 1.0V.)
4.  $V_{SW1}$  Voltage Detector
  - $V_{SW1}$  voltage detector supervises  $V_{IN}$  voltage.
  - Detection voltage ( $V_{SW1}$ ) follows the setting value of CS detection voltage.
5.  $V_{SW2}$  Voltage Detector
  - $V_{SW2}$  voltage detector supervises  $V_{IN}$  voltage.
  - CS release permission signal is as follows with  $V_{OUT}$  terminal voltage.
    - The output voltage  $V_{OUT}$  of REG2 is 95% or more of spec. : CS release permission signal is outputted.
    - The output voltage  $V_{OUT}$  of REG2 is 95% or less of spec. : CS release permission signal is stopped.
  - The CS release permission signal is as follows.
    - CS release permission voltage or less : CS terminal is "L" Fix.
    - More than CS release permission voltage : CS terminal outputs CS detection result.
    - (If  $V_{IN}$  terminal voltage is more than CS detection voltage even if  $V_{OUT}$  terminal voltage falls below on  $V_{SW2}$  voltage, CS output will maintain "H".)
6. Sequence explanation
  - Special sequence
    - Special sequence is until  $V_{IN}$  voltage rises from 0V and CS output is set to "H".
    - When the voltage of  $V_{OUT}$  falls and a  $\overline{RESET}$  output is set to the "L" level.
    - The period of a special sequence fixes  $V_{OUT}$  output to REG2.
  - Usual sequence
    - Usual sequence is until  $V_{IN}$  voltage rises and  $\overline{RESET}$  output is set to the "L" level.
    - The period of the usual sequence switches  $V_{OUT}$  output to REG2 or  $V_{BAT}$  by the detection result of the  $V_{SW1}$  detection circuit which is supervising  $V_{IN}$  voltage.

Terminal voltage	REG2 operation state	$V_{OUT}$ output	State of operation
$0V \text{ to } V_{IN} < +V_{DET1}$	ON	REG2	Special sequence
$V_{IN} > +V_{SW1}$	ON	REG2	Usual sequence
$V_{IN} \leq +V_{SW1}$	OFF	$V_{BAT} - \Delta VT1$	Usual sequence
$V_{OUT} > -V_{DET2}$	ON	REG2	Special sequence

$\Delta VT1$  : VDS of the switch transistor between  $V_{BAT} - V_{OUT}$ .

Note : Before REG2 turns on from OFF, it will take the time of 100 $\mu$ s by the longest. In the meantime,  $V_{OUT}$  may become high impedance. In order to prevent voltage descending, the  $V_{OUT}$  terminal should connect the capacitor of 10 $\mu$ F or more.

## ■ Timing Chart

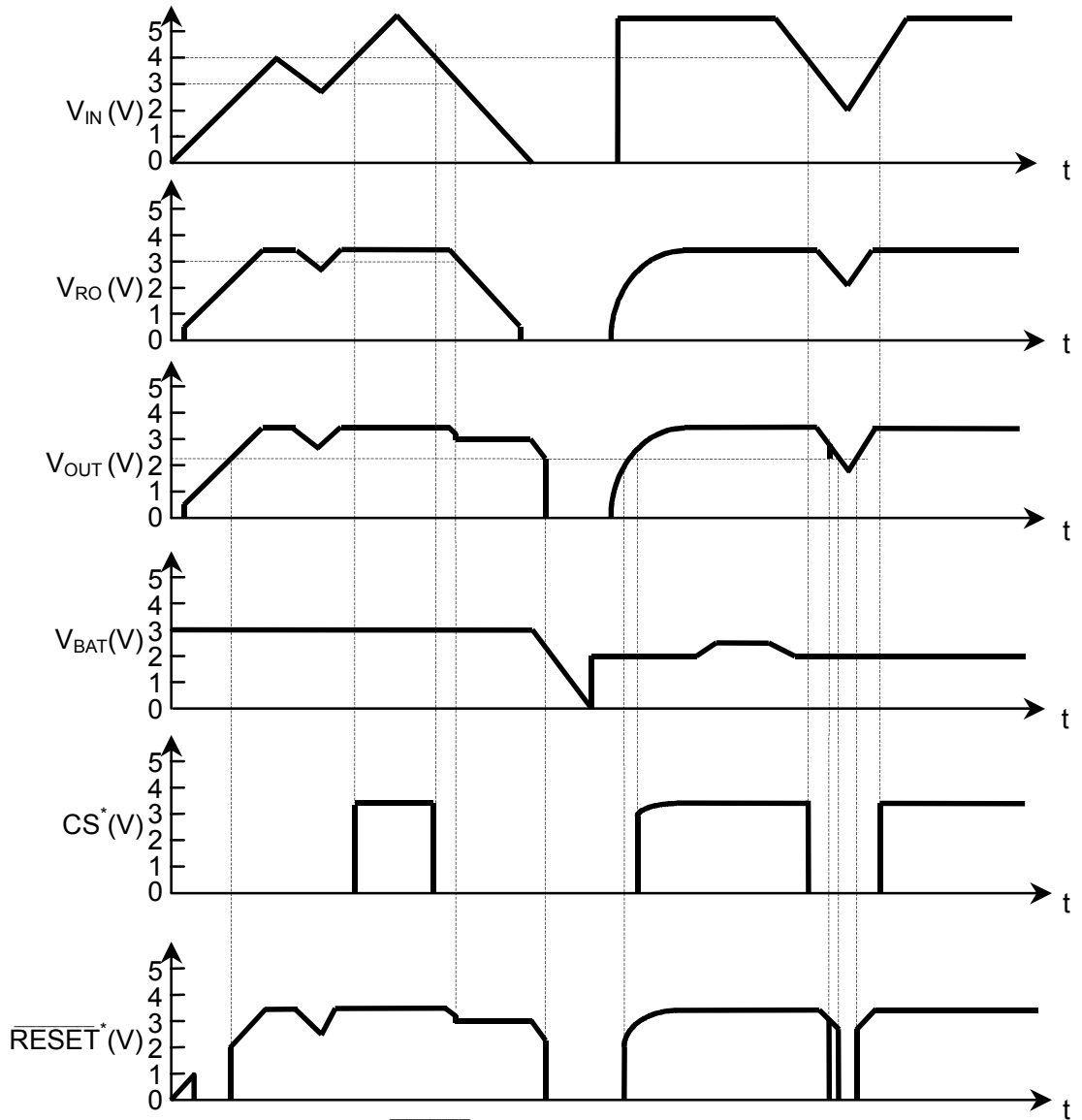

\* $CS$  and  $\overline{RESET}$  are pulled up to  $V_{OUT}$ .

# NJU7286

## TEST CIRCUIT

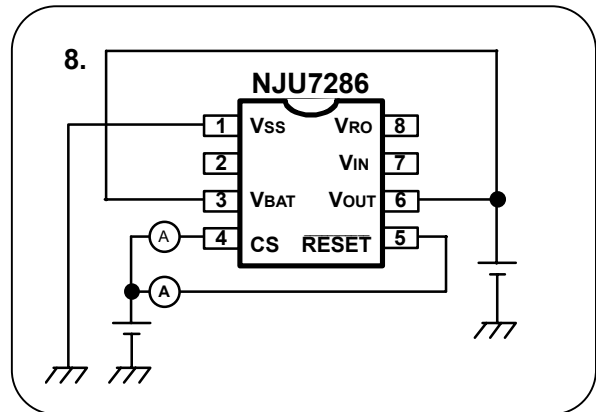
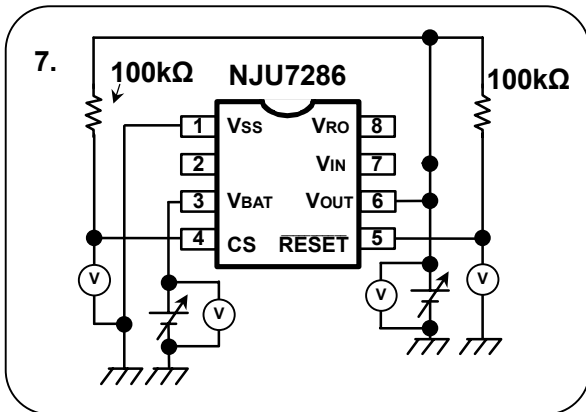
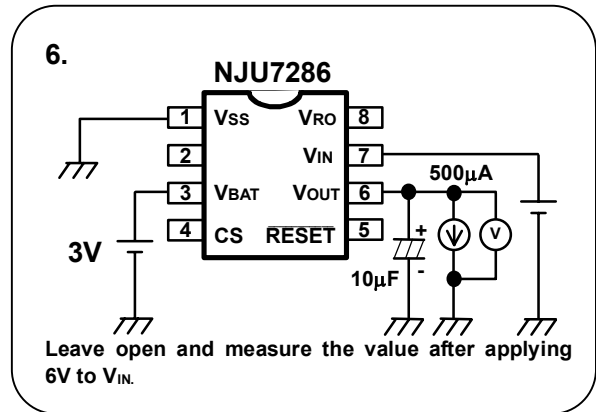
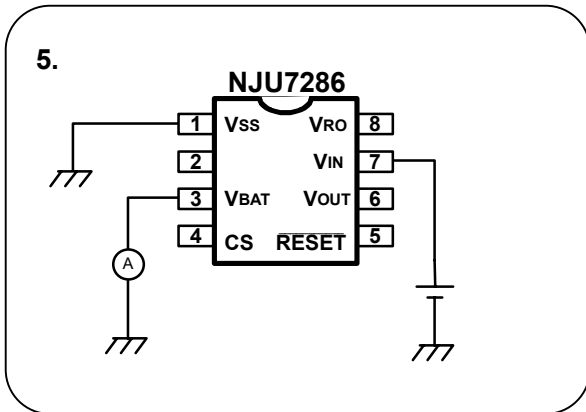
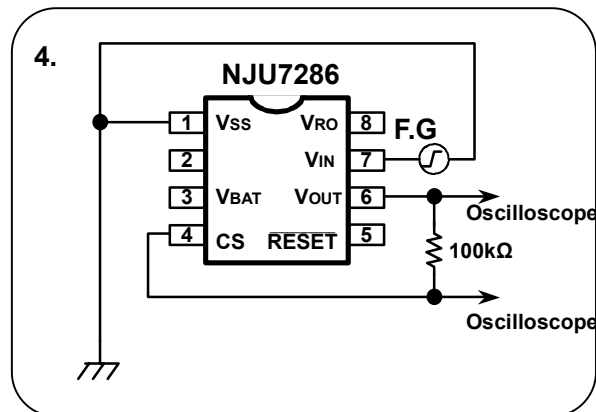
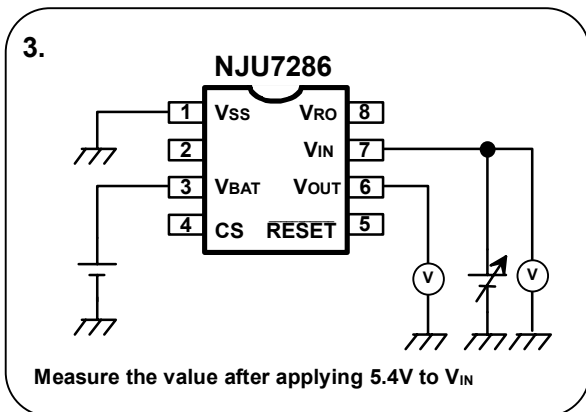
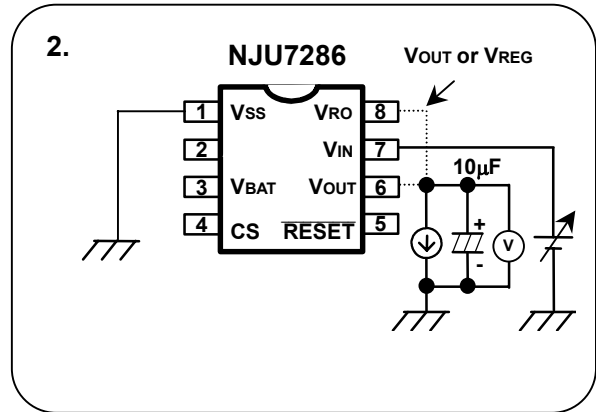
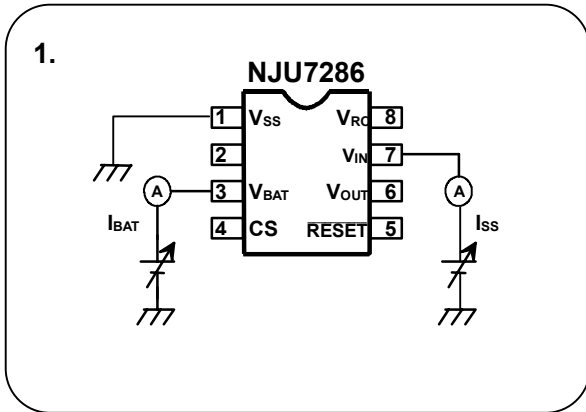

## ■ CORRESPOND TABLE OF TEST CIRCUIT

TEST PARAMETER	TEST CIRCUIT NUMBER
Quiescent Current	1
Power Supply Voltage Operation Range	2,7
Output Voltage 1	2
Dropout Voltage 1	2
Load Regulation 1	2
Line Regulation 1	2
Average Temperature Coefficient of Output Voltage 1	2
Output Voltage 2	2
Dropout Voltage 2	2
Load Regulation 2	2
Line Regulation 2	2
Average Temperature Coefficient of Output Voltage 2	2
Switch Voltage	3
Average Temperature Coefficient of Switch Voltage	3
Average Temperature Coefficient of INT release permission voltage	4
INT release permission voltage	4
V <sub>BAT</sub> Switch Leak Current	5
V <sub>BAT</sub> Switch Resistance	6
Backup Power Supply Input Voltage	6
INT Detection Voltage	7
INT Release voltage	7
Detection Voltage 1	7
Release voltage 1	7
Detection Voltage 2	7
Release voltage 2	7
Operation Voltage	7
Average Temperature Coefficient of Detection Voltage	7
Output Current	8
Leak Current	8

# NJU7286

## ■ TYPICAL APPLICATIONS

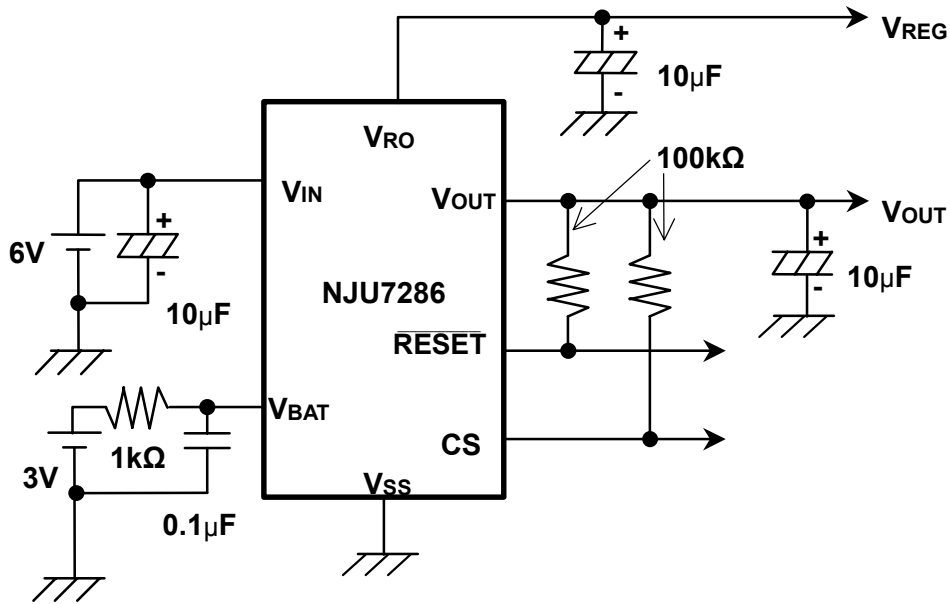

When the rechargeable battery is used as the backup battery.

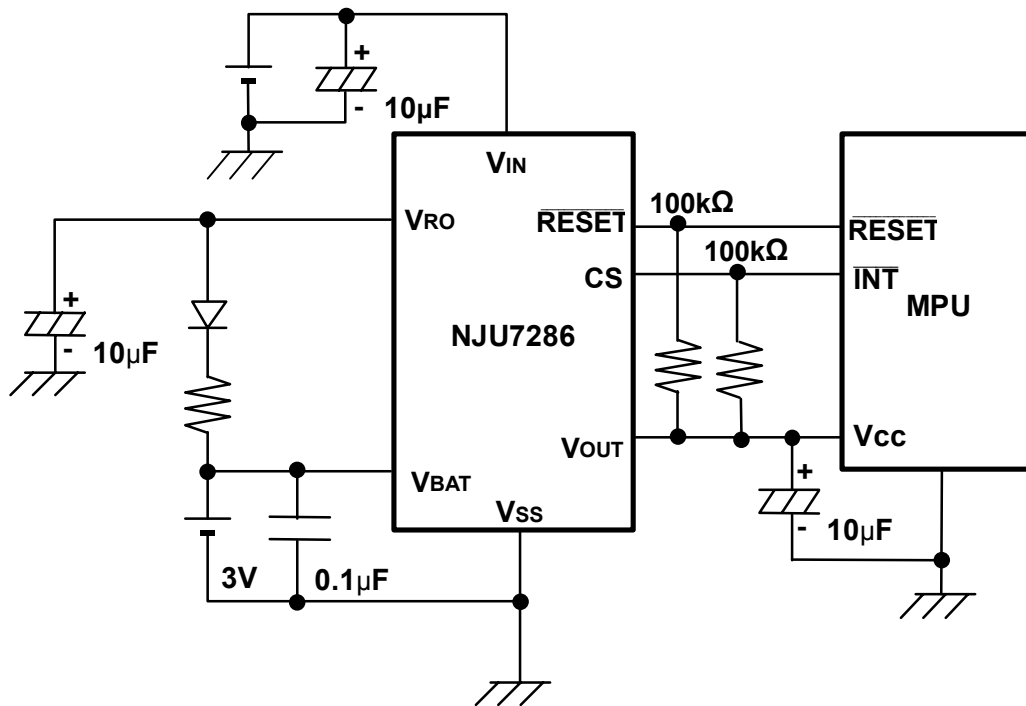

The backup battery can be flating-recharged by using voltage regulator 1.



**[CAUTION]**

The specifications on this databook are only given for information, without any guarantee as regards either mistakes or omissions. The application circuits in this databook are described only to show representative usages of the product and not intended for the guarantee or permission of any right including the industrial rights.

# Mouser Electronics

Authorized Distributor

Click to View Pricing, Inventory, Delivery & Lifecycle Information:

[NJR:](#)

[NJU7286AV-TE1](#) [NJU7286ARB1-TE2](#)

Компания «Океан Электроники» предлагает заключение долгосрочных отношений при поставках импортных электронных компонентов на взаимовыгодных условиях!

Наши преимущества:

- Поставка оригинальных импортных электронных компонентов напрямую с производств Америки, Европы и Азии, а так же с крупнейших складов мира;
- Широкая линейка поставок активных и пассивных импортных электронных компонентов (более 30 млн. наименований);
- Поставка сложных, дефицитных, либо снятых с производства позиций;
- Оперативные сроки поставки под заказ (от 5 рабочих дней);
- Экспресс доставка в любую точку России;
- Помощь Конструкторского Отдела и консультации квалифицированных инженеров;
- Техническая поддержка проекта, помощь в подборе аналогов, поставка прототипов;
- Поставка электронных компонентов под контролем ВП;
- Система менеджмента качества сертифицирована по Международному стандарту ISO 9001;
- При необходимости вся продукция военного и аэрокосмического назначения проходит испытания и сертификацию в лаборатории (по согласованию с заказчиком);
- Поставка специализированных компонентов военного и аэрокосмического уровня качества (Xilinx, Altera, Analog Devices, Intersil, Interpoint, Microsemi, Actel, Aeroflex, Peregrine, VPT, Syfer, Eurofarad, Texas Instruments, MS Kennedy, Miteq, Cobham, E2V, MA-COM, Hittite, Mini-Circuits, General Dynamics и др.);

Компания «Океан Электроники» является официальным дистрибьютором и эксклюзивным представителем в России одного из крупнейших производителей разъемов военного и аэрокосмического назначения «JONHON», а так же официальным дистрибьютором и эксклюзивным представителем в России производителя высокотехнологичных и надежных решений для передачи СВЧ сигналов «FORSTAR».



## JONHON

«JONHON» (основан в 1970 г.)

Разъемы специального, военного и аэрокосмического назначения:

(Применяются в военной, авиационной, аэрокосмической, морской, железнодорожной, горно- и нефтедобывающей отраслях промышленности)

«FORSTAR» (основан в 1998 г.)

ВЧ соединители, коаксиальные кабели,  
кабельные сборки и микроволновые компоненты:

(Применяются в телекоммуникациях гражданского и специального назначения, в средствах связи, РЛС, а так же военной, авиационной и аэрокосмической отраслях промышленности).



Телефон: 8 (812) 309-75-97 (многоканальный)

Факс: 8 (812) 320-03-32

Электронная почта: [ocean@oceanchips.ru](mailto:ocean@oceanchips.ru)

Web: <http://oceanchips.ru/>

Адрес: 198099, г. Санкт-Петербург, ул. Калинина, д. 2, корп. 4, лит. А