



The Infinite Bandwidth Company™

MIC59P60

8-Bit Serial-Input Protected Latched Driver

General Description

The MIC59P60 serial-input latched driver is a high-voltage (80V), high-current (500mA) integrated circuit comprised of eight CMOS data latches, a bipolar Darlington transistor driver for each latch, and CMOS control circuitry for the common CLEAR, STROBE, CLOCK, SERIAL DATA INPUT, and OUTPUT ENABLE functions. Similar to the MIC5842, additional protection circuitry supplied on this device includes thermal shutdown, under voltage lockout (UVLO), and over-current shutdown.

The bipolar/CMOS combination provides an extremely low-power latch with maximum interface flexibility. The MIC59P60 has open-collector outputs capable of sinking 500mA and integral diodes for inductive load transient suppression with a minimum output breakdown voltage rating of 80V (50V sustaining). The drivers can be operated with a split supply, where the negative supply is down to -20V and may be paralleled for higher load current capability.

Using a 5V logic supply, the MIC59P60 will typically operate at better than 5MHz. With a 12V logic supply, significantly higher speeds are obtained. The CMOS inputs are compatible with standard CMOS, PMOS, and NMOS circuits. TTL circuits may require pull-up resistors. By using the serial data output, drivers may be cascaded for interface applications requiring additional drive lines.

Each of these eight outputs has an independent over current shutdown of 500 mA. Upon over-current shutdown, the affected channel will turn OFF and the flag will go low until V_{DD} is cycled or the ENABLE/RESET pin is pulsed high. Current pulses less than 2μs will not activate current shutdown. Temperatures above 165°C will shut down the device and activate the error flag. The UVLO circuit prevents operation at low V_{DD} ; hysteresis of 0.5V is provided.

Features

- 3.3 MHz Minimum Data-Input Rate
- Output Current Shutdown (500mA Typical)
- Under Voltage Lockout
- Thermal Shutdown
- Output Fault Flag
- CMOS, PMOS, NMOS, and TTL Compatible
- Internal Pull-Up/Pull-Down Resistors
- Low Power CMOS Logic and Latches
- High Voltage Current Sink Outputs
- Output Transient-Protection Diodes
- Single or Split Supply Operation

Ordering Information

Part Number	Temperature Range	Package
MIC59P60BN	-40°C to +85°C	20-Pin Plastic DIP
MIC59P60BV	-40°C to +85°C	20-Pin PLCC
MIC59P60BWM	-40°C to +85°C	20-Pin Wide SOIC

Functional Diagram

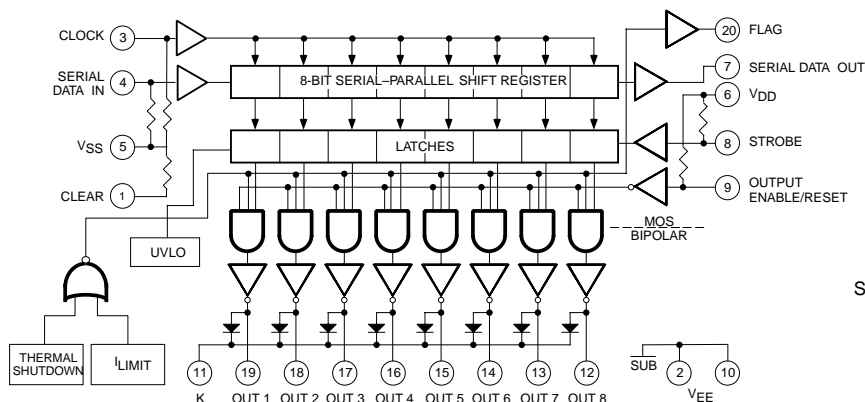

Pin Configuration

(DIP and SOIC)

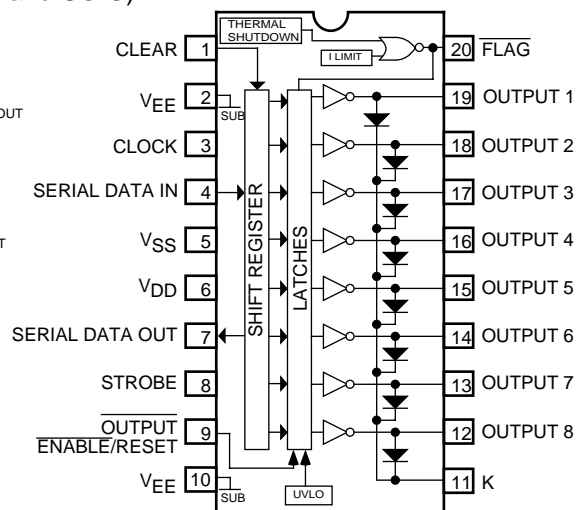

PLCC Pin Configuration

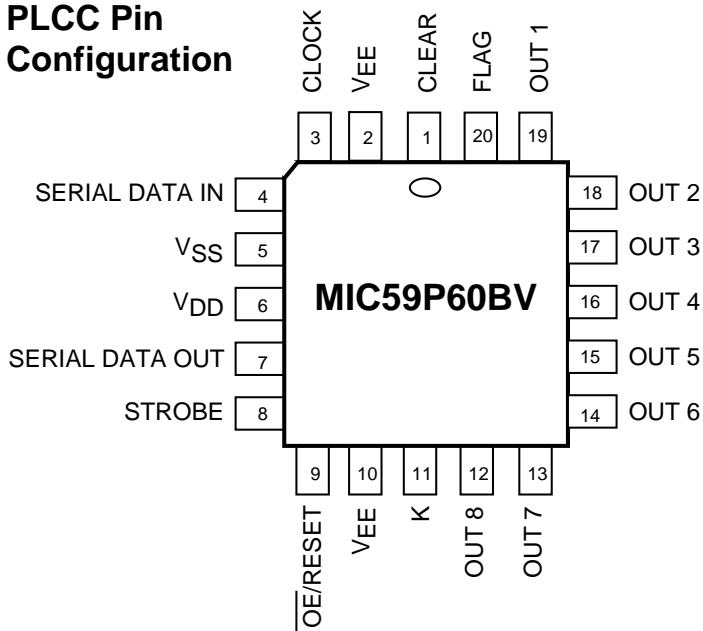

Typical Inputs

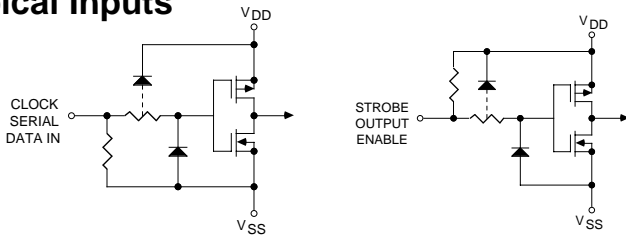

Typical Output Driver

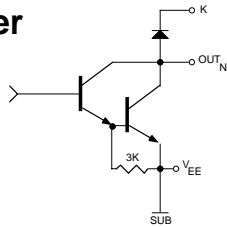

Pin Description

Pin	Name	Description
1	CLEAR	Sets All Latches OFF (open).
2,10	V _{EE}	Output Ground (Substrate). Most negative voltage in the system connects here.
3	CLOCK	Serial Data Clock. A CLEAR must also be clocked into the latches.
4	SERIAL DATA IN	Serial Data Input pin.
5	V _{SS}	Logic reference (Ground) pin.
6	V _{DD}	Logic Positive Supply voltage.
7	SERIAL DATA OUT	Serial Data Output pin. (Flow through).
8	STROBE	Output Strobe pin. Loads output latches when High. A STROBE is needed to CLEAR latches.
9	OUTPUT ENABLE/RESET	When Low, Outputs are active. When High, device is inactive and reset from a fault condition. An under voltage condition emulates a high OE/RESET input.
11	K	Transient suppression diode's cathode common pin.
12—19	OUTPUT N	Open Collector outputs 8 through 1.
20	FLAG	Error Flag. Open-collector output is Low upon Overcurrent Fault or Overtemperature fault. OUTPUT ENABLE/RESET must be pulled high to reset the flag and fault condition.

Absolute Maximum Ratings $V_{SS} = 0; T_A = 25^\circ\text{C}$

Output Voltage (V_{CE})	80V
Output Voltage ($V_{CE(SUS)}$)	50V, Note 1
V_{DD} with Reference to V_{SS}	15V
V_{DD} with Reference to V_{EE}	25V
Emitter Supply Voltage (V_{EE})	-20V
Input Voltage (V_{IN})	-0.3V to $V_{DD}+0.3V$
Protected Current	1.5A, Note 2
Power Dissipation (P_D)	
Plastic DIP (N)	2.0W
Derate above $T_A = +25^\circ\text{C}$	20mW/ $^\circ\text{C}$
PLCC (V)	1.4W
Derate above $T_A = +25^\circ\text{C}$	14mW/ $^\circ\text{C}$
Wide SOIC (WM)	1.2W
Derate above $T_A = +25^\circ\text{C}$	12mW/ $^\circ\text{C}$
Operating Temperature (T_A)	
Plastic DIP (N), PLCC (V), SOIC (WM)	-40 $^\circ\text{C}$ to +85 $^\circ\text{C}$
Storage Temperature (T_S)	-65 $^\circ\text{C}$ to +150 $^\circ\text{C}$
Junction Temperature (T_J)	+150 $^\circ\text{C}$
ESD	Note 3

Note 1: For inductive load applications.

Note 2: Each channel. V_{EE} connection must be designed to minimize inductance and resistance.

Note 3: Devices are input-static protected but can be damaged by extremely high static charges.

Electrical Characteristics

$V_{DD} = 5V$, $V_{SS} = V_{EE} = 0V$; $T_A = +25^\circ C$; unless noted.

Characteristic	Symbol	Test Conditions	Limits			Unit
			Min.	Typ.	Max.	
Output Leakage Current	I_{CEX}	$V_{OUT} = 80V$ $V_{OUT} = 80V, T_A = +70^\circ C$		100	50	μA
Collector-Emitter Saturation Voltage	$V_{CE(SAT)}$	$I_{OUT} = 100mA$ $I_{OUT} = 200mA$ $I_{OUT} = 350mA$		0.9 1.1 1.3	1.1 1.3 1.6	V
Collector-Emitter Sustaining Voltage	$V_{CE(SUS)}$	$I_{OUT} = 350mA, L = 2mH$	50			V
Input Voltage	$V_{IN(0)}$				1.0	V
	$V_{IN(1)}$	$V_{DD} = 12V$ $V_{DD} = 10V$ $V_{DD} = 5.0V, \text{Note 4}$	10.5 8.5 3.5			V
Input Resistance	R_{IN}	$V_{DD} = 12V$ $V_{DD} = 10V$ $V_{DD} = 5.0V$	50 50 50	200 300 600		$k\Omega$
Flag Output Current	I_{OL}	$V_{OL} = 0.4V$		15		mA
Flag Output Leakage	I_{OH}	$V_{OH} = 12.0V$		50		nA
Supply Current	$I_{DD(ON)}$	All Drivers ON, $V_{DD} = 12V$ All Drivers ON, $V_{DD} = 10V$ All Drivers ON, $V_{DD} = 5.0V$		6.4 6.0 4.6	10.0 9.0 7.5	mA
	$I_{DD(1\text{ OUTPUT})}$	One Driver ON, All others OFF, $V_{DD} = 12V$ One Driver ON, All others OFF, $V_{DD} = 10V$ One Driver ON, All others OFF, $V_{DD} = 5V$		3.1 2.9 2.3	4.5 4.5 3.6	mA
	$I_{DD(OFF)}$	All Drivers OFF, $V_{DD} = 12V$ All Drivers OFF, $V_{DD} = 10V$ All Drivers OFF, $V_{DD} = 5.0V$		2.6 2.4 1.9	4.2 3.6 3.0	mA
Clamp Diode Leakage Current	I_R	$V_R = 80V$			50	μA
Clamp Diode Forward Voltage	V_F	$I_F = 350mA$		1.7	2.0	V
Over Current Shutdown Threshold	I_{LIM}			500		mA
Start Up Voltage	V_{SU}	Note 5	3.5	4.0	4.5	V
Minimum Supply (V_{DD})	$V_{DD\text{ MIN}}$		3.0	3.5	4.0	V
Thermal Shutdown				165		$^\circ C$
Thermal Shutdown Hysteresis				10		$^\circ C$

Note 4: Operation of these devices with standard TTL or DTL may require the use of appropriate pull-up resistors to insure a minimum logic "1".

Note 5: Undervoltage lockout is guaranteed to release device at no more than 4.5V, and disable the device at no less than 3.0V

Typical Characteristic Curves

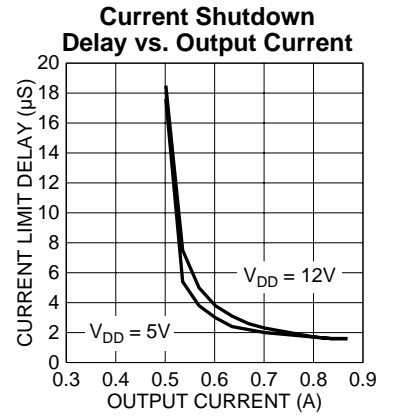
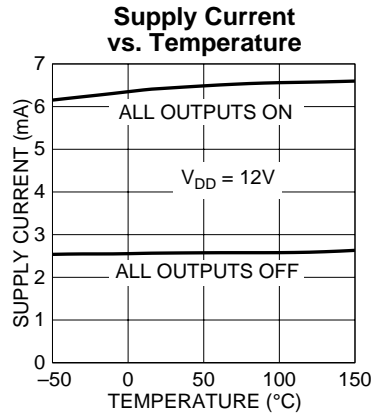
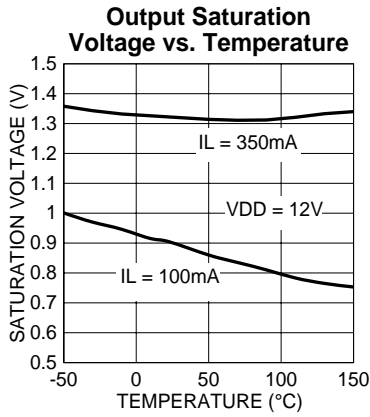
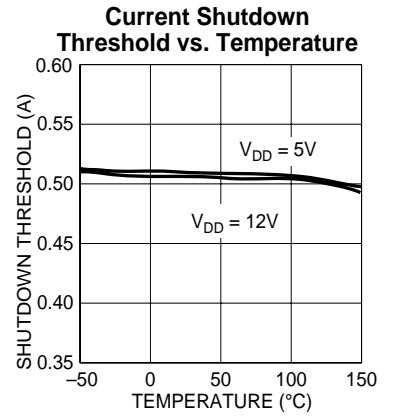
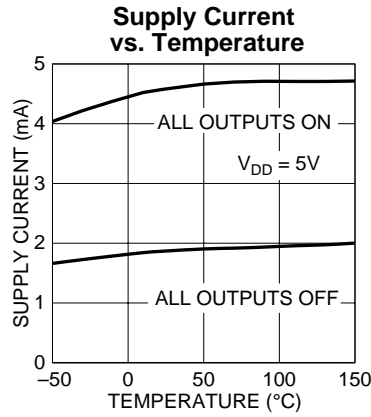
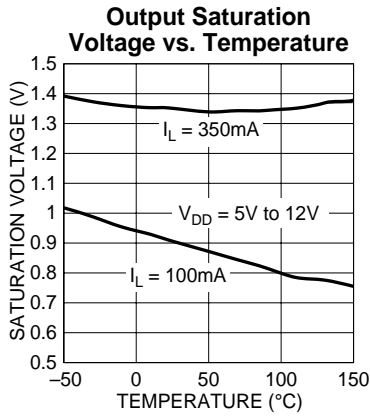

Maximum Allowable Duty Cycle (Plastic DIP)

V_{DD} = 5.0V

Number of Outputs ON (I _{OUT} = 200mA V _{DD} = 5.0V)	Max. Allowable Duty Cycle at Ambient Temperature of				
	25°C	40°C	50°C	60°C	70°C
8	85%	72%	64%	55%	46%
7	97%	82%	73%	63%	53%
6	100%	96%	85%	73%	62%
5	100%	100%	100%	88%	75%
4	100%	100%	100%	100%	93%
3	100%	100%	100%	100%	100%
2	100%	100%	100%	100%	100%
1	100%	100%	100%	100%	100%

V_{DD} = 12V

Number of Outputs ON (I _{OUT} = 200mA V _{DD} = 12V)	Max. Allowable Duty Cycle at Ambient Temperature of				
	25°C	40°C	50°C	60°C	70°C
8	80%	68%	60%	52%	44%
7	91%	77%	68%	59%	50%
6	100%	90%	79%	69%	58%
5	100%	100%	95%	82%	69%
4	100%	100%	100%	100%	86%
3	100%	100%	100%	100%	100%
2	100%	100%	100%	100%	100%
1	100%	100%	100%	100%	100%

Typical Applications

Protected Solenoid Driver with Output Enable

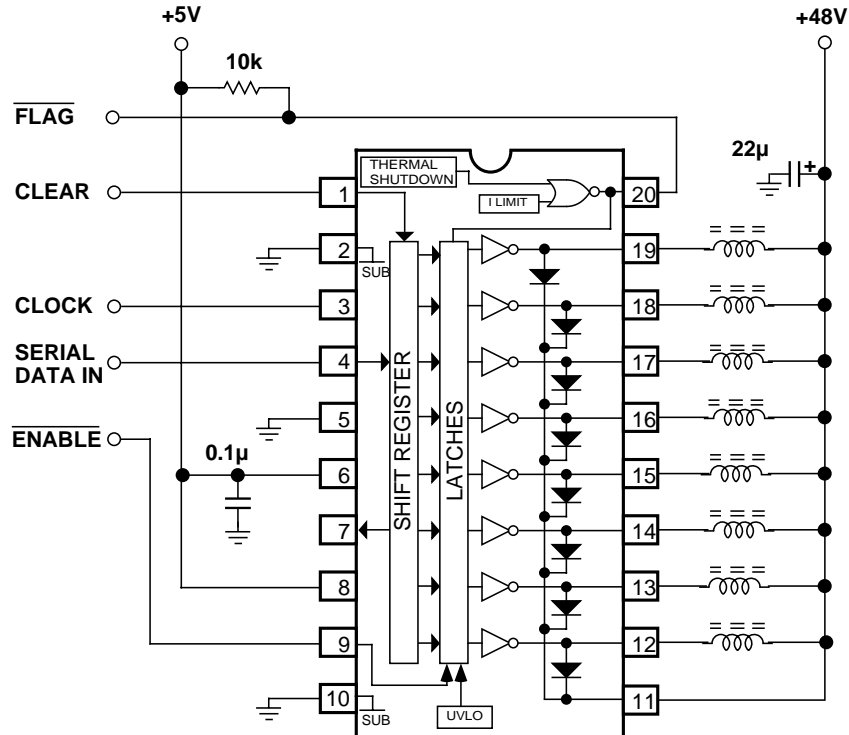

Hammer Driver

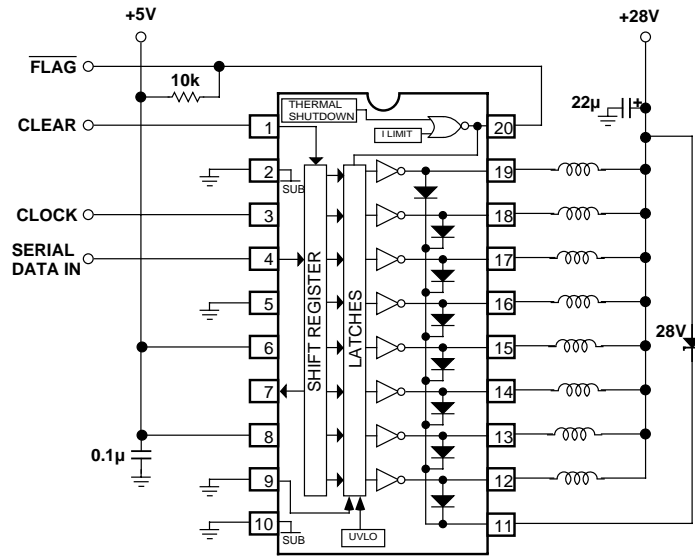

Protected Negative/Positive PIN Diode Driver Transmit/Receive Switch

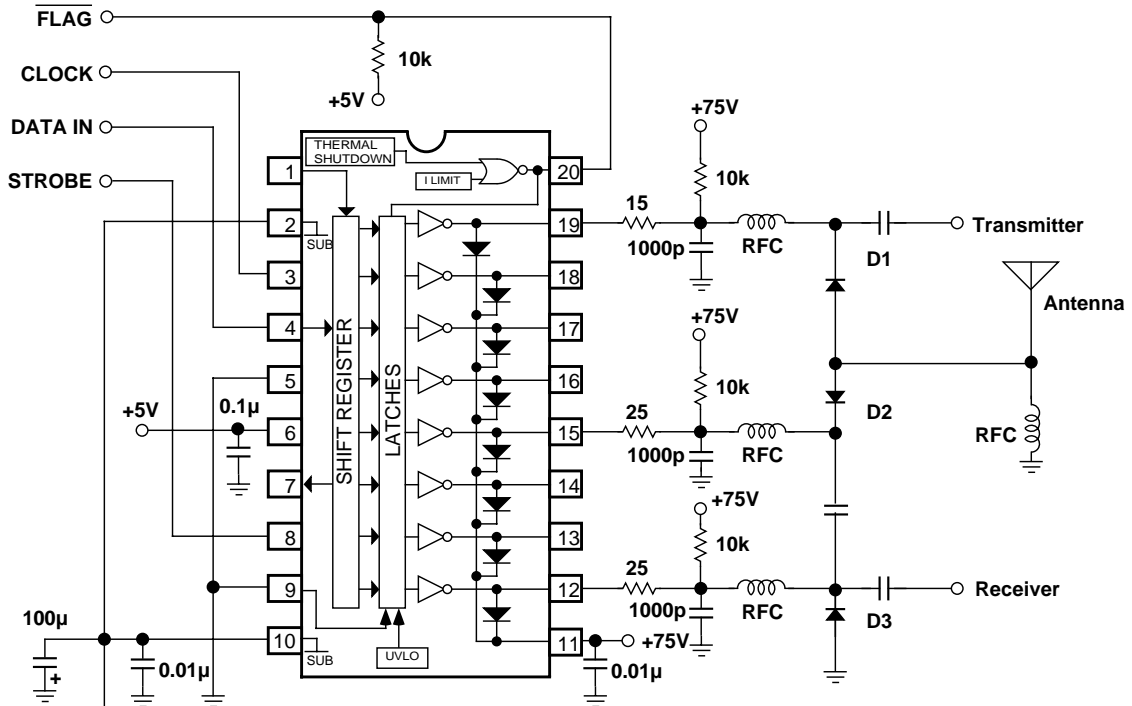

	D1 (Latch 1)	Diode D2 (Latch 5)	D3 (Latch 8)
Receive	OFF	ACTIVE	OFF
Transmit	ACTIVE	OFF	ACTIVE

PIN Diodes: UM9651

Package Information

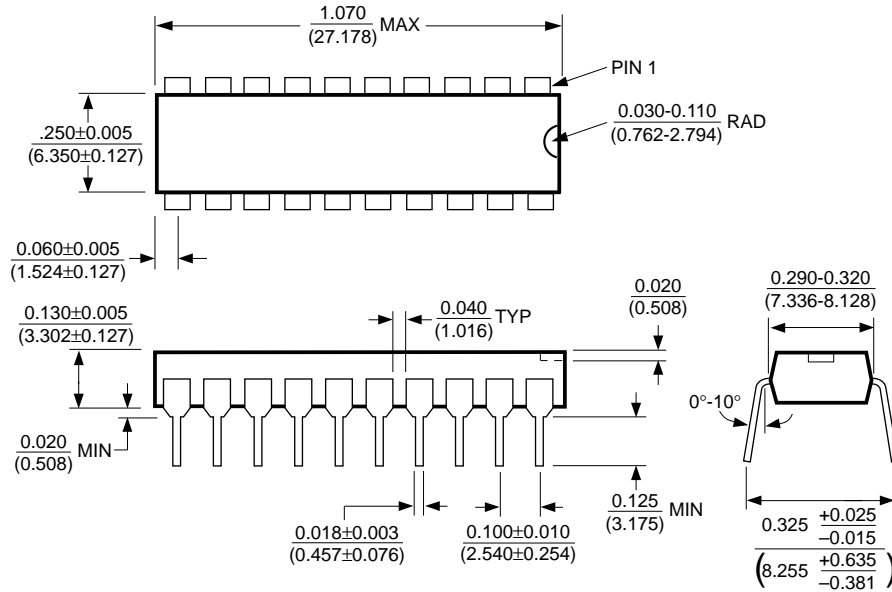

20-Pin Plastic DIP (N)

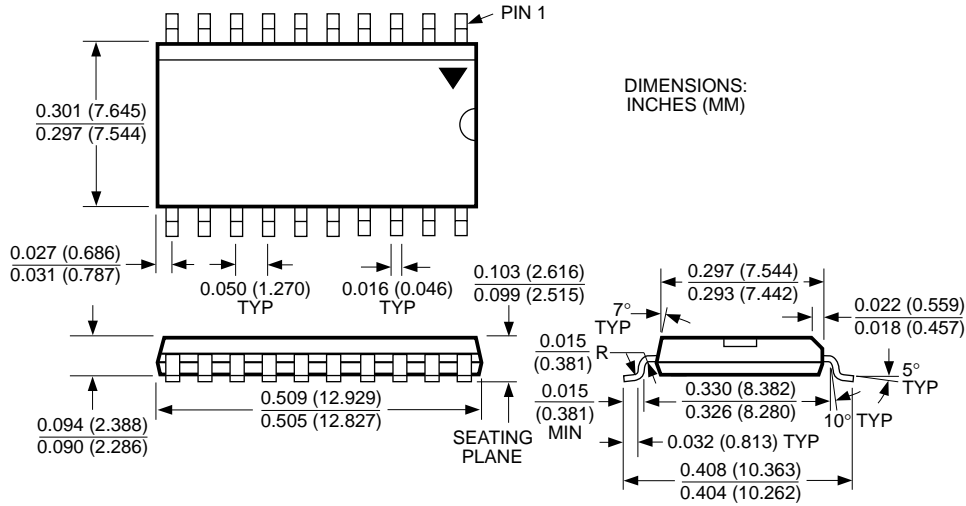

20-Pin Wide SOP (WM)

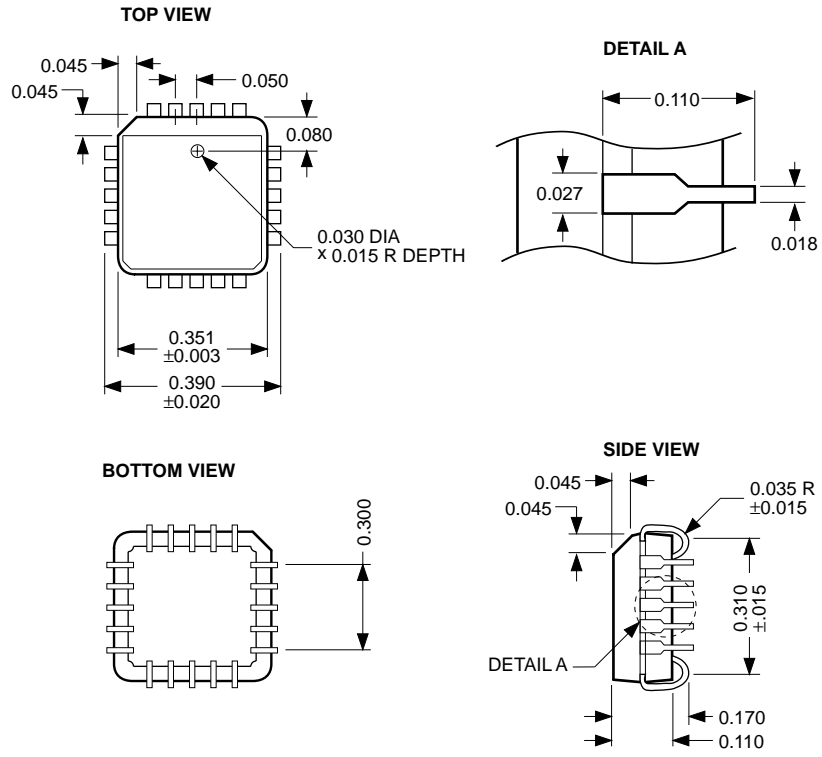

20-Pin PLCC (V)

MICREL INC. 1849 FORTUNE DRIVE SAN JOSE, CA 95131 USA

TEL + 1 (408) 944-0800 FAX + 1 (408) 944-0970 WEB <http://www.micrel.com>

This information is believed to be accurate and reliable, however no responsibility is assumed by Micrel for its use nor for any infringement of patents or other rights of third parties resulting from its use. No license is granted by implication or otherwise under any patent or patent right of Micrel Inc.

© 2001 Micrel Incorporated

Компания «Океан Электроники» предлагает заключение долгосрочных отношений при поставках импортных электронных компонентов на взаимовыгодных условиях!

Наши преимущества:

- Поставка оригинальных импортных электронных компонентов напрямую с производств Америки, Европы и Азии, а так же с крупнейших складов мира;
- Широкая линейка поставок активных и пассивных импортных электронных компонентов (более 30 млн. наименований);
- Поставка сложных, дефицитных, либо снятых с производства позиций;
- Оперативные сроки поставки под заказ (от 5 рабочих дней);
- Экспресс доставка в любую точку России;
- Помощь Конструкторского Отдела и консультации квалифицированных инженеров;
- Техническая поддержка проекта, помощь в подборе аналогов, поставка прототипов;
- Поставка электронных компонентов под контролем ВП;
- Система менеджмента качества сертифицирована по Международному стандарту ISO 9001;
- При необходимости вся продукция военного и аэрокосмического назначения проходит испытания и сертификацию в лаборатории (по согласованию с заказчиком);
- Поставка специализированных компонентов военного и аэрокосмического уровня качества (Xilinx, Altera, Analog Devices, Intersil, Interpoint, Microsemi, Actel, Aeroflex, Peregrine, VPT, Syfer, Eurofarad, Texas Instruments, MS Kennedy, Miteq, Cobham, E2V, MA-COM, Hittite, Mini-Circuits, General Dynamics и др.);

Компания «Океан Электроники» является официальным дистрибьютором и эксклюзивным представителем в России одного из крупнейших производителей разъемов военного и аэрокосмического назначения «JONHON», а так же официальным дистрибьютором и эксклюзивным представителем в России производителя высокотехнологичных и надежных решений для передачи СВЧ сигналов «FORSTAR».



JONHON

«JONHON» (основан в 1970 г.)

Разъемы специального, военного и аэрокосмического назначения:

(Применяются в военной, авиационной, аэрокосмической, морской, железнодорожной, горно- и нефтедобывающей отраслях промышленности)

«FORSTAR» (основан в 1998 г.)

ВЧ соединители, коаксиальные кабели, кабельные сборки и микроволновые компоненты:

(Применяются в телекоммуникациях гражданского и специального назначения, в средствах связи, РЛС, а так же военной, авиационной и аэрокосмической отраслях промышленности).



Телефон: 8 (812) 309-75-97 (многоканальный)

Факс: 8 (812) 320-03-32

Электронная почта: ocean@oceanchips.ru

Web: <http://oceanchips.ru/>

Адрес: 198099, г. Санкт-Петербург, ул. Калинина, д. 2, корп. 4, лит. А