

GlobalTop Technology Inc.



Titan X1

GNSS Module Datasheet (Tape-Reel)

Part Number: GMS-3302

Revision: VoA

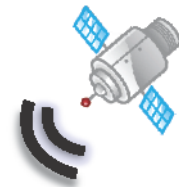

Revision history

GlobalTop Titan X1 GNSS Module Datasheet			
Revision	Date	Author	Description
V0A	2017/02/28	Dylan	Preliminary

Table of Contents

1. Function Description	4
1.1 Overview	4
1.2 Product highlights and features	5
1.3 System Block Diagram	6
1.4 Multi-tone Active Interference Canceller	6
1.5 1PPS	7
1.6 AGPS for faster TTFF (EPO in flash™)	7
1.7 EASY™	7
1.8 AlwaysLocate™	8
1.9 LOCUS	8
2.0 PPS sync NMEA	9
2.1 Antenna Advisor	9
2. Specifications	10
2.1 Mechanical Dimension	10
2.2 Recommended PCB pad Layout	11
2.3 Pin Configuration	11
2.4 Pin Assignment	12
2.5 Description of I/O Pin	13
2.6 Specification	16
2.7 Absolute Maximum Ratings	17
2.8 Operating Conditions	17
3. Protocols	18
3.1 NMEA Output Sentences	18
3.2 MTK NMEA Command Protocols	24
3.3 Antenna Status Protocol (Antenna Advisor)	25
3.4 Firmware Customization Services	25
4. Reference Design	26
4.1 The reference schematic design for using RTCM/I ² C/SPI	26
4.2 Active Antenna	29
5. Packing and Handling	30
5.1 Packaging & Handling (Tape-Reel)	30
5.2 Storage and Floor Life Guideline	32
5.3 Conditions For Pre-baking	33
5.4 Drying	34
5.5 ESD Handling	35
6. Reflow Soldering Temperature Profile	36
6.1 SMT Reflow Soldering Temperature Profile (For Reference Only)	36
6.2 Manual Soldering	40
7. Contact Information	40

1. Function Description

1.1 Overview

Titan X1 is a POT (Patch On Top) GNSS module with an extra embedded function for external antenna I/O and comes with automatic antenna switching function and also features a antenna system called "Antenna Advisor" that helps with the detections and notifications of different antenna statuses, including active antenna connection; it is one of the smallest MediaTek-based modules in the world, for it has an ultra-compact size of 12.5 x 12.5 x 6.8 mm in a QFN Package. This ultra-compact module provides multiple interfaces such as I2C, SPI & UART, and its unique design of SMPS is capable of reducing power consumption to a great extent.

Titan X1 is built based on MediaTek's new generation GNSS Chipset MT3333. It supports up to 210 PRN channels with 99 search channels and 33 simultaneous tracking channels. With support of QZSS, SBAS (WAAS, EGNOS, MSAS), QZSS and AGPS, Titan X1 can provide even more accurate positioning. Its Tone Active Interference Canceller is capable of removing 12 active noise sources and such feature enables more flexibility in system design.

Titan X1 is integrated along with power managements and many advanced features, including AlwaysLocate™, EASY™, EPO™, PPS sync NMEA and logger. It is ideally suitable for power sensitive devices especially for portable applications.

Potential Applications:

- ❖ Handheld Devices
- ❖ M2M applications
- ❖ Asset management
- ❖ Surveillance systems
- ❖ Wearable products

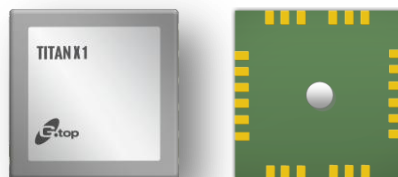

1.2 Product highlights and features

- 📍 33 tracking/ 99 acquisition-channel GPS +GLONASS receiver
- 📍 Supports QZSS & SBAS(WAAS, EGNOS, MSAS, GAGAN) ^{*1}
- 📍 Sensitivity: -165dBm
- 📍 Update Rate: up to 10Hz ^{*2}
- 📍 12 multi-tone active interference canceller
- 📍 High accuracy 1-PPS timing (± 10 ns RMS) and the pulse width is 100ms
- 📍 AGPS Support for Fast TTFF (EPO in flash™; choose from 7 days or 14 days)
- 📍 EASY™: Self-Generated Orbit Prediction for instant positioning fix ^{*3}
- 📍 AlwaysLocate™ Intelligent Algorithm (Advance Power Periodic Mode) for power saving ^{*3}
- 📍 PPS sync NMEA ^{*3}
- 📍 LOCUS (Embedded Logger Function) ^{*4}
- 📍 Gtop Firmware Customization Services
- 📍 Automatic antenna switching function
- 📍 Antenna Advisor function
- 📍 Support interface types : I2C/ SPI/ UART (configuration)
- 📍 Consumption current(@3.3V):
 - 📍 For GPS+GLONASS
 - Acquisition (min / typical / max): 23mA/ 27mA /30mA
 - Tracking(min / typical / max): 20mA / 25mA /35mA
- 📍 E911, RoHS, REACH compliant
- 📍 CE, FCC Certification
 - **FCC Report Number** : T161216N03-D
 - **Technical Standard**: FCC 47 CFR PART 15 SUBPART B and ANSI C63.4(2014) IC ICES-003
 - **CE Reference Number**: T161216N03-E
 - **Applicable Standards**: EN55032:2012+AC:2013, Class B; EN55024:2010; IEC 61000-4-2:2008; IEC 61000-4-3:2010; IEC 61000-4-8:2009

^{*1}: GAGAN will be supported upon its starting date of service.

^{*2}: SBAS can only be enabled when update rate is equal or less than to 5Hz.

^{*3}: The features need customized firmware or command programming handled by customer. Please refer to our "PMTK Command List"

^{*4}: Please refer to "GlobalTop LOCUS Library User Manual"

1.3 System Block Diagram

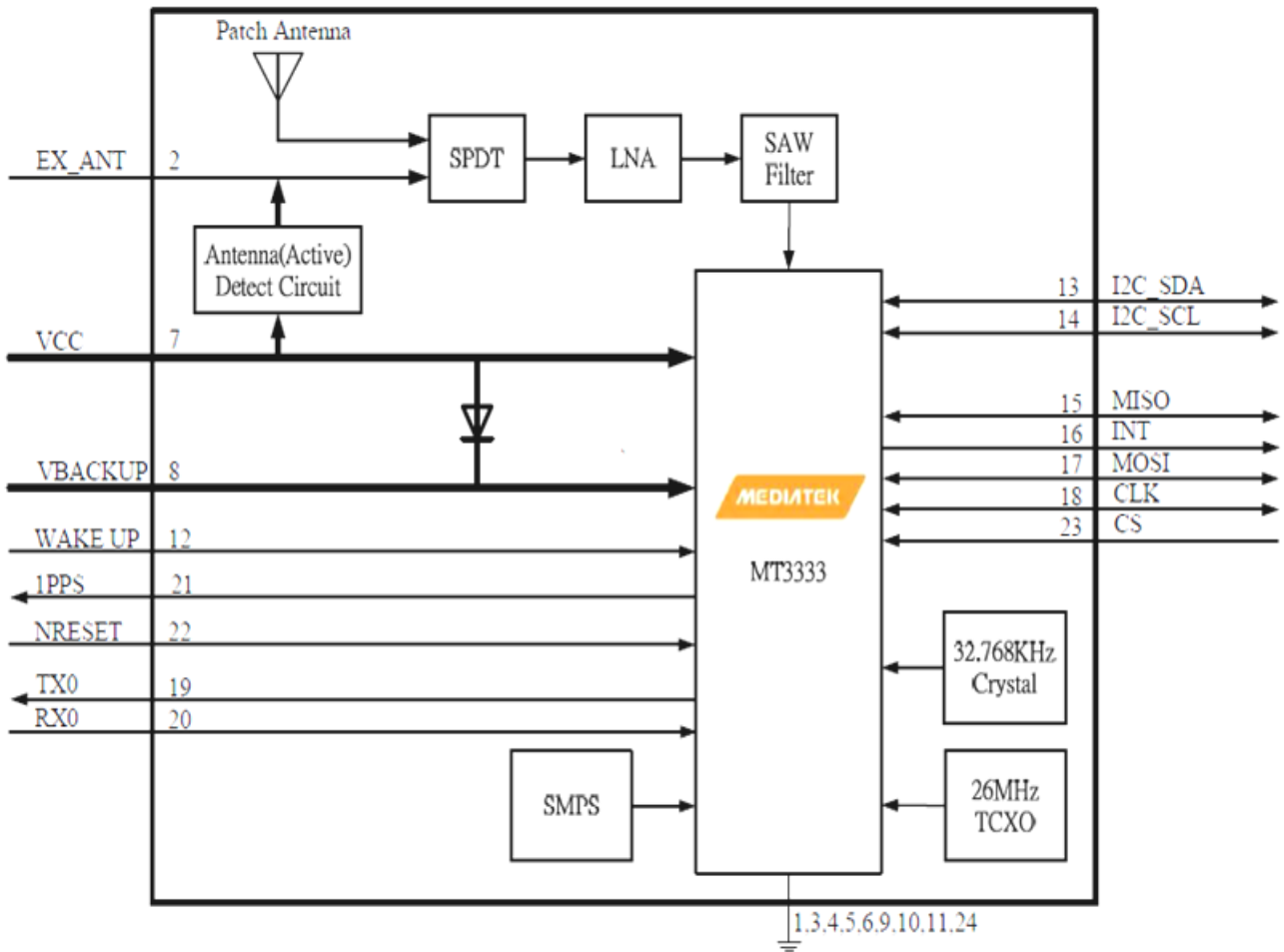

Fig. 1.1 System Block Diagram

1.4 Multi-tone Active Interference Canceller

Navigation system often integrated with variant applications that are not limited to Wi-Fi, GSM/GPRS, 3G/4G, Bluetooth. Such system, as often seen, generates RF harmonics which would influence the GPS reception and performance. The embedded Multi-tone Active Interference Canceller (MTAIC) can reject unwanted RF harmonics of the nearby on-board active components. MTAIC improves the capacity of GPS reception, leaving hardware integration engineering without the need of hardware changes. Titan X1 cancels up to 12 independent channels continuous interference wave.

1.5 1PPS

Titan X1 generates a_pulse_per_second signal (1 PPS). It is an electrical signal which precisely indicates the start of a second with the accuracy of $\pm 10\text{ns}$ RMS(Root Mean Square). The PPS signal is provided through designated output pin for many external applications. The pulse is not only limited to being active every second but also allowed to set up required duration, frequency and active high/low by programming user-defined setting.

1.6 AGPS for faster TTFF (EPO in flash™)

The AGPS (EPO in flash™) provides predicated **EPO (Extended Prediction Orbit)** data to speed up TTFF (Time To First Fix). This feature comes useful when satellite signal is weak. AGPS can be downloaded from FTP server via internet or wireless network. The GPS engine in the module will apply EPO data to assist position calculation when navigation information from satellites is insufficient. For more details on EPO, please contact us.

1.7 EASY™

EASY™ (Embedded Assist System) is for quick positioning/TTFF when information received from the satellites is insufficient (weak signal). When EASY™ is enabled, the GPS engine will automatically calculate and then predict single ephemeris up to 3 days. The predicted information will be saved onto the memory and the GPS engine will then use the saved information for later positioning. Backup power (VBACKUP) is required for EASY™.

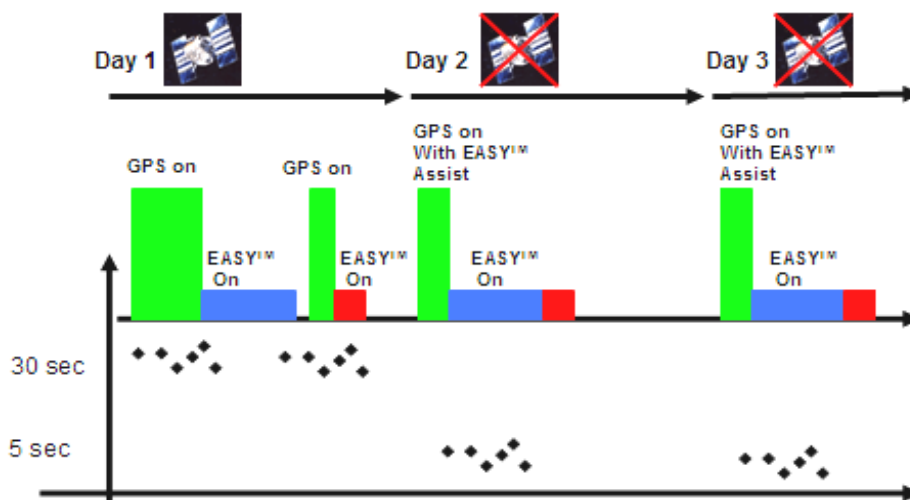

Fig. 1.2
Operation of EASY™

When the module obtains information from GPS satellites, the GPS engine will start to pre-calculate and predict orbits automatically for 3 days.

1.8 AlwaysLocate™

In AlwaysLocate™ mode, the on/off time can be adjusted adaptively to achieve balance between positioning accuracy and power consumption depending on environmental or motion conditions.

The following figure (figure 1.3) gives some insight on power saving under different cases when AlwaysLocate™ mode is enabled. For command detail, please contact our sales staff at sales@gtop-tech.com.

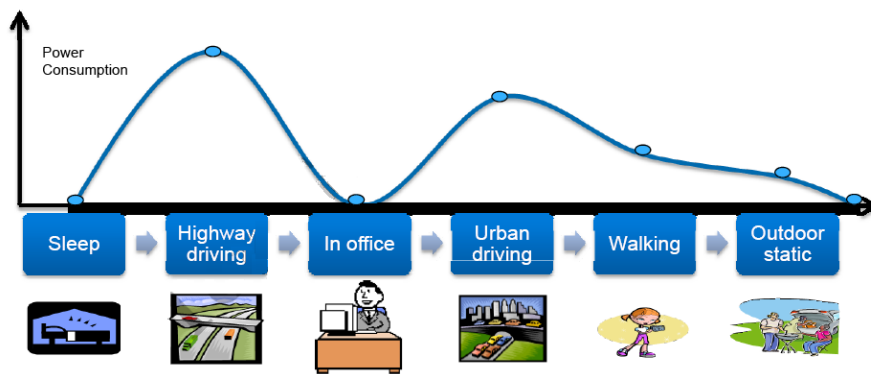

Fig. 1.3 AlwaysLocate

1.9 LOCUS

When LOCUS (Embedded Logger Function) is enabled, the receiver module will become a logger capable device. It does not need any host or external flash data format such as UTC, latitude, longitude, valid or checksum for GPS data logging. The maximum log duration is up to 2 days under AlwaysLocate™.

2.0 PPS sync NMEA

Pulse Per Second (PPS) VS. NMEA can be used in time service. The latency range of the beginning of **UART TX** is between 465 ms ~ 485 ms at MT3333 platform and behind the rising edge of PPS.

The PPS sync NMEA only supports 1Hz NMEA output and baud rate at 115200 ~ 14400. For baud rate at 9600 and 4800, only RMC NMEA sentence is supported. If NMEA sentence outputs are supported even at the low baud rate, per-second transmission may exceed the threshold of one second.

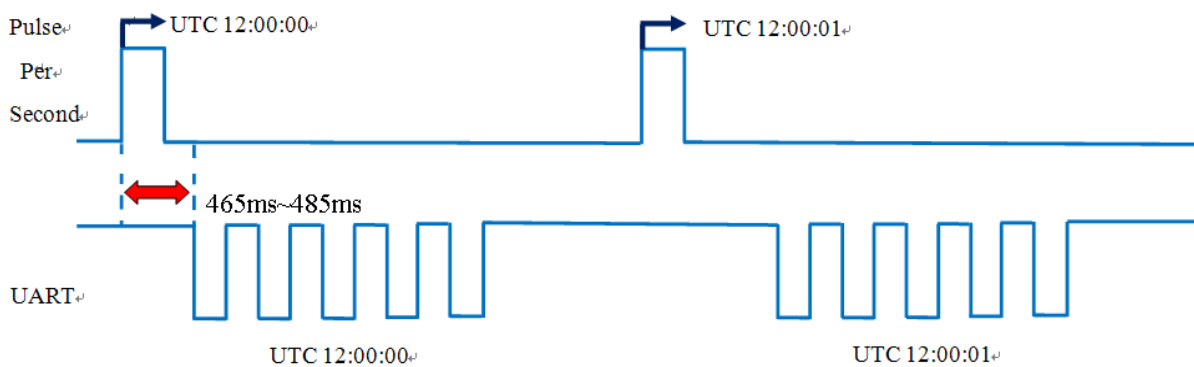

Fig. 1.4 PPS sync NMEA

2.1 Antenna Advisor

“Antenna Advisor” is a brand new antenna system available exclusively for Titan X1. It is designed to detect and notify antenna status using software (through proprietary protocol on Section 3.3).

Antenna Advisor can detect and notify the following:

- Using Internal Antenna
- Using Active Antenna

2. Specifications

2.1 Mechanical Dimension

Dimension: (Unit: mm, Tolerance: +/- 0.2mm)

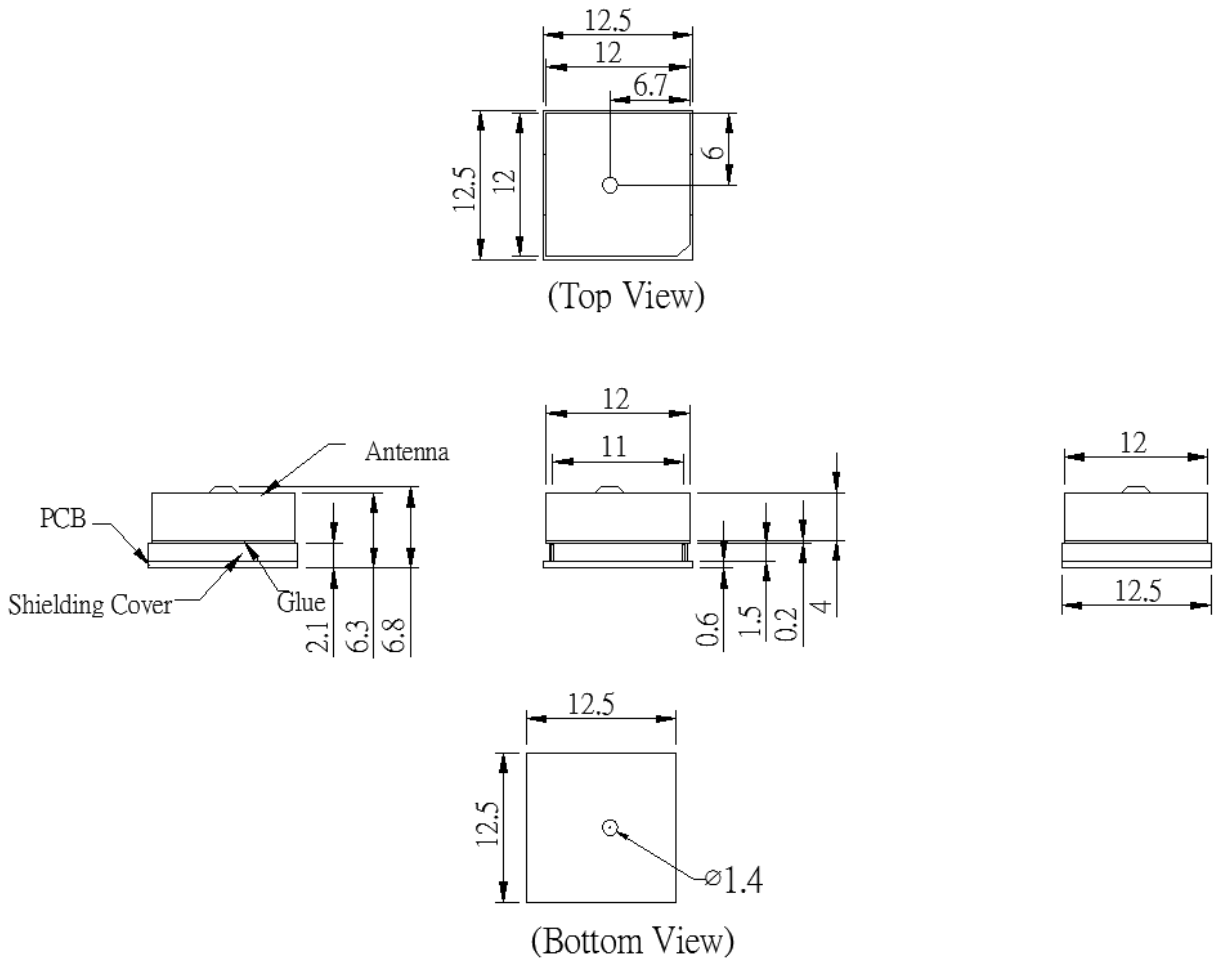

Fig. 2.1 Mechanical Dimension

2.2 Recommended PCB pad Layout

(Unit: mm, Tolerance: 0.1mm)

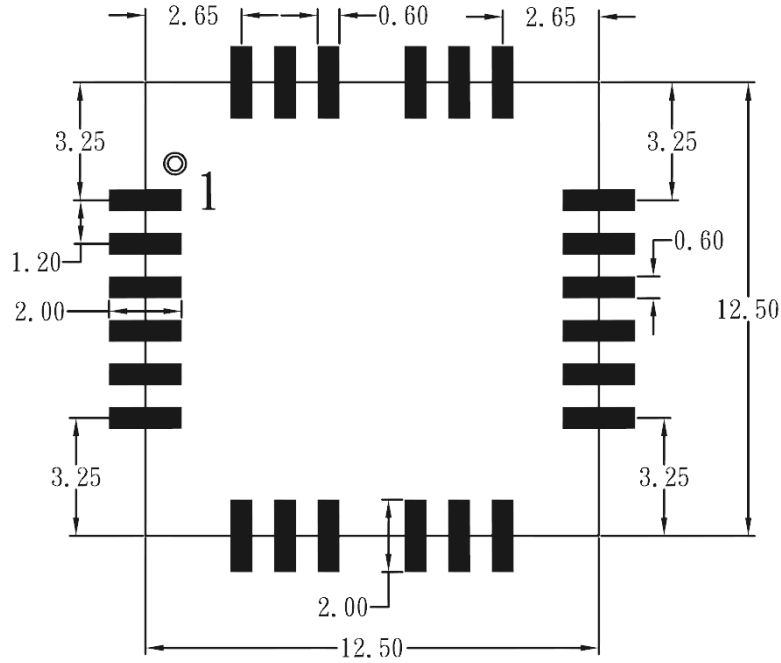

Fig. 2.2 PCB pad

2.3 Pin Configuration

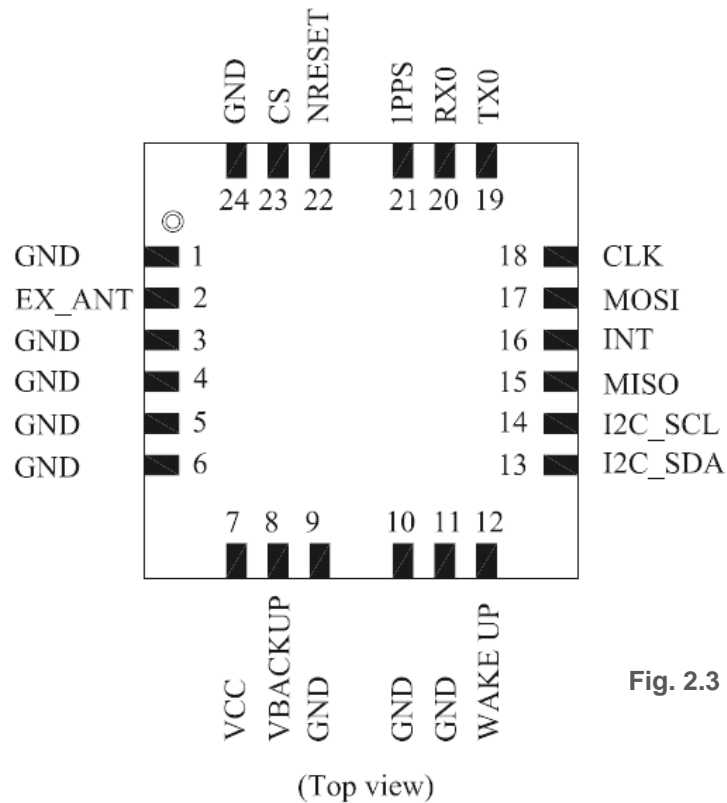

Fig. 2.3 Pin Configuration

2.4 Pin Assignment

Pin	Name	I/O	Description & Note
1	GND	P	Ground
2	EX_ANT	I PO	External active antenna RF input DC power from VCC and provide for external active antenna
3	GND	P	Ground
4	GND	P	Ground
5	GND	P	Ground
6	GND	P	Ground
7	VCC	PI	Main DC power input
8	VBACKUP	PI	Backup power input for RTC & navigation data keep
9	GND	P	Ground
10	GND	P	Ground
11	GND	P	Ground
12	WAKE UP	PI	Wake up from power saving, High Active
13	I2C_SDA	I/O	I2C Serial data(in slave mode)
14	I2C_SCL	I	I2C Serial clock(in slave mode)
15	MISO	O	SPI serial data output (in slave mode)
16	INT	O	Interrupt pin for SPI or I2C
17	MOSI	I	SPI serial data input (in slave mode)
18	CLK	I	SPI serial clock
19	TX0	O	Serial Data Output for NMEA output (TTL)
20	RX0	I	Serial Data Input for Firmware update (TTL)
21	1PPS	O	1PPS Time Mark Output 2.8V CMOS Level (Optional: pulse width can be customized)
22	NRESET	I	Reset Input, Low Active
23	CS	I	SPI serial chip select
24	GND	P	Ground

Fig. 2.4 Pin Assignment

2.5 Description of I/O Pin

Pin1: GND (Ground)

Pin2: EX_ANT

When a 4mA or higher current is detected, the detect circuit will acknowledge the external antenna as being present and will use external antenna for reception. In the event of short circuit occurring at external antenna, the module will limit the drawn current to a safe level. DC power from VCC and will be provided for external active antenna (Recommended voltage: 3.3V).

Pin3: GND (Ground)

Pin4: GND (Ground)

Pin5: GND (Ground)

Pin6: GND (Ground)

Pin7: VCC

Main DC power supply (3.0V to 4.3V; typical: 3.3V). The ripple must be controlled under 50mVpp.

Pin8: VBACKUP

This connects to the backup power of the GNSS module. Power source (such as battery) connected to this pin will help the GNSS chipset in keeping its internal RTC running when the main power source is turned off. The voltage ranges from 2.0V~4.3V (typical: 3.0V).

IF VBACKUP power is not reserved, the GNSS module will perform a lengthy cold start each time whenever it is powered on, as previous satellite information is not retained and for that it needs to be re-transmitted. If not used, keeps this pin floating.

Pin9: GND (Ground)

Pin10: GND (Ground)

Pin11: GND (Ground)

Pin12: WAKE UP

Active on High will wake up the module from backup (power-saving) mode.

Symbol	Min(V)	Typ(V)	Max(V)
Low	--	0	--
High	1.2	2.8	3.4

* The command is recommended with PMTK225 command for power saving. Please refer to our "PMTK

Pin13: I²C_SDA (I²C; for outputting GPS information)
Pin14: I²C_SCL (RTCM)

This pin can be modified through firmware customization.

If the pin is defined to I²C_SCL by firmware, it is used to receive the clock for I²C application (Default).

If the pin is defined to RTCM by firmware, it will receive data of DGPS/RTCM (TTL level).

If not used, keeps this pin floating.

Pin15: MISO (SPI; outputs GPS information)
Pin16: INT

This pin is interrupt sync. It is used to determine whether NMEA is stored in SPI/ I²C buffer.

If NMEA data is ready and stored in SPI/ I²C buffer, the pin will pull low.

After entire NMEA packet of one second was read, the pin will pull high.

Pin17: MOSI (SPI; to receive commands from system)
Pin18: CLK (SPI; to receive clock time from system)
Pin19: TX0 (UART 0 transmitter; outputs GPS information for application)
Pin20: RX0 (UART 0 receiver; to receive commands from system)

Pin21: 1PPS

This pin provides one pulse-per-second signal output.

If not used, keeps this pin floating.

Pin22: NRESET

Active on Low will allow the module to reset.

If not used, keep floating.

NRESET Level	Min(V)	Typ(V)	Max(V)
Low	0	0	1.5
High	2	2.8	3.3

Pin23: CS (SPI; to select chip for system)

Active on Low to enable SPI.

Pin24: GND (Ground)

2.6 Specification

Description	
GNSS Solution	MTK MT3333
Frequency	GPS L1, 1575.42MHz GLONASS L1, 1598.0625~1605.375MHz
Sensitivity (GPS portion)	Acquisition: -148dBm, cold start Reacquisition: -163dBm, Hot start Tracking: -165dBm
SV Number GPS GLONASS	#1~32 #65~96 (see 3. Protocols for details)
TTF (GPS, No. of SVs>4, C/N>40dB, PDop<1.5)	Hot start: 1 second typical Warm start: 33 seconds typical Cold start: 35 seconds typical, 60 seconds Max
Position Accuracy	Without aid:3m (50% CEP) DGPS(SBAS(WAAS,EGNOS,MSAS, GAGAN*)):2.5m (50% CEP) RTCM:3m(50% CEP)
Velocity Accuracy	Without aid : 0.1m/s DGPS(SBAS(WAAS,EGNOS,MSAS, GAGAN*)):0.05m/s
Timing Accuracy (1PPS Output)	Default: ±10ns RMS within 100ms in one pulse (pulse width/duration can be customized)
Altitude	10,000m maximum (Normal mode: car/pedestrian/ aviation) 80,000m maximum (Balloon mode)
Velocity	Maximum 515m/s (1000 knots)**
Acceleration	Maximum 4G
Update Rate	1Hz (default), maximum 10Hz
Baud Rate	9600 bps (default)
DGPS	SBAS(default) [WAAS, EGNOS, MSAS, GAGAN*]
Power Supply	VCC: 3V to 4.3V; VBACKUP: 2.0V to 4.3V
Current Consumption @ 3.3V,1Hz Update Rate	GPS+GLONASS Acquisition : 23mA(min)/ 27mA(typical) /30mA(max) Tracking: 20mA(min)/ 25mA(typical) /35mA(max)

Backup Power Consumption@ 3V	15uA (TYP)
Power Saving (Periodic)	Backup mode: 1.2mA(TYP) *** Standby mode: 1.5mA(TYP) ***
NRESET Current @ 3.3V	8mA(TYP)
Working Temperature	-40 °C to +85 °C
Dimension	12.5 x 12.5 x 6.8 mm, SMD
Weight	4g

* GAGAN will be supported

** The number was simulated from lab test

*** Please refer to PMTK 161 / 225

2.7 Absolute Maximum Ratings

The maximum power supply voltage is 4.3

	Symbol	Min.	Typ.	Max.	Unit
Power Supply Voltage	VCC	3.0	3.3	4.3	V
Backup battery Voltage	VBACKUP	2.0	3.0	4.3	V

2.8 Operating Conditions

	Condition	Min.	Typ.	Max.	Unit
Operation supply Ripple Voltage	—	—	—	50	mVpp
RX0 TTL H Level	—	2.0	—	3.3	V
RX0 TTL L Level	—	0	—	0.8	V
TX0 TTL H Level	—	2.4	—	2.8	V
TX0 TTL L Level	—	0	—	0.4	V

3. Protocols

3.1 NMEA Output Sentences

Table 1 lists all NMEA output sentences specifically developed and defined by MTK for MTK's products

Table 1: Position Fix Indicator	
Option	Description
GGA	Time, position and fix type data.
GSA	GNSS receiver operating mode, active satellites used in the position solution and DOP values.
GSV	The number of GPS satellites in view satellite ID numbers, elevation, azimuth, and SNR values.
RMC	Time, date, position, course and speed data. The recommended minimum navigation information.
VTG	Course and speed information relative to the ground.

Table 2 lists NMEA output sentences used in GPS system and GLONASS system

Table 2: NMEA Output Sentence for GPS and GNSS					
System	GGA	GSA	GSV	RMC	VTG
GPS	GPGGA	GPGSA	GPGSV	GPRMC	GPVTG
GNSS (GPS+GLONASS)	GNGGA	GPGSA GLGSA	GPGSV GLGSV*	GNRMC	GNVTG

* In Talker ID, GP is a short term of "GPS"; GL is "GLONASS" and GN is "GPS +GLONASS"

GGA—Time, Position and related data of Navigation Fix

Table 3 explains an example of NMEA sentence below:

*\$GNGGA, 064951.000, 2307.1256, N, 12016.4438, E, 1, 8, 0.95, 39.9, M, 17.8, M, *65*

Table 3: GGA Data Format			
Name	Example	Units	Description
Message ID	\$GNGGA		GGA protocol header
UTC Time	064951.000		hhmmss.sss
Latitude	2307.1256		ddmm.mmmm
N/S Indicator	N		N→North or S→South
Longitude	12016.4438		dddmm.mmmm
E/W Indicator	E		E→East or W→West
Position Fix Indicator	1		See Table-4
Satellites Used	8		
HDOP	0.95		Horizontal Dilution of Precision
MSL Altitude	39.9	meters	Antenna Altitude above/below mean-sea-level
Units	M	meters	Units of antenna altitude
Geoidal Separation	17.8	meters	
Units	M	meters	Units of geoids separation
Age of Diff. Corr.		second	Null fields when DGPS is not used
Checksum	*65		
<CR> <LF>			End of message termination

Table 4: Position Fix Indicator

Value	Description
0	Fix not available
1	GPS fix
2	Differential GPS fix

Note: when inputting the command *\$PMTK353,0,1,0,0,0*2A*,
\$GNGGA will change to *\$GLGGA* (For GLONASS)

When inputting the command *\$PMTK353,1,0,0,0,0*2A*,
\$GNGGA will change to *\$GPGGA* (For GPS)

GSA—GNSS DOP and Active Satellites, includes GPS(GPGSA) and GLONASS(GLGSA)

Table 5 explains an example of NMEA sentence below:

GPS satellite system → \$GPGSA,A,3,29,21,26,15,18,09,06,10,,,,,2.32,0.95,2.11*00

GPS+GLONASS satellite system → \$GPGSA,A,3,08,28,20,04,32,17,11,,,,,1.00,0.63,0.77*1B (GPS satellite)
 \$GLGSA,A,3,77,76,86,78,65,88,87,71,72,,,,,1.00,0.63,0.77*17 (GLONASS satellite)

Table 5: GGA Data Format			
Name	Example	Units	Description
Message ID	\$GPGSA, or \$GLGSA		GSA protocol header
Mode 1	A		See Table 6
Mode 2	3		See Table 7
Satellite Used *	08		SV on Channel 1
Satellite Used	28		SV on Channel 2
....
Satellite Used			SV on Channel 12
PDOP	1.00		Position Dilution of Precision
HDOP	0.63		Horizontal Dilution of Precision
VDOP	0.77		Vertical Dilution of Precision
Checksum	*1B		
<CR> <LF>			End of message termination

* GPS SV No. #01~#32
 GLONASS SV No. #65~#96

Table 6: mode 1	
Value	Description
M	Manual—forced to operate in 2D or 3D mode
A	2D Automatic—allowing to switch to 2D/3D mode automatically

Table 7: mode 2	
Value	Description
1	Fix not available
2	2D (< 4 SVs used)
3	3D (≥ 4 SVs used)

GSV— Satellites in View, including GPS(GPGSV) and GLONASS(GLGSV)

Table 8 explains an example of NMEA sentences below:

```
$GPGSV,4,1,14,28,75,321,44,42,54,137,39,20,53,080,44,17,40,330,44*77
$GPGSV,4,2,14,04,33,253,43,32,28,055,41,08,26,212,40,11,14,055,33*7F
$GPGSV,4,3,14,10,12,198,,07,06,179,38,23,04,125,44,27,02,314,*7E
$GPGSV,4,4,14,193,,,42,01,,,36*45
```

Table-8: GPGSV Data Format

Name	Example	Units	Description
Message ID	\$GPGSV		GSV protocol header
Number of Messages	4		<i>(Depending on the number of satellites tracked, multiple messages of GSV data may be required.) *</i>
Message Number	1		
Satellites in View	14		
Satellite ID	28		Channel 1 (Range 1 to 32)
Elevation	75	degrees	Channel 1 (Maximum 90)
Azimuth	321	degrees	Channel 1 (True, Range 0 to 359)
SNR (C/No)	44	dB-Hz	Range 0 to 99, (null when not tracking)
....
Satellite ID	17		Channel 4 (Range 1 to 32)
Elevation	40	degrees	Channel 4 (Maximum 90)
Azimuth	330	degrees	Channel 4 (True, Range 0 to 359)
SNR (C/No)	44	dB-Hz	Range 0 to 99, (null when not tracking)
Checksum	*77		
<CR> <LF>			End of message termination

* One GSV sentence can only receive up to 4 SVs

Table 9 explains an example of NMEA sentences below:

*\$GLGSV,4,1,15,72,45,084,40,77,39,246,44,87,36,014,44,65,33,157,36*62*

*\$GLGSV,4,2,15,78,26,306,41,88,23,315,42,76,15,192,38,86,13,067,38*64*

*\$GLGSV,4,3,15,71,12,035,38*54*

Table 9: GLGSV Data Format

Name	Example	Units	Description
Message ID	\$GLGSV		GSV protocol header
Number of Messages	4		<i>(Depending on the number of satellites tracked, multiple messages of GSV data may be required.)*</i>
Message Number	1		
Satellites in View	15		
Satellite ID	72		Channel 1 (Range 1 to 32)
Elevation	45	degrees	Channel 1 (Maximum 90)
Azimuth	084	degrees	Channel 1 (True, Range 0 to 359)
SNR (C/No)	40	dB-Hz	Range 0 to 99, (null when not tracking)
....
Satellite ID	44		Channel 4 (Range 1 to 32)
Elevation	65	degrees	Channel 4 (Maximum 90)
Azimuth	157	degrees	Channel 4 (True, Range 0 to 359)
SNR (C/No)	36	dB-Hz	Range 0 to 99, (null when not tracking)
Checksum	*62		
<CR> <LF>			End of message termination

* One GSV sentence can only receive up to 4 SVs

RMC—Recommended Minimum Navigation Information

Table 10 explains an example of NMEA sentence below:

*\$GNRMC,064951.000,A,2307.1256,N,12016.4438,E,0.03,165.48,260406,3.05,W,A*2C*

Table 10: RMC Data Format

Name	Example	Units	Description
Message ID	\$GNRMC		RMC protocol header
UTC Time	064951.000		hhmmss.sss
Status	A		A→data valid or V→data not valid
Latitude	2307.1256		ddmm.mmmm
N/S Indicator	N		N→North or S→South
Longitude	12016.4438		dddmm.mmmm
E/W Indicator	E		E→East or W→West
Speed over Ground	0.03	Knots/hr	
Course over Ground	165.48	degrees	True
Date	260406		ddmmyy
Magnetic Variation	3.05, W	degrees	E→East or W→West (By Customization)
Mode	A		A→ Autonomous mode D→Differential mode E→Estimated mode
Checksum	*2C		
<CR> <LF>			End of message termination
Message ID	\$GNRMC		RMC protocol header

Note: when inputting the commend *\$PMTK353,0,1,0,0,0*2A* , *\$GNRMC* will change to *\$GLRMC* (for GLONASS).

When inputting the commend *\$PMTK353,1,0,0,0,0*2A* : *\$GNRMC* will change to *\$GPRMC* (for GPS).

VTG—Course and speed information relating to the ground

Table 11 explains an example of NMEA sentence below:

```
$GNVTG,165.48,T,,M,0.03,N,0.06,K,A*37
```

Table 11: VTG Data Format

Name	Example	Units	Description
Message ID	\$GNVTG		VTG protocol header
Course	165.48	degrees	Measured heading
Reference	T		True
Course		degrees	Measured heading
Reference	M		Magnetic Variation (By Customization)
Speed	0.03	Knots/hr	Measured horizontal speed
Units	N		Knots
Speed	0.06	km/hr	Measured horizontal speed
Units	K		Kilometers per hour
Mode	A		A→ Autonomous mode D→ Differential mode E→ Estimated mode
Checksum	*37		
<CR> <LF>			End of message termination

Note: When inputting the command \$PMTK353,0,1,0,0,0*2A , \$GNVTG will change to \$GLVTG(For GLONASS)

When inputting the command \$PMTK353,1,0,0,0,0*2A : \$GNVTG will change to \$GPVTG (For GPS)

3.2 MTK NMEA Command Protocols

Packet Type: 103 PMTK_CMD_COLD_START

Packet Meaning: Cold Start --- Discarding the data of *Time, Position, Almanacs* and *Ephemeris* at re-start.

Example: \$PMTK103*30<CR><LF>

3.3 Antenna Status Protocol (Antenna Advisor)

Packet Type: Status of antenna

Table 12: PGCMD Data Format

Name	Example	Units	Description
Message ID	\$ PGCMD		Protocol header
Command ID	203		Function Type

Example: \$PGCMD,203<CR><LF>

Used **Patch antenna** status : PGACK,GTOP Antenna **Internal**.

Used **Active antenna** status : PGACK,GTOP Antenna **External**.

3.4 Firmware Customization Services

GlobalTop also offers flexible and value-adding GPS firmware customization service to maximize overall system efficiencies and power consumptions for customers' products. For more of our latest features such as Binary Mode, One-Sentence Output, Geo-fencing and Last Position Retention etc., please contact at

sales@gtop-tech.com

GlobalTop Firmware Customization Services

Basic functions:

- 10Hz Update Rate
- Extended Altitude
- AGPS
- PPS Mode
- Power Saving Mode
- Locus

Advanced functions:

- Distance calculation
- Binary mode
- One sentence
- Geo-fencing
- Navigation mode
- Last position retention

Note: Not all firmware customization services listed are supported for all products.

Please contact GlobalTop sales representative or technical support for more detail.

4. Reference Design

4.1 The reference schematic design for using RTCM/I²C/SPI

The Titan X1 provides several interfaces to process GNSS NMEA data (by specified firmware):

- (1) **UART0 + RTCM** (for DGPS data)
- (2) **UART0 + I²C** (for NMEA data)
- (3) **UART0 + SPI** (for NMEA data)

A. schematic reference design for RTCM:

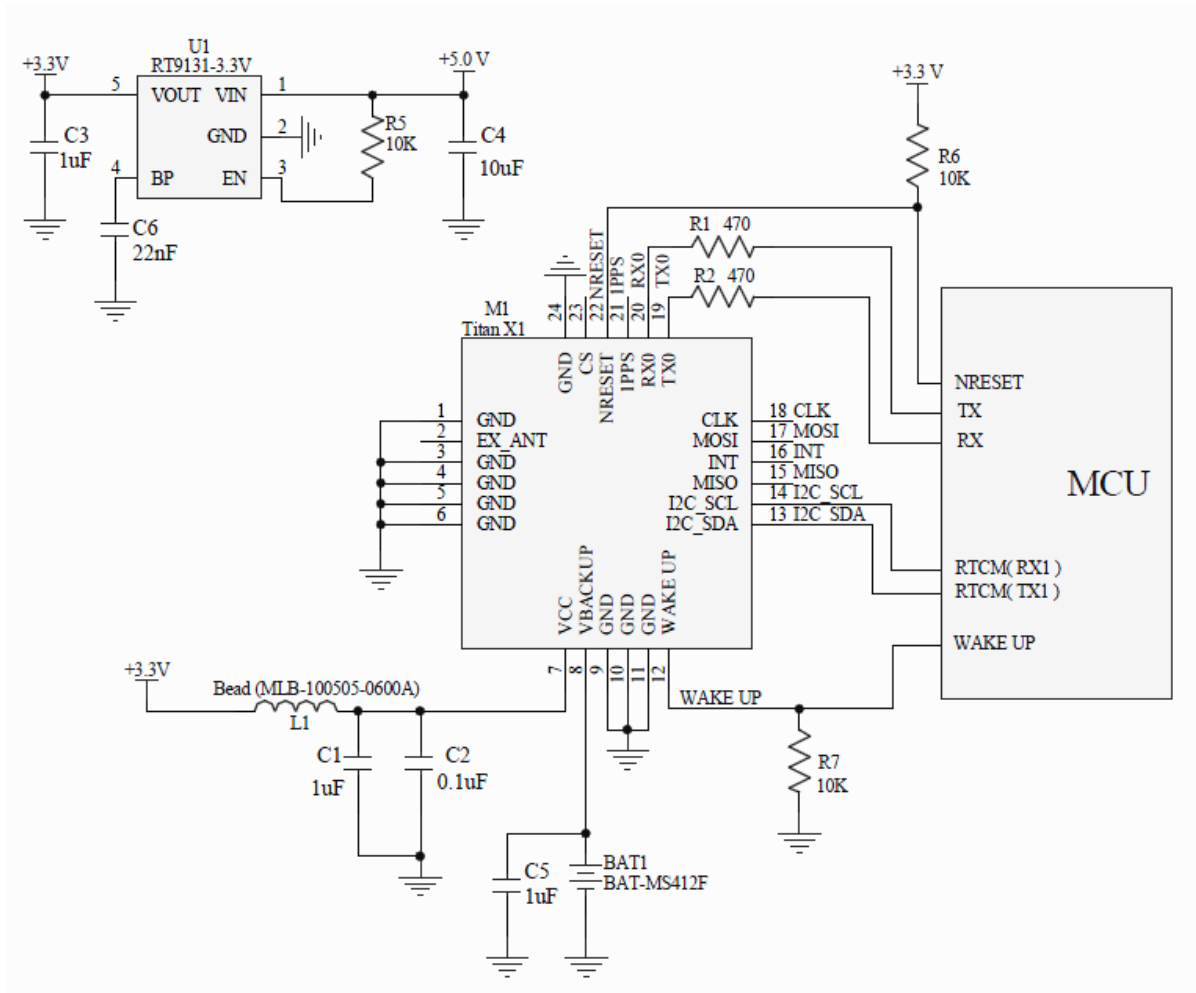

Fig. 4.1 UART + RTCM

Note:

1. Ferrite bead L1 is added for power noise reduction. Use one with equivalent impedance (600Ω at 100MHz; IDC 200mA).

2. Place C1, C2 and C5 bypass-capacitors as close as possible to the module.
3. Damping resistors R1 and R2 can be modified to manage EMI for system application.
4. The default of Pull-low resistor R7 is set at low level for WAKE UP pin to function.
5. If you need more support and information on antenna implementation, please contact us at sales@gtop-tech.com.

B. schematic reference design for using I²C

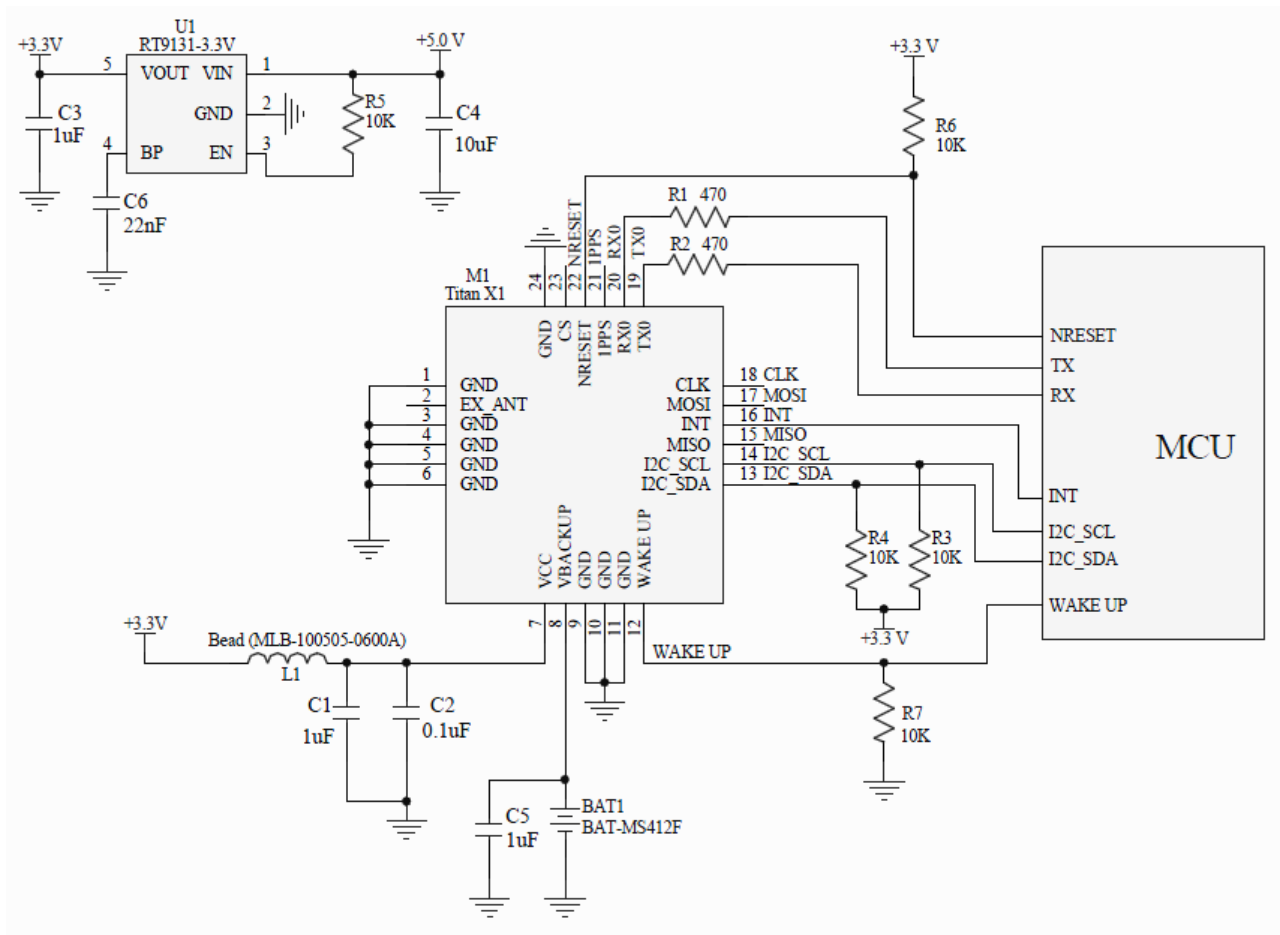

Fig. 4.2 UART + I²C

Note:

1. Ferrite bead L1 is added for power noise reduction. Use one with equivalent impedance (600Ω at 100MHz; IDC 200mA).
2. Place C1, C2 and C5 bypass-capacitors as close as possible to the module.
3. Damping resistors R1 and R2 can be modified to manage EMI for system application.
4. Pull high resistors, R3 and R4, can be modified based on system application for I²C.
5. The default of Pull-low resistor R7 is set at low level for WAKE UP pin to function.
6. If you need more support and information on antenna implementation, please contact us at sales@gtop-tech.com.

C. schematic reference design for SPI bus

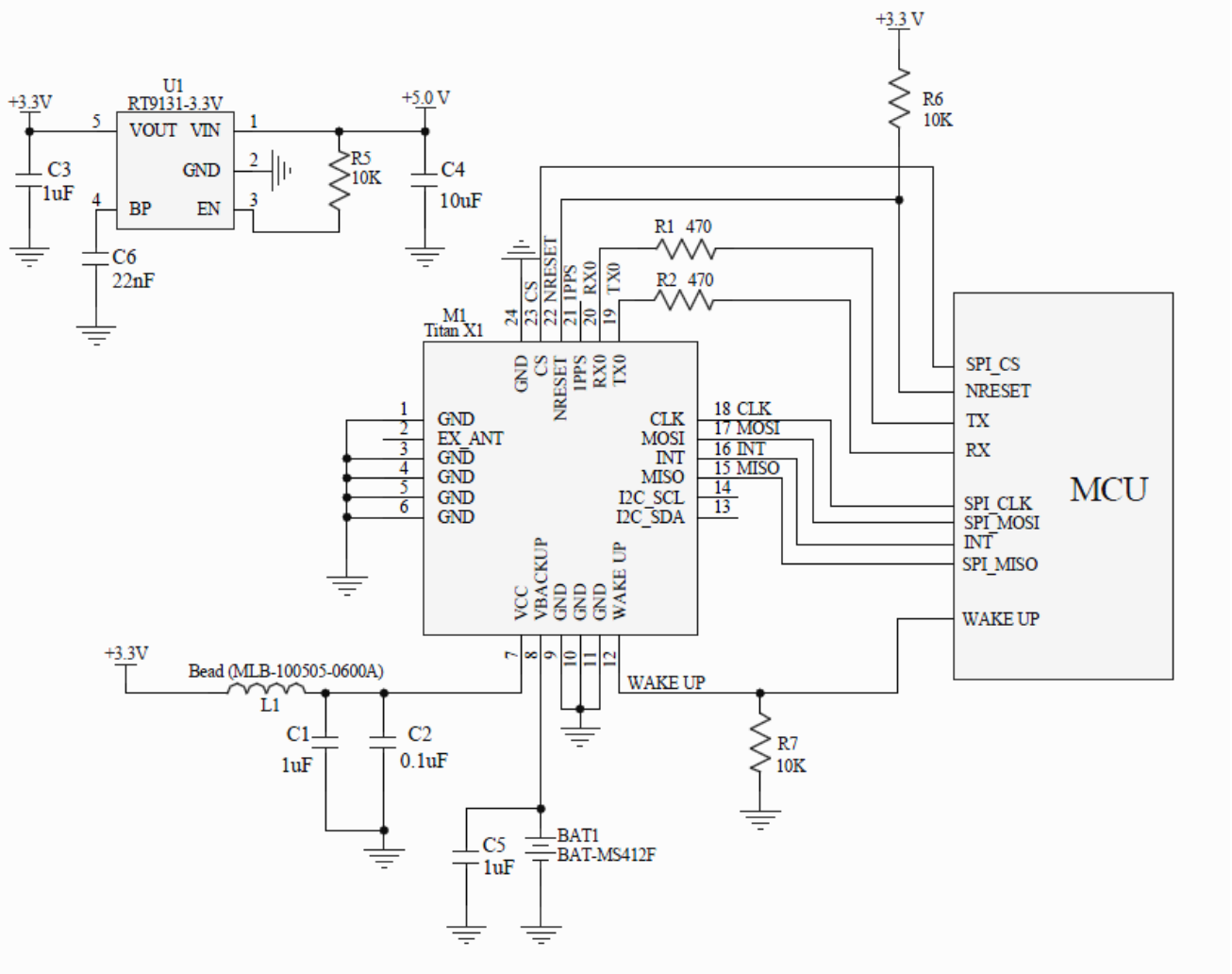

Fig. 4.3 UART+SPI application

Note:

1. Ferrite bead L1 is added for power noise reduction. Use one with equivalent impedance (600Ω at 100MHz; IDC 200mA).
2. Place C1, C2 and C5 bypass-capacitors as close as possible to the module.
3. Damping resistors R1 and R2 can be modified to manage EMI for system application.
4. The default of Pull-low resistor R7 is set at low level for WAKE UP pin to function.
5. If you need more support and information on antenna implementation, please contact us at sales@gtop-tech.com.

4.2 Active Antenna

Please connect the external antenna to EX_ANT (Pin2)

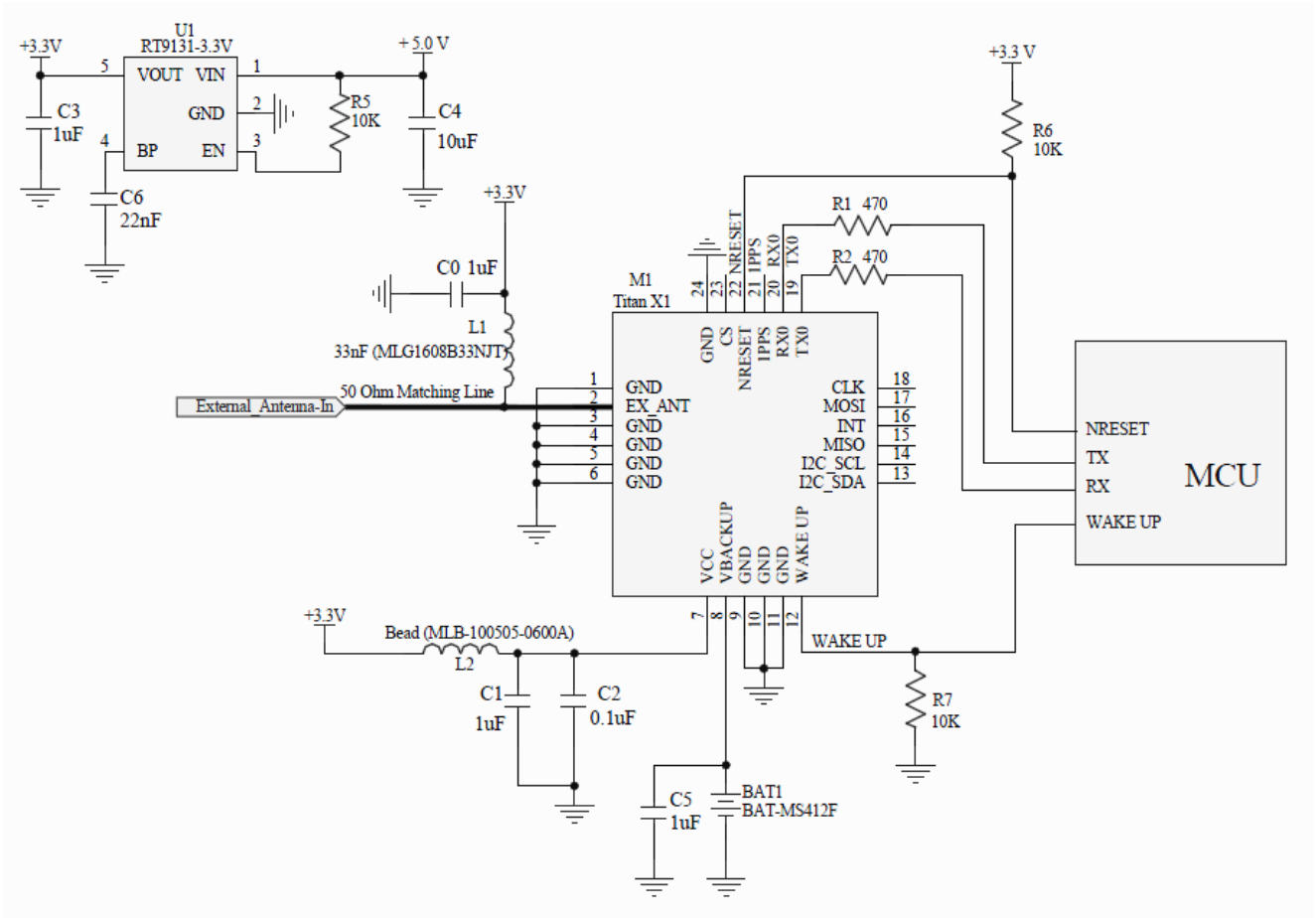

Fig. 4.4 Active Antenna application

Note:

1. Ferrite bead L1 is added for power noise reduction. Use one with equivalent impedance (600Ω at 100MHz; IDC 200mA).
2. Place C1, C2 and C5 bypass-capacitors as close as possible to the module.
3. Damping resistors R1 and R2 can be modified to manage EMI for system application.
4. The default of Pull-low resistor R7 is set at low level for WAKE UP pin to function.
5. If you need more support and information on antenna implementation, please contact us at sales@gtop-tech.com.

5. Packing and Handling

Titan X1, like any other SMD devices, is sensitive to moisture, electrostatic discharge and temperature. By following the standards of storage and handling outlined in this document for GlobalTop's modules, the chances of them being damaged during production setup can be reduced. This section will walk you through the basics on how GlobalTop packages the modules, to ensure that the modules arrive at their destination without any damages or deterioration for performance quality. Cautionary steps prior to the surface mount process are also included in the cautionary notes.

- ⚠ Please read the following sections carefully to avoid possible damages**
- ⚠ GPS/GNSS receiver modules are highly electrostatic-sensitive devices. Without ESD protections or without proper handling may lead to permanent damage to the modules.**

5.1 Packaging & Handling (Tape-Reel)

350 pcs/Reel

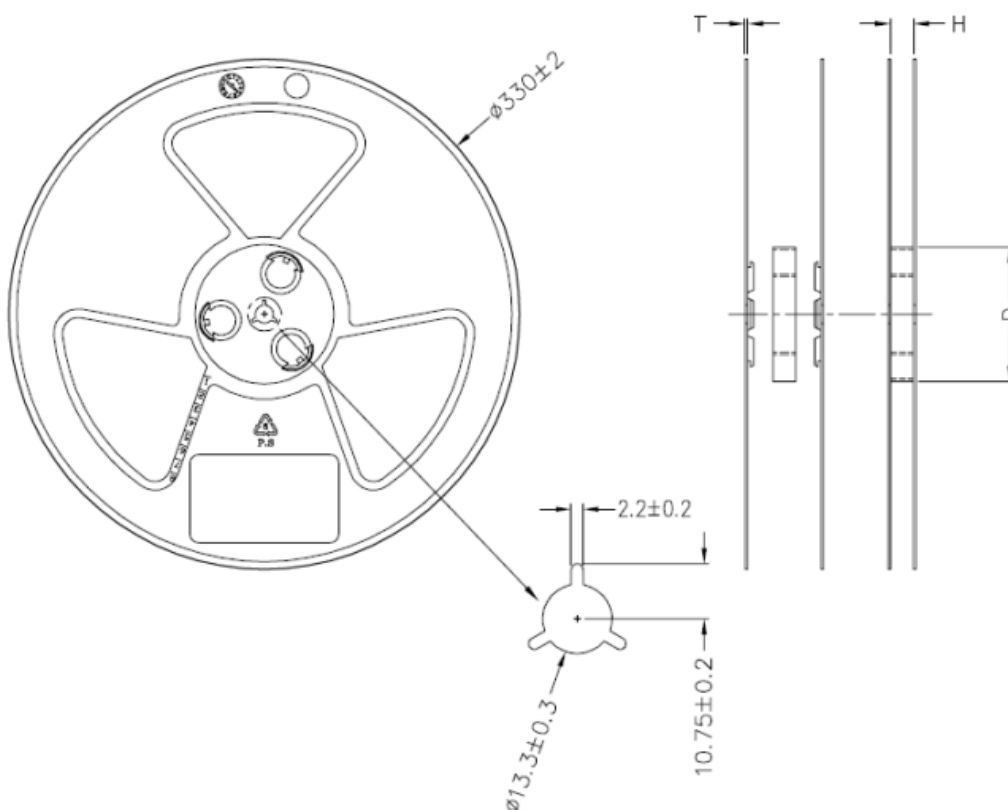

Spec:

H: 24.5 ± 1.5 ,

T: 2.2 ± 0.2 ,

D: 99 ± 1.5

Note: 13" Reel;

Material: P.S

Unit: (mm)

Fig. 5.1 Reel Dimension

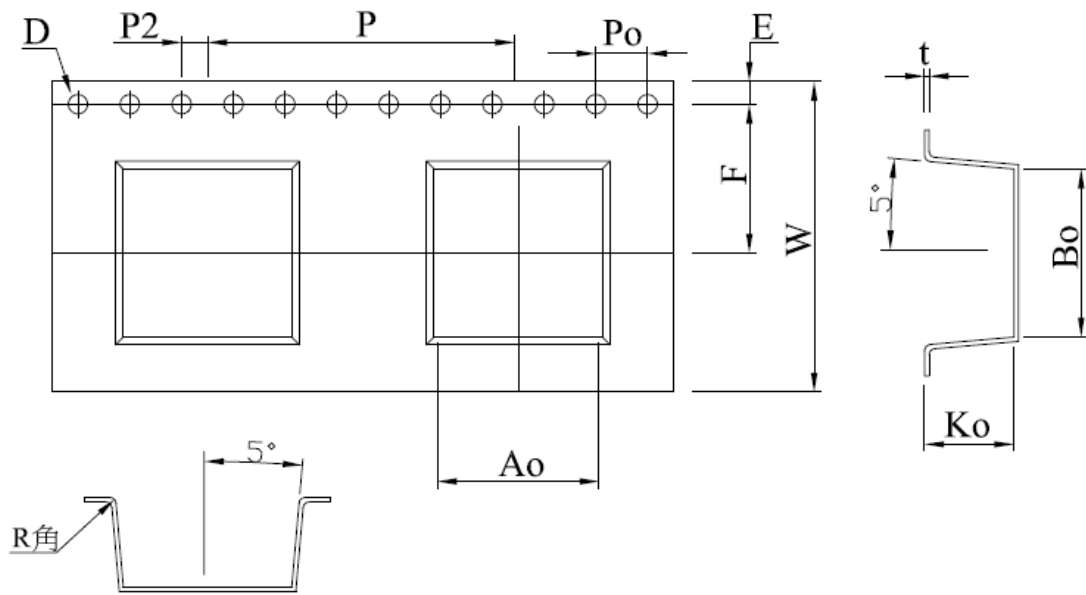

Fig. 5.2 Tape Dimension

Ao	13.0±0.10
Bo	13.0±0.10
Ko	6.90±0.10

Unit: (mm)

5.2 Storage and Floor Life Guideline

Moisture color coded card & Caution label

The moisture color coded card provides an insight to the relative humidity in percentage (RH). When the GNSS modules are taken out, the RH level for the modules would be around or lower than 30%. A caution label is also included with each electrostatic bag.

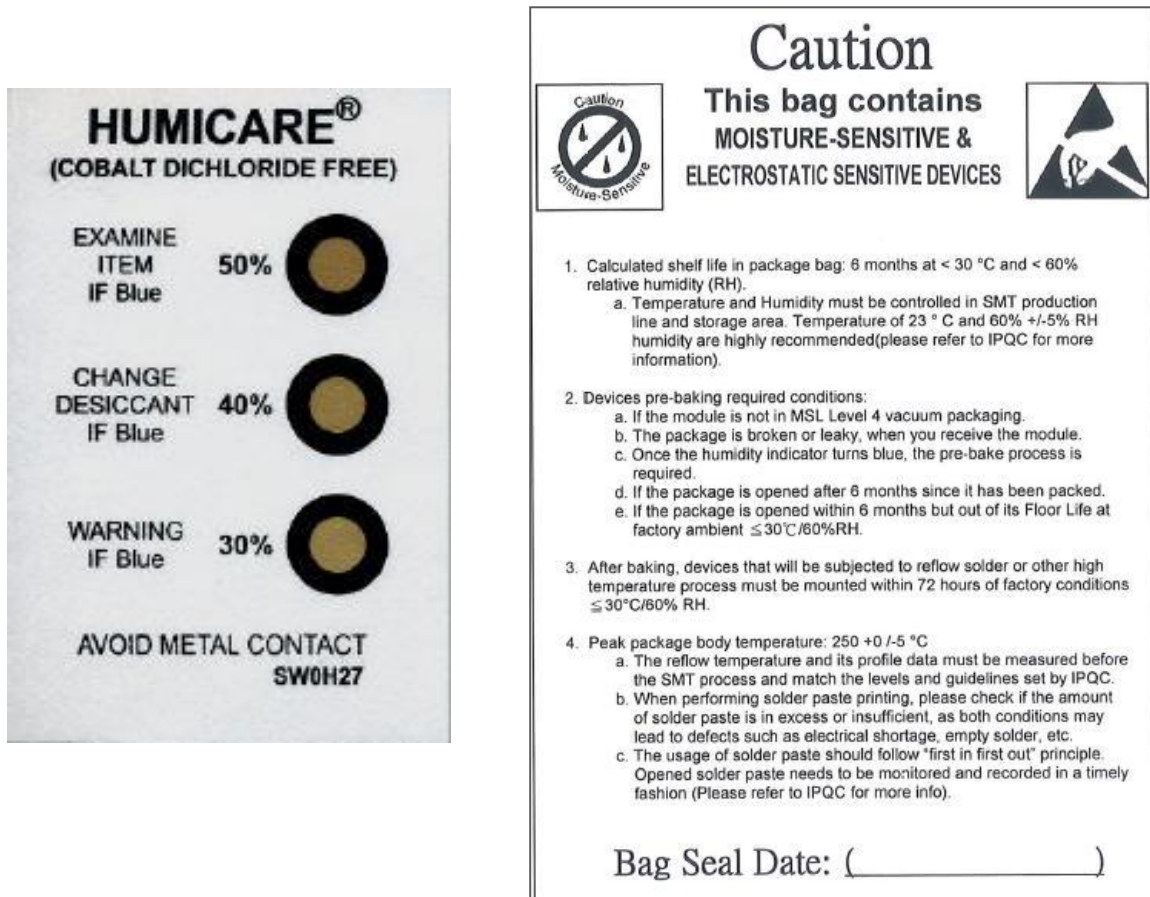

Fig. 5.3 Moisture Color Coded Card and Caution Label

GlobalTop modules are moisture sensitive. If the package of modules has stored under the condition of **non-condensing storage environment (<30°C; RH 60%)** over 6 months, the modules will need to go through solder-reflow before SMT.

⚠ Prior to solder-reflow, pre-baking will be mandatory if the modules meet any of the conditions listed in the following section 5.3 "Conditions for Pre-baking".

5.3 Conditions For Pre-baking

Pre-baking will become necessary before the modules going through solder-reflow process if any condition listed below is met,:

1. The package of the module is broken or leaky when you receive it.
2. When the humidity indicator turns **blue**
3. The package is opened 6 months after the module was packaged.
4. The package is opened within 6 months but its Floor Life at factory ambient is affected ($\leq 30^{\circ}\text{C}$; RH 60%).
5. When the MSL (*Moisture Sensitivity Level*) of vacuumed module package is higher than Level 4 (level 1~4 are safe; please refer to the figure below):

LEVEL	FLOOR LIFE		SOAK REQUIREMENTS				
			STANDARD		ACCELERATED EQUIVALENT ¹		
					eV 0.40-0.48	eV 0.30-0.39	CONDITION
TIME	CONDITION	TIME (hours)	CONDITION	TIME (hours)	TIME (hours)	CONDITION	
1	Unlimited	$\leq 30^{\circ}\text{C}/85\% \text{RH}$	168 +5/-0	85 °C/85% RH	NA	NA	NA
2	1 year	$\leq 30^{\circ}\text{C}/60\% \text{RH}$	168 +5/-0	85 °C/60% RH	NA	NA	NA
2a	4 weeks	$\leq 30^{\circ}\text{C}/60\% \text{RH}$	696 ² +5/-0	30 °C/60% RH	120 +1/-0	168 +1/-0	60 °C/60% RH
3	168 hours	$\leq 30^{\circ}\text{C}/60\% \text{RH}$	192 ² +5/-0	30 °C/60% RH	40 +1/-0	52 +1/-0	60 °C/60% RH
4	72 hours	$\leq 30^{\circ}\text{C}/60\% \text{RH}$	96 ² +2/-0	30 °C/60% RH	20 +0.5/-0	24 +0.5/-0	60 °C/60% RH
5	48 hours	$\leq 30^{\circ}\text{C}/60\% \text{RH}$	72 ² +2/-0	30 °C/60% RH	15 +0.5/-0	20 +0.5/-0	60 °C/60% RH
5a	24 hours	$\leq 30^{\circ}\text{C}/60\% \text{RH}$	48 ² +2/-0	30 °C/60% RH	10 +0.5/-0	13 +0.5/-0	60 °C/60% RH
6	Time on Label (TOL)	$\leq 30^{\circ}\text{C}/60\% \text{RH}$	TOL	30 °C/60% RH	NA	NA	NA

Figure 5.4 Moisture Sensitivity Level chart

Please note that the modules **must get solder-reflow 72 hours after pre-baking**. This maximum time is otherwise known as "Floor Life". If the waiting time exceeds 72 hours, the module may be damaged (cracks / de-lamination, etc.) during solder-reflow process due to excessive moisture pressure.

5.4 Drying

If the modules are exposed to high temperature in solder-reflow process, the moisture vapor pressure inside the modules will increase greatly. To prevent delaminating, cracking or “popcorn” effect* to the module, it may need to undergo pre-baking procedure prior to any high temperature or solder reflow process. The recommended baking time for GlobalTop GNSS module is as follows:

⇒ **50°C for 4 hours, when humidity condition RF is about 30% ~ 50%.**

Once baked, the module’s floor life will “reset”, which means the module will remain in normal factory condition for next 72 hours for solder-reflow process.

**Popcorn effect: when the IC/module “pops” because the moisture inside the package expands in the reflow process.*

-  **Please limit the number of times for GNSS modules undergoing baking process, as repeated baking process will affect performance of wetting on the SMD pad contacts. This applies to all SMT devices.**

-  **Risk of Oxidation: Baking SMD packages may cause oxidation and/or intermetallic growth of terminations, which if excessive can result in problems of solderability during board assembly. The temperature and time for baking SMD packages are therefore limited by solderability considerations. The cumulative bake time at a temperature greater than 90°C and up to 125°C shall not exceed 96 hours. Bake temperatures higher than 125°C are not allowed.**

5.5 ESD Handling



Please follow the precautions addressed below carefully to prevent severe damage to GNSS modules.

GlobalTop modules are sensitive to electrostatic discharges and thus are Electrostatic Sensitive Devices (ESD). Handle the GNSS modules particularly to its patch antenna (if included) and RF_IN pin carefully. Please follow the standard ESD safety practices stated below:

- Unless there is a galvanic coupling between the local GND and the PCB GND, then the first point of contact when handling the PCB shall always be between the local GND and PCB GND.
- Before working with RF_IN pin, please make sure the GND is connected
- When working with RF_IN pin, do not contact any charged capacitors or materials that can easily develop or store charges such as patch antenna, coax cable, soldering iron.
- Please do not touch the mounted patch antenna, to prevent electrostatic discharge from the RF input
- When soldering RF_IN pin, please make sure to use an ESD safe soldering iron tip.

6. Reflow Soldering Temperature Profile

The following reflow temperature profile was evaluated by GlobalTop and has been proven to be reliable qualitatively. Please contact us beforehand if you plan to solder this component using a deviated temperature profile as it may cause significant damage to our module and your device.

All the information in this datasheet can only be used for Pb-free manufacturing process.

6.1 SMT Reflow Soldering Temperature Profile (For Reference Only)

- ⇒ Average ramp-up rate (25 ~ 150°C): 3°C/sec. max.
- ⇒ Average ramp-up rate (270°C to peak): 3°C/sec. max.
- ⇒ Preheat: 175 ± 25°C, 60 ~ 120 seconds
- ⇒ Temperature maintained above 217°C: 60~150 seconds
- ⇒ Peak temperature: 250 +0/-5°C, 20~40 seconds
- ⇒ Ramp-down rate: 6°C/sec. max.
- ⇒ Time 25°C to peak temperature: 8 minutes max.

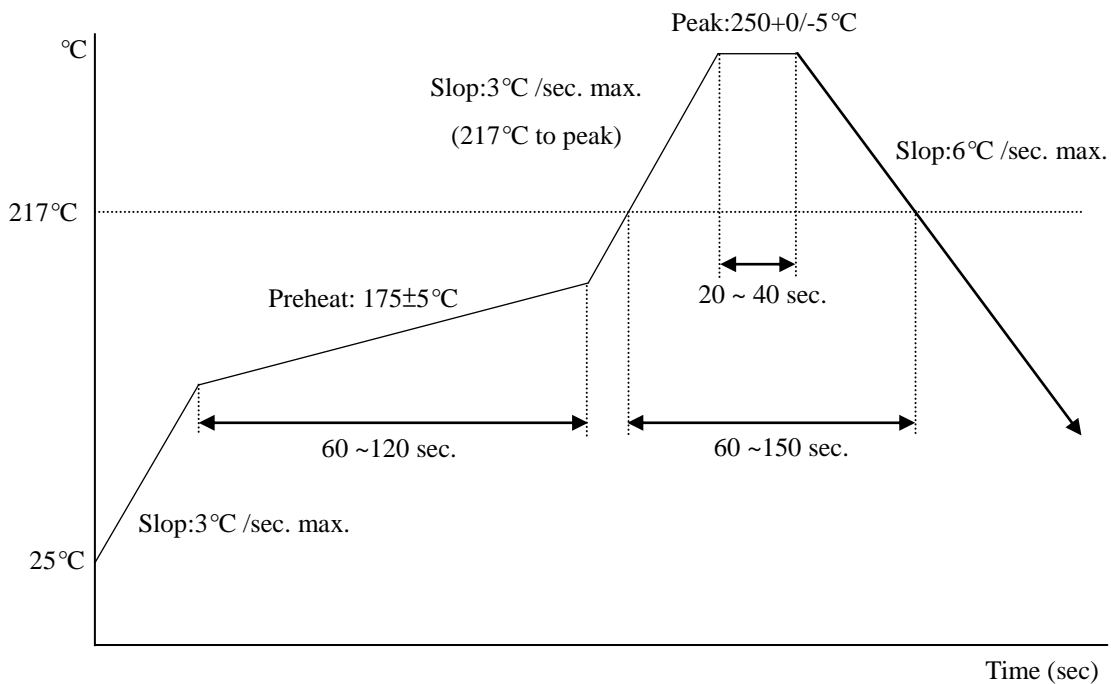

Fig. 6.1 SMT reflow profile

Description	Suggestions	Notes
1 Before proceeding with the reflow-soldering process, the GNSS modules might need to be pre-baked. Please refer to item 5.6 "Pre-Baking Required Conditions".	Pre-bake Time: 4 Hours @ 50°C to 60°C.	The maximum tolerated temperature for the tray is 100°C. After pre-baking, make sure the temperature is cooled down to 35°C or below, to prevent tray deformation.
2 PCBA (along with the patch antenna) is highly endothermic during the reflow-soldering process. Extra care must be paid to the GNSS module's solder joints if any signs of cold welding or false welding.	The parameters of the reflow temperature must be set accordingly to module's reflow-soldering temperature profile.	Double check to see if the surrounding components around the GNSS module are displaying symptoms of cold weld(ing) or false welding.
3 Special attentions to PCBA board are needed during reflow-soldering process. See if the PCBA board is bended or deformed, possibly due to the weight of the module. If so, this will cause concerns at the latter half of the production process.	A loading carrier fixture must be used with PCBA if the reflow soldering process applies rail conveyors for the production.	If PCBA board is bended or deformed, it may collide into one another during the unloading process.
4 Before the PCBA getting reflow-soldering process, the operator must check with own eyes to see if there is positional offset to the module, as it would be difficult to readjust after the module has gone through reflow-soldering process.	The operators must check with own eyes and readjust the position before reflow-soldering process.	If the operator plans to readjust the module position, please do not touch the patch antenna while the module is hot in order to prevent rotational offset between the patch antenna and module

Note: References to patch antenna is referred to GNSS modules with integrated Patch-on-top antennas (Gms Module Series), and may not be applicable to all GNSS modules.

	Description	Suggestions	Notes
5	Before handling the PCBA, they must be cooled to 35°C or below after they have undergone a reflow-soldering process, in order to prevent positional shift which may occurred when the module is still hot.	1. One may use electric fans behind the reflow machine to cool them down. 2. Cooling the PCBA can prevent the module from shifting due to fluid effect.	It is very easy to cause positional offset to the module and its patch antenna when handling the PCBA under high temperature.
6	1. When separating the PCBA panel into individual pieces using the V-Cut process, special attentions are needed to ensure that there are sufficient gap between patch antennas. 2. If V-Cut/cutting must be done manually, please make sure the operators are not using excessive force as that may cause rotational offset to the patch antennas.	1. The blade and the patch antenna must have a distance gap greater than 0.6mm. 2. Do not use patch antenna as the leverage point when separating the panels by hand.	1. Test must be performed first to determine if V-Cut process is going to be used. Ensure that there is enough space between the blade and the patch antenna so that they do not touch one another. 2. An uneven amount of manual force applied to the separation will likely to cause positional shift in patch antenna and module.
7	When separating panel into individual pieces during latter half of the production process, special attentions are needed to ensure the patch antennas do not come in contact with one another in order to prevent chipped corners or positional shifts.	Use tray to separate individual pieces.	It is possible to chip corner and/or cause a shift in position if patch antennas come in contact with each other.

Note: References to patch antenna is referred to GNSS modules with integrated Patch-on-top antennas (Gms Module Series), and may not be applicable to all GNSS modules.

Other Cautionary Notes on Reflow-Soldering Process:

1. Module may need pre-baking **before** going through SMT solder reflow process. Please refer to Section 5.3.
2. The usage of solder paste should follow "FIFO (First-in-First-out)" principle. Opened solder paste needs to be monitored and recorded in a timely manner (please refer to IPQC standards for related documentation and examples).
3. Temperature and humidity must be controlled within SMT production line and storage area. Temperature of 23°C, 60±5% RH humidity is recommended (please refer to IPQC standards for related documentation and examples).
4. When performing solder paste printing, please notice if the amount of solder paste is excessive or insufficient, as both conditions may lead to defects such as electrical shortage, empty solder and etc.
5. Make sure the vacuum mouthpiece is able to bear the weight of the GNSS module to prevent positional shift during the loading process.
6. Before the PCBA going through the reflow-soldering process, the operator must visually check if there are positional offset to the module.
7. The reflow temperature and its profile data must be measured before the SMT process and match the levels and guidelines set by IPQC.
8. If SMT protection line is running a double-sided process for PCBA, please process GNSS module during the second pass only to avoid repeated reflow exposures of the GNSS module. Please contact GlobalTop beforehand if you must process GNSS module during the 1st pass of double-side process.

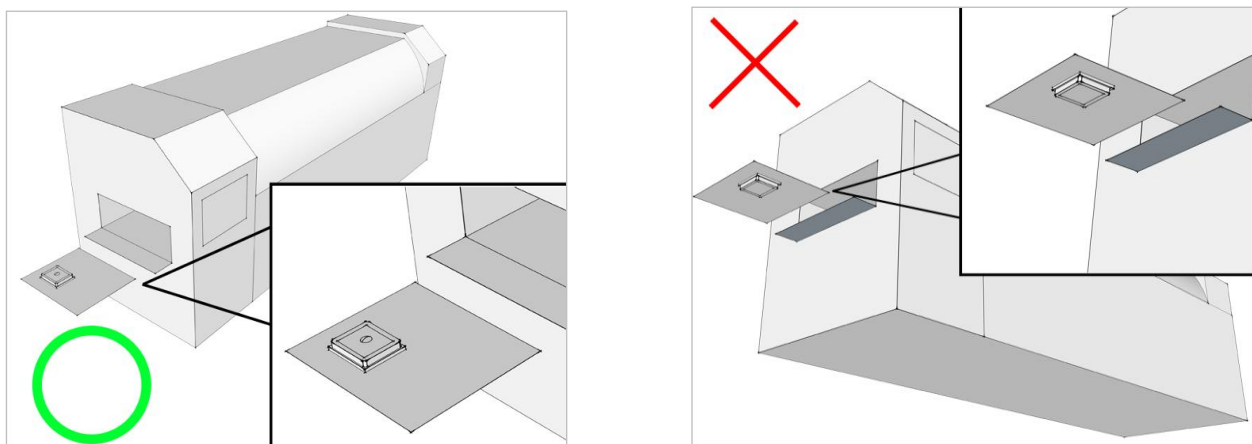

Fig. 6.1 Place GNSS module top side up when running reflow-solder process. Do not invert.

6.2 Manual Soldering

Soldering iron:

Heat temperature: under 380°C | Time: under 3 sec.

Notes:

1. Do not touch the soldering pads on the surface of the PCB board directly, to prevent further oxidation.
2. The solder paste must be defrosted to room temperature before use so it can return to its optimal working temperature. The time required for this procedure is unique and dependent on the properties of the solder paste used.
3. The steel plate must be properly assessed before and after use, so its measurement stays strictly within the specification set by SOP.
4. Be cautious to the spacing between soldering joint, as excessive soldering may cause electrical shortage
5. Do not use extensive amount of flux to avoid possible siphon effects on neighboring components which may lead to electrical shortage.
6. Do not use the heat gun for long periods of time when removing the shielding or inner components of the GNSS module, as it is very likely to cause a shift to the inner components and will leads to electrical shortage.

7. Contact Information

GlobalTop Technology Inc.

Address: No.16 Nan-ke 9th Road Science-based Industrial Park, Tainan 741, Taiwan

Tel: +886-6-5051268

Fax: +886-6-5053381

Website: www.gtop-tech.com

Email: sales@gtop-tech.com

Компания «Океан Электроники» предлагает заключение долгосрочных отношений при поставках импортных электронных компонентов на взаимовыгодных условиях!

Наши преимущества:

- Поставка оригинальных импортных электронных компонентов напрямую с производств Америки, Европы и Азии, а так же с крупнейших складов мира;
- Широкая линейка поставок активных и пассивных импортных электронных компонентов (более 30 млн. наименований);
- Поставка сложных, дефицитных, либо снятых с производства позиций;
- Оперативные сроки поставки под заказ (от 5 рабочих дней);
- Экспресс доставка в любую точку России;
- Помощь Конструкторского Отдела и консультации квалифицированных инженеров;
- Техническая поддержка проекта, помощь в подборе аналогов, поставка прототипов;
- Поставка электронных компонентов под контролем ВП;
- Система менеджмента качества сертифицирована по Международному стандарту ISO 9001;
- При необходимости вся продукция военного и аэрокосмического назначения проходит испытания и сертификацию в лаборатории (по согласованию с заказчиком);
- Поставка специализированных компонентов военного и аэрокосмического уровня качества (Xilinx, Altera, Analog Devices, Intersil, Interpoint, Microsemi, Actel, Aeroflex, Peregrine, VPT, Syfer, Eurofarad, Texas Instruments, MS Kennedy, Miteq, Cobham, E2V, MA-COM, Hittite, Mini-Circuits, General Dynamics и др.);

Компания «Океан Электроники» является официальным дистрибьютором и эксклюзивным представителем в России одного из крупнейших производителей разъемов военного и аэрокосмического назначения «JONHON», а так же официальным дистрибьютором и эксклюзивным представителем в России производителя высокотехнологичных и надежных решений для передачи СВЧ сигналов «FORSTAR».



JONHON

«JONHON» (основан в 1970 г.)

Разъемы специального, военного и аэрокосмического назначения:

(Применяются в военной, авиационной, аэрокосмической, морской, железнодорожной, горно- и нефтедобывающей отраслях промышленности)

«FORSTAR» (основан в 1998 г.)

ВЧ соединители, коаксиальные кабели, кабельные сборки и микроволновые компоненты:

(Применяются в телекоммуникациях гражданского и специального назначения, в средствах связи, РЛС, а так же военной, авиационной и аэрокосмической отраслях промышленности).



Телефон: 8 (812) 309-75-97 (многоканальный)

Факс: 8 (812) 320-03-32

Электронная почта: ocean@oceanchips.ru

Web: <http://oceanchips.ru/>

Адрес: 198099, г. Санкт-Петербург, ул. Калинина, д. 2, корп. 4, лит. А