

## QPI-12LZ Filter Carrier Board for 48 V V•I Chip EMI Evaluation

### Contents

Introduction . . . . .	Page 1
Board overview . . . . .	Page 2
Bill of materials . . . . .	Page 2
Schematic . . . . .	Page 2
Board assembly . . . . .	Page 3
V•I Chip mounting configurations . . . . .	Page 3
EMI bypass configurations . . . . .	Page 4
EMI performance and test set up . . . . .	Page 4
Typical EMI performance . . . . .	Page 5
Mechanical drawings . . . . .	Page 6
Ordering information . . . . .	Page 6
Additional resources . . . . .	Page 6

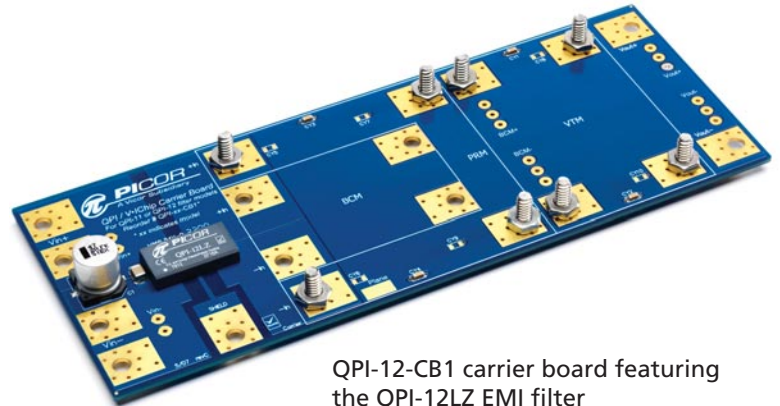

QPI-12-CB1 carrier board featuring the QPI-12LZ EMI filter

### Introduction

The QPI-12-CB1 carrier board is an evaluation board platform designed to demonstrate the EMI capabilities of a QPI-12LZ filter, with any combination of 48 V input PRM / VTM or BCM evaluation boards. The QPI-12-CB1 board includes a pre-mounted filter along with some additional components necessary to demonstrate the full functionality of the filter, along with mounting areas for V•I Chip evaluation boards. This User's Guide provides basic instructions for assembly and use of the board. Further information on the functionality of the V•I Chip boards, as well as the QPI-12LZ can be found in the V•I Chip Evaluation Board User's Guide as well as the V•I Chip and QPI-12LZ data sheets.

### QPI-12LZ Product Description

The QPI-12LZ EMI filter is specifically designed to attenuate conducted common-mode (CM) and differential-mode (DM) noise of Vicor's V•I Chip products to comply with the CISPR22 standard requirements for conducted noise measurements. The filter is designed to operate up to 80 Vdc continuous, with a 100 Vdc surge for 100 ms, and supports 7 A loads up to 60°C without derating.

Designed for the telecom bus range, the V•I Chip EMI Filter supports the PICMG<sup>®</sup> 3.0 specification for filtering system boards to the EN55022 Class B limits.

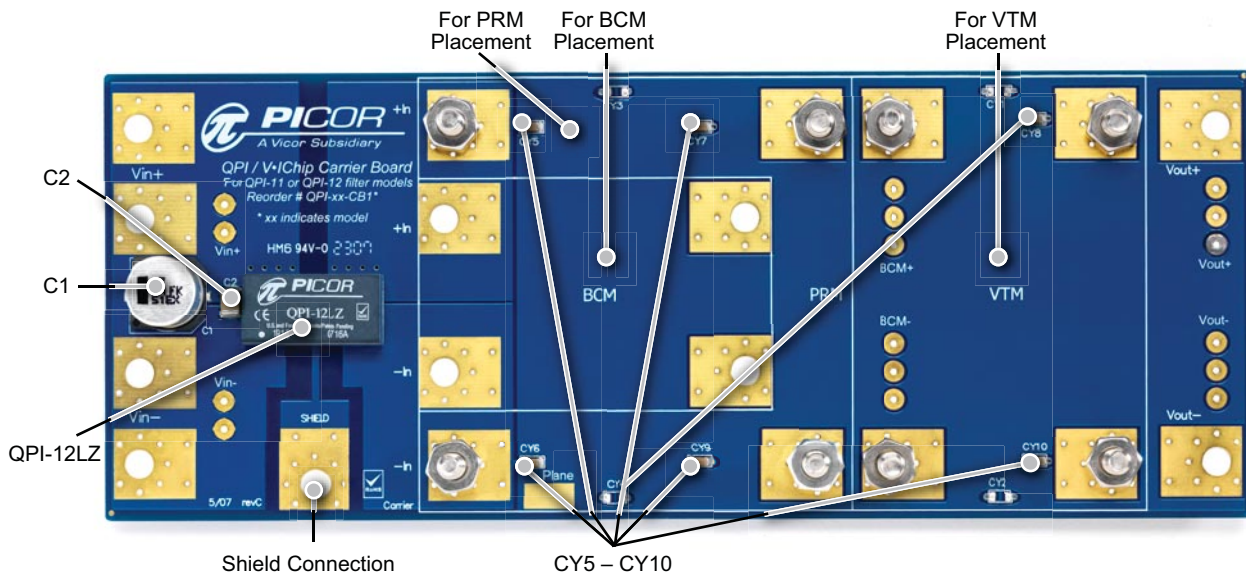

### Bill of Materials

Ref Designator	Description
QPI	QPI-12LZ SiP
C1	Capacitor, electrolytic, 47 uF, 100 V
C2	Capacitor, ceramic, 2.2 uF, 100 V
CY5 thru CY10	Capacitor, X7R ceramic, 4.7 nF, 1,000 V
Hardware	Machine screw, pan head, 0.373", 1/2" long, #10-24 thread
Hardware	Machine nut, hex, 3/8", #10-24 thread
CY1 thru CY4	Optional Y-Cap configuration (not populated)

Figure 1 – QPI-12-CB1 board overview

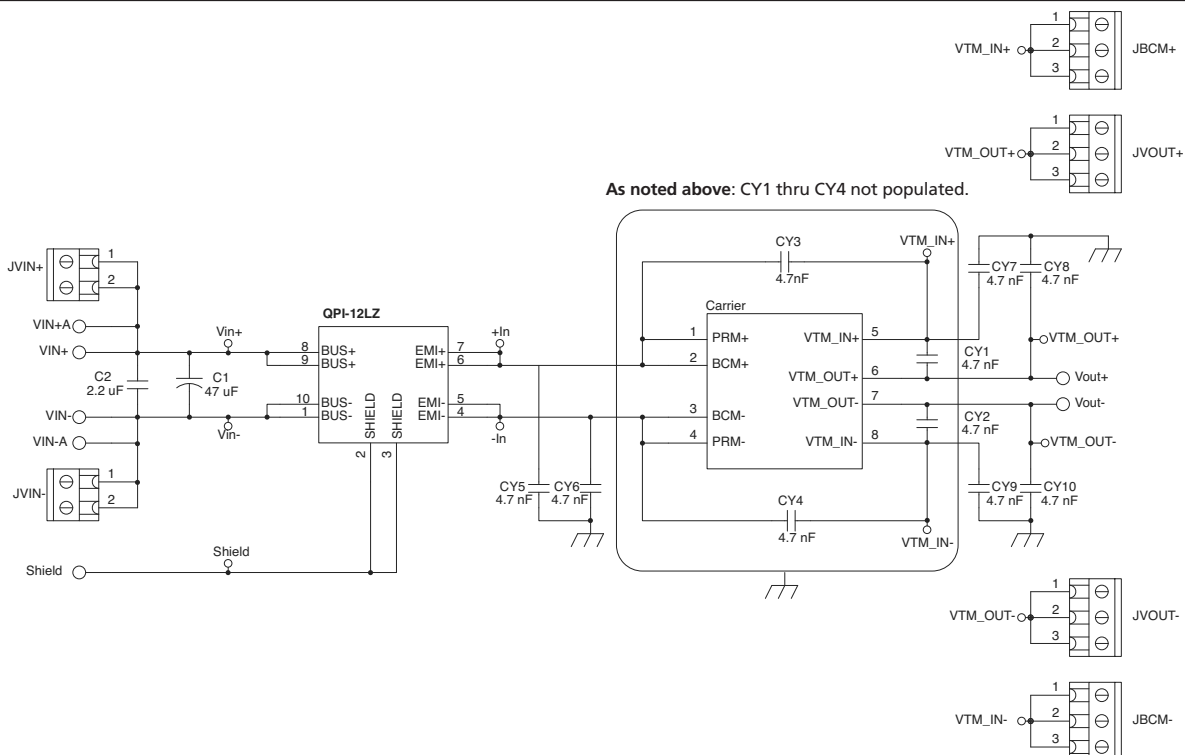

Figure 2 – QPI-12-CB1 carrier board schematic

## Board Assembly

The V•I Chip evaluation boards should be attached to the carrier board using the hardware provided. Begin by removing the top nuts from the bolts in the space provided for mounting the evaluation board. Check to see that the lower bolts are tightened. Remove rubber spacers from the V•I Chip evaluation board(s). Place the V•I Chip evaluation board on the bolts. Make sure that the evaluation board is placed in the proper input to output orientation with respect to the carrier board (the input side will have the capacitor). Replace the top nuts and tighten gently with a wrench. Attach input and output leads, be careful to confirm proper polarity before powering up.

When using the carrier board pay special attention to the wiring and grounding. Wires should be kept as short as possible and positioned to minimize radiated noise pick-up on the QPI-12LZ.

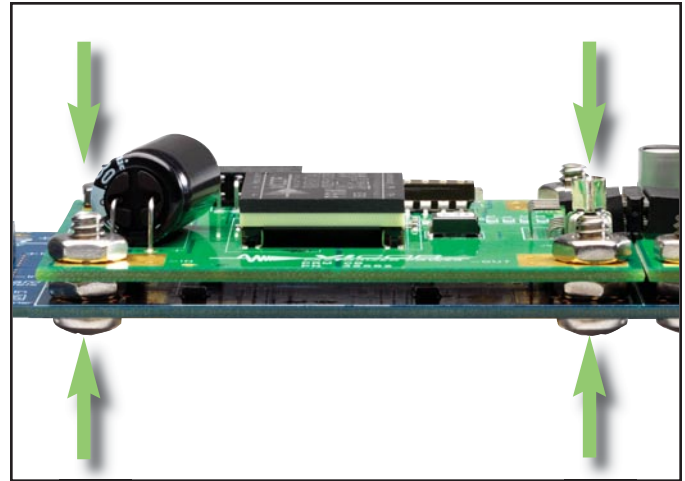

Figure 3 – Side view hardware assembly

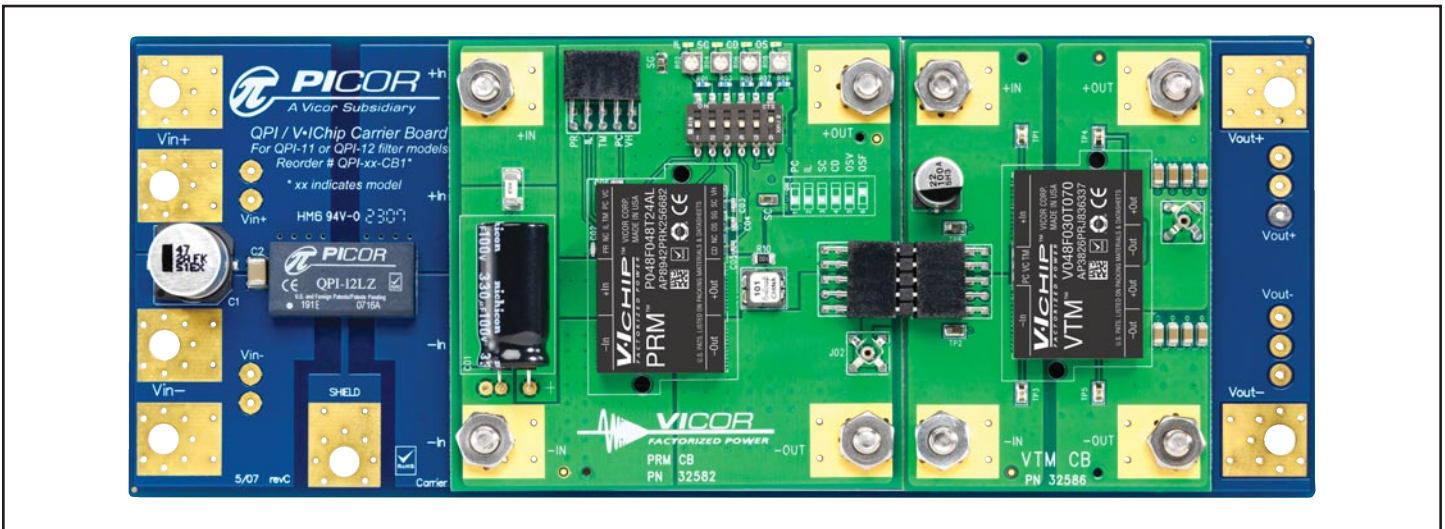

Figure 4 – QPI-12-CB1 carrier board assembled with PRM and VTM evaluation boards

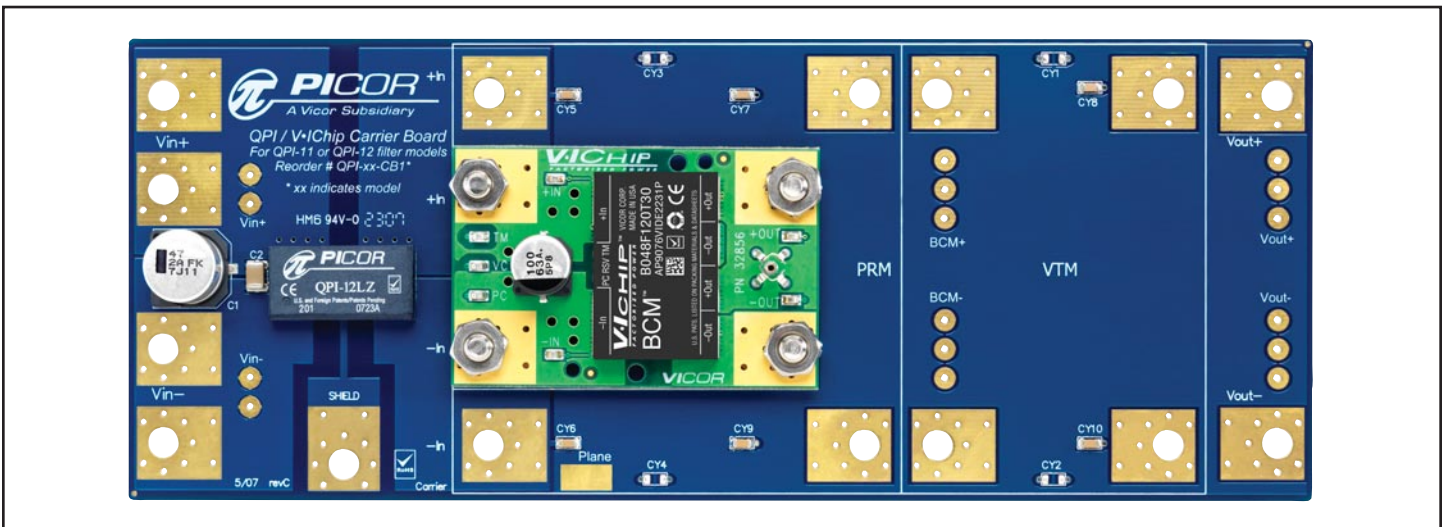

Figure 5 – QPI-12-CB1 carrier board assembled with BCM evaluation board

# EMI Bypass Configurations

EMI bypass capacitors ("Y" capacitors) are an essential element in a switch-mode DC-DC filter application as these capacitors provide a return path for common-mode noise currents to their source; so careful attention to bypass capacitor implementation is essential for a successful EMI filter design. This carrier board is preconfigured in a "base-plate" EMI topology, which uses six "Y" capacitors (only four are actually used in a BCM configuration), as illustrated in Figure 7 below. This is the preferred topology for VI Chip applications. The carrier board can be manually reconfigured to an "open frame" topology, which uses four "Y" caps in a PRM/VTM combination (two for a BCM), as shown in Figure 8. The open-frame approach may attenuate certain load dependent noise better than the base-plate method. The carrier board provides an ideal test vehicle for making a comparison between the two "Y" capacitor configurations. To reconfigure to "open frame" carefully remove capacitors CY5 through CY10 and place four of those six capacitors in the positions marked as CY1 through CY4.

using the basic base-plate standard "Y" cap configuration. Figure 7 shows the basic EMI measurement set up that was used to achieve these results. Figure 8 shows the alternate set up method when converting to the open-frame approach.

In Figure 7 (base-plate method), capacitors CY5 through CY10 represent the recirculation capacitors that are connected to each of the four input and output terminals, then are commoned to a shield plane that has been created underneath the converter. Since the PRM/VTM pair is similar to a conventional converter, which is split into to halves, two additional "Y" caps (CY7 and CY9) were added to the PRM's output (the input to the VTM), referenced to the shield plane.

In Figure 8 (open-frame method), four "Y" capacitors are used (CY1 through CY4) rather than the two "Y" caps that a conventional converter would require, once again because of the topology split created by the pair.

In a BCM application there is no topology split so the set up would require two fewer capacitors for either configuration. The open-frame method would only need one pair of input an output caps, referenced to the shield plane on either side of the BCM. And for open-frame method a pair of "Y" caps across the positive input to positive output, and negative input and negative output would be sufficient.

## EMI Performance and Test Set Up

The EMI plots in Figures 9 through 14 are the total noise measurements, on both the positive and negative lines of the QPI-12LZ with various V•I Chip configurations,

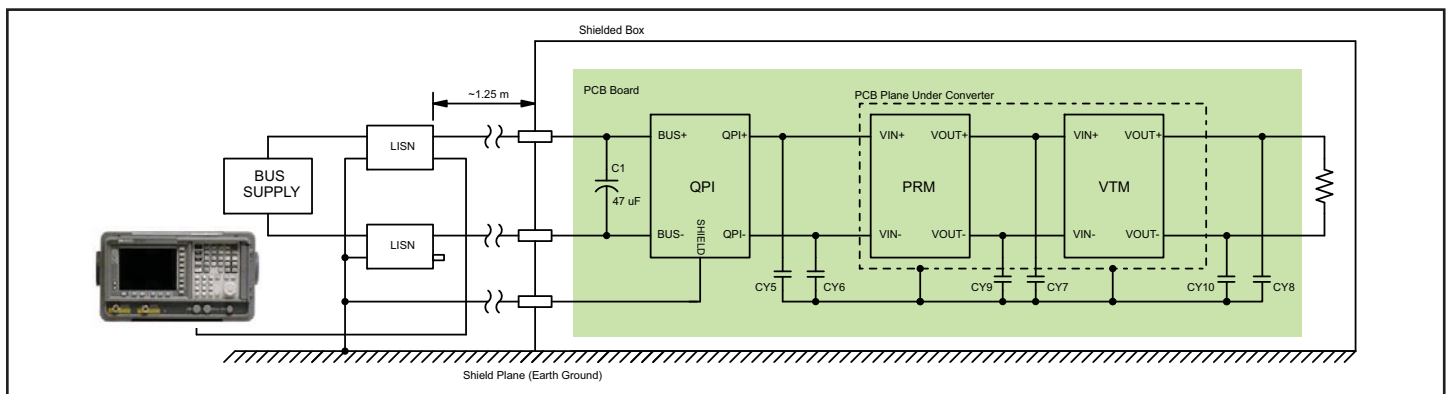

Figure 7 – Basic EMI measurement setup for "base-plate" configuration.

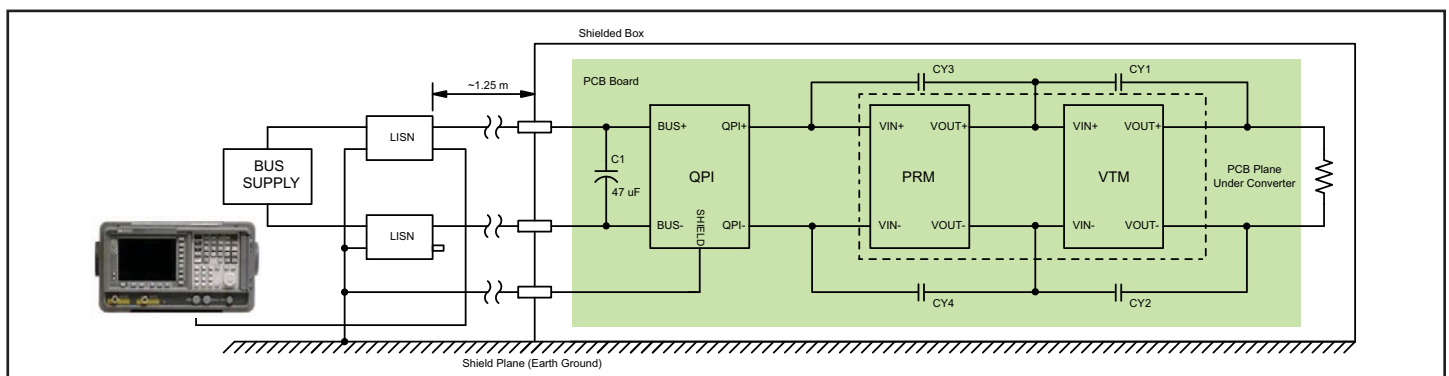
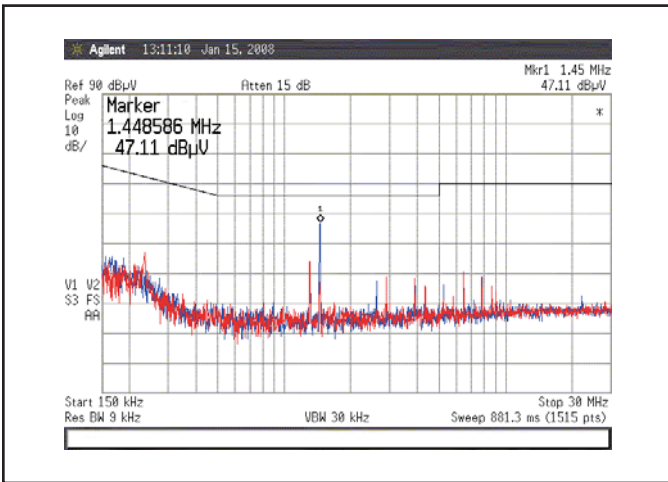
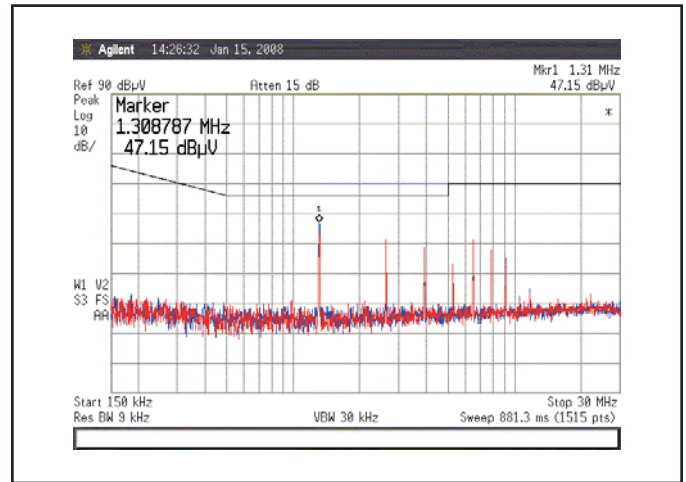

Figure 8 – Basic EMI measurement setup for "open-frame" configuration.



**Figure 9** – Total noise QPI-12LZ\* with 48 V input PRM and 3V output VTM. 3.27 A input current. 160 W output load.



**Figure 12** – Total noise QPI-12LZ\* with 48 V input, 3 V output BCM. 3.18 A input current. 160 W output load.

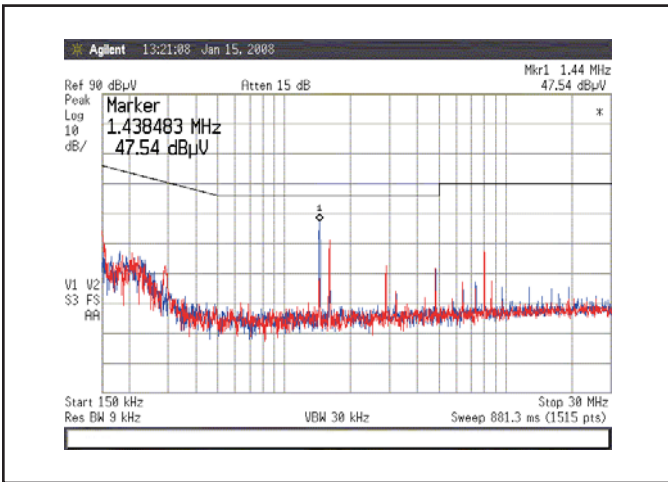

**Figure 10** – Total noise QPI-12LZ\* with 48 V input PRM and 12 V output VTM. 4.03 A input current. 180 W output load.

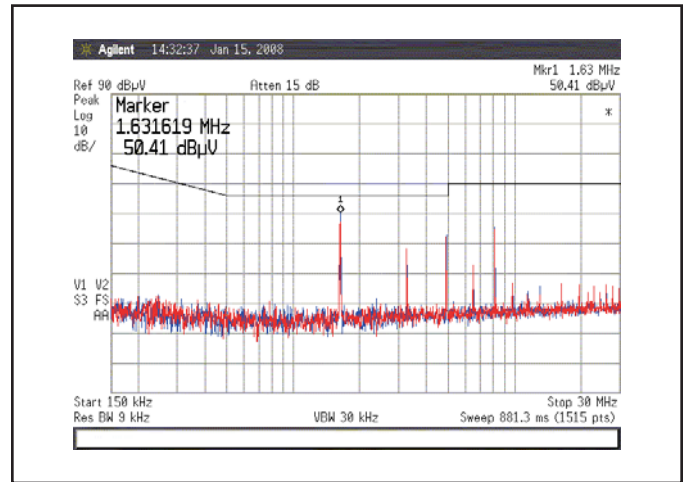

**Figure 13** – Total noise QPI-12LZ\* with 48 V input, 12 V output BCM. 3.75 A input current. 180 W output load.

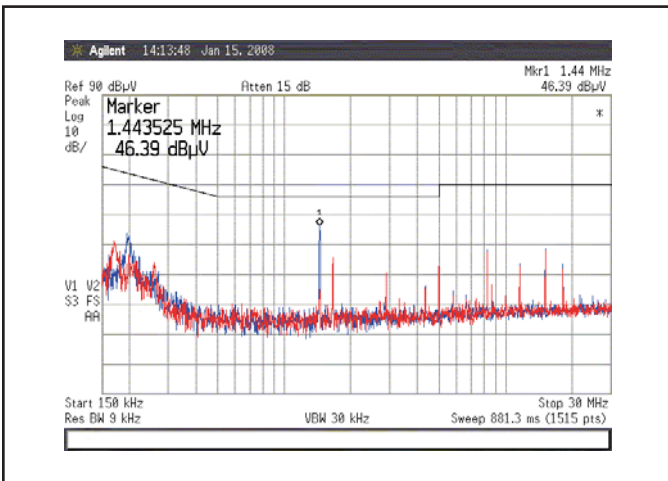

**Figure 11** – Total noise QPI-12LZ\* with 48 V input PRM and 48 V output VTM. 3.45 A input current. 160 W output load.

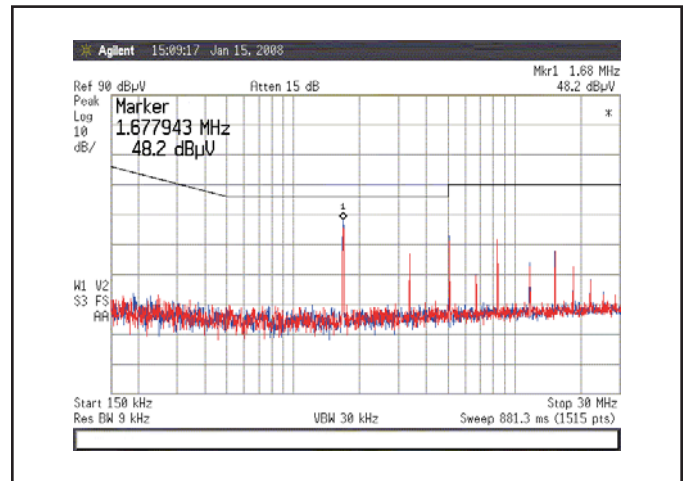

**Figure 14** – Total noise QPI-12LZ\* with 48 V input, 48 V output BCM. 3.20 A input current. 153 W output load.

\* These EMI plots are actually based on QPI-10LZ, which includes the same filter elements but includes integrated hot-swap.

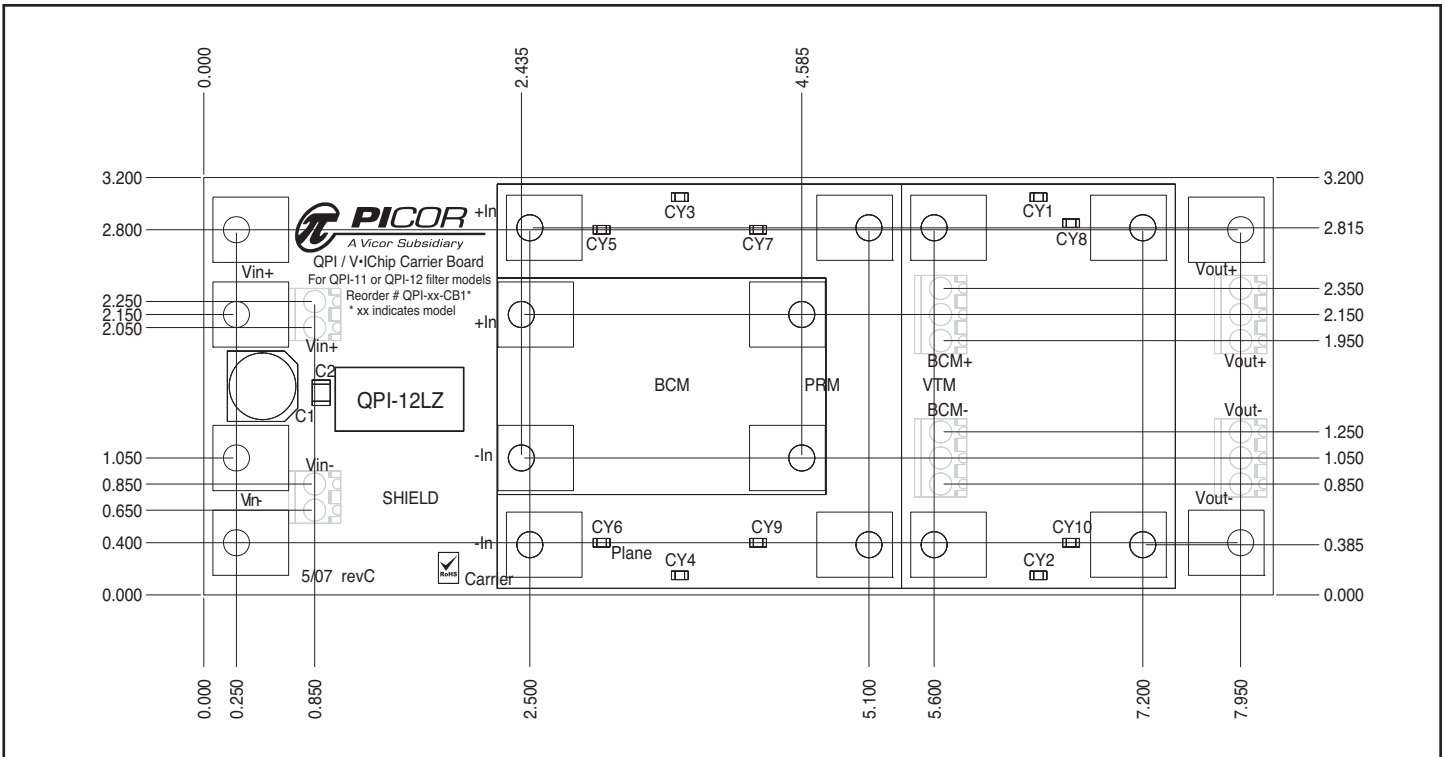

Figure 17 – Mechanical drawing for QPI-12-CB1

## Ordering Information

Carrier Board Part Number	Compatible V•I Chip Evaluation Boards (sold separately)*
QPI-12-CB1	PRMs: P048F048T12AL-CB, P048F048T24AL-CB, P048F048T17AL-CB, P048F048T32AL-CB,
	VTMs: All 48 V input models
	BCMs: All 48 V input models

\* Some V•I Chip products exceed the current rating and therefore may not be compatible when operating at full load

## Additional Resources Online

QPI-12LZ Data Sheet  
[http://vicorpower.com/picorpower/data\\_sheets/#input\\_filters](http://vicorpower.com/picorpower/data_sheets/#input_filters)

V•I Chip Data Sheets and User Guides  
<http://vicorpower.com/products/vichip/>

Компания «Океан Электроники» предлагает заключение долгосрочных отношений при поставках импортных электронных компонентов на взаимовыгодных условиях!

Наши преимущества:

- Поставка оригинальных импортных электронных компонентов напрямую с производств Америки, Европы и Азии, а так же с крупнейших складов мира;
- Широкая линейка поставок активных и пассивных импортных электронных компонентов (более 30 млн. наименований);
- Поставка сложных, дефицитных, либо снятых с производства позиций;
- Оперативные сроки поставки под заказ (от 5 рабочих дней);
- Экспресс доставка в любую точку России;
- Помощь Конструкторского Отдела и консультации квалифицированных инженеров;
- Техническая поддержка проекта, помощь в подборе аналогов, поставка прототипов;
- Поставка электронных компонентов под контролем ВП;
- Система менеджмента качества сертифицирована по Международному стандарту ISO 9001;
- При необходимости вся продукция военного и аэрокосмического назначения проходит испытания и сертификацию в лаборатории (по согласованию с заказчиком);
- Поставка специализированных компонентов военного и аэрокосмического уровня качества (Xilinx, Altera, Analog Devices, Intersil, Interpoint, Microsemi, Actel, Aeroflex, Peregrine, VPT, Syfer, Eurofarad, Texas Instruments, MS Kennedy, Miteq, Cobham, E2V, MA-COM, Hittite, Mini-Circuits, General Dynamics и др.);

Компания «Океан Электроники» является официальным дистрибьютором и эксклюзивным представителем в России одного из крупнейших производителей разъемов военного и аэрокосмического назначения «JONHON», а так же официальным дистрибьютором и эксклюзивным представителем в России производителя высокотехнологичных и надежных решений для передачи СВЧ сигналов «FORSTAR».



## JONHON

«JONHON» (основан в 1970 г.)

Разъемы специального, военного и аэрокосмического назначения:

(Применяются в военной, авиационной, аэрокосмической, морской, железнодорожной, горно- и нефтедобывающей отраслях промышленности)

«FORSTAR» (основан в 1998 г.)

ВЧ соединители, коаксиальные кабели, кабельные сборки и микроволновые компоненты:

(Применяются в телекоммуникациях гражданского и специального назначения, в средствах связи, РЛС, а так же военной, авиационной и аэрокосмической отраслях промышленности).



Телефон: 8 (812) 309-75-97 (многоканальный)

Факс: 8 (812) 320-03-32

Электронная почта: [ocean@oceanchips.ru](mailto:ocean@oceanchips.ru)

Web: <http://oceanchips.ru/>

Адрес: 198099, г. Санкт-Петербург, ул. Калинина, д. 2, корп. 4, лит. А