



# MIC4605 Evaluation Board

## 85V Half-Bridge MOSFET Drivers with Adaptive Dead Time and Shoot-Through Protection

### General Description

The MIC4605 is an 85V half-bridge MOSFET driver that features adaptive-dead-time and shoot-through protection. The adaptive-dead-time circuitry actively monitors the half-bridge outputs to minimize the time between high-side and low-side MOSFET transitions, thus maximizing power efficiency. Anti-shoot-through circuitry prevents erroneous inputs and noise from turning both MOSFETs on at the same time. Additionally, the MIC4605's adjustable gate drive sets the gate drive voltage to VDD for optimal MOSFET  $R_{DS(ON)}$ , which minimizes power loss due to the MOSFET's  $R_{DS(ON)}$ .

### Requirements

At a minimum, the evaluation board requires a 5.5V to 16V power supply to power the VDD terminal (J1) of the MIC4605 and another supply (up to 85V) may be used to power the MOSFETs connected to the VIN terminal (J2). A pulse generator or the output of a PWM control IC may be connected to the HI and LI terminals (-1), or PWM single input (-2).

### Precautions

There is no reverse input protection on this board. When connecting the input sources, make sure that the correct polarity is observed.

Under extreme load conditions and with a high supply voltage (>48V) connected to the VIN terminal (J2), input transients can be quite large if long test leads are used. In such cases a 100 $\mu$ F, 100V electrolytic capacitor is needed across the VIN terminals to prevent overvoltage damage to the IC. This can be removed if a clean supply voltage on VIN is always guaranteed.

Datasheets and support documentation are available on Micrel's web site at: [www.micrel.com](http://www.micrel.com).

### Getting Started

1. **Connect VIN supply between the VIN and GND terminals and VDD supply between the VDD and GND terminals.**

Connect a supply between the VIN terminal (J2) and the GND terminal (J3), paying careful attention to polarity and supply range ( $VIN \leq 85V$ ). Do not apply power until Step 5.

Connect a supply between the VDD terminal (J1) and the GND terminal (J3), paying careful attention to polarity and supply range ( $5.5V \leq VDD < 16V$ ). Do not apply power until Step 5.

2. **Connect the TTL-compatible HI and LI inputs (-1), or the PWM single input (-2).**

Connect the HI input (JP2) and LI input (JP3) to a pulse generator or the output of a PWM control IC. Ensure that they are non-overlapping signals and are TTL compatible logic-levels. The PWM single input replaces the HI input (JP2) for the -2 option.

3. **Monitor inputs and outputs.**

Monitor the inputs HI (JP2) and LI (JP3) or PWM (JP2) and outputs HO (JP1) and LO (JP4) with an oscilloscope.

4. **Connect motor across HS and GND or connect HS to GND.**

The simplest way to observe the MIC4605 operation is to connect a motor across the HS terminal (J8) and GND (J9). Alternatively the HS terminal (J8) can be shorted to GND (J9) with the VIN supply turned OFF. DC and AC parameters can be easily measured in this configuration.

5. **Turn-on supplies and HI/LI inputs.**

Turn-on the VDD power supply, followed by the VIN power supply. Turn on the HI and LI inputs (-1) or PWM single input (-2).

## Ordering Information

Part Number	Description
MIC4605-1YMT EV	Evaluation Board Featuring the MIC4605-1YMT Half-Bridge MOSFET Driver with Dual-TTL Inputs
MIC4605-2YMT EV	Evaluation Board Featuring the MIC4605-2YMT Half-Bridge MOSFET Driver with Dual-TTL Inputs
MIC4605-1YM EV	Evaluation Board Featuring the MIC4605-1YM Half-Bridge MOSFET Driver with Single-PWM Input
MIC4605-2YM EV	Evaluation Board Featuring the MIC4605-2YM Half-Bridge MOSFET Driver with Single-PWM Input

## Evaluation Board Performance

**MIC4605-1 166kHz Operation**  
Fan Load Showing LI, HI, LO, and HO Signals

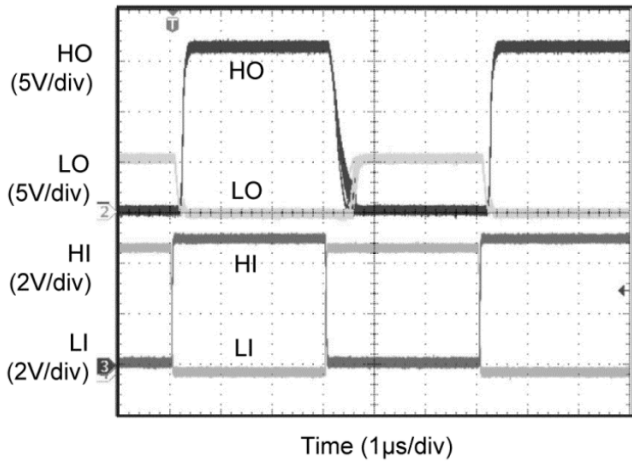

**MIC4605-1 166kHz Overlapping Inputs**  
Fan Load Showing LI, HI, LO, and HO Signals

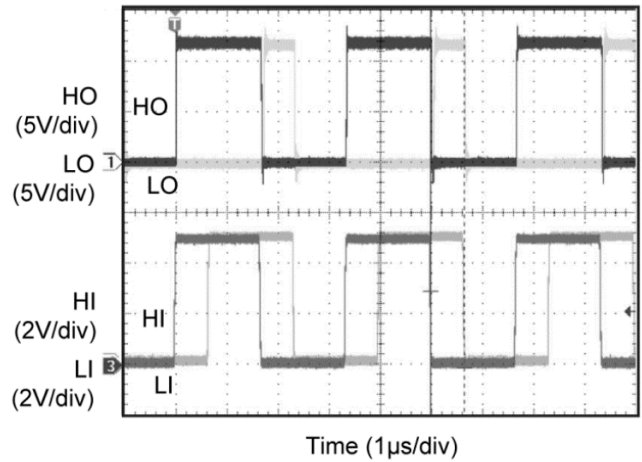

**MIC4605-1 Adaptive Dead Time (HS Ground)**  
Showing LI, HI, HO, and LO Signals

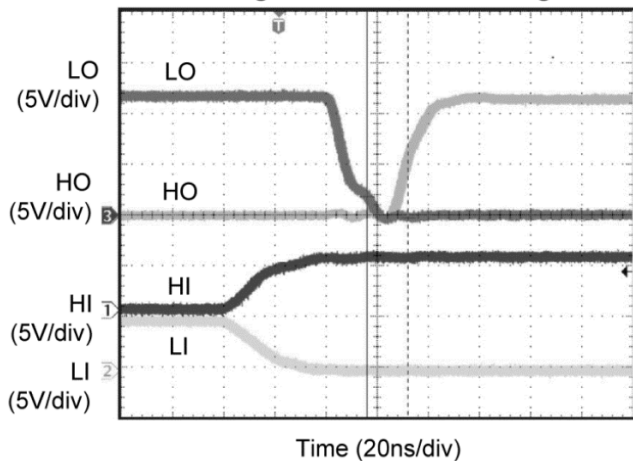

**MIC4605-2 VIN Turn-On (Hot Plug)**  
Fan Load Showing VDD, PWM, HO, and LO Signals

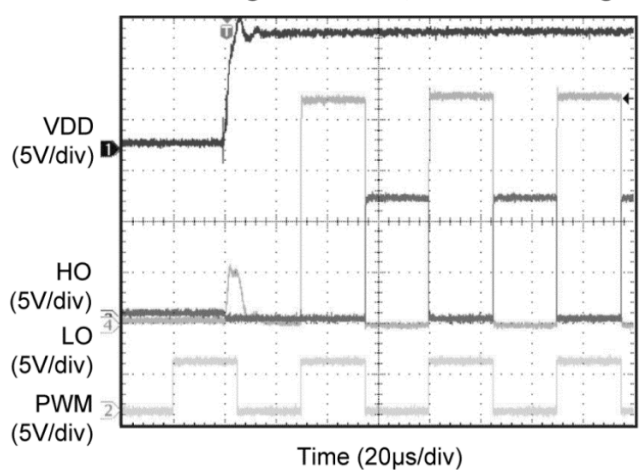

## Evaluation Board Schematic (MIC4605YM)

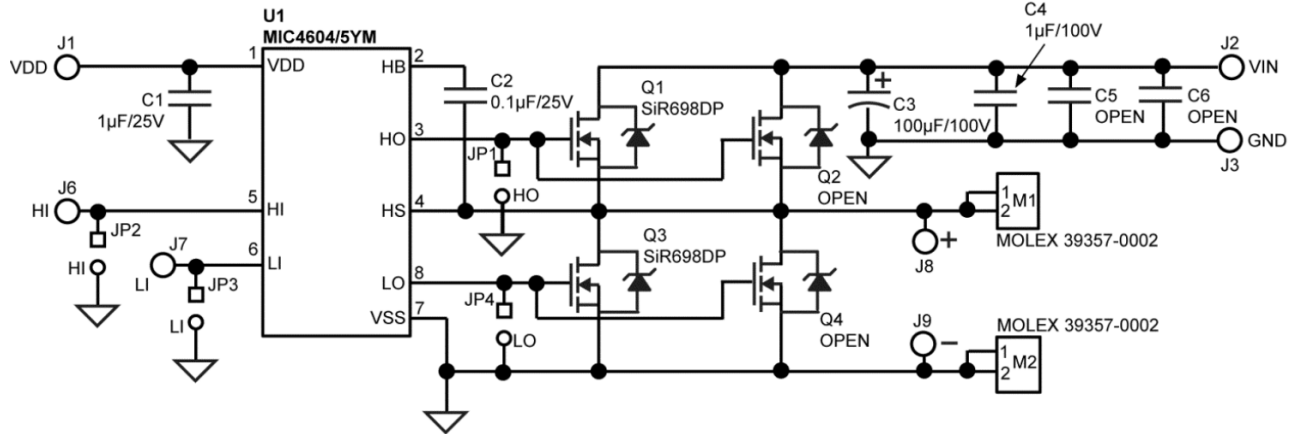

## Bill of Materials

Item	Part Number	Manufacturer	Description	Qty.
C1	C1608X7R1E105K	TDK <sup>(1)</sup>	1.0µF Ceramic Capacitor, 25V, X7R, Size 0603	1
	GRM188R71E105KA12D	Murata <sup>(2)</sup>		
C2	C1608X7R1E104K	TDK	0.1µF Ceramic Capacitor, 25V, X7R, Size 0603	1
	06033C104KAT2A	AVX <sup>(3)</sup>		
	GRM188R71E104KA01D	Murata		
C3	B41851-A9107-M008	TDK	100µF, 100V, Radial Electrolytic Capacitor	1
C4	CGA5L2X7R2A105K	TDK	1.0µF Ceramic Capacitor, 100V, X7R, Size 1206	1
	12061C105K4Z4A	AVX		
	GRF31CR72A105KA01L	Murata		
Q1, Q3	AM7414NA	Analog Power <sup>(4)</sup>	100V , N-Channel MOSFET , SO8	2
	SiR698DP-T1-GE3	Vishay		
U1	MIC4605YM	Micrel, Inc. <sup>(5)</sup>	85V Half-Bridge MOSFET Drivers with 5.5V to 16V Gate Drive	1

### Notes:

1. TDK: [www.tdk.com](http://www.tdk.com).
2. Murata: [www.murata.com](http://www.murata.com).
3. AVX: [www.avx.com](http://www.avx.com).
4. Analog Power: [www.analogpowerinc.com](http://www.analogpowerinc.com).
5. Micrel, Inc.: [www.micrel.com](http://www.micrel.com).

## PCB Layout Recommendations (MIC4605YM)

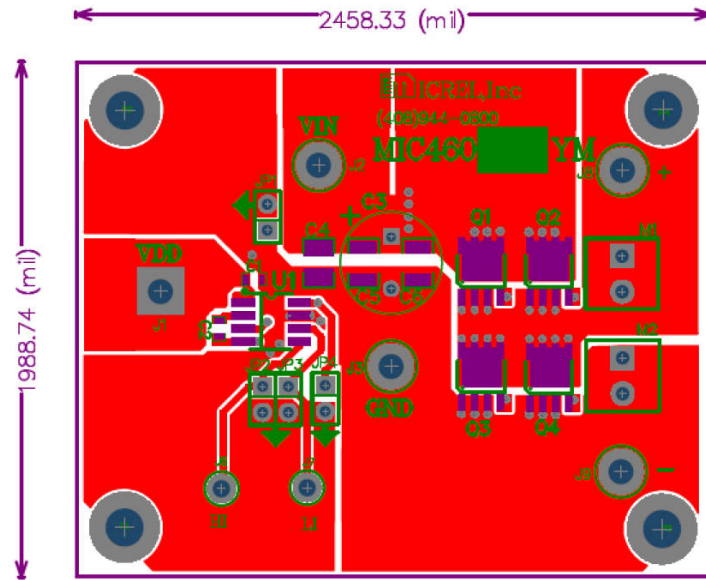

MIC4605YM Evaluation Board – Top Layer

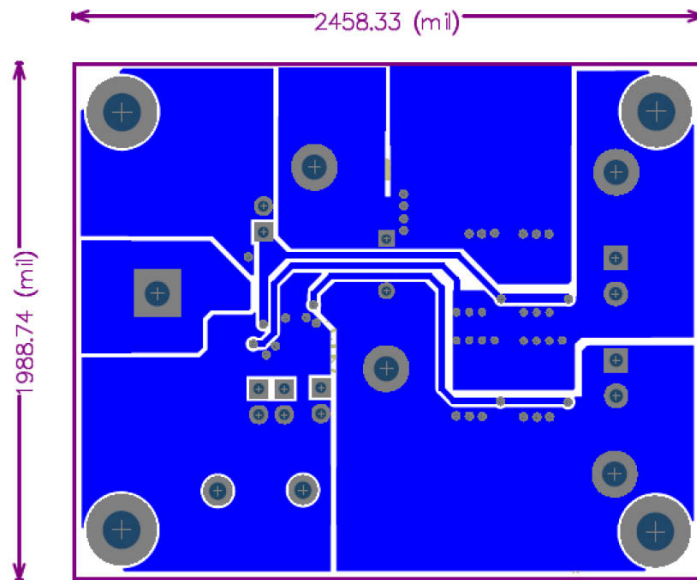

MIC4605YM Evaluation Board – Bottom Layer

## Evaluation Board Schematic (MIC4605YMT)

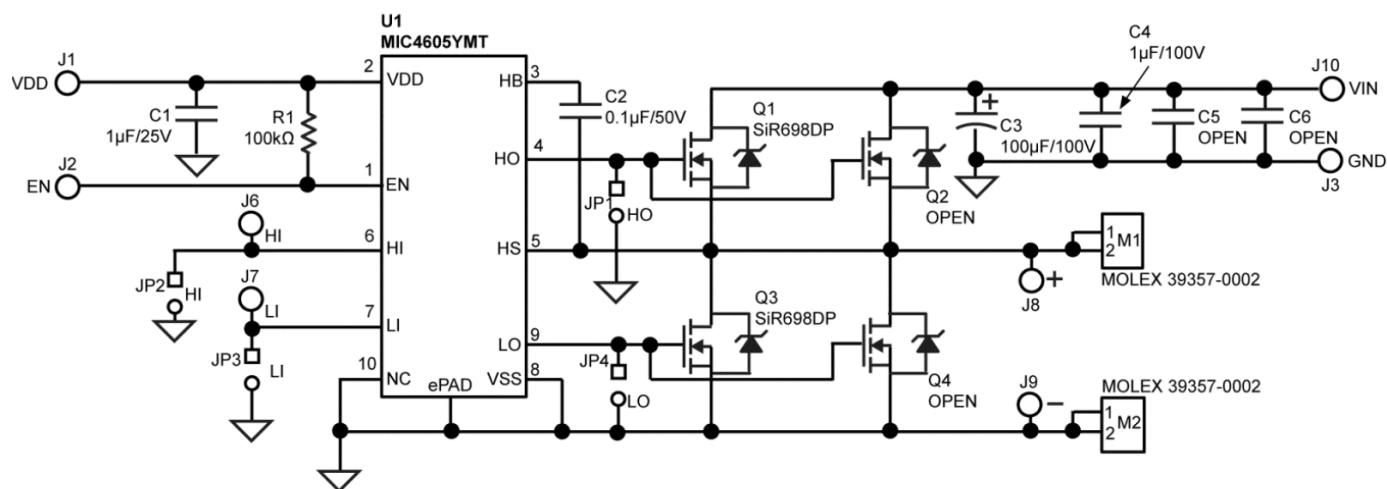

## Bill of Materials

Item	Part Number	Manufacturer	Description	Qty.
C1	C1608X7R1E105K	TDK <sup>(6)</sup>	1.0µF Ceramic Capacitor, 25V, X7R, Size 0603	1
	GRM188R71E105KA12D	Murata <sup>(7)</sup>		
C2	C1608X7R1E104K	TDK	0.1µF Ceramic Capacitor, 25V, X7R, Size 0603	1
	06033C104KAT2A	AVX <sup>(8)</sup>		
	GRM188R71E104KA01D	Murata		
C3	B41851-A9107-M008	TDK	100µF, 100V, Radial Electrolytic Capacitor	1
C4	CGA5L2X7R2A105K	TDK	1.0µF Ceramic Capacitor, 100V, X7R, Size 1206	1
	12061C105K4Z4A	AVX		
	GRF31CR72A105KA01L	Murata		
Q1, Q3	AM7414NA	Analog Power <sup>(9)</sup>	100V , N-Channel MOSFET , SO8	2
	SiR698DP-T1-GE3	Vishay		
U1	MIC4605YMT	Micrel, Inc. <sup>(10)</sup>	85V Half-Bridge MOSFET Drivers with 5.5V to 16V Gate Drive	1

### Notes:

6. TDK: [www.tdk.com](http://www.tdk.com).
7. Murata: [www.murata.com](http://www.murata.com).
8. AVX: [www.avx.com](http://www.avx.com).
9. Analog Power: [www.analogpowerinc.com](http://www.analogpowerinc.com).
10. Micrel, Inc.: [www.micrel.com](http://www.micrel.com).

## PCB Layout Recommendations (MIC4605YMT)

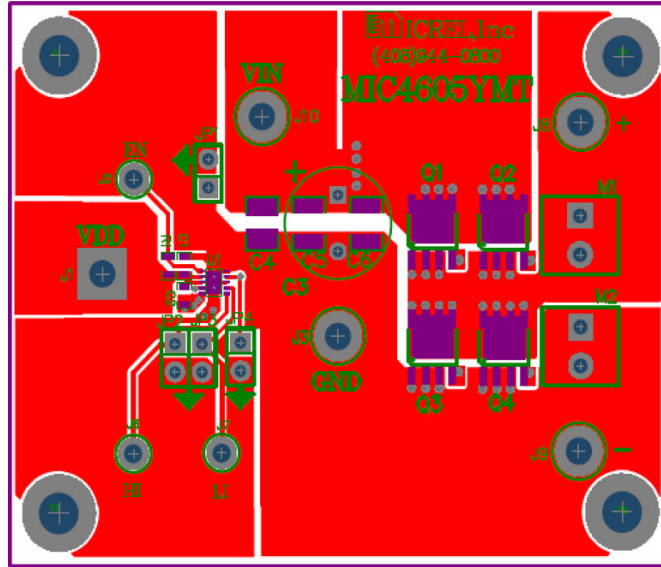

MIC4605YMT Evaluation Board – Top Layer

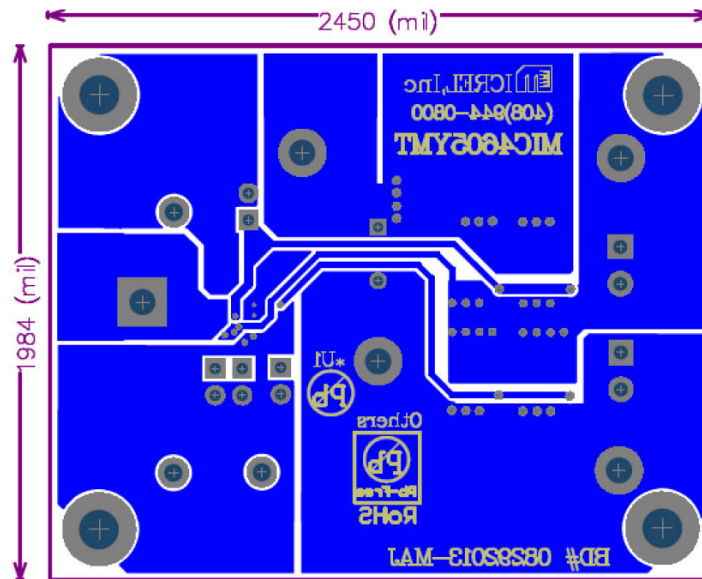

MIC4605YMT Evaluation Board – Bottom Layer

---

**MICREL, INC. 2180 FORTUNE DRIVE SAN JOSE, CA 95131 USA**  
TEL +1 (408) 944-0800 FAX +1 (408) 474-1000 WEB <http://www.micrel.com>

Micrel makes no representations or warranties with respect to the accuracy or completeness of the information furnished in this data sheet. This information is not intended as a warranty and Micrel does not assume responsibility for its use. Micrel reserves the right to change circuitry, specifications and descriptions at any time without notice. No license, whether express, implied, arising by estoppel or otherwise, to any intellectual property rights is granted by this document. Except as provided in Micrel's terms and conditions of sale for such products, Micrel assumes no liability whatsoever, and Micrel disclaims any express or implied warranty relating to the sale and/or use of Micrel products including liability or warranties relating to fitness for a particular purpose, merchantability, or infringement of any patent, copyright or other intellectual property right.

Micrel Products are not designed or authorized for use as components in life support appliances, devices or systems where malfunction of a product can reasonably be expected to result in personal injury. Life support devices or systems are devices or systems that (a) are intended for surgical implant into the body or (b) support or sustain life, and whose failure to perform can be reasonably expected to result in a significant injury to the user. A Purchaser's use or sale of Micrel Products for use in life support appliances, devices or systems is a Purchaser's own risk and Purchaser agrees to fully indemnify Micrel for any damages resulting from such use or sale.

© 2013 Micrel, Incorporated.

# Mouser Electronics

Authorized Distributor

Click to View Pricing, Inventory, Delivery & Lifecycle Information:

[Micrel:](#)

[MIC4605-2YM EV](#) [MIC4605-1YM EV](#) [MIC4605-1YM-EV](#) [MIC4605-1YMT-EV](#) [MIC4605-2YMT-EV](#) [MIC4605-2YM-EV](#)



Компания «Океан Электроники» предлагает заключение долгосрочных отношений при поставках импортных электронных компонентов на взаимовыгодных условиях!

Наши преимущества:

- Поставка оригинальных импортных электронных компонентов напрямую с производств Америки, Европы и Азии, а так же с крупнейших складов мира;
- Широкая линейка поставок активных и пассивных импортных электронных компонентов (более 30 млн. наименований);
- Поставка сложных, дефицитных, либо снятых с производства позиций;
- Оперативные сроки поставки под заказ (от 5 рабочих дней);
- Экспресс доставка в любую точку России;
- Помощь Конструкторского Отдела и консультации квалифицированных инженеров;
- Техническая поддержка проекта, помощь в подборе аналогов, поставка прототипов;
- Поставка электронных компонентов под контролем ВП;
- Система менеджмента качества сертифицирована по Международному стандарту ISO 9001;
- При необходимости вся продукция военного и аэрокосмического назначения проходит испытания и сертификацию в лаборатории (по согласованию с заказчиком);
- Поставка специализированных компонентов военного и аэрокосмического уровня качества (Xilinx, Altera, Analog Devices, Intersil, Interpoint, Microsemi, Actel, Aeroflex, Peregrine, VPT, Syfer, Eurofarad, Texas Instruments, MS Kennedy, Miteq, Cobham, E2V, MA-COM, Hittite, Mini-Circuits, General Dynamics и др.);

Компания «Океан Электроники» является официальным дистрибьютором и эксклюзивным представителем в России одного из крупнейших производителей разъемов военного и аэрокосмического назначения «JONHON», а так же официальным дистрибьютором и эксклюзивным представителем в России производителя высокотехнологичных и надежных решений для передачи СВЧ сигналов «FORSTAR».



## JONHON

«JONHON» (основан в 1970 г.)

Разъемы специального, военного и аэрокосмического назначения:

(Применяются в военной, авиационной, аэрокосмической, морской, железнодорожной, горно- и нефтедобывающей отраслях промышленности)

«FORSTAR» (основан в 1998 г.)

ВЧ соединители, коаксиальные кабели, кабельные сборки и микроволновые компоненты:

(Применяются в телекоммуникациях гражданского и специального назначения, в средствах связи, РЛС, а так же военной, авиационной и аэрокосмической отраслях промышленности).



Телефон: 8 (812) 309-75-97 (многоканальный)

Факс: 8 (812) 320-03-32

Электронная почта: [ocean@oceanchips.ru](mailto:ocean@oceanchips.ru)

Web: <http://oceanchips.ru/>

Адрес: 198099, г. Санкт-Петербург, ул. Калинина, д. 2, корп. 4, лит. А