

EMOSAFE EN-60KDS

Product Datasheet

Keystone Network Isolator with Cable

December 2015

1 FEATURES AND ADVANTAGES

- Compact Keystone module with cable
- 6 kV AC dielectric strength
- 8.5 kV DC dielectric strength
- Suitable for wall mounting and appliance integration
- Suitable for use within medical supply units
- Designed and tested to meet the third edition of IEC 60601-1
- UL Recognized Component
- Gigabit Ethernet
- ISO 11801 Class D Ethernet Performance attainable in Permanent Link
- Extremely low insertion loss, allowing total cabling distances to reach 100 m
- 100% quality control testing
- Available in various cable stub lengths
- Additional transient voltage suppression on signal lines
- Suitable for devices with supply voltages up to 400 V AC
- RoHS conformant



2 GENERAL DESCRIPTION

The EMOSAFE EN-60 Network Isolator disconnects every electrically conducting connection (specifically the data and shield conductors) between devices connected together via a copper-based Ethernet network. The Network Isolator prevents current flow resulting from differences in electrical potentials, and also protects connected devices and their users from stray external voltages and power surges which may be directly or inductively coupled onto the network lines by causes such as installation errors, lightning, switching operations, and electrostatic discharge.

Built into a medical electrical (ME) product, the EMOSAFE EN-60 Network Isolator facilitates the safe Ethernet connection of this ME product within the patient environment. The EN-60 satisfies all construction requirements of IEC 60601-1 (3rd Edition) in the formation of two means of patient protection (MOPP) within the network interface, thereby practically eliminating the risk of electrical shocks arising from such stray external voltages at the network connection. With its UL approval, the EN-60 is also suitable for devices destined for export to the North American markets.

The EMOSAFE EN-60KDS is an efficient and compact gigabit Ethernet network isolator, characterised by exceptional Ethernet performance and a very high dielectric withstanding voltage. As a Keystone module, it can be used in all Keystone-compatible outlet sockets, patch panels, and panel cut-outs. The construction with socket and cable stub provides the physical functionality of an extension cable.

The EN-60KDS is further complemented by additional electrostatic discharge (ESD) and lightning strike protection. Normal network isolators do not suppress voltage spikes within individual signal lines. The EN-60KDS eliminates these spikes by means of a supplementary transient voltage suppression (TVS) diode circuit. This is particularly effective against the effects of electrostatic discharge, which can, for example, occur as cables are connected and removed.

Low-frequency signal components are strongly attenuated, protecting connected devices from ground loops.

The EMOSAFE EN-60KDS Network Isolator transmits high-frequency signals through the principle of electro-magnetic induction. This results in the EN-60KDS not requiring any external power supply. There are no software drivers to be installed.

3 APPLICATIONS

3.1 PATIENT PROTECTION

Electrical separation of Ethernet interfaces of medical electrical (ME) devices and systems, where patients must be protected from dangerous leakage currents, in conformity with applicable standards.

3.2 EQUIPMENT PROTECTION

Applications, in which valuable devices or those requiring special protection need to be protected against ripple, mains hum, and surge voltages from the network periphery.

3.3 MEASUREMENT TECHNOLOGY

Electrical measuring and monitoring equipment, which needs to be protected against external and interference voltages arising from the Ethernet periphery.

3.4 POTENTIAL DIFFERENCES (TECHNICAL BUILDING SYSTEMS)

Computer systems, which are electrically connected with each other over significant distances via Ethernet cabling, where current flows caused by potential differences must be prevented.

3.5 AUDIO

Audio applications, in which the transmission of low frequency alternating current voltages (mains hum) over the network connection is to be reduced to an imperceptible level.

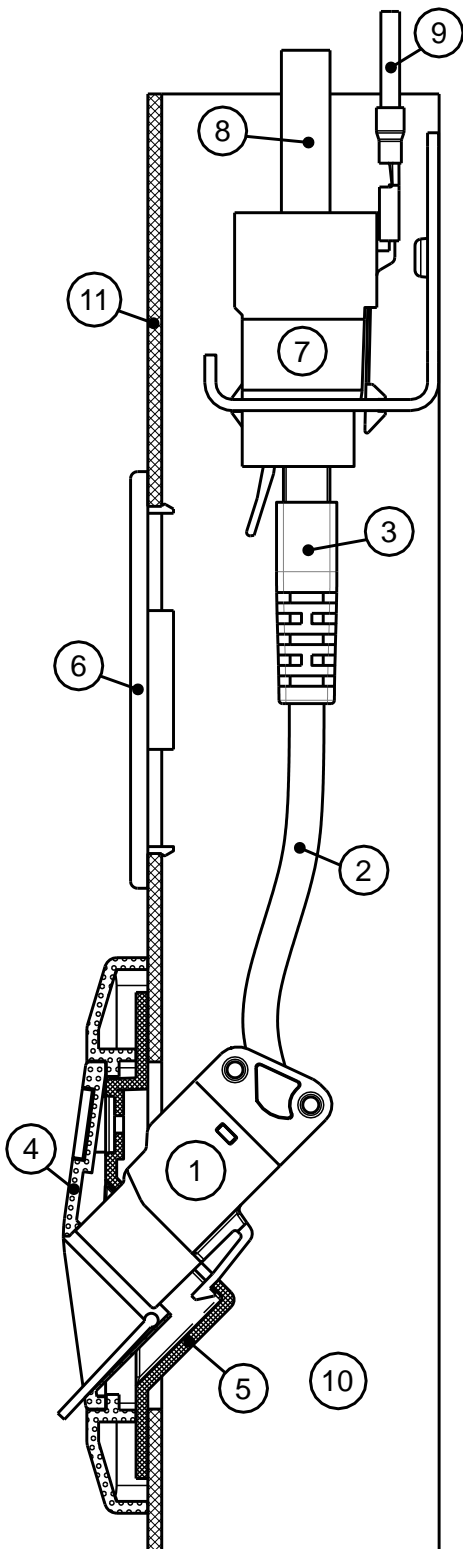

Figure 1. EN-60 assembly within a cable duct

All dimensions in mm.

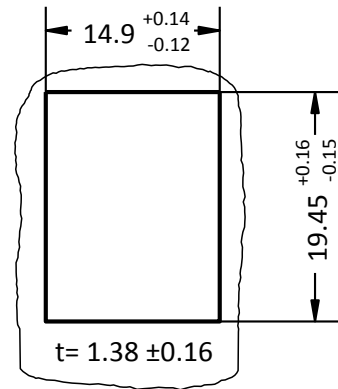

Figure 2. Suggested Keystone Cut-out

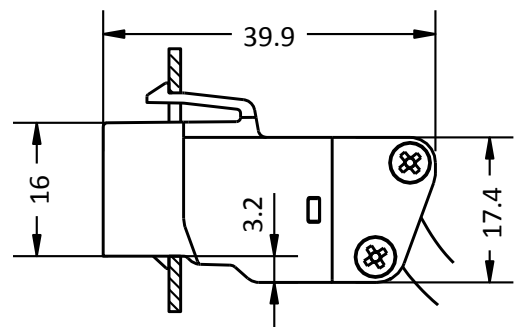

Figure 3. Physical dimensions

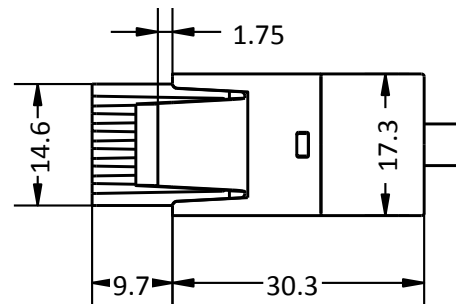

Figure 4. Physical dimensions

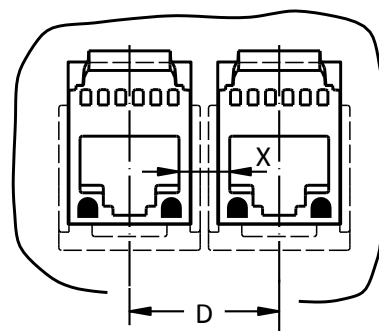

Figure 5. Installation in multiple module carriers

5 SAFETY NOTICE

When required for compliance with IEC 60601-1, it is essential that the creepage and clearance distances are observed during assembly. The isolating effect of the Network Isolator must not be compromised by neighbouring conductive components. If, for example, the installation of the Network Isolator is to be within a metal plate, this plate must be grounded as a protective earth (PE) connection.

The EN-60KDS Network Isolator should, in principle, terminate a permanent cable installation. A set-back instalment e.g. within the cable duct, or installation in a remote patch panel, is not recommended, since the protective properties of the Network Isolator are only guaranteed directly at its own RJ45 socket.

6 INSTALLATION

The Network Isolator EN-60KDS can be snapped into any housing aperture which corresponds to the Keystone dimension requirements shown in Figure 2.

6.1 GENERAL

Network isolators are designed for data transmission in the frequency range of 300 kHz to 100 MHz. Lower frequencies are strongly attenuated. For this reason, it is generally not possible to transmit the signals of nurse call systems, telephone systems, analogue audio or video signals over a network isolator.

The EN-60KDS Network Isolator can be used in a Power over Ethernet (PoE) network without restriction; however due to the electrical isolation, PoE devices will not be supplied with power.

6.2 INSTALLATION WITHIN CABLE CHANNELS AND MEDICAL SUPPLY UNITS

Figure 1 shows a typical assembly within a cable duct (10), with cover (11). The Network Isolator EN-60KDS (1) is shown installed in a Keystone-compatible wall outlet, which usually consists of a support frame (5) and a plastic front panel (4). The RJ45 plug (3) of the Network Isolator is to be inserted into a RJ45 jack module termination (7) at the end of the permanently installed data cable (8). When retrofitting the Network Isolator EN 60KDS (1) into network channels, the existing RJ45 jack module from the wall outlet can be shifted back within the cable duct (10), and used as the connection to the Network Isolator.

The interface at the RJ45 jack module (7) between the permanently installed cable and the Network Isolator must be kept accessible if regular safety checks are to be conducted, or if the ability to subsequently verify the permanent installation is required. If this is not already made possible by a removable duct cover (11), we recommend the installation of a service access panel (6).

The EN-60KDS Network Isolator also interrupts the shield connection. Should the cable shield of the permanently installed network cable (8) need to be connected with the room or equipment potential, this must occur at the shifted-back RJ45 jack module (7), i.e. with the help of an earthing wire (9).

Permanent tensile loading on the connecting cable (2) is not permitted. Additionally, refer to section 9 *SPECIFICATIONS* regarding the minimum bend radius of the cable.

If it is intended that two or more EN-60KDS Network Isolators will be installed side by side into multiple module carriers, the mounting distance "D" in Figure 5 must be taken into account. Crucial to this is the creepage distance across the dimension "X" in Figure 5, between the shield plates of the inserted RJ45 plugs. The resulting creepage distance must not fall short of 8 mm (250 V AC), or 12 mm (400 V AC), as appropriate for the voltage scenario. The centre-to-centre distance "D" can however be reduced, if the

creepage distance across the dimension "X" is increased accordingly (e.g. by adding plastic dividers). Combining EN-60KDS Network Isolators and non-galvanically isolated Keystone modules within module carriers is not recommended.

6.3 QUALITY REQUIREMENTS ON CABLE INSTALLATIONS

In order for a cabling path in which an EN-60KDS Network Isolator is installed to meet the Permanent Link requirements of Class D or Cat.5e, the cable installation (without the Network Isolator) must provide a performance reserve. The following performance reserves (clearances from the margins) to the Class D or Cat.5e margins must be met or exceeded when measuring the cable installation without the Network Isolator:

NEXT:	4.0 dB
Return Loss:	4.0 dB
Insertion Loss:	1.5 dB + 0.3 dB/m

The Insertion Loss (IL) reserve is to be calculated for the length of the chosen EN-60KDS Network Isolator. Example: an EN-60KDS with a 2 m cable length results in an IL reserve of: $1.5 \text{ dB} + 2 \text{ m} \times 0.3 \text{ dB/m} = 2.1 \text{ dB}$

6.4 INSTALLATION WITHIN DEVICES

When building an EN-60KDS into a device, it is important during manufacturing to observe that the resulting creepage and clearance distances of the mounting frame are maintained in accordance with relevant standards.

7 SAFETY AND FUNCTION TESTING

7.1 FUNCTION AND COMPLIANCE TESTING

The transmission properties of permanent network installations fitted with EN-60KDS Network Isolators can be checked with cable certification devices which are suitable for testing electrically isolated cable sections. To be able to conduct such an inspection, the test equipment must be configured in an AC wire-map mode. The entire cable route, including the Network Isolator, can be tested to EIA/TIA-568 Cat.5e or ISO 11801 Class D. Testing of the cable shielding and the conductor resistance is not possible in this mode. If however, these tests are required, or if the quality of the cable route itself needs to be tested (without the Network Isolator), then testing can be performed by bypassing the Network Isolator, and connecting directly to the RJ45 socket (7), set back within the cable duct, as indicated in Figure 1.

7.2 SAFETY INSPECTIONS

Regular safety inspections and post-repair inspections are not prescribed for network isolators in medical use, as network isolators themselves are not classified as medical electrical (ME) devices. However, together with a connected medical device, network isolators form an ME system, which altogether may be subject to inspection. The test interval, as well as the requirements to be met for both regular safety inspections and post-repair inspections will be specified by the responsible organisation (as defined in IEC 60601-1), and based upon the applicable standards for the entire ME system.

To simplify implementation, the system components (in this case, the network isolator) can be individually tested. The responsible organisation provides the test parameters and test interval. Such an assessment may, depending upon requirements, include the following checks:

7.2.1 VISUAL INSPECTION

Check for evidence of external damage and ingress of substances; dust or liquids for example.

7.2.2 LEAKAGE CURRENT TEST

It is to be checked if the measured leakage current is still within the prescribed limits. For this purpose, test equipment which can perform equipment leakage current measurements in accordance with IEC 62353 may be used. To perform a leakage current test, all conductors on the input side must be short-circuited together, and all the conductors on the output side must also be short-circuited together. The AC test voltage specified by the responsible organisation is then applied across these two connections. Input and output sides are interchangeable. The expected current flow can be found in section *9 SPECIFICATIONS*.

7.2.3 HIPOT TEST

To ensure that the device under test is not damaged, it is recommended that a DC voltage source is used in place of the AC voltage source, and that the DC voltage is 1½ times that of the required AC voltage. The test setup is essentially the same as that of the Leakage Current Test above. The expected dielectric strength can be found in section *9 SPECIFICATIONS*.

7.2.4 FUNCTIONAL TEST

After conducting the tests above, and reconnecting the Network Isolator into the network, it is meaningful to examine whether the signal transmission is still performing correctly. Such a functional test can be performed, for example, with a suitable Ethernet cable certification device. Refer to the section *7.1 FUNCTION AND COMPLIANCE TESTING*.

8 MODEL OPTIONS AND ORDERING INFORMATION

8.1 NOTES

The length of the flexible cable stub (2) (see Figure 1 in section 4) of the EN-60KDS Network Isolator is available in selected lengths from 30 mm to 10 m (inclusive). Refer to Figure 6 in section 8.2, as well as the table in section 8.3. It is recommended that this length be kept to a minimum. When compared to a fixed installed cable, this flexible cable stub may be more susceptible to near end crosstalk (NEXT) and alien crosstalk (AXT). The flexible cable stub itself generates a small, but length-dependent amount of insertion loss (IL).

Refer to section *6.3 QUALITY REQUIREMENTS ON CABLE INSTALLATIONS*.

For flexible cable stub lengths between 30 mm and 500 mm (inclusive), the plug angle can be chosen, easing mechanical constraints in certain assembly configurations, and removing impermissible torsion strains from the cable assembly. Refer to Figure 6 in section *8.2 TECHNICAL DRAWINGS*. The manufacturing tolerance for the plug angle is $\pm 20^\circ$.

8.2 TECHNICAL DRAWINGS

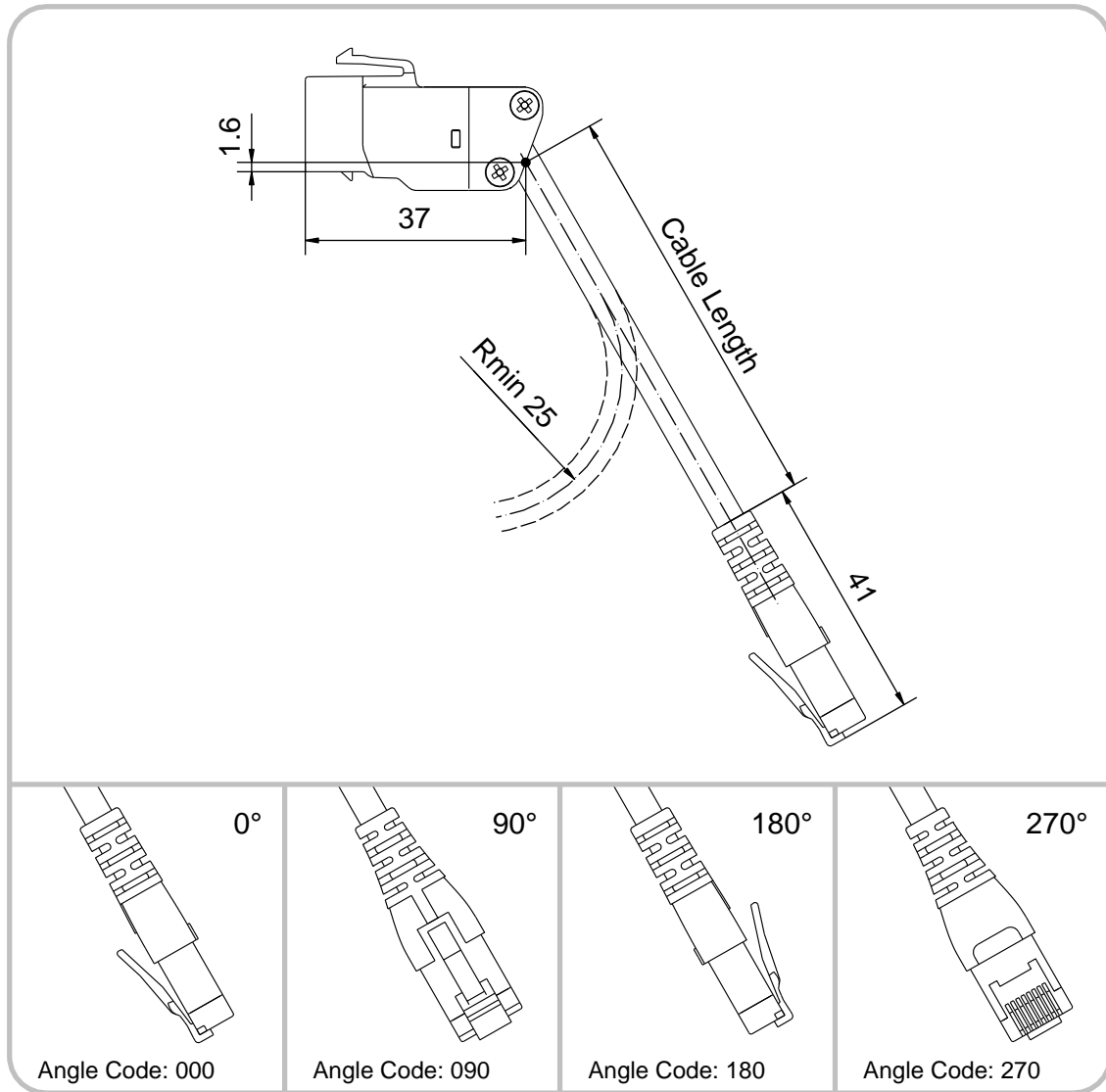

Figure 6. Technical drawing for EN-60, showing definition of cable length, as well as angle codes. All dimensions in mm.

8.3 AVAILABLE CABLE LENGTHS

Length Groups	Step	Length Tolerance	Length Code
30, 40, ... 100 mm	10 mm	± 5 mm	00030 ... 00100
120, 140, ... 300 mm	20 mm	± 7 mm	00120 ... 00300
350, 400, ... 1000 mm	50 mm	± 15 mm	00350 ... 01000
1100, 1200, ... 3000 mm	100 mm	± 30 mm	01100 ... 03000
3500, 4000, ... 10000 mm	500 mm	± 50 mm	03500 ... 10000

8.4 ORDER NUMBERS

When placing orders for EN-60KDS, please specify the exact order number. The order number is a hyphenated concatenation of the Article Number (A10043), the Length Code for the desired cable length (see section 8.3), and the Angle Code for the desired plug angle (see Figure 6 in section 8.2). For flexible cable stub lengths greater than 500 mm, the EN-60KDS will always be manufactured with a plug angle of 0°, and the Angle Code can be omitted for such orders.

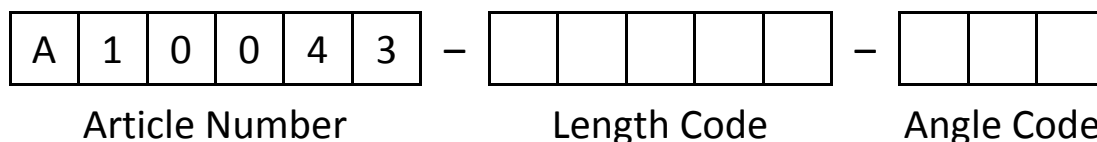

9 SPECIFICATIONS

9.1 GENERAL

Category	Standards or Test Criteria	Properties
Designation		EMOSAFE EN-60KDS
Housing Colour		White
Housing Material		Plastic
Construction		Keystone Module with Cable
Cable Length	See Figure 6	Selected lengths between 30 mm and 10 m (inclusive)
Minimum Bending Radius		25 mm
Input Interface		RJ45 Jack, straight
Output Interface		RJ45 Plug, cable
Weight	with 200 mm cable length	approximately 22 g
Protection Rating	EN 60529	IP40
Mating Cycles:	Correct: RJ45 plug in RJ45 socket	> 1000 cycles
	Mismatched: with RJ11 / RJ12 / RJ25	maximum of 100 cycles
Mean Time To Failure (MTTF)	SN 29500 Standard Temperature: 25°C Duty cycle: 100% (24 hours, 7 days)	3,230 years
	SN 29500 Standard Temperature: 40°C Duty cycle: 100% (24 hours, 7 days)	3,060 years

9.2 ETHERNET PERFORMANCE

Category	Standards or Test Criteria	EN-60KDS
Transmission Speeds and Supported Network Protocols	10 Mbit/s, 10Base-T (IEEE802.3 Cl.14)	✓
	100 Mbit/s, 100Base-Tx (IEEE802.3 Cl.25)	✓
	1000 Mbit/s, 1000Base-T (IEEE802.3 Cl.40)	✓
Performance Category	ISO 11801, Permanent Link (PL)	Class D
Insertion Loss (absolute)	Typical:	0.7 dB * @ 100 MHz
	Maximum:	1.0 dB * @ 100 MHz
Return Loss (absolute)	Typical:	17.0 dB @ 100 MHz
	Minimum:	14.0 dB @ 100 MHz

9.3 ELECTRICAL

Category	Standards or Test Criteria	EN-60KDS
AC Dielectric Strength	at 50 Hz, for 60 seconds	6.0 kV
DC Dielectric Strength	for 60 seconds	8.5 kV
Reinforced Isolation	IEC 60601-1	✓
Coupling Capacitance per Channel		37.5 pF ±25%
Total Coupling Capacitance		150 pF ±25%
Total Leakage Current	275 V AC at 50 Hz	Typical: 12.0 µA
		Maximum: 16.0 µA
TVS diode circuitry	Suppression of transients on the signal lines	✓

* Valid for EN-60 Network Isolators with a cable length of 200 mm. For other lengths, maximum is 0.9 dB + (0.3 dB/m × length).

9.4 OPERATING CONDITIONS AND AREA OF APPLICATION

Category	Standards or Test Criteria	EN-60KDS	
Pollution Degree	IEC 61010	2 *	
Overvoltage Category	IEC 60664-1	III	
Maximum Working Voltage †	Maximum mains voltage of the connected devices, in accordance with IEC 60601-1	400 V AC 450 V DC	
Temperature		Minimum:	+10°C
		Maximum:	+60°C
Air Humidity	Non-condensing	Minimum:	10%
		Maximum:	90%
Air Pressure		Minimum:	700 hPa
		Maximum:	1,060 hPa
Altitude		Maximum:	3,200 m

9.5 ENVIRONMENTAL CONDITIONS: STORAGE AND TRANSPORTATION

Category	Standards or Test Criteria	EN-60KDS	
Temperature		Minimum:	-10°C
		Maximum:	+75°C
Air Humidity	Non-condensing	Minimum:	10%
		Maximum:	90%
Air Pressure		Minimum:	500 hPa
		Maximum:	1,060 hPa

9.6 CERTIFICATES

All Network Isolators from EMO Systems GmbH are additionally registered by UL International as Recognized Components, under the file numbers E249126 and E362969. They are therefore suitable for application in American and Canadian markets.

Furthermore, the compliance of our Network Isolators with the standard specifications IEC 60601-1 (3rd Ed.), ANSI/AAMI ES60601-1 and CAN/CSA-C22.2 No. 60601-1 has been confirmed by an independent, accredited laboratory. To view a copy of these certificates, please visit the [UL Online Directory](#) or contact us directly.

The certification of our products to the requirements of the IEC 60601-1-2 has also been confirmed by an external laboratory. The test report can be obtained upon request.

Our Declaration of Conformity can be found on our website, which confirms the compliance of our products with the requirements of the Low Voltage Directive, the Electromagnetic Compatibility Directive, and the Restriction of Hazardous Substances Directive (RoHS).

* Normally only nonconductive pollution occurs. Temporary conductivity caused by condensation is to be expected.

† The Network Isolator can be permanently exposed to this voltage level.

Category	Standards or Test Criteria	EN-60KDS
UL Recognized Component		✓
UL File No.		E246126 E362969
IEC 60601-1	Complies with the requirements of a galvanic separator in accordance with IEC 60601-1 (Ed. 3.1)	✓
IEC 60601-1-2	Complies with the requirements of IEC 60601-1-2	✓
ANSI/AAMI ES 60601-1	Complies with the requirements of ANSI/AAMI ES60601-1	✓
CAN/CSA-C22.2 No. 60601-1	Complies with the requirements of CAN/CSA-C22.2 No. 60601-1	✓
Low Voltage Directive	Complies with the requirements of the directive 2014/35/EU	✓
EMC Directive	Complies with the requirements of the directive 2004/108/EU	✓
RoHS Directive	Complies with the requirements of the directive 2011/65/EU	✓
Lead-free	Contains no lead-containing substances, and is manufactured with lead-free solder	✓

9.7 ISOLATION DIAGRAM

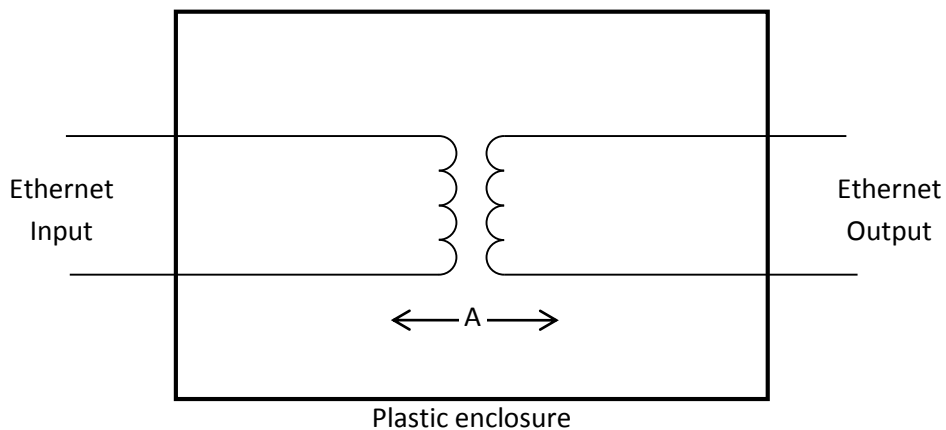

Figure 7. Isolation diagram for EN-60KDS

Area	Number and type of Means of Protection	Material Group (from CTI)	Maximum Operating Voltage		Required creepage distance (mm)	Required clearance distance (mm)	Measured creepage distance (mm)	Measured clearance distance (mm)
			V AC	V _{peak}				
A	2 MOPP *	IIIb †	400	565	12.0	7.0	12.0	9.0

* MOPP = Means of Patient Protection

† Materials in the Material Group IIIb have a Comparative Tracking Index (CTI) value between 100 and 175.

9.8 FREQUENCY RESPONSE

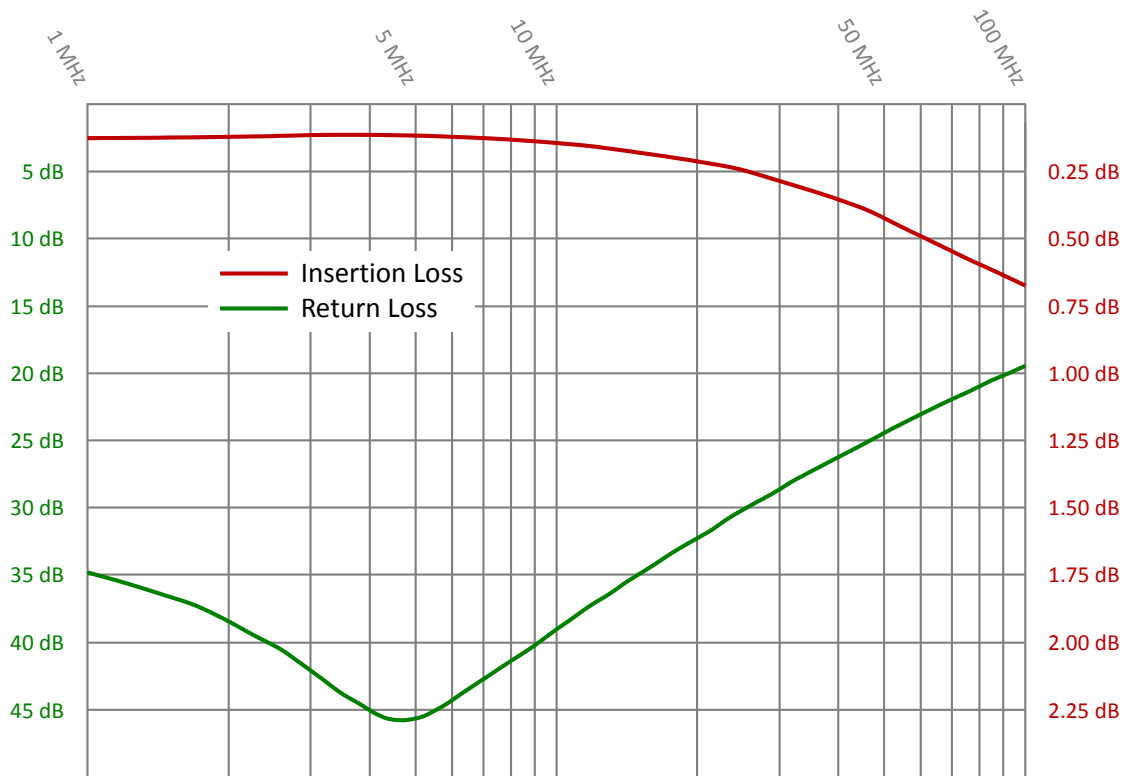

Figure 8. Typical frequency response for EN-60KDS with a 200 mm cable stub length

10 SCHEMATIC DIAGRAM

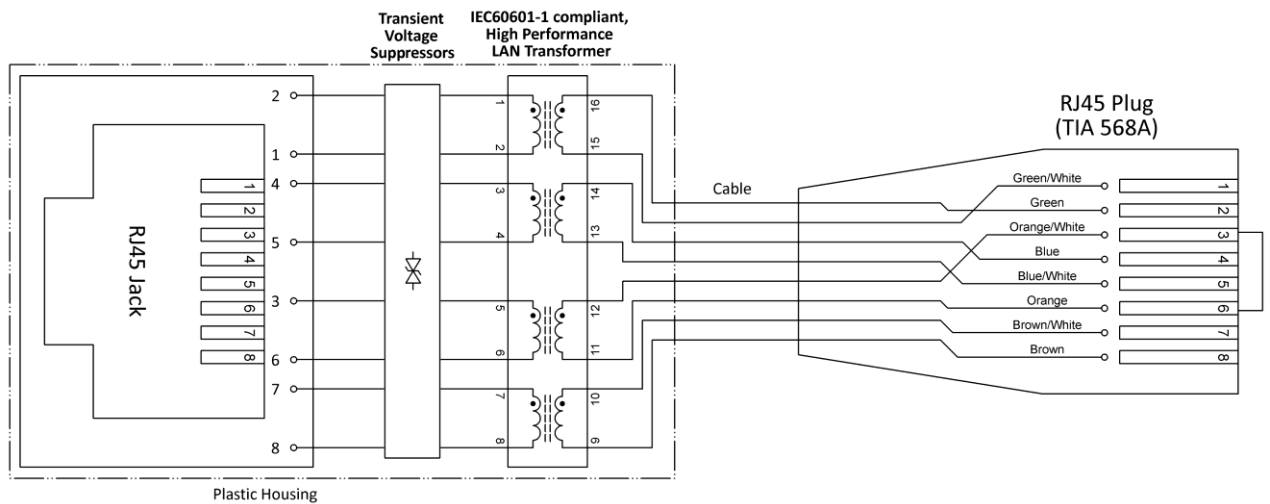

Figure 9. Schematic diagram of the EN-60KDS

11 PACKAGING





Contents:

- EN-60KDS
- Installation Guide

A packaging label provides the following information:

- Article Description
- Quantity
- Cable Length
- Plug Angle
- Order Code (OC)
- Date of Manufacture
- Serial Number (SN)
- The Serial Number is printed as both a linear (Code 128) and a 2-D Barcode (Data Matrix)

12 PRODUCT MARKINGS

	<p>Through this mark, the conformity of the product with all applicable EU Directives is confirmed.</p>
	<p>Designates the product as a UL "Recognised Component"; File number E249126.</p>
	<p>The product may not be disposed of in domestic rubbish.</p>
	<p>This product contains no substances containing lead and is manufactured using lead-free solder.</p>
	<p>This product meets the requirements of EU Directive concerning the limitation of the use of certain hazardous substances in electric and electronic equipment.</p>

13 SCHEDULED MAINTENANCE

When used as directed, EMOSAFE Network Isolators are maintenance-free.

14 ENVIRONMENTAL PROTECTION INFORMATION

This device contains electronic components. At the end of its service life it is to be returned to the manufacturer for disposal.

15 QUALITY

EMO Systems operates a certified quality management system for development and production in accordance with ISO 9001 and ISO 13485. Prior to delivery, each Network Isolator is subjected to a comprehensive quality inspection. This inspection ensures, among other factors, that the attained values for leakage currents, dielectric withstand strengths, insertion losses, return losses, and near end crosstalk values all meet the specified requirements.

16 ACCESSORIES

There are currently no accessories available for the EN-60KDS.

17 CONTACT AND SUPPORT

Please find our up-to-date contact details on our website: <http://www.emosystems.de/en/contact>

Or send us an e-mail at the following address: support@emosystems.de

18 LEGAL NOTIFICATION

The information provided above in this datasheet has been compiled with all due care, and is believed to be accurate and reliable. However, we cannot guarantee that the information contained is completely free from error.

The end user is responsible and liable for the proper use of this product; EMO Systems assume no liability. We reserve the right to make changes to this datasheet without notice.

Компания «Океан Электроники» предлагает заключение долгосрочных отношений при поставках импортных электронных компонентов на взаимовыгодных условиях!

Наши преимущества:

- Поставка оригинальных импортных электронных компонентов напрямую с производств Америки, Европы и Азии, а так же с крупнейших складов мира;
- Широкая линейка поставок активных и пассивных импортных электронных компонентов (более 30 млн. наименований);
- Поставка сложных, дефицитных, либо снятых с производства позиций;
- Оперативные сроки поставки под заказ (от 5 рабочих дней);
- Экспресс доставка в любую точку России;
- Помощь Конструкторского Отдела и консультации квалифицированных инженеров;
- Техническая поддержка проекта, помощь в подборе аналогов, поставка прототипов;
- Поставка электронных компонентов под контролем ВП;
- Система менеджмента качества сертифицирована по Международному стандарту ISO 9001;
- При необходимости вся продукция военного и аэрокосмического назначения проходит испытания и сертификацию в лаборатории (по согласованию с заказчиком);
- Поставка специализированных компонентов военного и аэрокосмического уровня качества (Xilinx, Altera, Analog Devices, Intersil, Interpoint, Microsemi, Actel, Aeroflex, Peregrine, VPT, Syfer, Eurofarad, Texas Instruments, MS Kennedy, Miteq, Cobham, E2V, MA-COM, Hittite, Mini-Circuits, General Dynamics и др.);

Компания «Океан Электроники» является официальным дистрибьютором и эксклюзивным представителем в России одного из крупнейших производителей разъемов военного и аэрокосмического назначения «JONHON», а так же официальным дистрибьютором и эксклюзивным представителем в России производителя высокотехнологичных и надежных решений для передачи СВЧ сигналов «FORSTAR».



JONHON

«JONHON» (основан в 1970 г.)

Разъемы специального, военного и аэрокосмического назначения:

(Применяются в военной, авиационной, аэрокосмической, морской, железнодорожной, горно- и нефтедобывающей отраслях промышленности)

«FORSTAR» (основан в 1998 г.)

ВЧ соединители, коаксиальные кабели, кабельные сборки и микроволновые компоненты:

(Применяются в телекоммуникациях гражданского и специального назначения, в средствах связи, РЛС, а так же военной, авиационной и аэрокосмической отраслях промышленности).



Телефон: 8 (812) 309-75-97 (многоканальный)

Факс: 8 (812) 320-03-32

Электронная почта: ocean@oceanchips.ru

Web: <http://oceanchips.ru/>

Адрес: 198099, г. Санкт-Петербург, ул. Калинина, д. 2, корп. 4, лит. А