

## 1.5A Dual Open-Drain MOSFET Drivers

### Features:

- Independently Programmable Rise and Fall Times
- Low Output Impedance – 7Ω Typ.
- High Speed  $t_R$ ,  $t_F$  – <30 nsec with 1000 pF Load
- Short Delay Times – <30 nsec
- Wide Operating Range:
  - 4.5V to 18V
- Latch-Up Protected: Will Withstand > 500 mA Reverse Current (Either Polarity)
- Input Withstands Negative Swings Up to -5V

### Applications:

- Motor Controls
- Driving Bipolar Transistors
- Driver for Non-overlapping Totem Poles
- Reach-Up/Reach-Down Driver

### Device Selection Table

Part Number	Package	Temp. Range
TC4404COA	8-Pin SOIC	0°C to +70°C
TC4404CPA	8-Pin PDIP	0°C to +70°C
TC4404EOA	8-Pin SOIC	-40°C to +85°C
TC4404EPA	8-Pin PDIP	-40°C to +85°C
TC4404MJA	8-Pin CERDIP	-55°C to +125°C
TC4405COA	8-Pin SOIC	0°C to +70°C
TC4405CPA	8-Pin PDIP	0°C to +70°C
TC4405EOA	8-Pin SOIC	-40°C to +85°C
TC4405EPA	8-Pin PDIP	-40°C to +85°C
TC4405MJA	8-Pin CERDIP	-55°C to +125°C

### General Description:

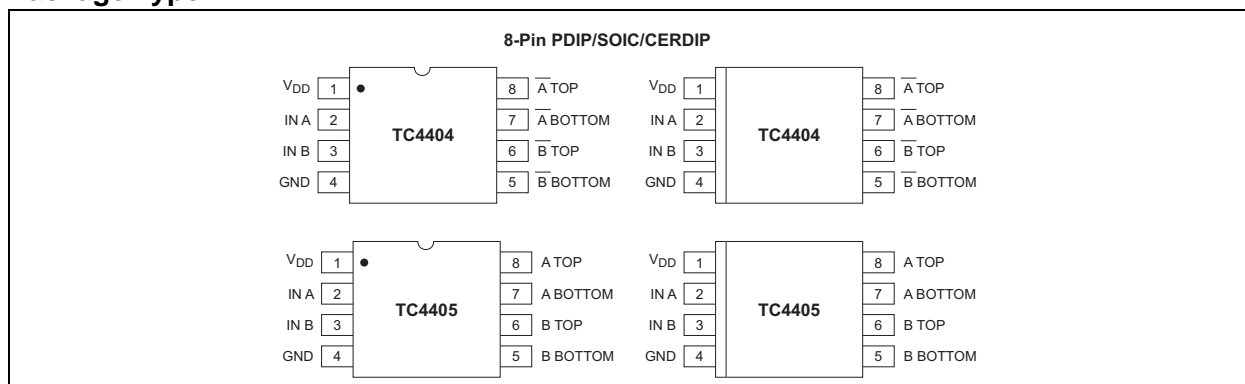
The TC4404/TC4405 are CMOS buffer-drivers constructed with complementary MOS outputs, where the drains of the totem-pole output have been left separated so that individual connections can be made to the pull-up and pull-down sections of the output. This allows the insertion of drain-current-limiting resistors in the pull-up and/or pull-down sections, allowing the user to define the rates of rise and fall for a capacitive load; or a reduced output swing, if driving a resistive load, or to limit base current, when driving a bipolar transistor. Minimum rise and fall times, with no resistors, will be less than 30 nsec for a 1000 pF load.

For driving MOSFETs in motor-control applications, where slow-ON/fast-OFF operation is desired, these devices are superior to the previously used technique of adding a diode-resistor combination between the driver output and the MOSFET, because they allow accurate control of turn-ON, while maintaining fast turn-OFF and maximum noise immunity for an OFF device.

When used to drive bipolar transistors, these drivers maintain the high speeds common to other Microchip drivers. They allow insertion of a base current-limiting resistor, while providing a separate half-output for fast turn-OFF. By proper positioning of the resistor, either npn or pnp transistors can be driven.

For driving many loads in low-power regimes, these drivers, because they eliminate shoot-through currents in the output stage, require significantly less power at higher frequencies, and can be helpful in meeting low-power budgets.

### Package Type

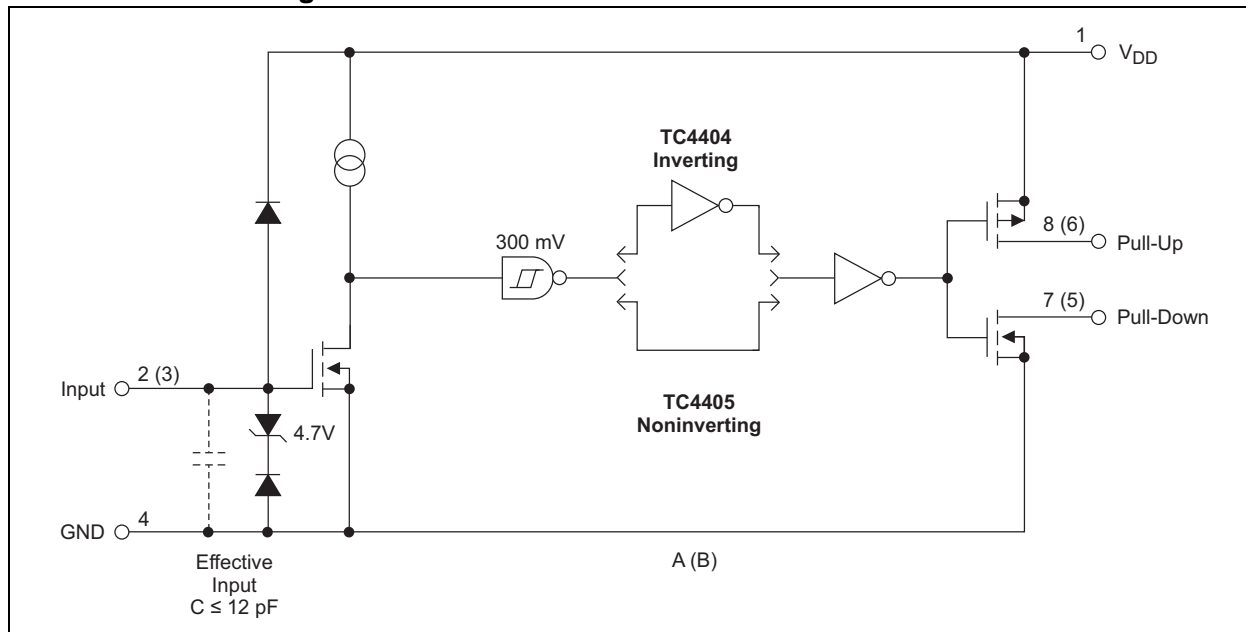


# TC4404/TC4405

Because neither drain in an output is dependent on the other, these devices can also be used as open-drain buffer/drivers where both drains are available in one device, thus minimizing chip count. Unused open drains should be returned to the supply rail that their device sources are connected to (pull-downs to ground, pull-ups to  $V_{DD}$ ), to prevent static damage. In addition, in situations where timing resistors or other means of limiting crossover currents are used, like drains may be paralleled for greater current carrying capacity.

These devices are built to operate in the most demanding electrical environments. They will not latch-up under any conditions within their power and voltage ratings; they are not subject to damage when up to 5V of noise spiking of either polarity occurs on their ground pin; and they can accept, without damage or logic upset, up to 1/2 amp of reverse current (of either polarity) being forced back into their outputs. All terminals are fully protected against up to 2 kV of electrostatic discharge.

## Functional Block Diagram



## 1.0 ELECTRICAL CHARACTERISTICS

### Absolute Maximum Ratings\*

Supply Voltage .....	+22V
Power Dissipation ( $T_A \leq 70^\circ\text{C}$ )	
PDIP .....	730 mW
CERDIP .....	800 mW
SOIC .....	470 mW
Package Thermal Resistance	
PDIP $R_{\theta J-A}$ .....	125°C/W
PDIP $R_{\theta J-C}$ .....	45°C/W
CERDIP $R_{\theta J-A}$ .....	150°C/W
CERDIP $R_{\theta J-C}$ .....	55°C/W
SOIC $R_{\theta J-A}$ .....	155°C/W
SOIC $R_{\theta J-C}$ .....	45°C/W
Operating Temperature Range	
C Version .....	0°C to +70°C
E Version .....	-40°C to +85°C
M Version .....	-55°C to +125°C
Storage Temperature Range .....	-65°C to +150°C

\*Stresses above those listed under "Absolute Maximum Ratings" may cause permanent damage to the device. These are stress ratings only and functional operation of the device at these or any other conditions above those indicated in the operation sections of the specifications is not implied. Exposure to Absolute Maximum Rating conditions for extended periods may affect device reliability.

## TC4404/TC4405 ELECTRICAL SPECIFICATIONS

Electrical Characteristics: $T_A = +25^\circ\text{C}$ , with $4.5\text{V} \leq V_{DD} \leq 18\text{V}$ , unless otherwise noted.						
Symbol	Parameter	Min	Typ	Max	Units	Test Conditions
<b>Input</b>						
$V_{IH}$	Logic 1, High Input Voltage	2.4	—	—	V	
$V_{IL}$	Logic 0, Low Input Voltage	—	—	0.8	V	
$I_{IN}$	Input Current	-1	—	1	$\mu\text{A}$	$0\text{V} \leq V_{IN} \leq V_{DD}$
<b>Output</b>						
$V_{OH}$	High Output Voltage	$V_{DD} - 0.025$	—	—	V	
$V_{OL}$	Low Output Voltage	—	—	0.025	V	
$R_O$	Output Resistance	—	7	10	$\Omega$	$I_{OUT} = 10\text{ mA}$ , $V_{DD} = 18\text{V}$ ; Any Drain
$I_{PK}$	Peak Output Current (Any Drain)	—	1.5	—	A	Duty cycle $\leq 2\%$ , $t \leq 300\ \mu\text{sec}$
$I_{DC}$	Continuous Output Current (Any Drain)	—	—	100	mA	
$I_R$	Latch-Up Protection (Any Drain) Withstand Reverse Current	—	>500	—	mA	Duty cycle $\leq 2\%$ , $t \leq 300\ \mu\text{sec}$
<b>Switching Time (Note 1)</b>						
$t_R$	Rise Time	—	25	30	nsec	Figure 3-1, $C_L = 1000\ \text{pF}$
$t_F$	Fall Time	—	25	30	nsec	Figure 3-1, $C_L = 1000\ \text{pF}$
$t_{D1}$	Delay Time	—	15	30	nsec	Figure 3-1, $C_L = 1000\ \text{pF}$
$t_{D2}$	Delay Time	—	32	50	nsec	Figure 3-1, $C_L = 1000\ \text{pF}$
<b>Power Supply</b>						
$I_S$	Power Supply Current	—	—	4.5	mA	$V_{IN} = 3\text{V}$ (Both Inputs)
		—	—	0.4		$V_{IN} = 0\text{V}$ (Both Inputs)

**Note 1:** Switching times ensured by design.

# TC4404/TC4405

## TC4404/TC4405 ELECTRICAL SPECIFICATIONS (CONTINUED)

**Electrical Characteristics:** Over operating temperature range with  $4.5V \leq V_{DD} \leq 18V$ , unless otherwise noted.

Symbol	Parameter	Min	Typ	Max	Units	Test Conditions
$V_{IH}$	Logic 1, High Input Voltage	2.4	—	—	V	
$V_{IL}$	Logic 0, Low Input Voltage	—	—	0.8	V	
$I_{IN}$	Input Current	-10	—	10	$\mu A$	$0V \leq V_{IN} \leq V_{DD}$
<b>Output</b>						
$V_{OH}$	High Output Voltage	$V_{DD} - 0.025$	—	—	V	
$V_{OL}$	Low Output Voltage	—	—	0.025	V	
$R_O$	Output Resistance	—	9	12	$\Omega$	$I_{OUT} = 10 \text{ mA}$ , $V_{DD} = 18V$ ; Any Drain
$I_{PK}$	Peak Output Current (Any Drain)	—	1.5	—	A	Duty cycle $\leq 2\%$ , $t \leq 300 \mu\text{sec}$
$I_{DC}$	Continuous Output Current (Any Drain)	—	—	100	mA	
$I_R$	Latch-Up Protection (Any Drain) Withstand Reverse Current	—	>500	—	mA	Duty cycle $\leq 2\%$ , $t \leq 300 \mu\text{sec}$
<b>Switching Time (Note 1)</b>						
$t_R$	Rise Time	—	—	40	nsec	Figure 3-1, $C_L = 1000 \text{ pF}$
$t_F$	Fall Time	—	—	40	nsec	Figure 3-1, $C_L = 1000 \text{ pF}$
$t_{D1}$	Delay Time	—	—	40	nsec	Figure 3-1, $C_L = 1000 \text{ pF}$
$t_{D2}$	Delay Time	—	—	60	nsec	Figure 3-1, $C_L = 1000 \text{ pF}$
<b>Power Supply</b>						
$I_S$	Power Supply Current	—	—	8	mA	$V_{IN} = 3V$ (Both Inputs)
		—	—	0.6		$V_{IN} = 0V$ (Both Inputs)

**Note 1:** Switching times ensured by design.

## 2.0 PIN DESCRIPTIONS

The descriptions of the pins are listed in Table 2-1.

**TABLE 2-1: PIN FUNCTION TABLE**

Pin No. (8-Pin PDIP, SOIC, CERDIP)	Symbol	Description
1	V <sub>DD</sub>	Supply input, 4.5V to 18V.
2	IN A	Control input A, TTL/CMOS compatible input.
3	IN B	Control input A, TTL/CMOS compatible input.
4	GND	Ground.
5	B BOTTOM	Output B, pull-down.
6	B TOP	Output B, pull-up.
7	A BOTTOM	Output A, pull-down.
8	A TOP	Output A, pull-up.

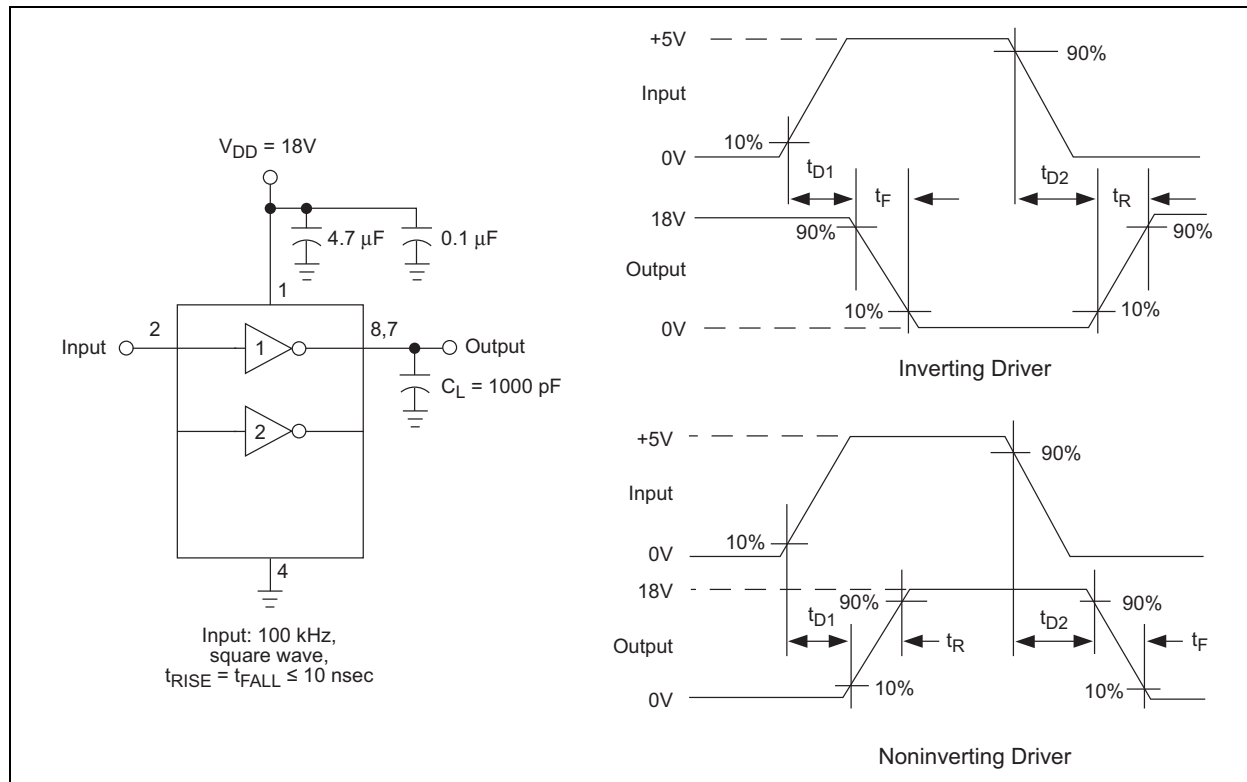
# TC4404/TC4405

## 3.0 APPLICATIONS INFORMATION

### 3.1 Circuit Layout Guidelines

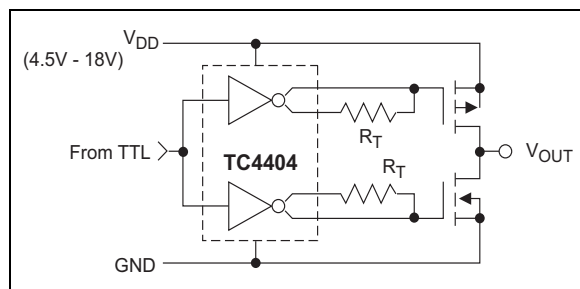
Avoid long power supply and ground traces (added inductance causes unwanted voltage transients). Use power and ground planes wherever possible.

In addition, it is advisable that low ESR bypass capacitors (4.7  $\mu$ F or 10  $\mu$ F tantalum) be placed as close to the driver as possible. The driver should be physically located as close to the device it is driving as possible to minimize the length of the output trace.

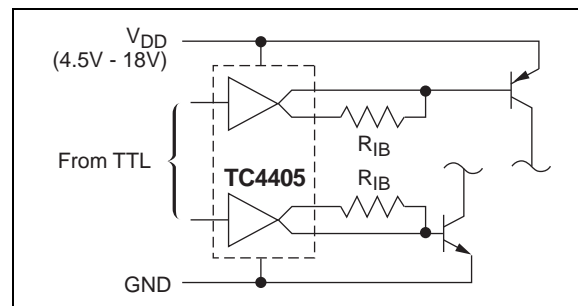


**FIGURE 3-1:** Switching Time Test Circuit

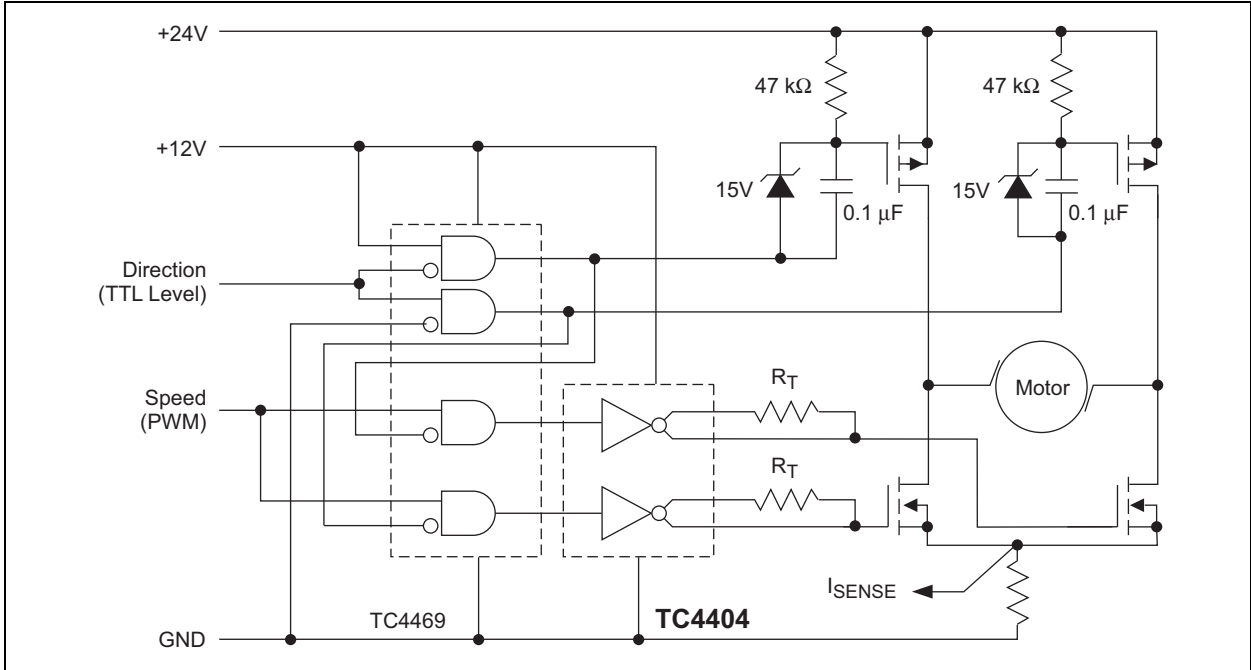
### 3.2 Typical Applications



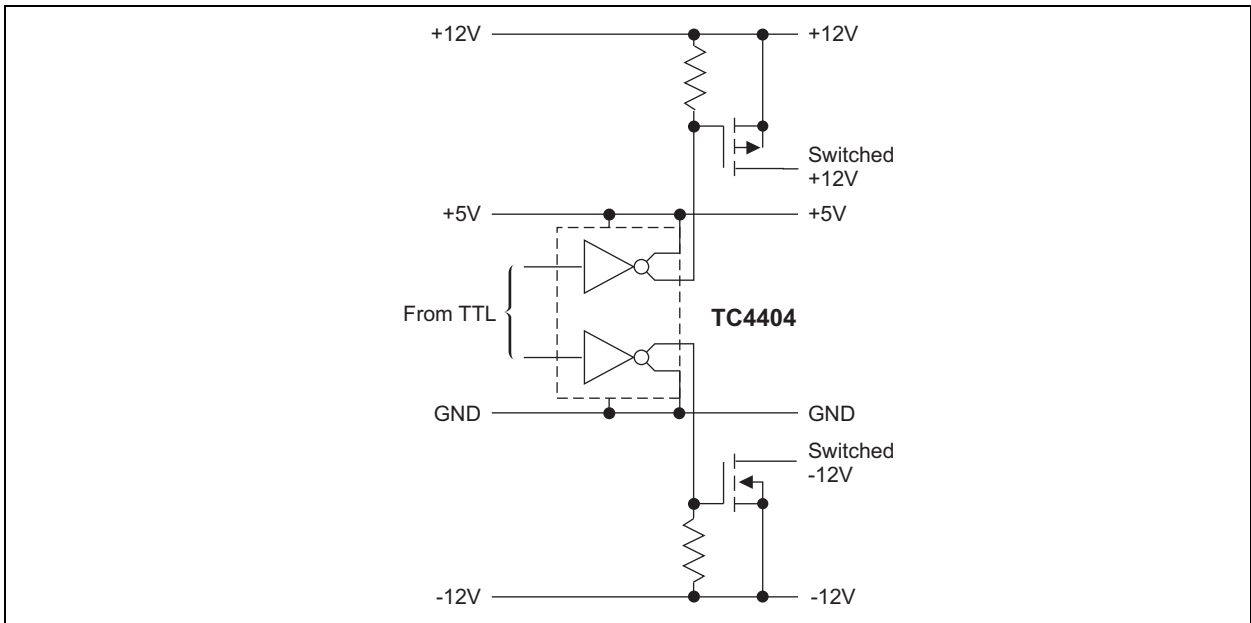
**FIGURE 3-2:** Zero Crossover Current Totem-Pole Switch



**FIGURE 3-3:** Driving Bipolar Transistors



**FIGURE 3-4:** Servo Motor Control

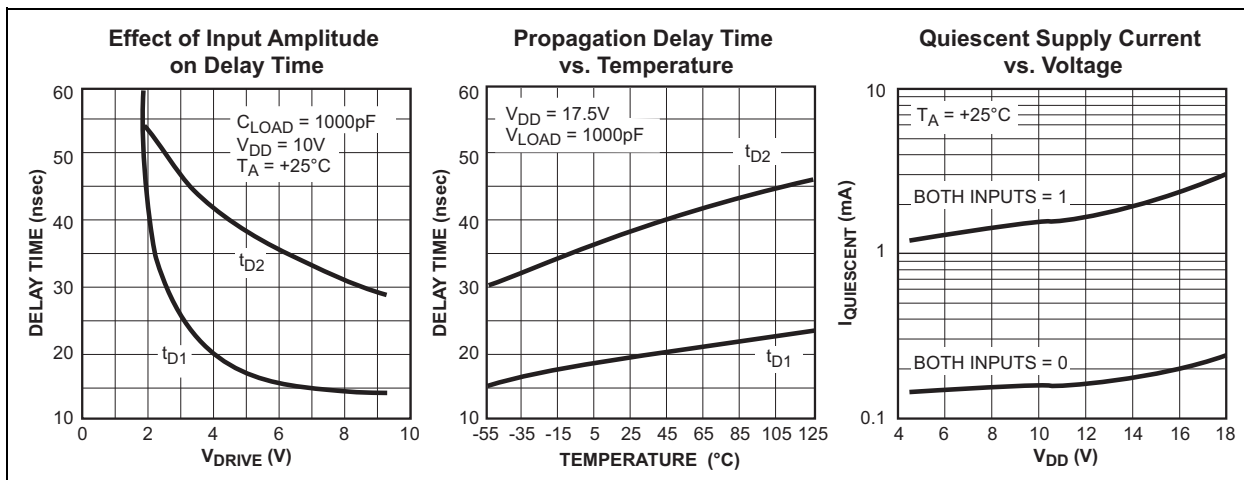
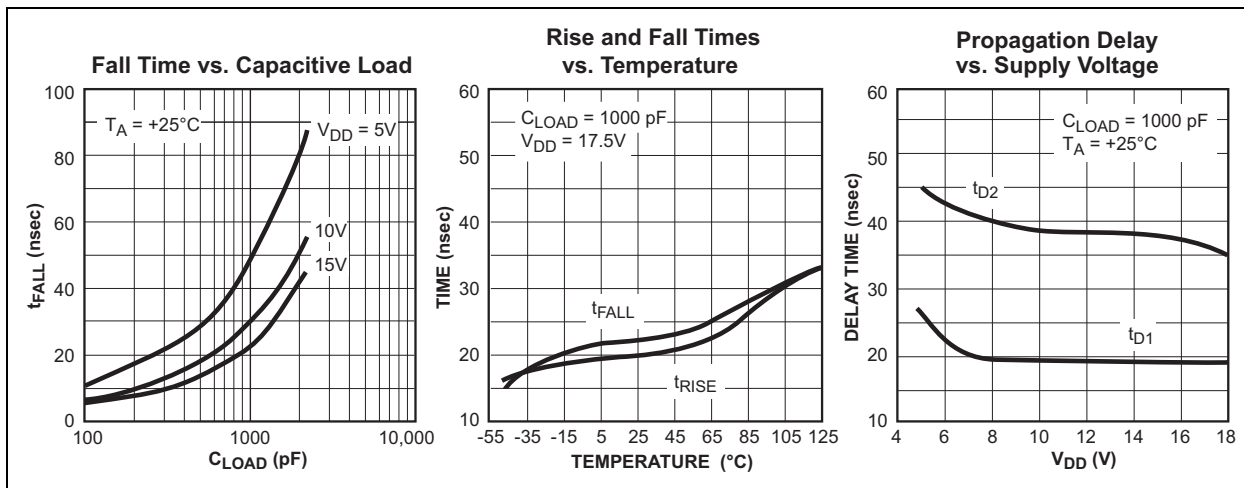
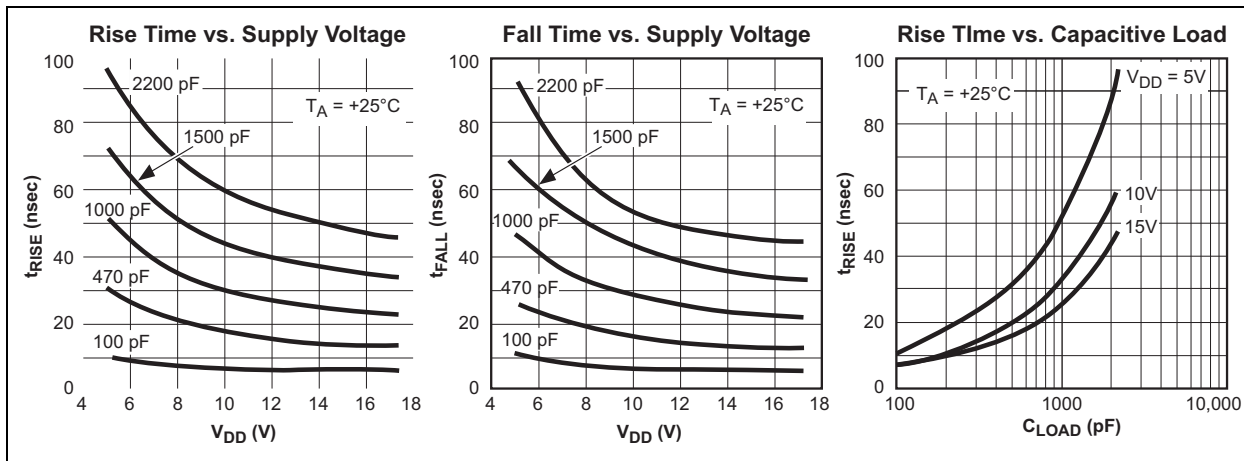


**FIGURE 3-5:** Reach-Up and Reach-Down Driving

# TC4404/TC4405

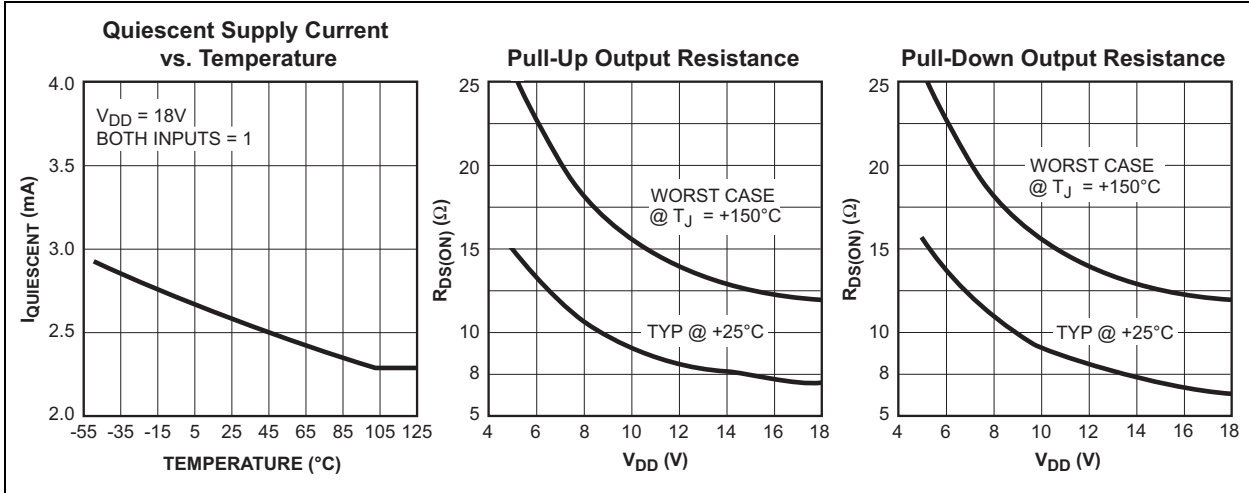
## 4.0 TYPICAL CHARACTERISTICS

**Note:** The graphs and tables provided following this note are a statistical summary based on a limited number of samples and are provided for informational purposes only. The performance characteristics listed herein are not tested or guaranteed. In some graphs or tables, the data presented may be outside the specified operating range (e.g., outside specified power supply range) and therefore outside the warranted range.





## TYPICAL CHARACTERISTICS (CONTINUED)



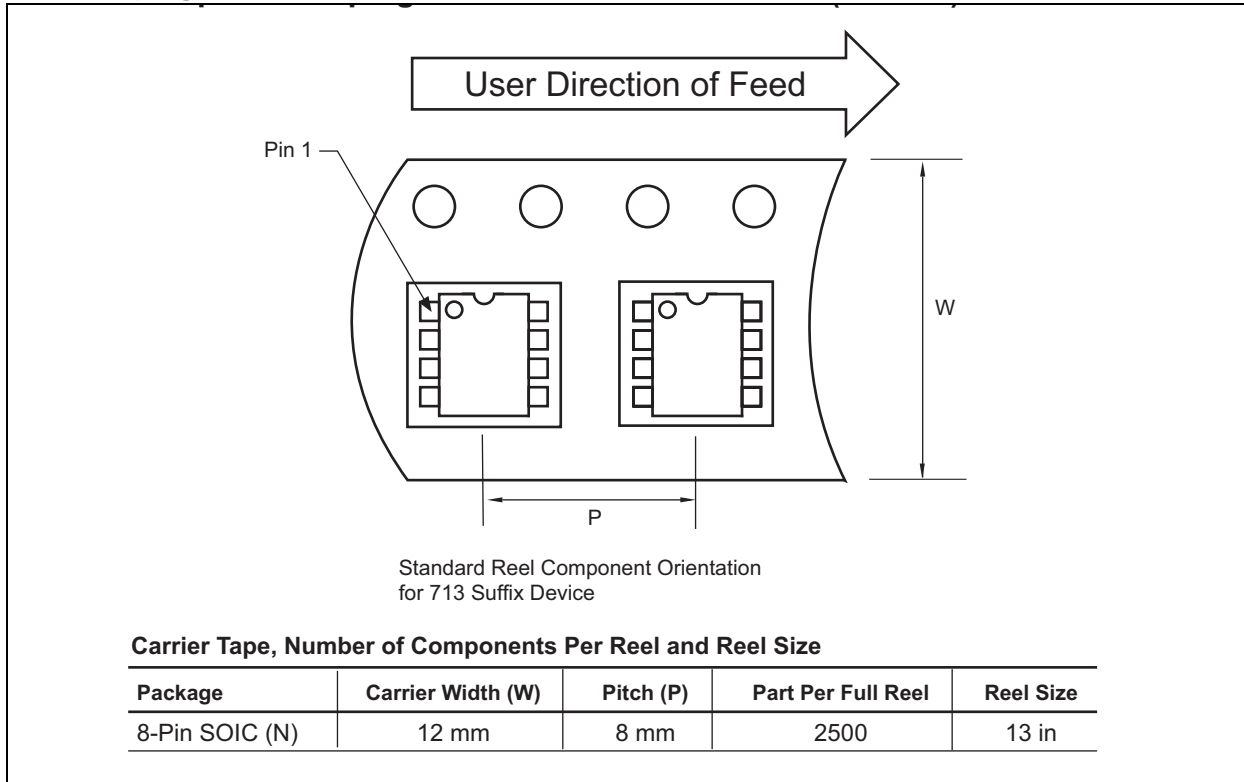
# TC4404/TC4405

## 5.0 PACKAGING INFORMATION

### 5.1 Package Marking Information

Package marking data not available at this time.

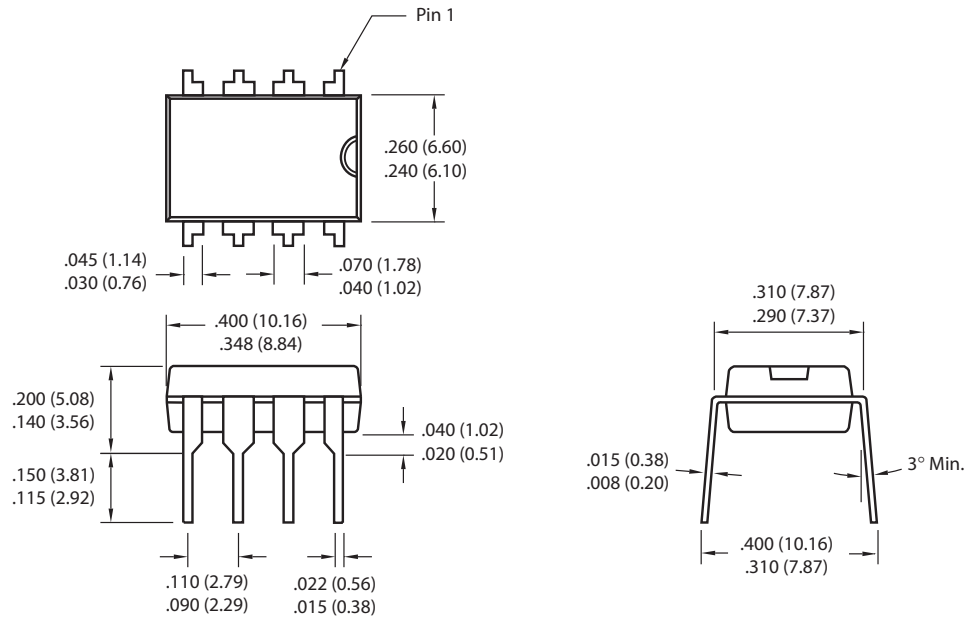
### 5.2 Taping Form



## 5.3 Package Dimensions

**Note:** For the most current package drawings, please see the Microchip Packaging Specification located at <http://www.microchip.com/packaging>

### 8-Pin Plastic DIP



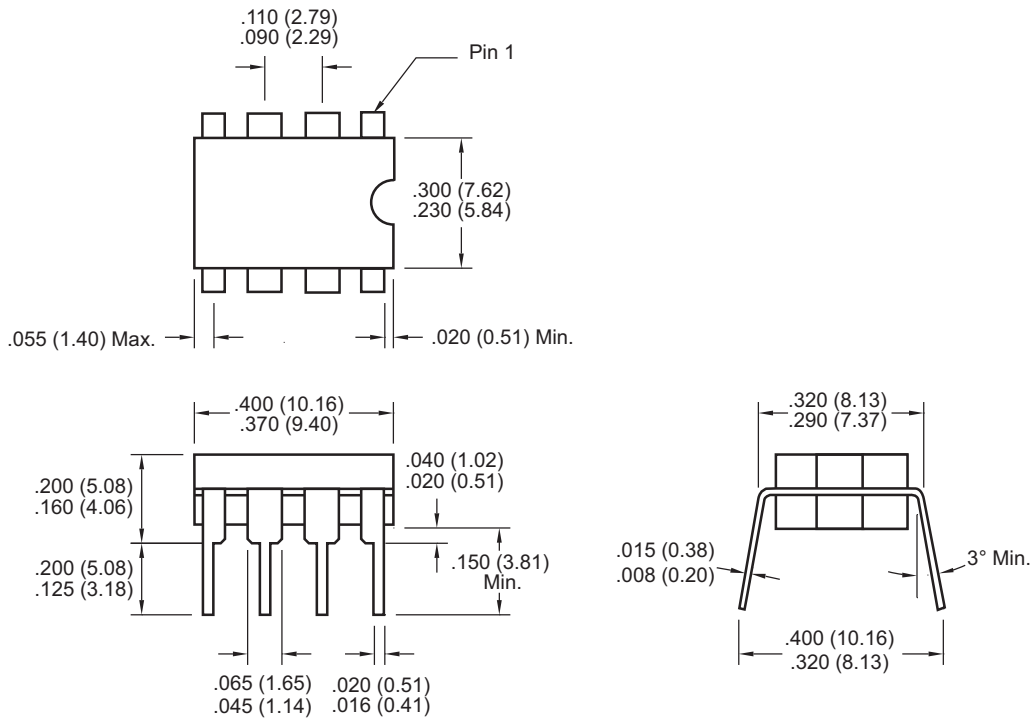
Dimensions: inches (mm)

# TC4404/TC4405

## Package Dimensions (Continued)

**Note:** For the most current package drawings, please see the Microchip Packaging Specification located at <http://www.microchip.com/packaging>

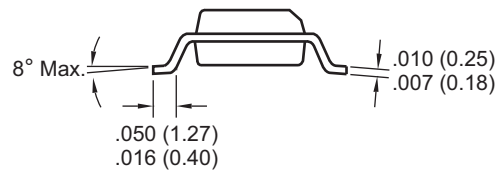
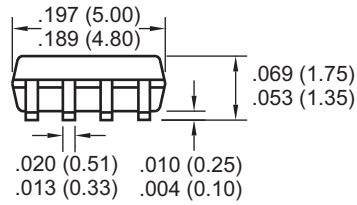
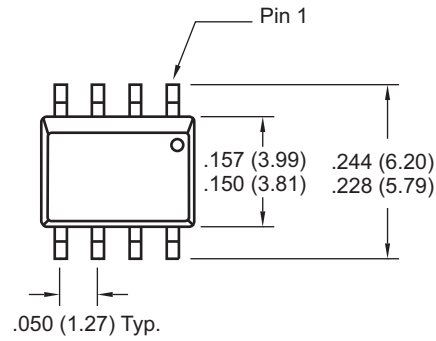
### 8-Pin Cerdip (Narrow)



Dimensions: inches (mm)

**Note:** For the most current package drawings, please see the Microchip Packaging Specification located at <http://www.microchip.com/packaging>

## 8-Pin SOIC



Dimensions: inches (mm)

# TC4404/TC4405

---

## 6.0 REVISION HISTORY

### Revision D (December 2012)

Added a note to each package outline drawing.

## THE MICROCHIP WEB SITE

Microchip provides online support via our WWW site at [www.microchip.com](http://www.microchip.com). This web site is used as a means to make files and information easily available to customers. Accessible by using your favorite Internet browser, the web site contains the following information:

- **Product Support** – Data sheets and errata, application notes and sample programs, design resources, user's guides and hardware support documents, latest software releases and archived software
- **General Technical Support** – Frequently Asked Questions (FAQ), technical support requests, online discussion groups, Microchip consultant program member listing
- **Business of Microchip** – Product selector and ordering guides, latest Microchip press releases, listing of seminars and events, listings of Microchip sales offices, distributors and factory representatives

## CUSTOMER CHANGE NOTIFICATION SERVICE

Microchip's customer notification service helps keep customers current on Microchip products. Subscribers will receive e-mail notification whenever there are changes, updates, revisions or errata related to a specified product family or development tool of interest.

To register, access the Microchip web site at [www.microchip.com](http://www.microchip.com). Under "Support", click on "Customer Change Notification" and follow the registration instructions.

## CUSTOMER SUPPORT

Users of Microchip products can receive assistance through several channels:

- Distributor or Representative
- Local Sales Office
- Field Application Engineer (FAE)
- Technical Support

Customers should contact their distributor, representative or field application engineer (FAE) for support. Local sales offices are also available to help customers. A listing of sales offices and locations is included in the back of this document.

**Technical support is available through the web site at: <http://microchip.com/support>**

# TC4404/TC4405

---

---

## READER RESPONSE

It is our intention to provide you with the best documentation possible to ensure successful use of your Microchip product. If you wish to provide your comments on organization, clarity, subject matter, and ways in which our documentation can better serve you, please FAX your comments to the Technical Publications Manager at (480) 792-4150.

Please list the following information, and use this outline to provide us with your comments about this document.

TO: Technical Publications Manager Total Pages Sent \_\_\_\_\_

RE: Reader Response

From: Name \_\_\_\_\_

Company \_\_\_\_\_

Address \_\_\_\_\_

City / State / ZIP / Country \_\_\_\_\_

Telephone: (\_\_\_\_\_) \_\_\_\_\_ - \_\_\_\_\_ FAX: (\_\_\_\_\_) \_\_\_\_\_ - \_\_\_\_\_

Application (optional):

Would you like a reply?  Y  N

Device: TC4404/TC4405

Literature Number: DS21418D

Questions:

1. What are the best features of this document?

\_\_\_\_\_  
\_\_\_\_\_

2. How does this document meet your hardware and software development needs?

\_\_\_\_\_  
\_\_\_\_\_

3. Do you find the organization of this document easy to follow? If not, why?

\_\_\_\_\_  
\_\_\_\_\_

4. What additions to the document do you think would enhance the structure and subject?

\_\_\_\_\_  
\_\_\_\_\_

5. What deletions from the document could be made without affecting the overall usefulness?

\_\_\_\_\_  
\_\_\_\_\_

6. Is there any incorrect or misleading information (what and where)?

\_\_\_\_\_  
\_\_\_\_\_

7. How would you improve this document?

\_\_\_\_\_  
\_\_\_\_\_



---

**Note the following details of the code protection feature on Microchip devices:**

- Microchip products meet the specification contained in their particular Microchip Data Sheet.
- Microchip believes that its family of products is one of the most secure families of its kind on the market today, when used in the intended manner and under normal conditions.
- There are dishonest and possibly illegal methods used to breach the code protection feature. All of these methods, to our knowledge, require using the Microchip products in a manner outside the operating specifications contained in Microchip's Data Sheets. Most likely, the person doing so is engaged in theft of intellectual property.
- Microchip is willing to work with the customer who is concerned about the integrity of their code.
- Neither Microchip nor any other semiconductor manufacturer can guarantee the security of their code. Code protection does not mean that we are guaranteeing the product as “unbreakable.”

Code protection is constantly evolving. We at Microchip are committed to continuously improving the code protection features of our products. Attempts to break Microchip's code protection feature may be a violation of the Digital Millennium Copyright Act. If such acts allow unauthorized access to your software or other copyrighted work, you may have a right to sue for relief under that Act.

---

Information contained in this publication regarding device applications and the like is provided only for your convenience and may be superseded by updates. It is your responsibility to ensure that your application meets with your specifications. MICROCHIP MAKES NO REPRESENTATIONS OR WARRANTIES OF ANY KIND WHETHER EXPRESS OR IMPLIED, WRITTEN OR ORAL, STATUTORY OR OTHERWISE, RELATED TO THE INFORMATION, INCLUDING BUT NOT LIMITED TO ITS CONDITION, QUALITY, PERFORMANCE, MERCHANTABILITY OR FITNESS FOR PURPOSE. Microchip disclaims all liability arising from this information and its use. Use of Microchip devices in life support and/or safety applications is entirely at the buyer's risk, and the buyer agrees to defend, indemnify and hold harmless Microchip from any and all damages, claims, suits, or expenses resulting from such use. No licenses are conveyed, implicitly or otherwise, under any Microchip intellectual property rights.

#### **Trademarks**

The Microchip name and logo, the Microchip logo, dsPIC, FlashFlex, KEELOQ, KEELOQ logo, MPLAB, PIC, PICmicro, PICSTART, PIC<sup>32</sup> logo, rPIC, SST, SST Logo, SuperFlash and UNI/O are registered trademarks of Microchip Technology Incorporated in the U.S.A. and other countries.

FilterLab, Hampshire, HI-TECH C, Linear Active Thermistor, MTP, SEEVAL and The Embedded Control Solutions Company are registered trademarks of Microchip Technology Incorporated in the U.S.A.

Silicon Storage Technology is a registered trademark of Microchip Technology Inc. in other countries.

Analog-for-the-Digital Age, Application Maestro, BodyCom, chipKIT, chipKIT logo, CodeGuard, dsPICDEM, dsPICDEM.net, dsPICworks, dsSPEAK, ECAN, ECONOMONITOR, FanSense, HI-TIDE, In-Circuit Serial Programming, ICSP, Mindi, MiWi, MPASM, MPF, MPLAB Certified logo, MPLIB, MPLINK, mTouch, Omniclient Code Generation, PICC, PICC-18, PICDEM, PICDEM.net, PICkit, PICtail, REAL ICE, rLAB, Select Mode, SQI, Serial Quad I/O, Total Endurance, TSHARC, UniWinDriver, WiperLock, ZENA and Z-Scale are trademarks of Microchip Technology Incorporated in the U.S.A. and other countries.

SQTP is a service mark of Microchip Technology Incorporated in the U.S.A.

GestIC and ULPP are registered trademarks of Microchip Technology Germany II GmbH & Co. & KG, a subsidiary of Microchip Technology Inc., in other countries.

All other trademarks mentioned herein are property of their respective companies.

© 2002-2012, Microchip Technology Incorporated, Printed in the U.S.A., All Rights Reserved.

 Printed on recycled paper.

ISBN: 9781620767931

*Microchip received ISO/TS-16949:2009 certification for its worldwide headquarters, design and wafer fabrication facilities in Chandler and Tempe, Arizona; Gresham, Oregon and design centers in California and India. The Company's quality system processes and procedures are for its PIC<sup>®</sup> MCUs and dsPIC<sup>®</sup> DSCs, KEELOQ<sup>®</sup> code hopping devices, Serial EEPROMs, microperipherals, nonvolatile memory and analog products. In addition, Microchip's quality system for the design and manufacture of development systems is ISO 9001:2000 certified.*

---

**QUALITY MANAGEMENT SYSTEM**  
**CERTIFIED BY DNV**  
**== ISO/TS 16949 ==**



# MICROCHIP

## Worldwide Sales and Service

### AMERICAS

**Corporate Office**  
2355 West Chandler Blvd.  
Chandler, AZ 85224-6199  
Tel: 480-792-7200  
Fax: 480-792-7277  
Technical Support:  
<http://www.microchip.com/support>  
Web Address:  
[www.microchip.com](http://www.microchip.com)

**Atlanta**  
Duluth, GA  
Tel: 678-957-9614  
Fax: 678-957-1455

**Boston**  
Westborough, MA  
Tel: 774-760-0087  
Fax: 774-760-0088

**Chicago**  
Itasca, IL  
Tel: 630-285-0071  
Fax: 630-285-0075

**Cleveland**  
Independence, OH  
Tel: 216-447-0464  
Fax: 216-447-0643

**Dallas**  
Addison, TX  
Tel: 972-818-7423  
Fax: 972-818-2924

**Detroit**  
Farmington Hills, MI  
Tel: 248-538-2250  
Fax: 248-538-2260

**Indianapolis**  
Noblesville, IN  
Tel: 317-773-8323  
Fax: 317-773-5453

**Los Angeles**  
Mission Viejo, CA  
Tel: 949-462-9523  
Fax: 949-462-9608

**Santa Clara**  
Santa Clara, CA  
Tel: 408-961-6444  
Fax: 408-961-6445

**Toronto**  
Mississauga, Ontario,  
Canada  
Tel: 905-673-0699  
Fax: 905-673-6509

### ASIA/PACIFIC

**Asia Pacific Office**  
Suites 3707-14, 37th Floor  
Tower 6, The Gateway  
Harbour City, Kowloon  
Hong Kong  
Tel: 852-2401-1200  
Fax: 852-2401-3431

**Australia - Sydney**  
Tel: 61-2-9868-6733  
Fax: 61-2-9868-6755

**China - Beijing**  
Tel: 86-10-8569-7000  
Fax: 86-10-8528-2104

**China - Chengdu**  
Tel: 86-28-8665-5511  
Fax: 86-28-8665-7889

**China - Chongqing**  
Tel: 86-23-8980-9588  
Fax: 86-23-8980-9500

**China - Hangzhou**  
Tel: 86-571-2819-3187  
Fax: 86-571-2819-3189

**China - Hong Kong SAR**  
Tel: 852-2943-5100  
Fax: 852-2401-3431

**China - Nanjing**  
Tel: 86-25-8473-2460  
Fax: 86-25-8473-2470

**China - Qingdao**  
Tel: 86-532-8502-7355  
Fax: 86-532-8502-7205

**China - Shanghai**  
Tel: 86-21-5407-5533  
Fax: 86-21-5407-5066

**China - Shenyang**  
Tel: 86-24-2334-2829  
Fax: 86-24-2334-2393

**China - Shenzhen**  
Tel: 86-755-8864-2200  
Fax: 86-755-8203-1760

**China - Wuhan**  
Tel: 86-27-5980-5300  
Fax: 86-27-5980-5118

**China - Xian**  
Tel: 86-29-8833-7252  
Fax: 86-29-8833-7256

**China - Xiamen**  
Tel: 86-592-2388138  
Fax: 86-592-2388130

**China - Zhuhai**  
Tel: 86-756-3210040  
Fax: 86-756-3210049

### ASIA/PACIFIC

**India - Bangalore**  
Tel: 91-80-3090-4444  
Fax: 91-80-3090-4123

**India - New Delhi**  
Tel: 91-11-4160-8631  
Fax: 91-11-4160-8632

**India - Pune**  
Tel: 91-20-2566-1512  
Fax: 91-20-2566-1513

**Japan - Osaka**  
Tel: 81-66-152-7160  
Fax: 81-66-152-9310

**Japan - Yokohama**  
Tel: 81-45-471-6166  
Fax: 81-45-471-6122

**Korea - Daegu**  
Tel: 82-53-744-4301  
Fax: 82-53-744-4302

**Korea - Seoul**  
Tel: 82-2-554-7200  
Fax: 82-2-558-5932 or  
82-2-558-5934

**Malaysia - Kuala Lumpur**  
Tel: 60-3-6201-9857  
Fax: 60-3-6201-9859

**Malaysia - Penang**  
Tel: 60-4-227-8870  
Fax: 60-4-227-4068

**Philippines - Manila**  
Tel: 63-2-634-9065  
Fax: 63-2-634-9069

**Singapore**  
Tel: 65-6334-8870  
Fax: 65-6334-8850

**Taiwan - Hsin Chu**  
Tel: 886-3-5778-366  
Fax: 886-3-5770-955

**Taiwan - Kaohsiung**  
Tel: 886-7-213-7828  
Fax: 886-7-330-9305

**Taiwan - Taipei**  
Tel: 886-2-2508-8600  
Fax: 886-2-2508-0102

**Thailand - Bangkok**  
Tel: 66-2-694-1351  
Fax: 66-2-694-1350

### EUROPE

**Austria - Wels**  
Tel: 43-7242-2244-39  
Fax: 43-7242-2244-393

**Denmark - Copenhagen**  
Tel: 45-4450-2828  
Fax: 45-4485-2829

**France - Paris**  
Tel: 33-1-69-53-63-20  
Fax: 33-1-69-30-90-79

**Germany - Munich**  
Tel: 49-89-627-144-0  
Fax: 49-89-627-144-44

**Italy - Milan**  
Tel: 39-0331-742611  
Fax: 39-0331-466781

**Netherlands - Drunen**  
Tel: 31-416-690399  
Fax: 31-416-690340

**Spain - Madrid**  
Tel: 34-91-708-08-90  
Fax: 34-91-708-08-91

**UK - Wokingham**  
Tel: 44-118-921-5869  
Fax: 44-118-921-5820

11/27/12

Компания «Океан Электроники» предлагает заключение долгосрочных отношений при поставках импортных электронных компонентов на взаимовыгодных условиях!

Наши преимущества:

- Поставка оригинальных импортных электронных компонентов напрямую с производств Америки, Европы и Азии, а так же с крупнейших складов мира;
- Широкая линейка поставок активных и пассивных импортных электронных компонентов (более 30 млн. наименований);
- Поставка сложных, дефицитных, либо снятых с производства позиций;
- Оперативные сроки поставки под заказ (от 5 рабочих дней);
- Экспресс доставка в любую точку России;
- Помощь Конструкторского Отдела и консультации квалифицированных инженеров;
- Техническая поддержка проекта, помощь в подборе аналогов, поставка прототипов;
- Поставка электронных компонентов под контролем ВП;
- Система менеджмента качества сертифицирована по Международному стандарту ISO 9001;
- При необходимости вся продукция военного и аэрокосмического назначения проходит испытания и сертификацию в лаборатории (по согласованию с заказчиком);
- Поставка специализированных компонентов военного и аэрокосмического уровня качества (Xilinx, Altera, Analog Devices, Intersil, Interpoint, Microsemi, Actel, Aeroflex, Peregrine, VPT, Syfer, Eurofarad, Texas Instruments, MS Kennedy, Miteq, Cobham, E2V, MA-COM, Hittite, Mini-Circuits, General Dynamics и др.);

Компания «Океан Электроники» является официальным дистрибьютором и эксклюзивным представителем в России одного из крупнейших производителей разъемов военного и аэрокосмического назначения «JONHON», а так же официальным дистрибьютором и эксклюзивным представителем в России производителя высокотехнологичных и надежных решений для передачи СВЧ сигналов «FORSTAR».



## JONHON

«JONHON» (основан в 1970 г.)

Разъемы специального, военного и аэрокосмического назначения:

(Применяются в военной, авиационной, аэрокосмической, морской, железнодорожной, горно- и нефтедобывающей отраслях промышленности)

«FORSTAR» (основан в 1998 г.)

ВЧ соединители, коаксиальные кабели, кабельные сборки и микроволновые компоненты:

(Применяются в телекоммуникациях гражданского и специального назначения, в средствах связи, РЛС, а так же военной, авиационной и аэрокосмической отраслях промышленности).



Телефон: 8 (812) 309-75-97 (многоканальный)

Факс: 8 (812) 320-03-32

Электронная почта: [ocean@oceanchips.ru](mailto:ocean@oceanchips.ru)

Web: <http://oceanchips.ru/>

Адрес: 198099, г. Санкт-Петербург, ул. Калинина, д. 2, корп. 4, лит. А