

NCV885300

Automotive Grade Non-Synchronous Buck Controller

The NCV885300 is an adjustable-output non-synchronous buck controller which drives an external P-channel MOSFET. The device uses peak current mode control with internal slope compensation. The IC incorporates an internal regulator that supplies charge to the gate driver.

Protection features include internal soft-start, undervoltage lockout, cycle-by-cycle current limit, hiccup-mode overcurrent protection, hiccup-mode short-circuit protection.

Additional features include: power good signal, low quiescent current sleep mode and externally synchronizable switching frequency.

Features

- Ultra Low Iq Sleep Mode
- Adjustable Output with 800 mV $\pm 2.0\%$ Reference Voltage
- Wide Input of 3.1 to 44 V with Undervoltage Lockout (UVLO)
- Power Good (PG)
- Internal Soft-Start (SS)
- Fixed-Frequency Peak Current Mode Control
- Internal Slope Compensating Artificial Ramp
- Internal High-Side PMOS Gate Driver
- Regulated Gate Driver Current Source
- External Frequency Synchronization (SYNC)
- Programmable Cycle-by-Cycle Current Limit (CL)
- Hiccup Overcurrent Protection (OCP)
- Output Short Circuit Hiccup Protection (SCP)
- Space-Saving 8-PIN SOIC Package
- NCV Prefix for Automotive and Other Applications Requiring Unique Site and Control Change Requirements; AEC-Q100 Qualified and PPAP Capable
- These Devices are Pb-Free and are RoHS Compliant



ON Semiconductor®

<http://onsemi.com>

MARKING DIAGRAM



V885300 = Specific Device Code
A = Assembly Location
L = Wafer Lot
Y = Year
W = Work Week
▪ = Pb-Free Package

PINOUT DIAGRAM

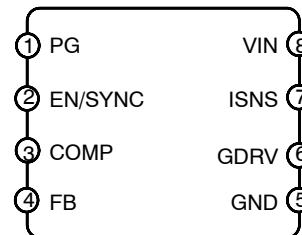

ORDERING INFORMATION

Device	Package	Shipping†
NCV885300D1R2G	SOIC-8 (Pb-Free)	2500/Tape & Reel

† For information on tape and reel specifications, including part orientation and tape sizes, please refer to our Tape and Reel Packaging Specification Brochure, BRD8011/D.

NCV885300

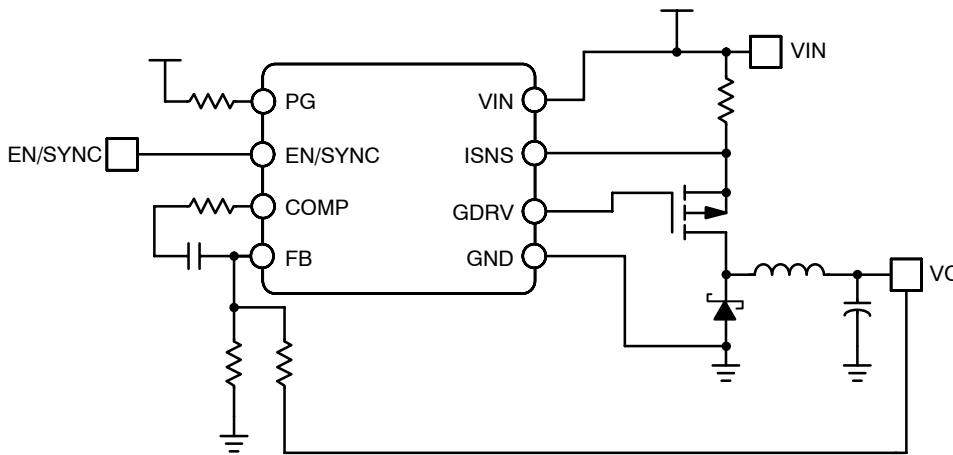

Figure 1. NCV885300 Application Diagram

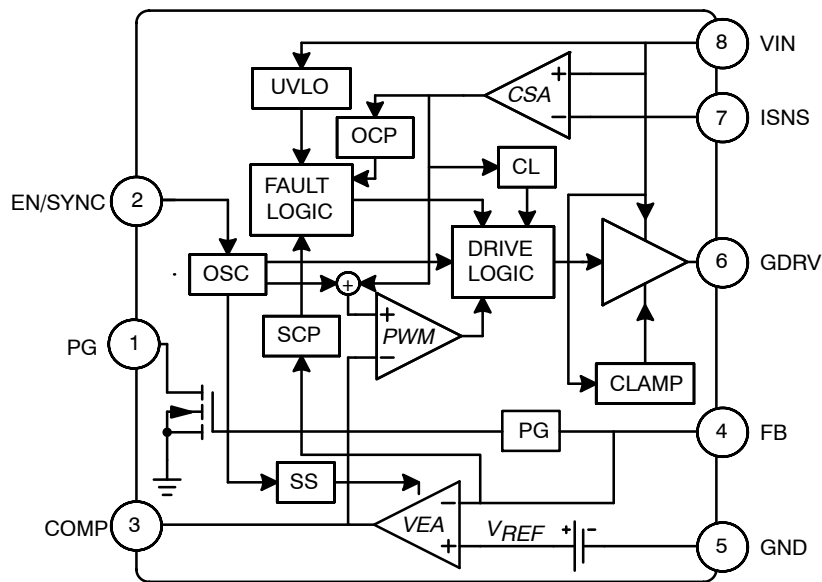

Figure 2. NCV885300 Simple Block Diagram

PIN DESCRIPTIONS

No	Pin Symbol	Function
1	PG	Power good output. Use a pull-up resistor to 5.0 V. PG is pulled low when power is not good.
2	EN/SYNC	Enable and synchronization input. The falling edge synchronizes the internal oscillator. The part is disabled into sleep mode when this pin is brought low for longer than the enable time-out period.
3	COMP	Output of the voltage error amplifier. An external compensator network from COMP to GND is used to stabilize the converter and tailor transient performance.
4	FB	Output voltage feedback. A resistor from the output voltage to FB with another resistor from FB to GND creates a voltage divider for regulation and programming of the output voltage.
5	GND	Ground reference.
6	GDRV	Gate driver output. Connect to gate of the external P-channel MOSFET. A series resistance can be added from GDRV to the gate to tailor EMC performance.
7	ISNS	Current sense input. Connect this pin to the source of the external P-channel MOSFET, through a current-sense resistor to VIN to sense the switching current for regulation and current limiting.
8	VIN	Main power input for the IC.

NCV885300

MAXIMUM RATINGS (Voltages are with respect to GND unless otherwise indicated.)

Rating	Value	Unit
DC Voltage (VIN, ISNS, GDRV)	-0.3 to 44	V
Peak Transient Voltage (Load Dump on VIN)	44	V
DC Voltage (EN/SYNC, PG)	-0.3 to 6.0	V
DC Voltage (COMP, FB)	-0.3 to 3.6	V
DC Voltage Stress (VIN - GDRV)	-0.7 to 12	V
Operating Junction Temperature Range	-40 to 150	°C
Storage Temperature Range	-65 to 150	°C
Peak Reflow Soldering Temperature: Pb-Free 60 to 150 seconds at 217°C	265	°C

Stresses exceeding Maximum Ratings may damage the device. Maximum Ratings are stress ratings only. Functional operation above the Recommended Operating Conditions is not implied. Extended exposure to stresses above the Recommended Operating Conditions may affect device reliability.

PACKAGE ATTRIBUTES

Characteristic	Value
ESD Capability Human Body Model Machine Model Charge Device Model	2.0 kV 200 V >1.0 kV
Moisture Sensitivity Level	MSL 1 260°C
Package Thermal Resistance Junction-to-Ambient, $R_{\theta JA}$	100°C/W

NCV885300

ELECTRICAL CHARACTERISTICS

($-40^{\circ}\text{C} < T_J < 150^{\circ}\text{C}$, $3.4\text{ V} < V_{IN} < 36\text{ V}$, $EN = 5\text{ V}$, no sync, unless otherwise specified)

Characteristic	Symbol	Conditions	Min	Typ	Max	Unit
----------------	--------	------------	-----	-----	-----	------

GENERAL

Quiescent Current	$I_{q,sleep}$	$V_{IN} = 13.2\text{ V}$, $EN = 0\text{ V}$, Sleep Mode		2.5	6.0	μA
	$I_{q,off}$	$V_{IN} = 13.2\text{ V}$, $EN = 5\text{ V}$ or toggled, $V_{FB} = 1\text{ V}$, No Switching		2.0	3.0	mA
	$I_{q,on}$	$V_{IN} = 13.2\text{ V}$, $EN = 5\text{ V}$ or toggled, $V_{FB} = 0\text{ V}$, Switching		3.0	5.0	mA
Undervoltage Lockout	V_{uvlo}	V_{IN} decreasing	2.9	3.1	3.3	V
Undervoltage Lockout Hysteresis	$V_{uvlo,hys}$		50	150	300	mV
Overvoltage Lockout	V_{ovlo}		36.9	38	39.3	V

OSCILLATOR

Switching Frequency	F_{SW}		306	340	374	kHz
Slope Compensation	m_a			51		$\text{mV}/\mu\text{s}$
Minimum On Time	t_{onmin}		90	110	140	ns
Minimum Off Time	t_{offmin}			93		$\%$
Max Duty Cycle	D_{max}			100		$\%$
Soft-Start Time	t_{ss}		1.0	1.5	2.0	ms
Soft-Start Delay	$t_{ss,dly}$		200	300	400	μs

EN/SYNC

Low Threshold	$V_{s,il}$				0.8	V
High Threshold	$V_{s,ih}$		2.0			V
Input Current	I_{sync}			5.0	10	μA
SYNC Frequency Range	f_{sync}	Relative to Nominal Switching Frequency	80		300	$\%$
SYNC Delay	$t_{s,dly}$	From SYNC falling edge to GDRV falling edge		50	100	ns
SYNC Duty Cycle	D_{sync}		25		75	$\%$
Disable Delay Time	t_{en}	$\%$ of F_{SW}		300		$\%$

POWER GOOD

Rising Threshold	PG_{rise}	$\%$ of V_{ref}	87	90	93	$\%$
Falling Threshold	PG_{fall}	$\%$ of V_{ref}	90	93	96	$\%$
Power Good Pulldown	V_{pg}				0.40	V

VOLTAGE ERROR AMP

DC Gain	A_v		55	80	91	dB
Gain-Bandwidth Product	G_{BW}		1.7	2.4	3.1	MHz
FB Bias Current	$I_{vfb,bias}$			0.1	1.0	μA
Charge Currents	$I_{src,vea}$	Source, $V_{FB} = 0.9\text{ V}$, $V_{COMP} = 1.2\text{ V}$	1.2	1.8	2.5	mA
	$I_{snk,vea}$	Sink, $V_{FB} = 0.7\text{ V}$, $V_{COMP} = 1.2\text{ V}$	0.5	0.8	1.0	
Reference Voltage	V_{ref}		784	800	816	mV
High Saturation Voltage	$V_{c,max}$		2.2	2.3		V
Low Saturation Voltage	$V_{c,min}$			0.001	0.3	V

CURRENT SENSE AMP

Common-Mode Range	CMR		3.1		40	V
Differential Mode Range	DMR		300			mV
Amplifier Gain	A_{csa}			2.0		V/V
Input Bias Current	$I_{sns,bias}$			30	50	μA

NCV885300

ELECTRICAL CHARACTERISTICS

($-40^{\circ}\text{C} < T_J < 150^{\circ}\text{C}$, $3.4\text{ V} < V_{IN} < 36\text{ V}$, $EN = 5\text{ V}$, no sync, unless otherwise specified)

Characteristic	Symbol	Conditions	Min	Typ	Max	Unit
----------------	--------	------------	-----	-----	-----	------

CURRENT LIMIT / OVER CURRENT PROTECTION

Cycle-by-Cycle Current Limit Threshold	V_{cl}		85	100	115	mV
Cycle-by-Cycle Current Limit Response Time	t_{cl}				200	nsec
Over Current Protection Threshold	V_{ocp}	% of V_d	125	150	175	%
Over Current Protection Response Time	t_{ocp}				200	ns

GATE DRIVERS

Leading Edge Blanking Time	$t_{on,min}$				100	ns
Gate Driver Pull Up Current	I_{sink}	$V_{IN} - V_{GDVR} = 4\text{ V}$		200	300	mA
Gate Driver Pull Down Current	I_{src}	$V_{IN} - V_{GDVR} = 4\text{ V}$		200	300	mA
Gate Driver Clamp Voltage ($V_{IN} - V_{GDVR}$)	V_{drv}		6.0	8.0	10	V
Power Switch Gate to Source Voltage	V_{gs}	$V_{IN} = 4\text{ V}$	3.8			V

SHORT CIRCUIT PROTECTION

Startup Blanking Time	$\%t_{scp,dly}$	From start of soft-start, percent of soft-start time	105		300	%
Short-Circuit Threshold Voltage	$\%V_{scp}$		65	70	75	%
Hiccup Time	$t_{hcp,dly}$	(% of Soft-Start Time)		135		%
SC Response Time	t_{scp}	Switcher Running		60	200	ns

THERMAL SHUTDOWN

Thermal Shutdown Threshold	T_{sd}	T_J rising	160	170	180	$^{\circ}\text{C}$
Thermal Shutdown Hysteresis	$T_{sd,hys}$	T_J Shutdown – T_J Startup	10	15	20	$^{\circ}\text{C}$
Thermal Shutdown Delay	t_{tsd}	$T_J >$ Thermal Shutdown Threshold to stop switching			200	ns

TYPICAL CHARACTERISTICS CURVES

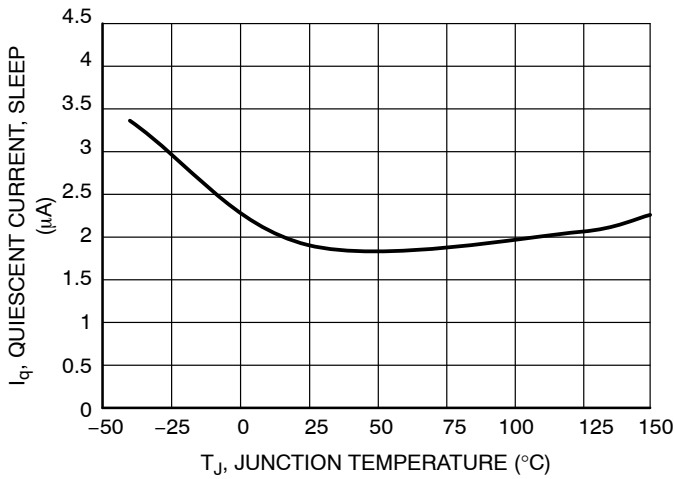

Figure 3. Quiescent Current (Sleep) vs. Junction Temperature

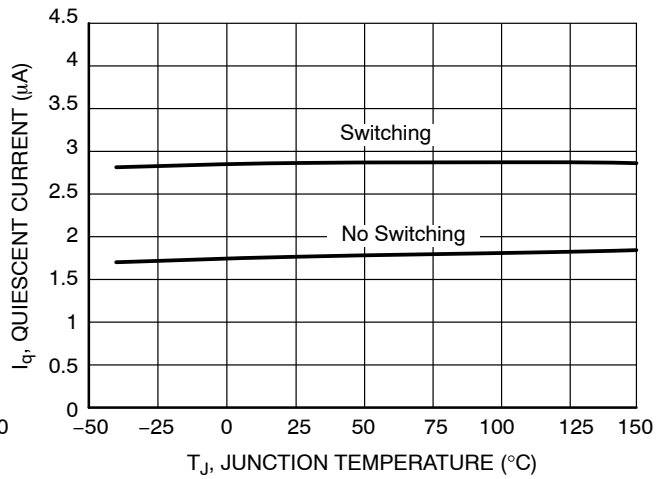

Figure 4. Quiescent Current vs. Junction Temperature

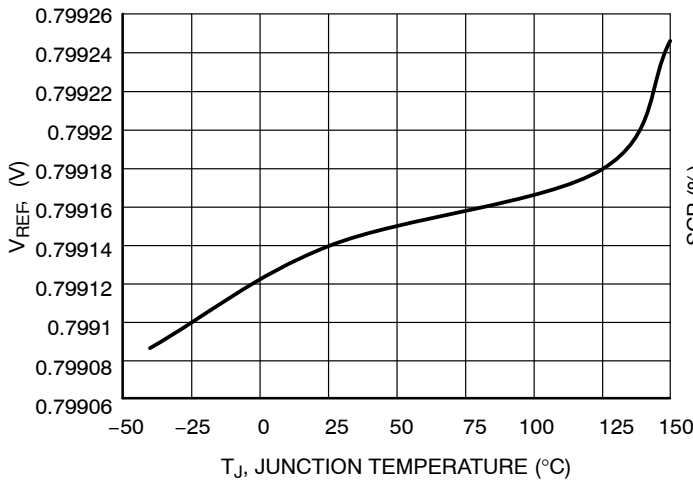

Figure 5. Reference Voltage vs. Junction Temperature

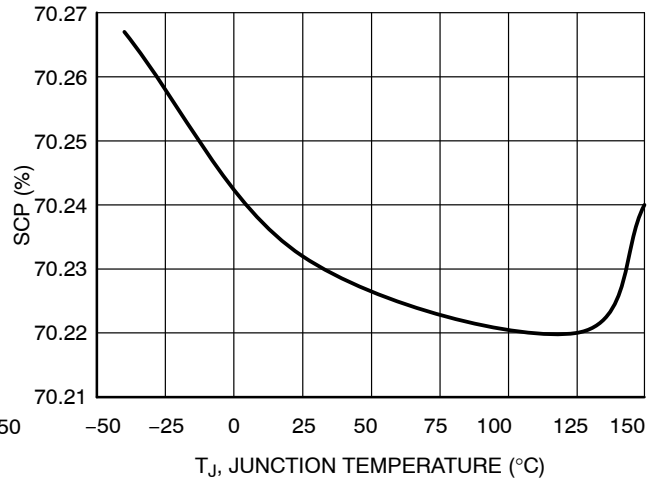

Figure 6. Short-Circuit Protection Threshold vs. Junction Temperature

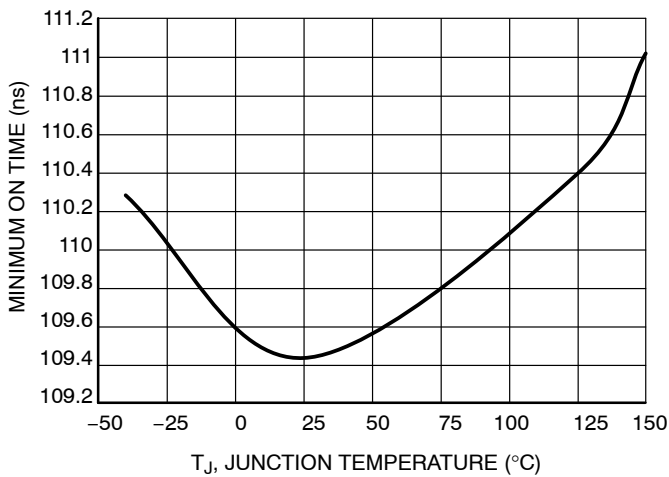

Figure 7. Minimum On Time vs. Junction Temperature

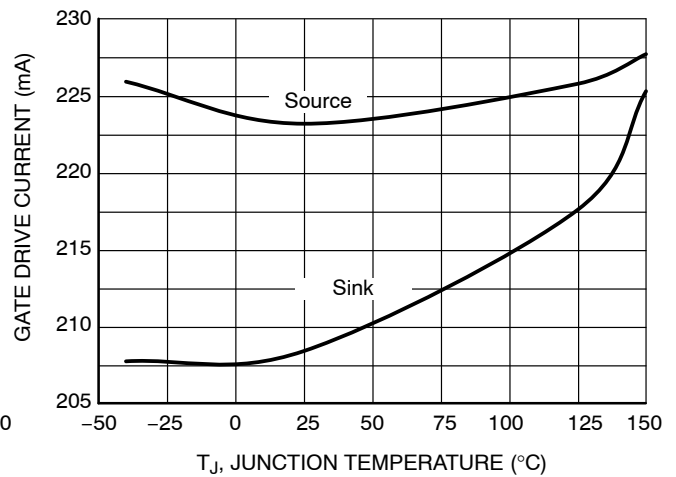

Figure 8. Gate Drive Current vs. Junction Temperature

TYPICAL CHARACTERISTICS CURVES

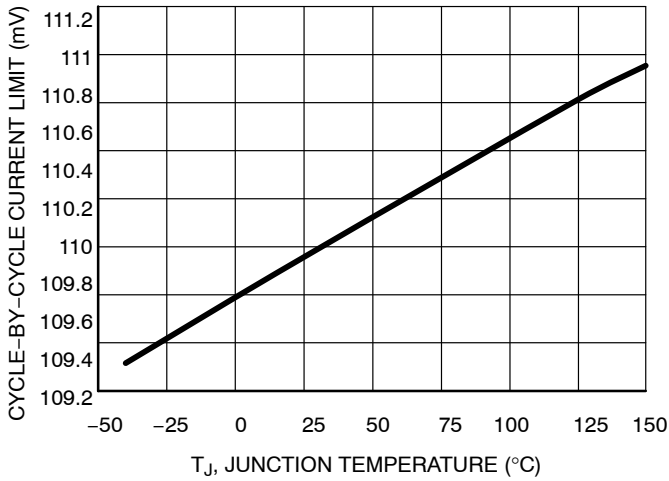

Figure 9. Cycle-by-Cycle Limit vs. Junction Temperature

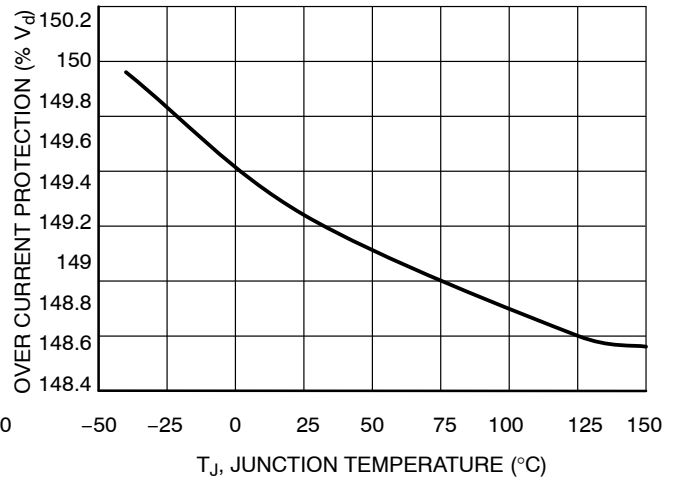

Figure 10. Over Current Protection vs. Junction Temperature

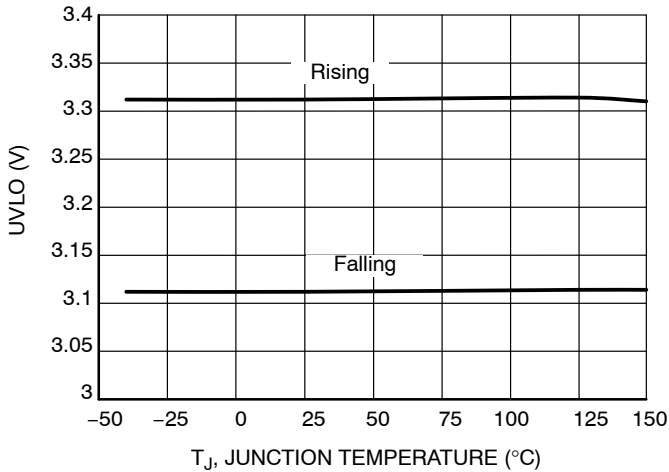

Figure 11. UVLO Threshold vs. Junction Temperature

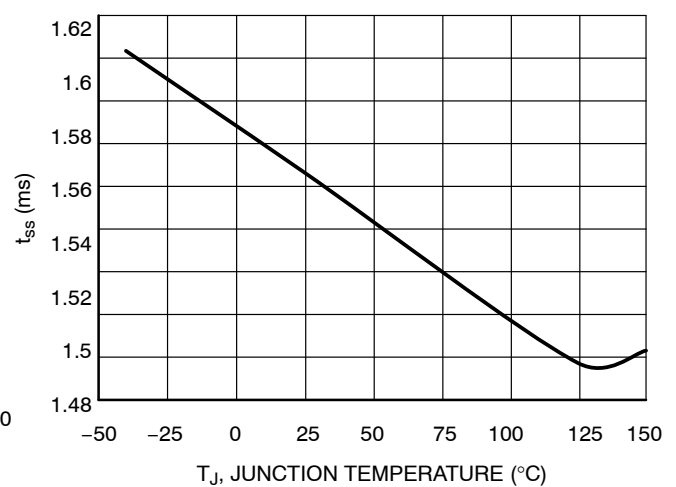

Figure 12. Soft-Start Time vs. Junction Temperature

THEORY OF OPERATION

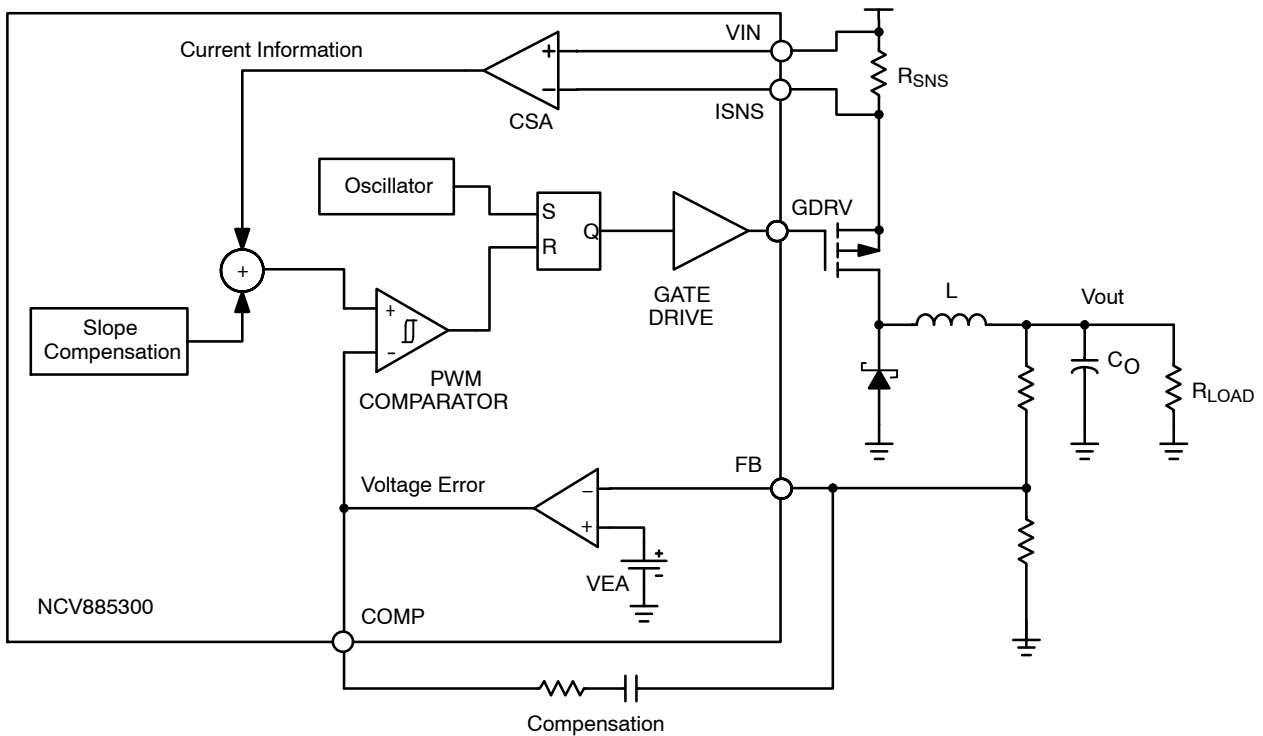

Figure 13. Current Mode Control Schematic

Current Mode Control

The NCV885300 SMPS incorporates a current mode control scheme, in which the PWM ramp signal is derived from the power switch current. This ramp signal is compared to the output of the error amplifier to control the on-time of the power switch. The oscillator is used as a fixed-frequency clock to ensure a constant operational frequency. The resulting control scheme features several advantages over conventional voltage mode control. First, derived from the resistor in the power path, the signal responds immediately to line voltage changes. This eliminates the delay caused by the output filter and error amplifier, which is commonly found in voltage mode controllers. The second benefit comes from inherent pulse-by-pulse current limiting by merely clamping the peak switching current. Finally, since current mode commands an output current rather than voltage, the filter offers only a single pole to the feedback loop. This allows for a simpler compensation.

The NCV885300 also includes a slope compensation scheme in which a fixed ramp generated by the oscillator is added to the current ramp. A proper slope rate is provided to improve circuit stability without sacrificing the advantages of current mode control.

Overcurrent Protection

The NCV885300 features two current limit protections: peak current mode and overcurrent hiccup mode. When the

current sense amplifier detects a voltage above the peak current limit between V_{IN} and $ISNS$ after the current limit leading edge blanking time, the peak current limit causes the power switch to turn off for the remainder of the cycle. Set the current limit with a resistor from V_{IN} to $ISNS$, with $R = 0.100 / I_{limit}$.

If the voltage across the current sense resistor exceeds the overcurrent threshold voltage the part enters overcurrent hiccup mode. The part will remain off for the hiccup time and then go through the power on reset procedure.

Short Circuit Hiccup Protection

When the output voltage falls below the short circuit trip voltage the part enters short circuit latch off. When a short is detected the NCV885300 disables the outputs and attempts to re-enable the outputs after the short circuit hiccup time. The part remains off for the hiccup time and then goes through the power on reset procedure. If the short has been removed then the output stage re-enables and operates normally; however, if the short is still present the cycle begins again. Internal heat dissipation is kept to a minimum as current will only flow during the reset time of the protection circuitry. The hiccup mode is continuous until the short is removed.

NCV885300

Gate Drive

To turn on the P-Channel MOSFET, the gate driver turns on a current source to ground. A clamp ensures that the gate drive voltage does not exceed 10 V. When the clamp starts conducting the current source starts to turn off. To turn off the external MOSFET, the gate driver turns on a current source to V_{IN} .

EN/SYNC

This pin has three modes. When a dc logic high (CMOS/TTL compatible) voltage is applied to this pin the NCV885300 operates at the default frequency. When a dc logic low voltage is applied to this pin the NCV885300 enters a low quiescent current sleep mode. When a square wave of at least 40% of the switching frequency is applied to this pin the switcher operates at the same frequency as the square wave. If the signal is slower than 40% of the switching frequency, it will be interpreted as enabling and disabling the part. The falling edge of the square wave corresponds to the start of the switching cycle.

Power Good

The power good pin is high when the reference voltage reaches 90% of its target of 800 mV. The pin should be pulled up with a 10 k Ω resistor to 5 V. The output voltage of the controller may be used in this case.

Overvoltage Lockout

To protect the IC, if the voltage on the VIN pin the exceeds V_{ovlo} the NCV885300 will shutdown. When the voltage drops below this voltage the part will go through the normal soft-start procedure.

Undervoltage Lockout

Undervoltage lockout protection is engaged when the input voltage drops below the V_{uvlo} signal. The part will remain off until the input voltage rises above the V_{uvlo} value plus hysteresis. Depending on the desired output voltage, it is possible to engage the short-circuit hiccup mode before undervoltage lockout occurs.

Soft-Start

To ensure moderate inrush current and reduce output overshoot, the NCV885300 features a soft start which periodically adds charge to a capacitor until the final reference voltage is achieved. When using an external SYNC signal, charging is based on the switching frequency. If, for example, the NCV885300 is synchronized to twice the free running (not synced) frequency, the soft-start will be half as long.

NCV885300

PACKAGE DIMENSIONS

SOIC-8 NB
CASE 751-07
ISSUE AK

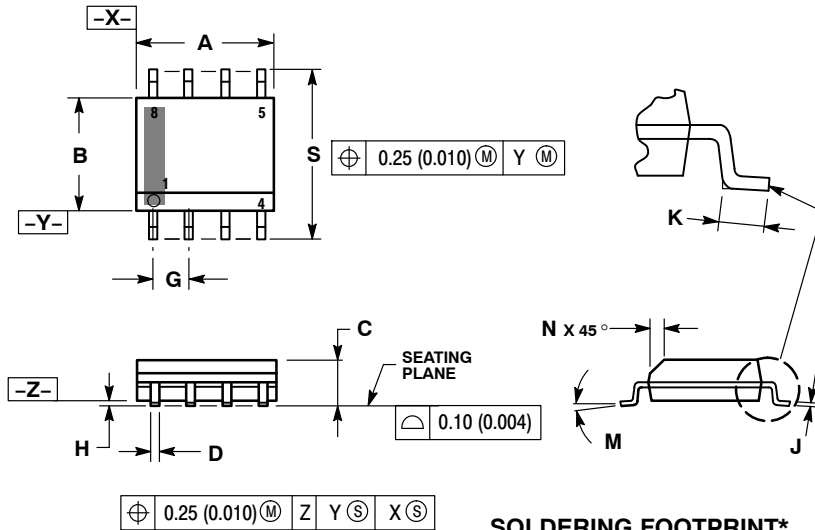

NOTES:

1. DIMENSIONING AND TOLERANCING PER ANSI Y14.5M, 1982.
2. CONTROLLING DIMENSION: MILLIMETER.
3. DIMENSION A AND B DO NOT INCLUDE MOLD PROTRUSION.
4. MAXIMUM MOLD PROTRUSION 0.15 (0.006) PER SIDE.
5. DIMENSION D DOES NOT INCLUDE DAMBAR PROTRUSION. ALLOWABLE DAMBAR PROTRUSION SHALL BE 0.127 (0.005) TOTAL IN EXCESS OF THE D DIMENSION AT MAXIMUM MATERIAL CONDITION.
6. 751-01 THRU 751-06 ARE OBSOLETE. NEW STANDARD IS 751-07.

DIM	MILLIMETERS		INCHES	
	MIN	MAX	MIN	MAX
A	4.80	5.00	0.189	0.197
B	3.80	4.00	0.150	0.157
C	1.35	1.75	0.053	0.069
D	0.33	0.51	0.013	0.020
G	1.27 BSC		0.050 BSC	
H	0.10	0.25	0.004	0.010
J	0.19	0.25	0.007	0.010
K	0.40	1.27	0.016	0.050
M	0° - 8°		0° - 8°	
N	0.25	0.50	0.010	0.020
S	5.80	6.20	0.228	0.244

SOLDERING FOOTPRINT*

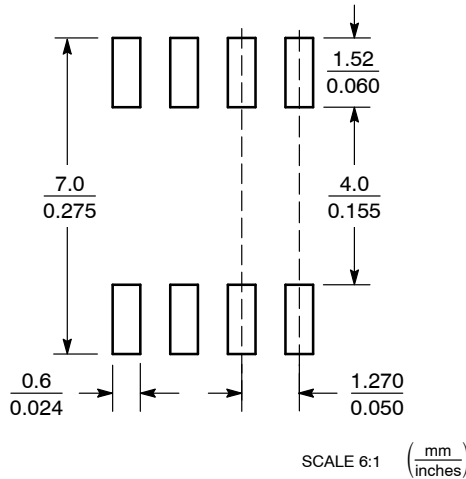

*For additional information on our Pb-Free strategy and soldering details, please download the ON Semiconductor Soldering and Mounting Techniques Reference Manual, SOLDERRM/D.

ON Semiconductor and are registered trademarks of Semiconductor Components Industries, LLC (SCILLC). SCILLC owns the rights to a number of patents, trademarks, copyrights, trade secrets, and other intellectual property. A listing of SCILLC's product/patent coverage may be accessed at www.onsemi.com/site/pdf/Patent-Marking.pdf. SCILLC reserves the right to make changes without further notice to any products herein. SCILLC makes no warranty, representation or guarantee regarding the suitability of its products for any particular purpose, nor does SCILLC assume any liability arising out of the application or use of any product or circuit, and specifically disclaims any and all liability, including without limitation special, consequential or incidental damages. "Typical" parameters which may be provided in SCILLC data sheets and/or specifications can and do vary in different applications and actual performance may vary over time. All operating parameters, including "Typicals" must be validated for each customer application by customer's technical experts. SCILLC does not convey any license under its patent rights nor the rights of others. SCILLC products are not designed, intended, or authorized for use as components in systems intended for surgical implant into the body, or other applications intended to support or sustain life, or for any other application in which the failure of the SCILLC product could create a situation where personal injury or death may occur. Should Buyer purchase or use SCILLC products for any such unintended or unauthorized application, Buyer shall indemnify and hold SCILLC and its officers, employees, subsidiaries, affiliates, and distributors harmless against all claims, costs, damages, and expenses, and reasonable attorney fees arising out of, directly or indirectly, any claim of personal injury or death associated with such unintended or unauthorized use, even if such claim alleges that SCILLC was negligent regarding the design or manufacture of the part. SCILLC is an Equal Opportunity/Affirmative Action Employer. This literature is subject to all applicable copyright laws and is not for resale in any manner.

PUBLICATION ORDERING INFORMATION

LITERATURE FULFILLMENT:
Literature Distribution Center for ON Semiconductor
P.O. Box 5163, Denver, Colorado 80217 USA
Phone: 303-675-2175 or 800-344-3860 Toll Free USA/Canada
Fax: 303-675-2176 or 800-344-3867 Toll Free USA/Canada
Email: orderlit@onsemi.com

N. American Technical Support: 800-282-9855 Toll Free
USA/Canada
Europe, Middle East and Africa Technical Support:
Phone: 421 33 790 2910
Japan Customer Focus Center
Phone: 81-3-5817-1050

ON Semiconductor Website: www.onsemi.com
Order Literature: <http://www.onsemi.com/orderlit>

For additional information, please contact your local Sales Representative

Компания «Океан Электроники» предлагает заключение долгосрочных отношений при поставках импортных электронных компонентов на взаимовыгодных условиях!

Наши преимущества:

- Поставка оригинальных импортных электронных компонентов напрямую с производств Америки, Европы и Азии, а так же с крупнейших складов мира;
- Широкая линейка поставок активных и пассивных импортных электронных компонентов (более 30 млн. наименований);
- Поставка сложных, дефицитных, либо снятых с производства позиций;
- Оперативные сроки поставки под заказ (от 5 рабочих дней);
- Экспресс доставка в любую точку России;
- Помощь Конструкторского Отдела и консультации квалифицированных инженеров;
- Техническая поддержка проекта, помощь в подборе аналогов, поставка прототипов;
- Поставка электронных компонентов под контролем ВП;
- Система менеджмента качества сертифицирована по Международному стандарту ISO 9001;
- При необходимости вся продукция военного и аэрокосмического назначения проходит испытания и сертификацию в лаборатории (по согласованию с заказчиком);
- Поставка специализированных компонентов военного и аэрокосмического уровня качества (Xilinx, Altera, Analog Devices, Intersil, Interpoint, Microsemi, Actel, Aeroflex, Peregrine, VPT, Syfer, Eurofarad, Texas Instruments, MS Kennedy, Miteq, Cobham, E2V, MA-COM, Hittite, Mini-Circuits, General Dynamics и др.);

Компания «Океан Электроники» является официальным дистрибьютором и эксклюзивным представителем в России одного из крупнейших производителей разъемов военного и аэрокосмического назначения «**JONHON**», а так же официальным дистрибьютором и эксклюзивным представителем в России производителя высокотехнологичных и надежных решений для передачи СВЧ сигналов «**FORSTAR**».



JONHON

«**JONHON**» (основан в 1970 г.)

Разъемы специального, военного и аэрокосмического назначения:

(Применяются в военной, авиационной, аэрокосмической, морской, железнодорожной, горно- и нефтедобывающей отраслях промышленности)

«**FORSTAR**» (основан в 1998 г.)

ВЧ соединители, коаксиальные кабели, кабельные сборки и микроволновые компоненты:

(Применяются в телекоммуникациях гражданского и специального назначения, в средствах связи, РЛС, а так же военной, авиационной и аэрокосмической отраслях промышленности).



Телефон: 8 (812) 309-75-97 (многоканальный)

Факс: 8 (812) 320-03-32

Электронная почта: ocean@oceanchips.ru

Web: <http://oceanchips.ru/>

Адрес: 198099, г. Санкт-Петербург, ул. Калинина, д. 2, корп. 4, лит. А