

## USB2532



# USB 2.0 Hi-Speed 2-Port Hub Controller

## PRODUCT FEATURES

Datasheet

### Highlights

- Hub Controller IC with 2 downstream ports
- USB-IF Battery Charger revision 1.2 support on up & downstream ports (DCP, CDP, SDP)
- Battery charging support for Apple<sup>®</sup> devices
- **FlexConnect**: Downstream port 1 able to swap with upstream port, allowing master capable devices to control other devices on the hub
- USB to I<sup>2</sup>C<sup>™</sup> bridge endpoint support
- USB Link Power Management (LPM) support
- SUSPEND pin for remote wakeup indication to host
- Vendor Specific Messaging (VSM) support
- Enhanced OEM configuration options available through a single serial I<sup>2</sup>C<sup>™</sup> EEPROM, OTP, or SMBus Slave Port
- 36-pin (6x6mm) SQFN, RoHS compliant package
- Footprint compatible with USB2512B

### Target Applications

- LCD monitors and TVs
- Multi-function USB peripherals
- PC mother boards
- Set-top boxes, DVD players, DVR/PVR
- Printers and scanners
- PC media drive bay
- Portable hub boxes
- Mobile PC docking
- Embedded systems

### Additional Features

- **MultiTRAK**<sup>™</sup>
  - Dedicated Transaction Translator per port
- **PortMap**
  - Configurable port mapping and disable sequencing
- **PortSwap**
  - Configurable differential intra-pair signal swapping
- **PHYBoost**<sup>™</sup>
  - Programmable USB transceiver drive strength for recovering signal integrity
- **VariSense**<sup>™</sup>
  - Programmable USB receiver sensitivity
- Low power operation
- Full Power Management with individual or ganged power control of each downstream port
- Built-in Self-Powered or Bus-Powered internal default settings provide flexibility in the quantity of USB expansion ports utilized without redesign
- Supports “Quad Page” configuration OTP flash
  - Four consecutive 200 byte configuration pages
- Fully integrated USB termination and Pull-up/Pull-down resistors
- On-chip Power On Reset (POR)
- Internal 3.3V and 1.2V voltage regulators
- On Board 24MHz Crystal Driver, Resonator, or External 24MHz clock input
- Environmental
  - Commercial temperature range support (0°C to 70°C)
  - Industrial temperature range support (-40°C to 85°C)

**Order Number(s):**

ORDER NUMBER	TEMPERATURE RANGE	PACKAGE TYPE
USB2532-1080AEN	0°C to +70°C	36-pin SQFN
USB2532-1080AEN-TR	0°C to +70°C	36-pin SQFN (Tape & Reel)
USB2532i-1080AEN	-40°C to +85°C	36-pin SQFN
USB2532i-1080AENTR	-40°C to +85°C	36-pin SQFN (Tape & Reel)

**This product meets the halogen maximum concentration values per IEC61249-2-21**

**For RoHS compliance and environmental information, please visit [www.smsc.com/rohs](http://www.smsc.com/rohs)**

*Please contact your SMSC sales representative for additional documentation related to this product such as application notes, anomaly sheets, and design guidelines.*

**The table above represents valid part numbers at the time of printing and may not represent parts that are currently available. For the latest list of valid ordering numbers for this product, please contact the nearest sales office.**

Copyright © 2013 SMSC or its subsidiaries. All rights reserved.

Circuit diagrams and other information relating to SMSC products are included as a means of illustrating typical applications. Consequently, complete information sufficient for construction purposes is not necessarily given. Although the information has been checked and is believed to be accurate, no responsibility is assumed for inaccuracies. SMSC reserves the right to make changes to specifications and product descriptions at any time without notice. Contact your local SMSC sales office to obtain the latest specifications before placing your product order. The provision of this information does not convey to the purchaser of the described semiconductor devices any licenses under any patent rights or other intellectual property rights of SMSC or others. All sales are expressly conditional on your agreement to the terms and conditions of the most recently dated version of SMSC's standard Terms of Sale Agreement dated before the date of your order (the "Terms of Sale Agreement"). The product may contain design defects or errors known as anomalies which may cause the product's functions to deviate from published specifications. Anomaly sheets are available upon request. SMSC products are not designed, intended, authorized or warranted for use in any life support or other application where product failure could cause or contribute to personal injury or severe property damage. Any and all such uses without prior written approval of an Officer of SMSC and further testing and/or modification will be fully at the risk of the customer. Copies of this document or other SMSC literature, as well as the Terms of Sale Agreement, may be obtained by visiting SMSC's website at <http://www.smsc.com>. SMSC is a registered trademark of Standard Microsystems Corporation ("SMSC"). Product names and company names are the trademarks of their respective holders.

The Microchip name and logo, and the Microchip logo are registered trademarks of Microchip Technology Incorporated in the U.S.A. and other countries.

**SMSC DISCLAIMS AND EXCLUDES ANY AND ALL WARRANTIES, INCLUDING WITHOUT LIMITATION ANY AND ALL IMPLIED WARRANTIES OF MERCHANTABILITY, FITNESS FOR A PARTICULAR PURPOSE, TITLE, AND AGAINST INFRINGEMENT AND THE LIKE, AND ANY AND ALL WARRANTIES ARISING FROM ANY COURSE OF DEALING OR USAGE OF TRADE. IN NO EVENT SHALL SMSC BE LIABLE FOR ANY DIRECT, INCIDENTAL, INDIRECT, SPECIAL, PUNITIVE, OR CONSEQUENTIAL DAMAGES; OR FOR LOST DATA, PROFITS, SAVINGS OR REVENUES OF ANY KIND; REGARDLESS OF THE FORM OF ACTION, WHETHER BASED ON CONTRACT; TORT; NEGLIGENCE OF SMSC OR OTHERS; STRICT LIABILITY; BREACH OF WARRANTY; OR OTHERWISE; WHETHER OR NOT ANY REMEDY OF BUYER IS HELD TO HAVE FAILED OF ITS ESSENTIAL PURPOSE, AND WHETHER OR NOT SMSC HAS BEEN ADVISED OF THE POSSIBILITY OF SUCH DAMAGES.**

## Table of Contents

<b>Chapter 1 General Description</b> .....	<b>7</b>
1.1 Block Diagram .....	8
<b>Chapter 2 Acronyms and Definitions</b> .....	<b>9</b>
2.1 Acronyms .....	9
2.2 Reference Documents .....	9
<b>Chapter 3 Pin Descriptions</b> .....	<b>10</b>
3.1 Pin Descriptions .....	11
3.2 Pin Assignments .....	18
3.3 Buffer Type Descriptions .....	19
<b>Chapter 4 Power Connections</b> .....	<b>20</b>
4.1 Integrated Power Regulators .....	20
4.2 Power Connection Diagrams .....	20
<b>Chapter 5 Modes of Operation</b> .....	<b>21</b>
5.1 Boot Sequence .....	23
5.1.1 Standby Mode .....	23
5.1.2 Hardware Initialization Stage (HW_INIT) .....	23
5.1.3 Software Initialization Stage (SW_INIT) .....	23
5.1.4 SOC Configuration Stage (SOC_CFG) .....	23
5.1.5 Configuration Stage (CONFIG) .....	23
5.1.6 Battery Charger Detection Stage (CHGDET) .....	24
5.1.7 Hub Connect Stage (Hub.Connect) .....	24
5.1.8 Normal Mode .....	24
<b>Chapter 6 Device Configuration</b> .....	<b>25</b>
6.1 Configuration Method Selection .....	25
6.2 Customer Accessible Functions .....	25
6.2.1 USB Accessible Functions .....	26
6.2.2 SMBus Accessible Functions .....	27
6.3 Device Configuration Straps .....	28
6.3.1 Non-Removable Device (NON_REM[1:0]) .....	28
6.3.2 Configuration Select (CFG_SEL[1:0]) .....	28
6.3.3 Downstream Battery Charging Enable (BC_EN[2:1]) .....	28
6.3.4 Port Disable (PRT_DIS_Mx/PRT_DIS_Px) .....	29
<b>Chapter 7 Device Interfaces</b> .....	<b>30</b>
7.1 I2C Master Interface .....	30
7.1.1 I2C Message Format .....	30
7.1.2 Pull-Up Resistors for I2C .....	31
7.2 SMBus Slave Interface .....	31
7.2.1 SMBus Run Time Accessible Registers .....	31
7.2.2 Run Time SMBus Page Register .....	43
<b>Chapter 8 Functional Descriptions</b> .....	<b>44</b>

8.1 Battery Charger Detection & Charging	44
8.1.1 Upstream Battery Charger Detection	44
8.1.2 Downstream Battery Charging	45
8.2 Flex Connect	47
8.2.1 Port Control	47
8.3 Resets	47
8.3.1 Power-On Reset (POR)	47
8.3.2 External Chip Reset (RESET_N)	47
8.3.3 USB Bus Reset	48
8.4 Link Power Management (LPM)	48
8.5 Remote Wakeup Indicator (SUSP_IND)	48
8.5.1 Normal Resume Behavior	49
8.5.2 Modified Resume Behavior	49
8.6 High Speed Indicator (HS_IND)	50
<hr/>	
<b>Chapter 9 Operational Characteristics</b>	<b>51</b>
9.1 Absolute Maximum Ratings*	51
9.2 Operating Conditions**	52
9.3 Power Consumption	53
9.3.1 Operational / Unconfigured	53
9.3.2 Suspend / Standby	53
9.4 DC Specifications	54
9.5 AC Specifications	55
9.5.1 Power-On Configuration Strap Valid Timing	55
9.5.2 Reset and Configuration Strap Timing	56
9.5.3 USB Timing	56
9.5.4 SMBus Timing	56
9.5.5 I2C Timing	56
9.6 Clock Specifications	57
9.6.1 Oscillator/Crystal	57
9.6.2 External Reference Clock (REFCLK)	57
<hr/>	
<b>Chapter 10 Package Outline</b>	<b>58</b>
<hr/>	
<b>Chapter 11 Datasheet Revision History</b>	<b>60</b>

## List of Figures

Figure 1.1	System Block Diagram . . . . .	8
Figure 3.1	36-SQFN Pin Assignments . . . . .	10
Figure 4.1	Power Connections . . . . .	20
Figure 5.1	Hub Operational Mode Flowchart . . . . .	22
Figure 7.1	I2C Sequential Access Write Format . . . . .	30
Figure 7.2	I2C Sequential Access Read Format . . . . .	31
Figure 8.1	Battery Charging External Power Supply . . . . .	45
Figure 9.1	Supply Rise Time Model . . . . .	52
Figure 9.2	Power-On Configuration Strap Valid Timing . . . . .	55
Figure 9.3	RESET_N Configuration Strap Timing . . . . .	56
Figure 10.1	36-SQFN Package Drawing . . . . .	58
Figure 10.2	36-SQFN Package Recommended Land Pattern . . . . .	59

## List of Tables

Table 3.1	Pin Descriptions	11
Table 3.2	36-SQFN Package Pin Assignments	18
Table 3.3	Buffer Types	19
Table 6.1	Hub Configuration Selection	25
Table 6.2	NON_REM[1:0] Configuration Definitions	28
Table 6.3	PRT_DIS_Mx/PRT_DIS_Px Configuration Definitions	29
Table 7.1	SMBus Accessible Run Time Registers	32
Table 7.2	Upstream Battery Charging Detection Control Register	33
Table 7.3	Upstream Custom Battery Charger Control Register	34
Table 7.4	Upstream Custom Battery Charger Status Register	35
Table 7.5	Port Power Status Register	35
Table 7.6	OCS Status Register	36
Table 7.7	Upstream Battery Charger Mode Register	36
Table 7.8	Charge Detect Mask Register	37
Table 7.9	Configure Portable Hub Register	38
Table 7.10	Port Select and Low-Power Suspend Register	38
Table 7.11	Connect Configuration Register	39
Table 7.12	Upstream (Port 0) Battery Charging Control 1 Register	40
Table 7.13	Upstream (Port 0) Battery Charging Control 2 Register	41
Table 7.14	Upstream (Port 0) Battery Charging Run Time Control Register	42
Table 7.15	Upstream (Port 0) Battery Charging Detect Register	42
Table 7.16	SMBus Page Register	43
Table 8.1	Chargers Compatible with Upstream Detection	44
Table 8.2	Downstream Port Types	46
Table 8.3	LPM State Definitions	48
Table 9.1	Operational/Unconfigured Power Consumption	53
Table 9.2	Suspend/Standby Power Consumption	53
Table 9.3	DC Electrical Characteristics	54
Table 9.4	Power-On Configuration Strap Valid Timing	55
Table 9.5	RESET_N Configuration Strap Timing	56
Table 9.6	Crystal Specifications	57
Table 10.1	36-SQFN Package Dimensions	58
Table 11.1	Revision History	60

## Chapter 1 General Description

The SMSC USB2532 is a low-power, OEM configurable, MTT (Multi-Transaction Translator) USB 2.0 hub controller with 2 downstream ports and advanced features for embedded USB applications. The USB2532 is fully compliant with the USB 2.0 Specification, USB 2.0 Link Power Management Addendum and will attach to an upstream port as a Full-Speed hub or as a Full-/Hi-Speed hub. The 2-port hub supports Low-Speed, Full-Speed, and Hi-Speed (if operating as a Hi-Speed hub) downstream devices on all of the enabled downstream ports.

The USB2532 has been specifically optimized for embedded systems where high performance, and minimal BOM costs are critical design requirements. Standby mode power has been minimized and reference clock inputs can be aligned to the customer's specific application. Additionally, all required resistors on the USB ports are integrated into the hub, including all series termination and pull-up/pull-down resistors on the D+ and D- pins.

The USB2532 supports both upstream battery charger detection and downstream battery charging. The USB2532 integrated battery charger detection circuitry supports the USB-IF Battery Charging (BC1.2) detection method and most Apple devices. These circuits are used to detect the attachment and type of a USB charger and provide an interrupt output to indicate charger information is available to be read from the device's status registers via the serial interface. The USB2532 provides the battery charging handshake and supports the following USB-IF BC1.2 charging profiles:

- DCP: Dedicated Charging Port (Power brick with no data)
- CDP: Charging Downstream Port (1.5A with data)
- SDP: Standard Downstream Port (0.5A with data)
- Custom profiles loaded via SMBus or OTP

The USB2532 provides an additional USB endpoint dedicated for use as a USB to I<sup>2</sup>C interface, allowing external circuits or devices to be monitored, controlled, or configured via the USB interface. Additionally, the USB2532 includes many powerful and unique features such as:

**FlexConnect**, which provides flexible connectivity options. The USB2532's downstream port 1 can be swapped with the upstream port, allowing master capable devices to control other devices on the hub.

**MultiTRAK™ Technology**, which utilizes a dedicated Transaction Translator (TT) per port to maintain consistent full-speed data throughput regardless of the number of active downstream connections. MultiTRAK™ outperforms conventional USB 2.0 hubs with a single TT in USB full-speed data transfers.

**PortMap**, which provides flexible port mapping and disable sequences. The downstream ports of a USB2532 hub can be reordered or disabled in any sequence to support multiple platform designs with minimum effort. For any port that is disabled, the USB2532 hub controllers automatically reorder the remaining ports to match the USB host controller's port numbering scheme.

**PortSwap**, which adds per-port programmability to USB differential-pair pin locations. PortSwap allows direct alignment of USB signals (D+/D-) to connectors to avoid uneven trace length or crossing of the USB differential signals on the PCB.

**PHYBoost**, which provides programmable levels of Hi-Speed USB signal drive strength in the downstream port transceivers. PHYBoost attempts to restore USB signal integrity in a compromised system environment. The graphic on the right shows an example of Hi-Speed USB eye diagrams before and after PHYBoost signal integrity restoration.



**VariSense**, which controls the USB receiver sensitivity enabling programmable levels of USB signal receive sensitivity. This capability allows operation in a sub-optimal system environment, such as when a captive USB cable is used.

The USB2532 is available in commercial (0°C to +70°C) and industrial (-40°C to +85°C) temperature range versions.

# 1.1 Block Diagram

Figure 1.1 details the internal block diagram of the USB2532.

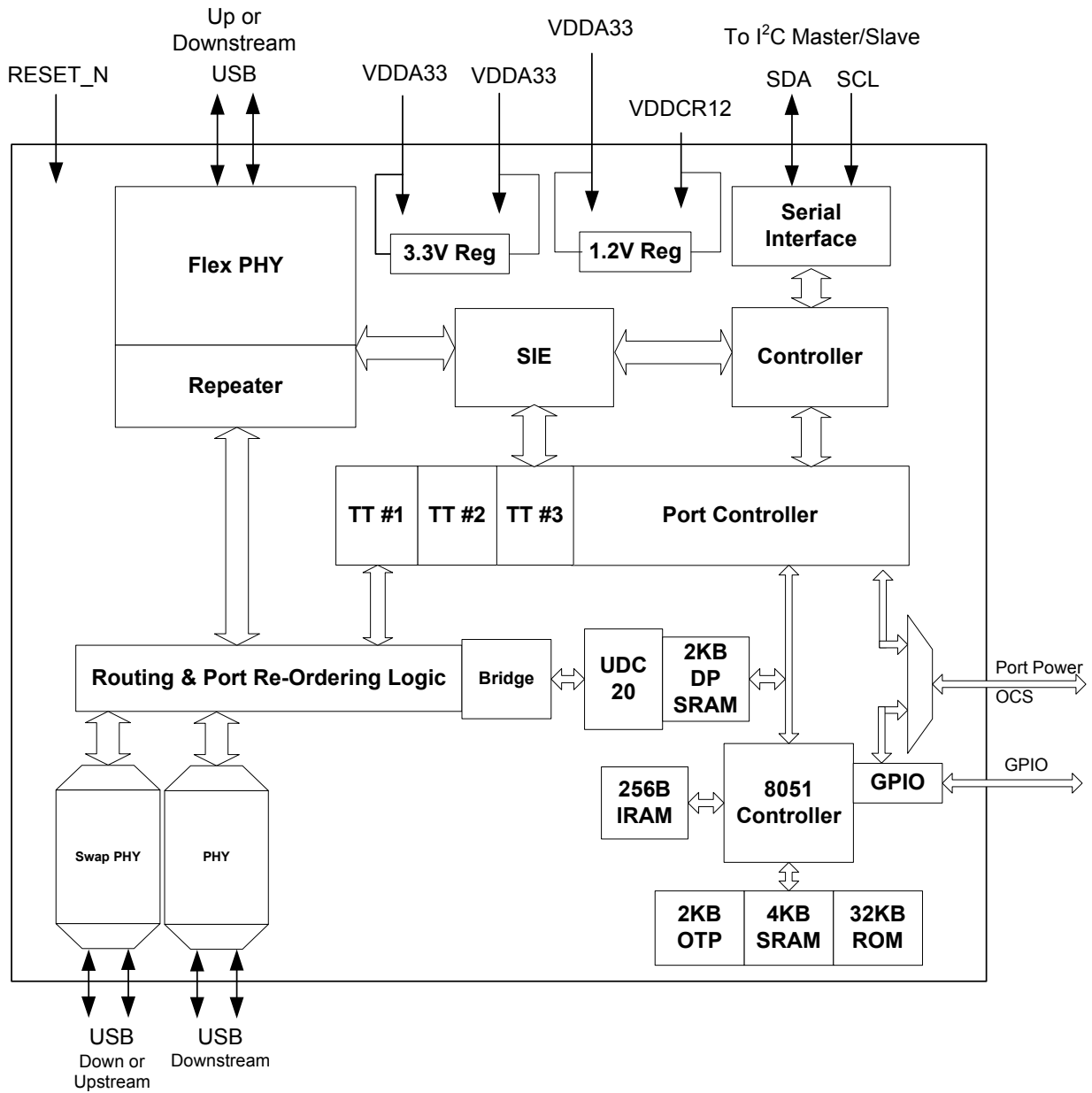

Figure 1.1 System Block Diagram



## Chapter 2 Acronyms and Definitions

### 2.1 Acronyms

<b>EOP:</b>	End of Packet
<b>EP:</b>	Endpoint
<b>FS:</b>	Full-Speed
<b>GPIO:</b>	General Purpose I/O (that is input/output to/from the device)
<b>HS:</b>	Hi-Speed
<b>HSOS:</b>	High Speed Over Sampling
<b>I<sup>2</sup>C<sup>®</sup>:</b>	Inter-Integrated Circuit
<b>LS:</b>	Low-Speed
<b>OTP:</b>	One Time Programmable
<b>PCB:</b>	Printed Circuit Board
<b>PCS:</b>	Physical Coding Sublayer
<b>PHY:</b>	Physical Layer
<b>SMBus:</b>	System Management Bus
<b>UUID:</b>	Universally Unique IDentification

### 2.2 Reference Documents

1. *UNICODE UTF-16LE For String Descriptors* USB Engineering Change Notice, December 29th, 2004, <http://www.usb.org>
2. *Universal Serial Bus Specification*, Revision 2.0, April 27th, 2000, <http://www.usb.org>
3. *Battery Charging Specification*, Revision 1.2, Dec. 07, 2010, <http://www.usb.org>
4. *I<sup>2</sup>C-Bus Specification*, Version 1.1, <http://www.nxp.com>
5. *System Management Bus Specification*, Version 1.0, <http://smbus.org/specs>

**SMSC MAKES NO WARRANTIES, EXPRESS, IMPLIED, OR STATUTORY, IN REGARD TO INFRINGEMENT OR OTHER VIOLATION OF INTELLECTUAL PROPERTY RIGHTS. SMSC DISCLAIMS AND EXCLUDES ANY AND ALL WARRANTIES AGAINST INFRINGEMENT AND THE LIKE.**

No license is granted by SMSC expressly, by implication, by estoppel or otherwise, under any patent, trademark, copyright, mask work right, trade secret, or other intellectual property right. \*\*To obtain this software program the appropriate SMSC Software License Agreement must be executed and in effect. Forms of these Software License Agreements may be obtained by contacting SMSC.

## Chapter 3 Pin Descriptions

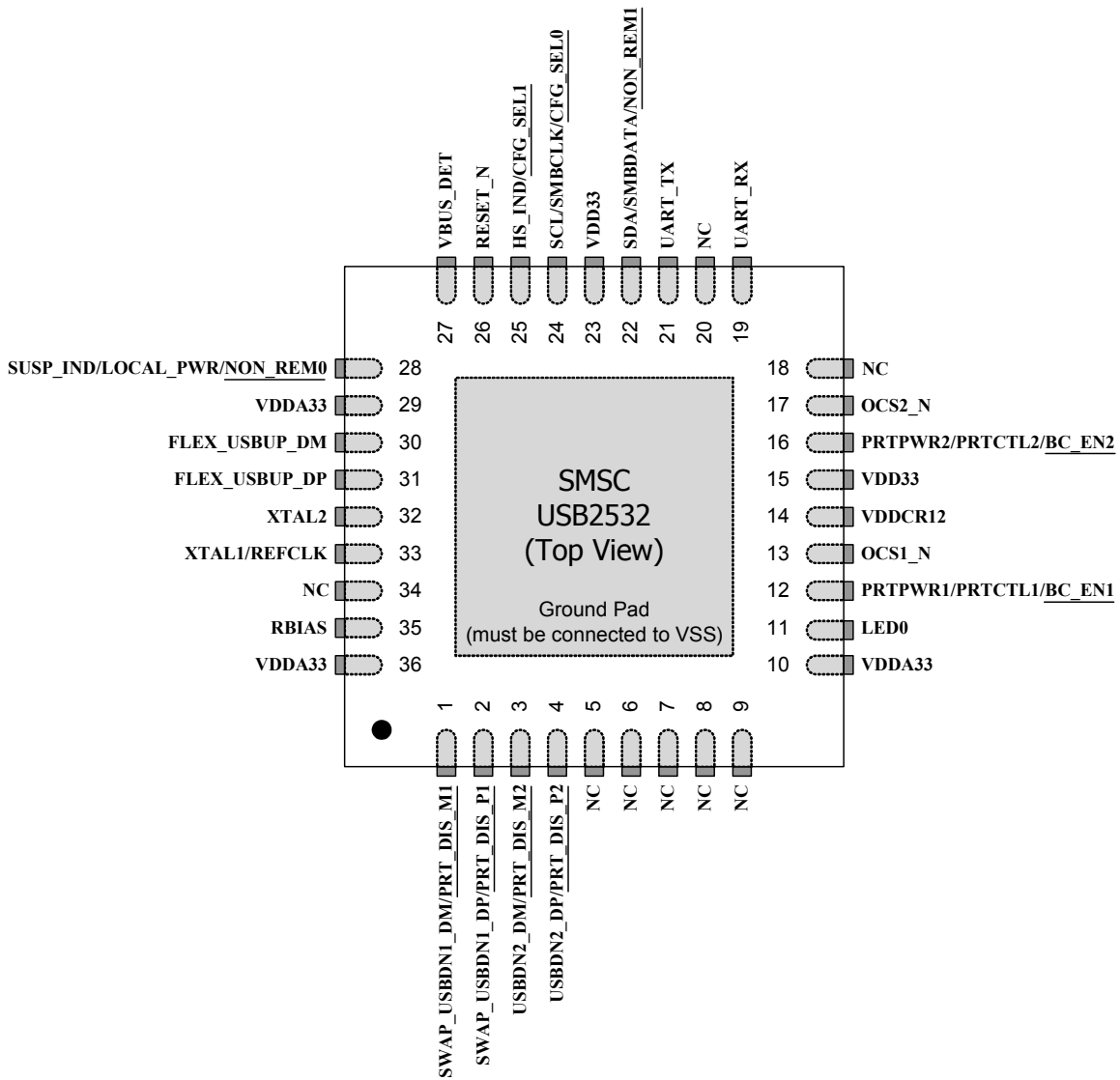

Figure 3.1 36-SQFN Pin Assignments

### 3.1 Pin Descriptions

This section provides a detailed description of each pin. The signals are arranged in functional groups according to their associated interface.

The “\_N” symbol in the signal name indicates that the active, or asserted, state occurs when the signal is at a low voltage level. For example, RESET\_N indicates that the reset signal is active low. When “\_N” is not present after the signal name, the signal is asserted when at the high voltage level.

The terms assertion and negation are used exclusively. This is done to avoid confusion when working with a mixture of “active low” and “active high” signals. The term assert, or assertion, indicates that a signal is active, independent of whether that level is represented by a high or low voltage. The term negate, or negation, indicates that a signal is inactive.

**Note:** The buffer type for each signal is indicated in the BUFFER TYPE column of [Table 3.1](#). A description of the buffer types is provided in [Section 3.3](#).

**Note:** Compatibility with the SMSC UCS100x family of USB port power controllers requires the UCS100x be connected on Port 1 of the USB2532. Additionally, both PRT\_PWR1 and OCS1\_N must be pulled high at Power-On Reset (POR).

**Table 3.1 Pin Descriptions**

NUM PINS	NAME	SYMBOL	BUFFER TYPE	DESCRIPTION
<b>USB/HSIC INTERFACES</b>				
1	Upstream USB D+ (Flex Port 0)	FLEX_USBUP_DP	AIO	Upstream USB Port 0 D+ data signal. <b>Note:</b> The upstream Port 0 signals can be optionally swapped with the downstream Port 1 signals.
1	Upstream USB D- (Flex Port 0)	FLEX_USBUP_DM	AIO	Upstream USB Port 0 D- data signal. <b>Note:</b> The upstream Port 0 signals can be optionally swapped with the downstream Port 1 signals.
1	Downstream USB D+ (Swap Port 1)	SWAP_USBDN1_DP	AIO	Downstream USB Port 1 D+ data signal. <b>Note:</b> The downstream Port 1 signals can be optionally swapped with the upstream Port 0 signals.
	Port 1 D+ Disable Configuration Strap	<u>PRT_DIS_P1</u>	IS	This strap is used in conjunction with <u>PRT_DIS_M1</u> to disable USB Port 1. 0 = Port 1 D+ Enabled 1 = Port 1 D+ Disabled <b>Note:</b> Both <u>PRT_DIS_P1</u> and <u>PRT_DIS_M1</u> must be tied to VDD33 at reset to disable the associated port. See <a href="#">Note 3.4</a> for more information on configuration straps.

Table 3.1 Pin Descriptions (continued)

NUM PINS	NAME	SYMBOL	BUFFER TYPE	DESCRIPTION
1	Downstream USB D- (Swap Port 1)	SWAP_USBDN1_DM	AIO	Downstream USB Port 1 D- data signal. <b>Note:</b> The downstream Port 1 signals can be optionally swapped with the upstream Port 0 signals.
	Port 1 D- Disable Configuration Strap	<u>PRT_DIS_M1</u>	IS	This strap is used in conjunction with <u>PRT_DIS_P1</u> to disable USB Port 1.  0 = Port 1 D- Enabled 1 = Port 1 D- Disabled <b>Note:</b> Both <u>PRT_DIS_P1</u> and <u>PRT_DIS_M1</u> must be tied to VDD33 at reset to disable the associated port. See <a href="#">Note 3.4</a> for more information on configuration straps.
1	Downstream USB D+ (Port 2)	USBDN2_DP	AIO	Downstream USB Port 2 D+ data signal.
	Port 2 D+ Disable Configuration Strap	<u>PRT_DIS_P2</u>	IS	This strap is used in conjunction with <u>PRT_DIS_M2</u> to disable USB Port 2.  0 = Port 2 D+ Enabled 1 = Port 2 D+ Disabled <b>Note:</b> Both <u>PRT_DIS_P2</u> and <u>PRT_DIS_M2</u> must be tied to VDD33 at reset to disable the associated port. See <a href="#">Note 3.4</a> for more information on configuration straps.
1	Downstream USB D- (Port 2)	USBDN2_DM	AIO	Downstream USB Port 2 D- data signal.
	Port 2 D- Disable Configuration Strap	<u>PRT_DIS_M2</u>	IS	This strap is used in conjunction with <u>PRT_DIS_P2</u> to disable USB Port 2.  0 = Port 2 D- Enabled 1 = Port 2 D- Disabled <b>Note:</b> Both <u>PRT_DIS_P2</u> and <u>PRT_DIS_M2</u> must be tied to VDD33 at reset to disable the associated port. See <a href="#">Note 3.4</a> for more information on configuration straps.

Table 3.1 Pin Descriptions (continued)

NUM PINS	NAME	SYMBOL	BUFFER TYPE	DESCRIPTION
<b>I<sup>2</sup>C/SMBUS INTERFACE</b>				
1	I <sup>2</sup> C Serial Clock Input	SCL	I_SMB	I <sup>2</sup> C serial clock input
	SMBus Clock	SMBCLK	I_SMB	SMBus serial clock input
	Configuration Select 0 Configuration Strap	<u>CFG_SEL0</u>	I_SMB	This strap is used in conjunction with <u>CFG_SEL1</u> to set the hub configuration method. Refer to <a href="#">Section 6.3.2, "Configuration Select (CFG_SEL[1:0])"</a> , on page 28 for additional information.  See <a href="#">Note 3.4</a> for more information on configuration straps.
1	I <sup>2</sup> C Serial Data	SDA	IS/OD8	I <sup>2</sup> C bidirectional serial data
	SMBus Serial Data	SMBDATA	IS/OD8	SMBus bidirectional serial data
	Non-Removable Device 1 Configuration Strap	<u>NON_REM1</u> ( <a href="#">Note 3.3</a> )	IS	This strap is used in conjunction with <u>NON_REM0</u> to configure the downstream ports as non-removable devices. Refer to <a href="#">Section 6.3.1, "Non-Removable Device (NON_REM[1:0])"</a> , on page 28 for additional information.  See <a href="#">Note 3.4</a> for more information on configuration straps.
<b>MISC.</b>				
1	Port 1 Over-Current Sense Input	OCS1_N	IS (PU)	This active-low signal is input from an external current monitor to indicate an over-current condition on USB Port 1.
1	Port 2 Over-Current Sense Input	OCS2_N	IS (PU)	This active-low signal is input from an external current monitor to indicate an over-current condition on USB Port 2.
1	UART Receive Input	UART_RX	IS	Internal UART receive input <b>Note:</b> This is a 3.3V signal. For RS232 operation, an external 12V translator is required.
1	UART Transmit Output	UART_TX	O8	Internal UART transmit output <b>Note:</b> This is a 3.3V signal. For RS232 operation, an external 12V driver is required.

Table 3.1 Pin Descriptions (continued)

NUM PINS	NAME	SYMBOL	BUFFER TYPE	DESCRIPTION
1	System Reset Input	RESET_N	I_RST	This active-low signal allows external hardware to reset the device. <b>Note:</b> The active-low pulse must be at least 5 $\mu$ s wide. Refer to <a href="#">Section 8.3.2, "External Chip Reset (RESET_N),"</a> on <a href="#">page 47</a> for additional information.
1	Crystal Input	XTAL1	ICLK	External 24 MHz crystal input
	Reference Clock Input	REFCLK	ICLK	Reference clock input. The device may be alternatively driven by a single-ended clock oscillator. When this method is used, XTAL2 should be left unconnected.
1	Crystal Output	XTAL2	OCLK	External 24 MHz crystal output
1	External USB Transceiver Bias Resistor	RBIAS	AI	A 12.0k $\Omega$ (+/- 1%) resistor is attached from ground to this pin to set the transceiver's internal bias settings.
1	LED 0 Output	LED0	O8	General purpose LED 0 output that is configurable to blink or "breathe" at various rates. <b>Note:</b> LED0 must be enabled via the Protouch configuration tool.
1	Detect Upstream VBUS Power	VBUS_DET	IS	<p>Detects state of upstream bus power.</p> <p>When designing a detachable hub, this pin must be connected to the VBUS power pin of the upstream USB port through a resistor divider (50k<math>\Omega</math> by 100k<math>\Omega</math>) to provide 3.3V.</p> <p>For self-powered applications with a permanently attached host, this pin must be connected to either 3.3V or 5.0V through a resistor divider to provide 3.3V.</p> <p>In embedded applications, VBUS_DET may be controlled (toggled) when the host desires to renegotiate a connection without requiring a full reset of the device.</p>

Table 3.1 Pin Descriptions (continued)

NUM PINS	NAME	SYMBOL	BUFFER TYPE	DESCRIPTION
1	Remote Wakeup Indicator	SUSP_IND	OD8	<p>Configurable sideband signal used to indicate Suspend status (default) or Remote Wakeup events to the Host.</p> <p>Suspend Indicator (default configuration):            0 = Unconfigured, or configured and in USB suspend mode            1 = Device is configured and is active (i.e., not in suspend)</p> <p>For Remote Wakeup Indicator mode:            Refer to <a href="#">Section 8.5, "Remote Wakeup Indicator (SUSP_IND),"</a> on page 48.</p> <p>Refer to <a href="#">Section 6.3.1, "Non-Removable Device (NON_REM[1:0]),"</a> on page 28 for information on LED polarity when using this signal.</p>
	Local Power Detect	LOCAL_PWR	IS	<p>Detects the availability of a local self-power source.</p> <p>0 = Self/local power source is NOT available. (i.e., device must obtain all power from upstream USB VBUS)            1 = Self/local power source is available</p> <p>See <a href="#">Note 3.2</a> for more information on this pin.</p>
	Non-Removable Device 0 Configuration Strap	<u>NON_REM0</u> ( <a href="#">Note 3.3</a> )	IS	<p>This strap is used in conjunction with <u>NON_REM1</u> to configure the downstream ports as non-removable devices. Refer to <a href="#">Section 6.3.1, "Non-Removable Device (NON_REM[1:0]),"</a> on page 28 for additional information.</p> <p>See <a href="#">Note 3.4</a> for more information on configuration straps.</p>
1	High Speed Indicator	HS_IND	O8	<p>Indicates a high speed connection on the upstream port. The active state of the LED will be determined as follows:</p> <p>If CFG_SEL1 = 0, HS_IND is active high.            If CFG_SEL1 = 1, HS_IND is active low.</p> <p>Asserted = hub is connected at high speed            Negated = Hub is connected at full speed</p>
	Configuration Select 1 Configuration Strap	<u>CFG_SEL1</u>	IS	<p>This strap is used in conjunction with <u>CFG_SEL0</u> to set the hub configuration method. Refer to <a href="#">Section 6.3.2, "Configuration Select (CFG_SEL[1:0]),"</a> on page 28 for additional information.</p> <p>See <a href="#">Note 3.4</a> for more information on configuration straps.</p>

Table 3.1 Pin Descriptions (continued)

NUM PINS	NAME	SYMBOL	BUFFER TYPE	DESCRIPTION
1	Port 1 Power Output	P RTPWR1	O8	Enables power to a downstream USB device attached to Port 1.  0 = Power disabled on downstream Port 1 1 = Power enabled on downstream Port 1
	Port 1 Control	P RTCTL1	OD8/IS (PU)	When configured as P RTCTL1, this pin functions as both the Port 1 power enable output (P RTPWR1) and the Port 1 over-current sense input (OCS1_N). Refer to the P RTPWR1 and OCS1_N descriptions for additional information.
	Port 1 Battery Charging Configuration Strap	<u>BC_EN1</u>	IS	This strap is used to indicate support of the battery charging protocol on Port 1. Enabling battery charging support allows a device on the port to draw currents per the USB battery charging specification.  0 = Battery charging is not supported on Port 1 1 = Battery charging is supported on Port 1  See <a href="#">Note 3.4</a> for more information on configuration straps.
1	Port 2 Power Output	P RTPWR2	O8	Enables power to a downstream USB device attached to Port 2.  0 = Power disabled on downstream Port 2 1 = Power enabled on downstream Port 2
	Port 2 Control	P RTCTL2	OD8/IS (PU)	When configured as P RTCTL2, this pin functions as both the Port 2 power enable output (P RTPWR2) and the Port 2 over-current sense input (OCS2_N). Refer to the P RTPWR2 and OCS2_N descriptions for additional information.
	Port 2 Battery Charging Configuration Strap	<u>BC_EN2</u>	IS	This strap is used to indicate support of the battery charging protocol on Port 2. Enabling battery charging support allows a device on the port to draw currents per the USB battery charging specification.  0 = Battery charging is not supported on Port 2 1 = Battery charging is supported on Port 2  See <a href="#">Note 3.4</a> for more information on configuration straps.
8	No Connect	NC	-	These pins must be left floating for normal device operation.
<b>POWER</b>				
3	+3.3V Analog Power Supply	VDDA33	P	+3.3V analog power supply. Refer to <a href="#">Chapter 4, "Power Connections,"</a> on page 20 for power connection information.
2	+3.3V Power Supply	VDD33	P	+3.3V power supply. These pins must be connected to VDDA33. Refer to <a href="#">Chapter 4, "Power Connections,"</a> on page 20 for power connection information.



Table 3.1 Pin Descriptions (continued)

NUM PINS	NAME	SYMBOL	BUFFER TYPE	DESCRIPTION
1	+1.2V Core Power Supply	VDDCR12	P	+1.2V core power supply. A 1.0 $\mu$ F (<1 $\Omega$ ESR) capacitor to ground is required for regulator stability. The capacitor should be placed as close as possible to the device. Refer to <a href="#">Chapter 4, "Power Connections,"</a> on page 20 for power connection information.
Exposed Pad on package bottom (Figure 3.1)	Ground	VSS	P	Common ground. This exposed pad must be connected to the ground plane with a via array.

**Note 3.2** The LOCAL\_PWR pin is sampled during the configuration state, immediately after negation of reset, to determine whether the device is bus-powered or self-powered. When configuration is complete, the latched value will not change until the next reset assertion. To enable dynamic local power switching, the DYNAMIC\_POWER register at location 0x4134 must be programmed with 0x41. If dynamic power switching is not required, the DYNAMIC\_POWER register should be left at the default value of 0xC1. Programming may be performed through the SMBus interface, or permanently via OTP. Refer to the Protouch MPT User Manual for additional information.

**Note 3.3** If using the local power detect function (LOCAL\_PWR pin), the NON\_REM[1:0] configuration straps cannot be used to configure the non-removable state of the USB ports. In this case, the non-removable state of the ports must be configured in internal device registers via the Protouch tool or SMBus.

**Note 3.4** Configuration strap values are latched on Power-On Reset (POR) and the rising edge of RESET\_N (external chip reset). Configuration straps are identified by an underlined symbol name. Signals that function as configuration straps must be augmented with an external resistor when connected to a load. Refer to [Section 6.3, "Device Configuration Straps,"](#) on page 28 for additional information.

## 3.2 Pin Assignments

Table 3.2 36-SQFN Package Pin Assignments

PIN NUM	PIN NAME	PIN NUM	PIN NAME
1	SWAP_USBDN1_DM/PRT_DIS_M1	19	UART_RX/
2	SWAP_USBDN1_DP/PRT_DIS_P1	20	
3	USBDN2_DM/PRT_DIS_M2	21	UART_TX/
4	USBDN2_DP/PRT_DIS_P2	22	SDA/SMBDATA/NON_REM1
5	NC	23	VDD33
6	NC	24	SCL/SMBCLK/CFG_SEL0
7	NC	25	HS_IND/CFG_SEL1
8	NC	26	RESET_N
9	NC	27	VBUS_DET
10	VDDA33	28	SUSP_IND/LOCAL_PWR/NON_REM0
11	LED0	29	VDDA33
12	PRTPWR1/PRTCTL1/BC_EN1	30	FLEX_USBUP_DM
13	OCS1_N	31	FLEX_USBUP_DP
14	VDDCR12	32	XTAL2
15	VDD33	33	XTAL1/REFCLK
16	PRTPWR2/PRTCTL2/BC_EN2	34	NC
17	OCS2_N	35	RBIAS
18	NC	36	VDDA33

### 3.3 Buffer Type Descriptions

Table 3.3 Buffer Types

BUFFER TYPE	DESCRIPTION
IS	Schmitt-triggered input
I_RST	Reset Input
I_SMB	I <sup>2</sup> C/SMBus Clock Input
O8	Output with 8 mA sink and 8 mA source
OD8	Open-drain output with 8 mA sink
OD12	Open-drain output with 12 mA sink
PU	50 $\mu$ A (typical) internal pull-up. Unless otherwise noted in the pin description, internal pull-ups are always enabled. <b>Note:</b> Internal pull-up resistors prevent unconnected inputs from floating. Do not rely on internal resistors to drive signals external to the device. When connected to a load that must be pulled high, an external resistor must be added.
PD	50 $\mu$ A (typical) internal pull-down. Unless otherwise noted in the pin description, internal pull-downs are always enabled. <b>Note:</b> Internal pull-down resistors prevent unconnected inputs from floating. Do not rely on internal resistors to drive signals external to the device. When connected to a load that must be pulled low, an external resistor must be added.
AIO	Analog bi-directional
ICLK	Crystal oscillator input pin
OCLK	Crystal oscillator output pin
P	Power pin

## Chapter 4 Power Connections

### 4.1 Integrated Power Regulators

The integrated 3.3V and 1.2V power regulators allow the device to be supplied via a single 3.3V external power supply.

The regulators are controlled by RESET\_N. When RESET\_N is brought high, the 3.3V regulator will turn on. When RESET\_N is brought low the 3.3V regulator will turn off.

### 4.2 Power Connection Diagrams

Figure 4.1 illustrates the power connections for the USB2532.

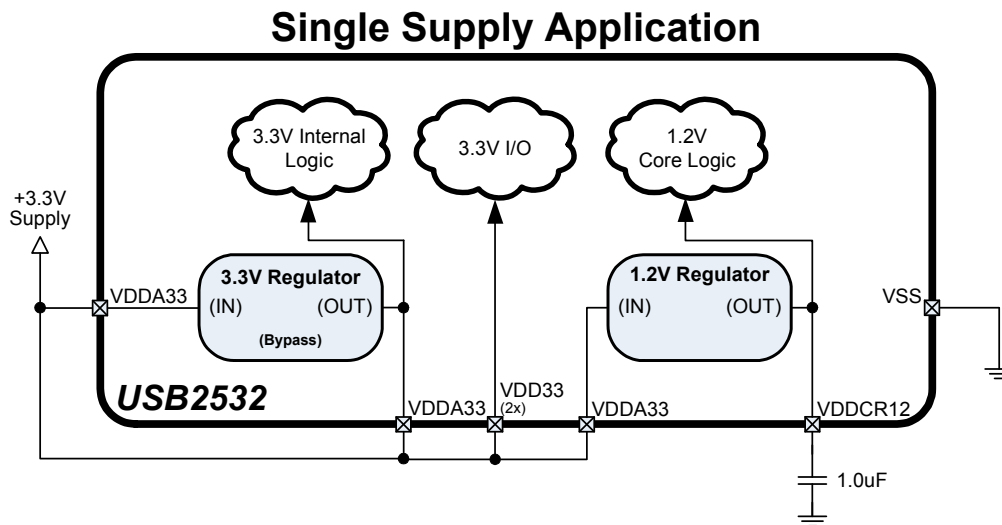

Figure 4.1 Power Connections

## Chapter 5 Modes of Operation

The device provides two main modes of operation: Standby Mode and Hub Mode. The operating mode of the device is selected by setting values on primary inputs according to the table below.

**Table 5.1 Controlling Modes of Operation**

RESET_N INPUT	RESULTING MODE	SUMMARY
0	<b>Standby</b>	<b>Lowest Power Mode:</b> No functions are active other than monitoring the RESET_N input. All port interfaces are high impedance. All regulators are powered off.
1	<b>Hub</b>	<b>Full Feature Mode:</b> Device operates as a configurable USB hub with battery charger detection. Power consumption is based on the number of active ports, their speed, and amount of data transferred.

**Note:** Refer to [Section 8.3.2, "External Chip Reset \(RESET\\_N\),"](#) on page 47 for additional information on RESET\_N.

The flowchart in [Figure 5.1](#) shows the modes of operation. It also shows how the device traverses through the Hub mode stages (shown in bold.) The flow of control is dictated by control register bits shown in italics as well as other events such as availability of a reference clock. The remaining sections in this chapter provide more detail on each stage and mode of operation.

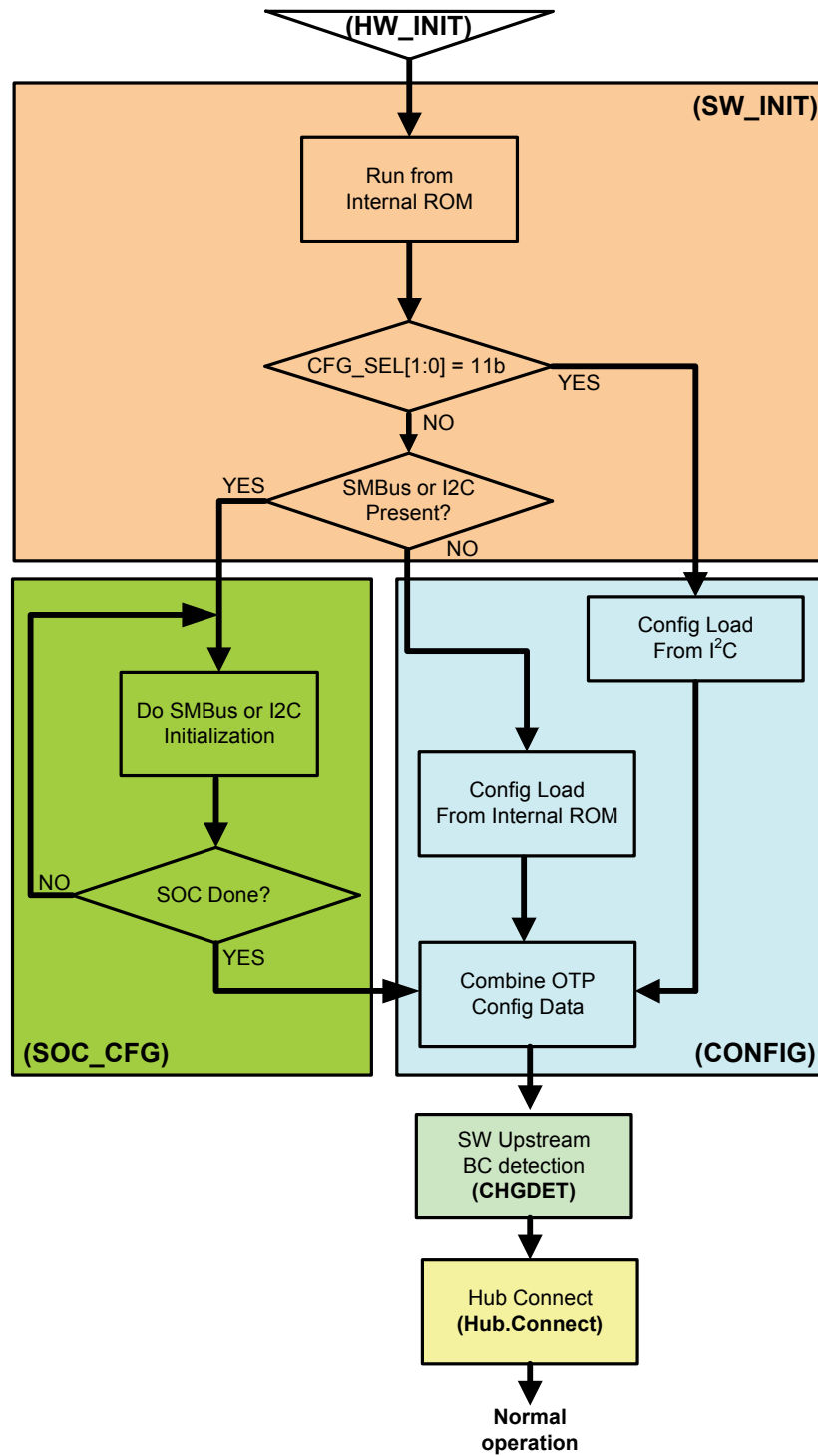

Figure 5.1 Hub Operational Mode Flowchart

## 5.1 Boot Sequence

### 5.1.1 Standby Mode

If the external hardware reset is asserted, the hub will be in Standby Mode. This mode provides a very low power state for maximum power efficiency when no signaling is required. This is the lowest power state. In Standby Mode all internal regulators are powered off, the PLL is not running, and core logic is powered down in order to minimize power consumption. Because core logic is powered off, no configuration settings are retained in this mode and must be re-initialized after RESET\_N is negated high.

### 5.1.2 Hardware Initialization Stage (HW\_INIT)

The first stage is the initialization stage and occurs on the negation of RESET\_N. In this stage the 1.2V regulator is enabled and stabilizes, internal logic is reset, and the PLL locks if a valid REFCLK is supplied. Configuration registers are initialized to their default state and strap input values are latched. The device will complete initialization and automatically enter the next stage. Because the digital logic within the device is not yet stable, no communication with the device using the SMBus is possible. Configuration registers are initialized to their default state.

If there is a REFCLK present, the next state is SW\_INIT.

### 5.1.3 Software Initialization Stage (SW\_INIT)

Once the hardware is initialized, the firmware can begin to execute from the internal ROM. The firmware checks the `CFG_SEL[1:0]` configuration strap values to determine if it is configured for I<sup>2</sup>C Master loading. If so, the configuration is loaded from an external I<sup>2</sup>C ROM in the device's CONFIG state.

For all other configurations, the firmware checks for the presence of an external I<sup>2</sup>C/SMBus. It does this by asserting two pull down resistors on the data and clock lines of the bus. The pull downs are typically 50Kohm. If there are 10Kohm pull-ups present, the device becomes aware of the presence of an external SMBus/I<sup>2</sup>C bus. If a bus is detected, the firmware transitions to the SOC\_CFG state.

### 5.1.4 SOC Configuration Stage (SOC\_CFG)

In this stage, the SOC may modify any of the default configuration settings specified in the integrated ROM such as USB device descriptors, or port electrical settings, and control features such as upstream battery charging detection.

There is no time limit. In this stage the firmware will wait indefinitely for the SMBus/I<sup>2</sup>C configuration. When the SOC has completed configuring the device, it must write to register 0xFF to end the configuration.

### 5.1.5 Configuration Stage (CONFIG)

Once the SOC has indicated that it is done with configuration, then all the configuration data is combined. The default data, the SOC configuration data, the OTP data are all combined in the firmware and device is programmed.

After the device is fully configured, it will go idle and then into suspend if there is no VBUS or Hub.Connect present. Once VBUS is present, and upstream battery charging is enabled, the device will transition to the Battery Charger Detection Stage (CHGDET). If VBUS is present, and upstream battery charging is not enabled, the device will transition to the Connect (Hub.Connect) stage.

### 5.1.6 Battery Charger Detection Stage (CHGDET)

After configuration, if enabled, the device enters the Battery Charger Detection Stage. If the battery charger detection feature was disabled during the CONFIG stage, the device will immediately transition to the Hub Connect (Hub.Connect) stage. If the battery charger detection feature remains enabled, the battery charger detection sequence is started automatically.

If the charger detection remains enabled, the device will transition to the Hub.Connect stage if using the hardware detection mechanism.

### 5.1.7 Hub Connect Stage (Hub.Connect)

Once the CHGDET stage is completed, the device enters the Hub.Connect stage.

### 5.1.8 Normal Mode

Lastly the SOC enters the Normal Mode of operation. In this stage, full USB operation is supported under control of the USB Host on the upstream port. The device will remain in the normal mode until the operating mode is changed by the system. The only device registers accessible to the SOC are the run time registers described in [Section 7.2.1, "SMBus Run Time Accessible Registers," on page 31](#).

If RESET\_N is asserted low, then Standby Mode is entered. The device may then be placed into any of the designated Hub stages. Asserting the soft disconnect on the upstream port will cause the Hub to return to the Hub.Connect stage until the soft disconnect is negated.

To save power, communication over the SMBus is not supported while in USB Suspend. The system can prevent the device from going to sleep by asserting the ClkSusp control bit of the [Configure Portable Hub Register](#) anytime before entering USB Suspend. While the device is kept awake during USB Suspend, it will provide the SMBus functionality at the expense of not meeting USB requirements for average suspend current consumption.



## Chapter 6 Device Configuration

The device supports a large number of features (some mutually exclusive), and must be configured in order to correctly function when attached to a USB host controller. The hub can be configured either internally or externally depending on the implemented interface.

SMSC provides a comprehensive software programming tool, Pro-Touch, for configuring the USB2532 functions, registers and OTP memory. All configuration is to be performed via the Pro-Touch programming tool. For additional information on the Pro-Touch programming tool, contact your local SMSC sales representative.

### 6.1 Configuration Method Selection

The CFG\_SEL[1:0] configuration straps and the SDA pin are used to determine the hub configuration method, as shown in [Table 6.1](#). The software reads the SDA pin and the CFG\_SEL[1:0] bits and configures the system appropriately.

**Table 6.1 Hub Configuration Selection**

SDA	CFG_SEL1	CFG_SEL0	DESCRIPTION
X	0	0	Configuration is based on the configuration strap options and internal OTP settings. This configuration sets the device Self powered operation.
0	0	1	Invalid
X	1	0	Configuration based on the configuration strap options and internal OTP settings. This configuration sets the device for Bus powered operation.
0	1	1	Firmware performs a configuration load from 2-wire (I <sup>2</sup> C) EEPROM. The device does not perform an SMBus Master detection. Configuration is controlled by EEPROM values and OTP settings. Strap options are disabled.
1	X	1	Firmware must wait for configuration from an SMBus Master. Configuration is controlled by SMBus Master and OTP settings. Strap options are disabled.

**Note:** Refer to [Chapter 7, "Device Interfaces," on page 30](#) for detailed information on each device configuration interface.

### 6.2 Customer Accessible Functions

The following USB or SMBus accessible functions are available to the customer via the SMSC Pro-Touch Programming Tool.

**Note:** For additional programming details, refer to the SMSC Pro-Touch Programming Tool User Manual.

## 6.2.1 USB Accessible Functions

### 6.2.1.1 VSM commands over USB

By default, Vendor Specific Messaging (VSM) commands to the hub are enabled. The supported commands are:

- Enable Embedded Controller
- Disable Embedded Controller
- Enable Special Resume
- Disable Special Resume
- Reset Hub

### 6.2.1.2 I<sup>2</sup>C Master Access over USB

Access to I<sup>2</sup>C devices is performed as a pass-through operation from the USB Host. The device firmware has no knowledge of the operation of the attached I<sup>2</sup>C device. The supported commands are:

- Enable I<sup>2</sup>C pass through mode
- Disable I<sup>2</sup>C pass through mode
- I<sup>2</sup>C write
- I<sup>2</sup>C read
- Send I<sup>2</sup>C start
- Send I<sup>2</sup>C stop

### 6.2.1.3 OTP Access over USB

The OTP ROM in the device is accessible via the USB bus. All OTP parameters can be modified via the USB Host. The OTP operates in Single Ended mode. The supported commands are:

- Enable OTP reset
- Set OTP operating mode
- Set OTP read mode
- Program OTP
- Get OTP status
- Program OTP control parameters

### 6.2.1.4 Battery Charging Access over USB

The Battery charging behavior of the device can be dynamically changed by the USB Host when something other than the preprogrammed or OTP programmed behavior is desired. The supported commands are:

- Enable/Disable battery charging
- Upstream battery charging mode control
- Downstream battery charging mode control
- Battery charging timing parameters
- Download custom battery charging algorithm

### 6.2.1.5 Other Embedded Controller functions over USB

The following miscellaneous functions may be configured via USB:

- Enable/Disable Embedded controller enumeration
- Program Configuration parameters.
- Program descriptor fields:
  - Language ID
  - Manufacturer string
  - Product string
  - idVendor
  - idProduct
  - bcdDevice

## 6.2.2 SMBus Accessible Functions

### 6.2.2.1 OTP Access over SMBus

The device's OTP ROM is accessible over SMBus. All OTP parameters can be modified via the SMBus Host. The OTP can be programmed to operate in Single-Ended, Differential, Redundant, or Differential Redundant mode, depending on the level of reliability required. The supported commands are:

- Enable OTP reset
- Set OTP operating mode
- Set OTP read mode
- Program OTP
- Get OTP Status
- Program OTP control parameters

### 6.2.2.2 Configuration Access over SMBus

The following functions are available over SMBus prior to the hub attaching to the USB host:

- Program Configuration parameters.
- Program descriptor fields:
  - Language ID
  - Manufacturer string
  - Product string
  - idVendor
  - idProduct
  - bcdDevice
- Program Control Register

### 6.2.2.3 Run time Access over SMBus

There is a limited number of registers that are accessible via the SMBus during run time operation of the device. Refer to [Section 7.2.1, "SMBus Run Time Accessible Registers," on page 31](#) for details.

## 6.3 Device Configuration Straps

Configuration straps are multi-function pins that are driven as outputs during normal operation. During a [Power-On Reset \(POR\)](#) or an [External Chip Reset \(RESET\\_N\)](#), these outputs are tri-stated. The high or low state of the signal is latched following de-assertion of the reset and is used to determine the default configuration of a particular feature. Configuration straps are latched as a result of a [Power-On Reset \(POR\)](#) or a [External Chip Reset \(RESET\\_N\)](#). Configuration strap signals are noted in [Chapter 3, "Pin Descriptions,"](#) on page 10 and are identified by an underlined symbol name. The following subsections detail the various configuration straps.

Configuration straps include internal resistors in order to prevent the signal from floating when unconnected. If a particular configuration strap is connected to a load, an external pull-up or pull-down should be used to augment the internal resistor to ensure that it reaches the required voltage level prior to latching. The internal resistor can also be overridden by the addition of an external resistor.

**Note:** The system designer must guarantee that configuration straps meet the timing requirements specified in [Section 9.5.2, "Reset and Configuration Strap Timing,"](#) on page 56 and [Section 9.5.1, "Power-On Configuration Strap Valid Timing,"](#) on page 55. If configuration straps are not at the correct voltage level prior to being latched, the device may capture incorrect strap values.

**Note:** Configuration straps must never be driven as inputs. If required, configuration straps can be augmented, or overridden with external resistors.

### 6.3.1 Non-Removable Device (NON\_REM[1:0])

The NON\_REM[1:0] configuration straps are sampled at RESET\_N negation to determine if ports [2:1] contain permanently attached (non-removable) devices as follows. Additionally, because the SUSP\_IND indicator functionality is shared with the NON\_REM0 configuration strap, the active state of the LED connected to SUSP\_IND will be determined as follows:

**Table 6.2 NON\_REM[1:0] Configuration Definitions**

<u>NON_REM[1:0]</u>	DEFINITION
'00'	All USB ports removable, SUSP_IND LED active high
'01'	Port 1 is non-removable, SUSP_IND LED active low
'10'	Ports 1 & 2 are non-removable, SUSP_IND LED active high
'11'	Ports 1 & 2 are non-removable, SUSP_IND LED active low

**Note:** If using the local power detect function (LOCAL\_PWR pin), the NON\_REM[1:0] configuration straps cannot be used to configure the non-removable state of the USB ports. In this case, the non-removable state of the ports must be configured in internal device registers via the Protouch tool or SMBus.

### 6.3.2 Configuration Select (CFG\_SEL[1:0])

Refer to [Section 6.1, "Configuration Method Selection,"](#) on page 25 for details on CFG\_SEL[1:0].

### 6.3.3 Downstream Battery Charging Enable (BC\_EN[2:1])

The battery charging enable configuration straps are used to enable battery charging on the corresponding downstream port. For example, if BC\_EN1 is driven high during the configuration strap

latching time, downstream port 1 will indicate support of battery charging. Refer to [Section 8.1.2, "Downstream Battery Charging,"](#) on page 45 for additional information on battery charging.

### 6.3.4 Port Disable (PRT\_DIS\_Mx/PRT\_DIS\_Px)

These configuration straps disable the associated USB ports D- and D+ signals, respectively, where "x" is the USB port number. Both the negative "M" and positive "P" port disable configuration straps for a given USB port must be tied high at reset to disable the associated port.

**Table 6.3 PRT\_DIS\_Mx/PRT\_DIS\_Px Configuration Definitions**

<u>PRT_DIS_Mx/PRT_DIS_Px</u>	DEFINITION
'0'	Port x D-/D+ Signal is Enabled (Default)
'1'	Port x D-/D+ Signal is Disabled

## Chapter 7 Device Interfaces

The USB2532 provides multiple interfaces for configuration and external memory access. This chapter details the various device interfaces and their usage.

**Note:** For information on device configuration, refer to [Chapter 6, "Device Configuration,"](#) on page 25.

### 7.1 I<sup>2</sup>C Master Interface

The I<sup>2</sup>C master interface implements a subset of the I<sup>2</sup>C Master Specification (Please refer to the *Philips Semiconductor Standard I<sup>2</sup>C-Bus Specification* for details on I<sup>2</sup>C bus protocols). The device's I<sup>2</sup>C master interface is designed to attach to a single "dedicated" I<sup>2</sup>C EEPROM for loading configuration data and conforms to the Standard-Mode I<sup>2</sup>C Specification (100 kbit/s transfer rate and 7-bit addressing) for protocol and electrical compatibility. The device acts as the master and generates the serial clock SCL, controls the bus access (determines which device acts as the transmitter and which device acts as the receiver), and generates the START and STOP conditions.

**Note:** Extensions to the I<sup>2</sup>C Specification are not supported.

**Note:** All device configuration must be performed via the SMSC Pro-Touch Programming Tool. For additional information on the Pro-Touch programming tool, contact your local SMSC sales representative.

#### 7.1.1 I<sup>2</sup>C Message Format

##### 7.1.1.1 Sequential Access Writes

The I<sup>2</sup>C interface supports sequential writing of the device's register address space. This mode is useful for configuring contiguous blocks of registers. [Figure 7.1](#) shows the format of the sequential write operation. Where color is visible in the figure, blue indicates signaling from the I<sup>2</sup>C master, and gray indicates signaling from the slave.

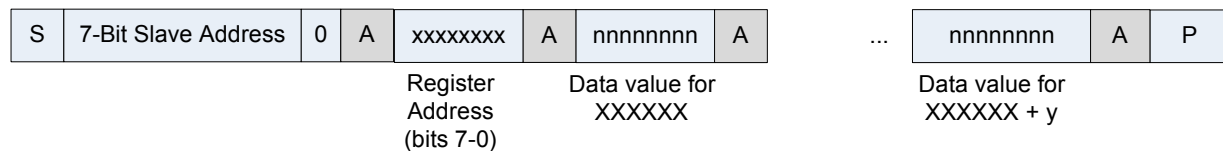

**Figure 7.1 I<sup>2</sup>C Sequential Access Write Format**

In this operation, following the 7-bit slave address, the 8-bit register address is written indicating the start address for sequential write operation. Every subsequent access is a data write to a data register, where the register address increments after each access and an ACK from the slave occurs. Sequential write access is terminated by a Stop condition.

##### 7.1.1.2 Sequential Access Reads

The I<sup>2</sup>C interface supports direct reading of the device registers. In order to read one or more register addresses, the starting address must be set by using a write sequence followed by a read. The read register interface supports auto-increment mode. The master must send a NACK instead of an ACK when the last byte has been transferred.

In this operation, following the 7-bit slave address, the 8-bit register address is written indicating the start address for the subsequent sequential read operation. In the read sequence, every data access is a data read from a data register where the register address increments after each access. The write sequence can end with optional Stop (P). If so, the read sequence must begin with a Start (S). Otherwise, the read sequence must start with a Repeated Start (Sr).

Figure 7.2 shows the format of the read operation. Where color is visible in the figure, blue and gold indicate signaling from the I<sup>2</sup>C master, and gray indicates signaling from the slave.

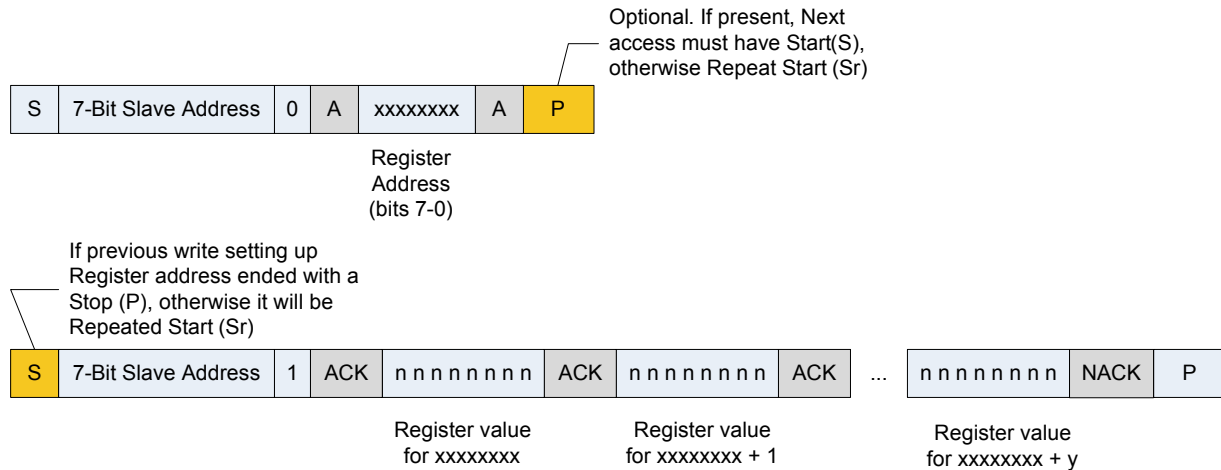

Figure 7.2 I<sup>2</sup>C Sequential Access Read Format

### 7.1.2 Pull-Up Resistors for I<sup>2</sup>C

The circuit board designer is required to place external pull-up resistors (10 kΩ recommended) on the SDA & SCL signals (per SMBus 1.0 Specification) to Vcc in order to assure proper operation.

## 7.2 SMBus Slave Interface

The USB2532 includes an integrated SMBus slave interface, which can be used to access internal device run time registers or program the internal OTP memory. SMBus detection is accomplished by detection of pull-up resistors (10 kΩ recommended) on both the SMBDATA and SMBCLK signals. To disable the SMBus, a pull-down resistor of 10 kΩ must be applied to SMBDATA. The SMBus interface can be used to configure the device as detailed in Section 6.1, "Configuration Method Selection," on page 25.

**Note:** All device configuration must be performed via the SMSC Pro-Touch Programming Tool. For additional information on the Pro-Touch programming tool, contact your local SMSC sales representative.

### 7.2.1 SMBus Run Time Accessible Registers

Table 7.1 provides a summary of the SMBus accessible run time registers. Each register is detailed in the subsequent tables.

**Note:** The SMBus page register must be configured to allow the SOC to access the proper register space. Refer to [Section 7.2.2, "Run Time SMBus Page Register,"](#) on page 43 for details.

**Table 7.1 SMBus Accessible Run Time Registers**

NAME	XDATA ADDR	
UP_BC_DET	0x30E2	<a href="#">Table 7.2, "Upstream Battery Charging Detection Control Register"</a>
UP_CUST_BC_CTL	0x30E3	<a href="#">Table 7.3, "Upstream Custom Battery Charger Control Register"</a>
UP_CUST_BC_STAT	0x30E4	<a href="#">Table 7.4, "Upstream Custom Battery Charger Status Register"</a>
PORT_PWR_STAT	0x30E5	<a href="#">Table 7.5, "Port Power Status Register"</a>
OCS_STAT	0x30E6	<a href="#">Table 7.6, "OCS Status Register"</a>
BC_CHG_MODE	0x30EC	<a href="#">Table 7.7, "Upstream Battery Charger Mode Register"</a>
CHG_DET_MSK	0x30ED	<a href="#">Table 7.8, "Charge Detect Mask Register"</a>
CFGP	0x30EE	<a href="#">Table 7.9, "Configure Portable Hub Register"</a>
PSELSUSP	0x318B	<a href="#">Table 7.10, "Port Select and Low-Power Suspend Register"</a>
CONNECT_CFG	0x318E	<a href="#">Table 7.11, "Connect Configuration Register"</a>
BC_CTL_1 (Upstream)	0x6100	<a href="#">Table 7.12, "Upstream (Port 0) Battery Charging Control 1 Register"</a>
BC_CTL_2 (Upstream)	0x6101	<a href="#">Table 7.13, "Upstream (Port 0) Battery Charging Control 2 Register"</a>
BC_CTL_RUN_TIME (Upstream)	0x6102	<a href="#">Table 7.14, "Upstream (Port 0) Battery Charging Run Time Control Register"</a>
BC_CTL_DET (Upstream)	0x6103	<a href="#">Table 7.15, "Upstream (Port 0) Battery Charging Detect Register"</a>



Table 7.2 Upstream Battery Charging Detection Control Register

UP_BC_DET (0x30E2 - RESET= 0x02)			UPSTREAM BATTERY CHARGING REGISTER
BIT	NAME	R/W	DESCRIPTION
7:5	CHARGER_TYPE	R/W	<p>Read Only. This field indicates the result of the automatic charger detection. Values reported depend on EnhancedChrgDet bit setting in <a href="#">Upstream Battery Charger Mode Register</a>.</p> <p>If EnhancedChrgDet = 1            000 = Charger Detection is not complete.            001 = DCP - Dedicated Charger Port            010 = CDP – Charging Downstream Port            011 = SDP – Standard Downstream Port            100 = Apple Low Current Charger            101 = Apple High Current Charger            110 = Apple Super High Current Charger            111 = Charger Detection Disabled</p> <p>If EnhancedChrgDet = 0            000 = Charger Detection is not complete.            001 = DCP/CDP – Dedicated Charger or Charging Downstream Port            010 = Reserved            011 = SDP – Standard Downstream Port            100 = Apple Low Current Charger            101 = Apple High Current Charger            110 = Apple Super High Current Charger            111 = Charger Detection Disabled</p>
4	CHGDET_COMPLETE	R	Indicates Charger Detection has been run and is completed. This bit is negated when START_CHG_DET is asserted high.
3	Reserved	R/W	Reserved for debugging
2:1	CHG_DET[1:0]	R	<p>Indicates encoded status of what chargers or status has been detected according to the settings in the <a href="#">Charge Detect Mask Register</a>. It can be used to determine what current can be drawn from the upstream USB port.</p> <p>00 = No selected Chargers or Status identified            01 = 100ma (VBUS detect without enumeration)            10 = 500ma (Device enumerated, Set Config seen)            11 = 1000+ma (Charger detected)</p> <p>The actual current amount for the charger will be system dependent</p>
0	START_CHG_DET	R/W	<p>Manually Initiates a USB battery charger detection sequence at the time of assertion. This bit must not be set while hub is in operation. This bit is cleared automatically when the manual battery charger detection sequence is completed.</p> <p>0 = Write: No Effect / Read: Battery Charger Detection Sequence Completed or not run.            1 = Write: Start Battery Charger Detection / Read: Battery Charger Detection Sequence is running</p>

Table 7.3 Upstream Custom Battery Charger Control Register

UP_CUST_BC_CTL (0x30E3 - RESET= 0x00)			UPSTREAM CUSTOM BATTERY CHARGING CONTROL
BIT	NAME	R/W	DESCRIPTION
7	I2CControl	R/W	I <sup>2</sup> C control 0: I <sup>2</sup> C control disabled 1: I <sup>2</sup> C control enabled
6	DmPulldownEn	R/W	DM 15K pull down resistor control 0: DM 15K pull down resistor disabled 1: DM 15K pull down resistor enabled
5	DpPulldownEn	R/W	DP 15K pull down resistor control 0: DP 15K pull down resistor disabled 1: DP 15K pull down resistor enabled
4	IdatSinkEn	R/W	Idat current sink control 0: Idat current sink disabled 1: Idat current sink enabled
3	HostChrgEn	R/W	Host charger detection swap control 0: Charger detection connections of DP and DM are not swapped (standard) 1: Charger detection connections of DP and DM are swapped. The USB signal path is not reversed.
2	VdatSrcEn	R/W	Vdat voltage source control 0: Vdat voltage source disabled 1: Vdat voltage source enabled
1	ContactDetectEn	R/W	Contact detect current source control 0: Contact detect current source disabled 1: Contact detect current source enabled
0	SeRxEn	R/W	Single-ended receiver control 0: Single-ended receiver disabled 1: Single-ended receiver enabled

Table 7.4 Upstream Custom Battery Charger Status Register

UP_CUST_BC_STAT (0x30E4 - RESET= 0x00)			UPSTREAM CUSTOM BATTERY CHARGING STATUS
BIT	NAME	R/W	DESCRIPTION
7:4	Reserved	R	Reserved
3	RxHiCurr	R	DM high current Apple charger output 0: DM signal is not above the VSE_RXH threshold 1: DM signal is above the VSE_RXH threshold
2	DmSeRx	R	DM Single Ended Receiver Status
1	DpSeRx	R	DP Single Ended Receiver Status
0	VdatDet	R	Vdat detect 0: Vdat not detected 1: Vdat detect comparator output

Table 7.5 Port Power Status Register

PORT_PWR_STAT (0x30E5 - RESET= 0x00)			PORT POWER STATUS
BIT	NAME	R/W	DESCRIPTION
7:5	Reserved	R	Reserved
4:1	PRTPOWER[4:1]	R	Optional status to SOC indicating that power to the corresponding downstream port was enabled by the USB Host for the specified port. Not required for an embedded application.  This is a read-only status bit. Actual control over port power is implemented by the USB Host, <a href="#">OCS Status Register</a> and Downstream Battery Charging logic, if enabled.  0: USB Host has not enabled port to be powered or in downstream battery charging and corresponding OCS bit has been set 1: USB Host has enabled port to be powered
0	Reserved	R	Reserved

Table 7.6 OCS Status Register

OCS_STAT (0x30E6 - RESET= 0x00)			PORT POWER STATUS
BIT	NAME	R/W	DESCRIPTION
7:5	Reserved	R	Reserved
4:1	OCS[4:1]	R	Optional control from SOC that indicates an over-current condition on the corresponding port for HUB status reporting to USB host. Also resets corresponding PRTPWR status bit in the <a href="#">Port Power Status Register</a> . Not required for an embedded application.  0: No Over Current Condition 1: Over Current Condition
0	Reserved	R	Reserved

Table 7.7 Upstream Battery Charger Mode Register

BC_CHG_MODE (0x30EC - RESET= 0x00)			UPSTREAM BATTERY CHARGER MODE
BIT	NAME	R/W	DESCRIPTION
7:6	Reserved	R	Reserved
5	HoldVdat	R/W	Dead Battery Vdat Detect voltage source enable  0: The charger detection state machine will turn off the Vdat Source at the end of the charger detection routine. 1: The charger detection state machine leave Vdat Source on during Hub.Connect stage when a SDP has been detected.
4	Reserved	R	Reserved
3	SE1ChrgDet	R/W	Apple type charger detection control  0: The charger detection routine will not look for the attachment of an Apple type charger. 1: The charger detection routine will look for the attachment of an Apple type charger.
2	EnhancedChrgDet	R/W	Enhanced charge detect control  0: The charger detection routine will not reverse Vdat SRC to differentiate between a CDP and a DCP. 1: The charger detection routine will reverse Vdat SRC to differentiate between a CDP and a DCP.
1:0	Reserved	R	Reserved

Table 7.8 Charge Detect Mask Register

CHG_DET_MSK (0x30ED - RESET= 0x1F)			CHARGE DETECT MASK
BIT	NAME	R/W	DESCRIPTION
7	CONFIGURED	R/W	0: <i>battChg.chgDet</i> is not affected for this mask set when Hub is in a session and has been configured by the USB Host 1: <i>battChg.chgDet</i> indicates status for this mask set met when Hub is in a session and has been configured by the USB Host
6	CONNECTED	R/W	0: <i>battChg.chgDet</i> is not affected for this mask set when Hub has successfully connected with an upstream Host 1: <i>battChg.chgDet</i> indicates status for this mask set met when Hub has successfully connected with an upstream host.
5	SUSPENDED	R/W	0: <i>battChg.chgDet</i> is not affected for this mask set when Hub is in a session and has been suspended by the USB Host 1: <i>battChg.chgDet</i> indicates status for this mask set met when Hub is in a session and has been suspended by the USB Host
4	SE1SMask	R/W	0: <i>battChg.chgDet</i> is not affected for this mask set by detection of a Apple Super High Current Charger 1: <i>battChg.chgDet</i> indicates status for this mask set met when a SE1 (Apple) Super High Current Charger is detected
3	SE1HMask	R/W	0: <i>battChg.chgDet</i> is not affected for this mask set by detection of a Apple High Current Charger 1: <i>battChg.chgDet</i> indicates status for this mask set met when a Apple High Current Charger is detected
2	SE1LMask	R/W	0: <i>battChg.chgDet</i> is not affected for this mask set by detection of a Apple Low Current Charger 1: <i>battChg.chgDet</i> indicates status for this mask set met when a Apple Low Current Charger is detected
1	CDPMask	R/W	0: <i>battChg.chgDet</i> is not affected for this mask set by detection of a CDP Charger 1: <i>battChg.chgDet</i> indicates status for this mask set met when a CDP Charger is detected  This mask bit should only be enabled if EnhancedChrgDet is asserted in the <a href="#">Upstream Battery Charger Mode Register</a> . Without it, the charger detection is unable to identify a CDP.
0	DCPMask	R/W	0: <i>battChg.chgDet</i> is not affected for this mask set by detection of a DCP Charger 1: <i>battChg.chgDet</i> indicates status for this mask set met when a DCP Charger is detected

**Table 7.9 Configure Portable Hub Register**

CFGP (0x30EE - RESET= 0x10)			PORTABLE HUB CONFIGURATION REGISTER
BIT	NAME	R/W	DESCRIPTION
7	ClkSusp	R/W	0: Allow device to gate-off its internal clocks during suspend mode in order to meet USB suspend current requirements.  1: Force device to run internal clock even during USB suspend (will cause device to violate USB suspend current limit - intended for test or self-powered applications which require use of SMBus during USB session.)
6	Reserved	R	Always read '0'
5:1	DIS_CHP_PHY_CLK[5:1]	R/W	A '1' disables the PHY clock of the corresponding port: Bit 5 - Downstream port 5 Bit 4 - Downstream port 4 Bit 3 - Downstream port 3 Bit 2 - Downstream port 2 Bit 1 - Downstream port 1
0	Reserved	R	Always read '0'

**Table 7.10 Port Select and Low-Power Suspend Register**

PSELSUSP (0x318B- RESET=0x00)			PORT SELECT AND LOW POWER SUSPEND REGISTER
BIT	NAME	R/W	DESCRIPTION
7:6	APortSel	R/W	Specifies which downstream USB port is associated with the PRTPWRA pin function.  '00' - Port 1 '01' - Port 2 '10' - Port 3 '11' - Port 4
5:0	Reserved	R	Always read '0'

**Note:** This register should be assigned during the Hub.Config or Hub.Connect stages, and should not be dynamically updated during Hub.Communication stage or undefined behavior may result.

Table 7.11 Connect Configuration Register

CONNECT_CFG (0x318E- RESET=0x00)			CONNECT CONFIGURATION REGISTER
BIT	NAME	R/W	DESCRIPTION
7:2	Reserved	R	Reserved
1	EN_FLEX_MODE	R/W	Flex Connect mode enable  0: Flex Connect mode is disabled. (Normal hub operation with separate port power and OCS control) 1: Flex Connect mode is enabled
0	FLEXCONNECT	R/W	<p>FlexConnect Control. When asserted the device changes its hub connections so that the Swap port (Physical Port 1) changes from it's default behavior of a downstream port to an upstream port. The Flex Port (Physical port 0) transitions from an upstream port to a downstream port.</p> <p>'0' - Flex Port = Upstream (Port 0) Swap Port= Downstream (Port 1)</p> <p>'1' - Flex Port= Downstream (Port 1) Swap Port= Upstream (Port 0)</p> <p>This setting can be used to select whether the Flex Port is an upstream or downstream port.</p> <p>Another application for this setting is to allow a dual-role device on the Swap Port to assume a host role and communicate directly with other downstream hub ports, or to communicate through the Flex Port to a exposed connector to an external device.</p> <p>If a "private" communication channel is desired between embedded devices, any externally exposed ports should be disabled.</p> <p>Note: All port-specific settings such as VSNS, prtSp, sDiscon are specific to the logic port 0, 1, 2, 3. When FLEXCONNECT is asserted, these settings affect the newly assigned physical pins and PHY. Any settings which are specific to the physical Flex Port and Swap Port such as battery charger detection do not change with the setting of FLEXCONNECT.</p>

Table 7.12 Upstream (Port 0) Battery Charging Control 1 Register

BC_CTL_1 (0x6100- RESET=0x00)			UPSTREAM (PORT 0) BATTERY CHARGING CONTROL 1 REGISTER
BIT	NAME	R/W	DESCRIPTION
7	USB2_IDP_SRC_EN	R/W	AFE 10uA I <sub>DP_SRC</sub> current source Enable 0: Disabled (Hi Z) 1: Enabled
6	USB2_VDAT_SRC_EN	R/W	AFE 0.6V V <sub>DATA_SRC</sub> voltage source Enable 0: Disabled (Hi Z) 1: Enabled
5	USB2_HOST_CHRG_EN	R/W	Enable charging host port mode 0: Portable Device 1: Charging Host port.  When the charging host port is bit is set, the connections of V <sub>DATA_SRC</sub> , I <sub>DAT_SINK</sub> , I <sub>DP_SRC</sub> , V <sub>DAT_DET</sub> are reversed between DP and DM
4	USB2_IDAT_SINK_EN	R/W	AFE 100uA current sink and the V <sub>DAT_DET</sub> comparator Enable 0: Disabled (Hi Z) 1: Enabled
3	USB2_VDAT_DET	R	V <sub>DAT_DET</sub> comparator output 0: No voltage detected 1: Voltage detected (a possible charger or a device)
2	USB2_BC_DP_RDIV_EN	R/W	AFE Battery Charging Resistor Divider Enable – DP. 0: Disables resistor divider on DP. 1: Enables 2.7V voltage reference on DP through use of 9.7K/48.5K resistor divider.
1	USB2_BC_DM_RDIV_EN	R/W	AFE Battery Charging Resistor Divider Enable – DM. 0: Disables resistor divider on DM. 1: Enables 2.0V voltage reference on DM through use of 29.1K/48.5K resistor divider.
0	USB2_DP_DM_SHORT_EN	R/W	Sets the port into China battery charger mode.



**Table 7.13 Upstream (Port 0) Battery Charging Control 2 Register**

<b>BC_CTL_2 (0x6101- RESET=0x00)</b>			<b>UPSTREAM (PORT 0) BATTERY CHARGING CONTROL 2 REGISTER</b>
<b>BIT</b>	<b>NAME</b>	<b>R/W</b>	<b>DESCRIPTION</b>
7	BC_10_125K_PU_DP	R/W	Setting this bit enables a 125K pull-up to VDD33 on DP. This is used for USB battery charging in 1.0 mode detection only.
6	BC_10_125K_PU_DM	R/W	Setting this bit enables a 125K pull-up to VDD33 on DM. This is used for USB battery charging in 1.0 mode detection only.
5	LINESTATE_DP	R	This is the direct value of the Full-Speed USB line state Data Plus. It is used for battery charging detection. This line is not valid in HS mode and should only be used in battery charging detection.
4	LINESTATE_DM	R	This is the direct value of the Full-Speed USB line state Data Minus. It is used for battery charging detection. This line is not valid in HS mode and should only be used for battery charging detection.
3	USB2_FS_DP	R	This is the raw Full-Speed single ended receiver output for Data Plus
2	USB2_FS_DM	R	This is the raw Full-Speed single ended receiver output for Data Minus
1:0	Reserved	R	Always read '0'

Table 7.14 Upstream (Port 0) Battery Charging Run Time Control Register

BC_CTL_RUN_TIME (0x6102- RESET=0x00)			UPSTREAM (PORT 0) BATTERY CHARGING RUN TIME CONTROL REGISTER
BIT	NAME	R/W	DESCRIPTION
7	Reserved	R	Always read '0
6	SUSPENDN	R/W	Suspend enable. Forces upstream port into suspend 0: Suspend disabled 1: Suspend enabled
5	RESET	R/W	Reset enable. Forces upstream port into reset 0: Reset disabled 1: Reset enabled
4	USB2_FS_OEB	R/W	Output Enable (OE). Forces upstream port into output enable 0: OE disabled 1: OE enabled
3	RPD_DP_EN	R/W	Data plus resistor pull-down enable 0: Data plus pull-down disabled 1: Data plus pull-down enabled
2	RPD_DM_EN	R/W	Data minus resistor pull-down enable 0: Data minus pull-down disabled 1: Data minus pull-down enabled
1:0	XCVRSELECT	R/W	Transceiver Select. This field selects between the LS, FS and HS transceivers. 2'b00: HS mode 2'b01: FS mode 2'b10: LS mode 2'b11: LS data-rate with FS rise/fall times (and EOP/IDLE) <b>Note:</b> Note: XCVRSELECT must change state only when the device is not actively transmitting or receiving

Table 7.15 Upstream (Port 0) Battery Charging Detect Register

BC_CTL_DET (0x6103- RESET=0x00)			UPSTREAM (PORT 0) BATTERY CHARGING DETECT REGISTER
BIT	NAME	R/W	DESCRIPTION
7:3	Reserved	R	Always read '0
2	USB2_BC_RXHI_EN	R/W	Enable pin for the Apple high current battery charger detection.
1	USB2_BC_RXHI_DET	R	Output pin for the Apple high current battery charger detection. When disabled this output will be low.
0	USB2_BC_BIAS_EN	R/W	When enabling <a href="#">USB2_IDAT_SINK_EN</a> or <a href="#">USB2_VDAT_SRC_EN</a> of the <a href="#">Upstream (Port 0) Battery Charging Control 1 Register</a> , this register bit must be set to enable the required current source.

## 7.2.2 Run Time SMBus Page Register

The following run time SMBus page register is located at 0xFF and must be programmed to allow the SOC to page through different pages of the register space.

**Table 7.16 SMBus Page Register**

SMBUS_PAGE (0xFF(I2C) - RESET= 0x00)			SMBUS PAGE REGISTER
BIT	NAME	R/W	DESCRIPTION
7:5	PAGE_SEL	R/W	From the I <sup>2</sup> C side, this field allows the I <sup>2</sup> C to select the accessible address space: 000 = Select registers in the 3000 space (0x30e2 - 0x30ee) 010 = Select registers in the 3100 space (0x318b,0x318e) 110 = Select register in the 6100 space (0x6100,0x6101,0x6102)
5:0	Reserved	R	Reserved. <b>Note:</b> Software must never write a '1' to these bits

## Chapter 8 Functional Descriptions

This chapter provides additional functional descriptions of key device features.

### 8.1 Battery Charger Detection & Charging

The USB2532 supports both upstream battery charger detection and downstream battery charging. The integrated battery charger detection circuitry supports the USB-IF Battery Charging (BC1.2) detection method and most Apple devices. These circuits are used to detect the attachment and type of a USB charger and provide an interrupt output to indicate charger information is available to be read from the device's status registers via the serial interface. The USB2532 provides the battery charging handshake and supports the following USB-IF BC1.2 charging profiles:

- DCP: Dedicated Charging Port (Power brick with no data)
- CDP: Charging Downstream Port (1.5A with data)
- SDP: Standard Downstream Port (0.5A with data)
- Custom profiles loaded via SMBus or OTP

The following sub-sections detail the upstream battery charger detection and downstream battery charging features.

#### 8.1.1 Upstream Battery Charger Detection

Battery charger detection is available on the upstream facing port. The detection sequence is intended to identify chargers which conform to the Chinese battery charger specification, chargers which conform to the USB-IF Battery Charger Specification 1.2, and most Apple devices.

In order to detect the charger, the device applies and monitors voltages on the upstream DP and DM pins. If a voltage within the specified range is detected, the will be updated to reflect the proper status.

The device includes the circuitry required to implement battery charging detection using the Battery Charging Specification. When enabled, the device will automatically perform charger detection upon entering the Hub.ChgDet stage in Hub Mode. The device includes a state machine to provide the detection of the USB chargers listed in the table below. The type of charger detected is returned in the CHARGER\_TYPE field of the .

**Table 8.1 Chargers Compatible with Upstream Detection**

USB ATTACH TYPE	DP/DM PROFILE	CHARGERTYPE
DCP (Dedicated Charging Port)	Shorted < 200ohm	001
CDP (Charging Downstream Port)	VDP reflected to VDM	010 (EnhancedChrgDet = 1)
SDP (Standard Downstream Port) USB Host or downstream hub port	15Kohm pull-down on DP and DM	011
Apple Low Current Charger	Apple	100
Apple High Current Charger	Apple	101
Apple Super High Current Charger	DP=2.7V DM=2.0V	110

**Table 8.1 Chargers Compatible with Upstream Detection (continued)**

USB ATTACH TYPE	DP/DM PROFILE	CHARGERTYPE
Apple Charger Low Current Charger (500mA)	DP=2.0V DM=2.0V	100
Apple Charger High Current Charger (1000mA)	DP=2.0V DM=2.7V	101

If a custom charger detection algorithm is desired, the SMBus registers can also be used to control the charger detection block to implement a custom charger detection algorithm. In order to avoid negative interactions with automatic battery charger detection or normal hub operation, the user should only attempt Custom battery charger detection during the Hub.Config stage or Hub.Connect stage. No logic is implemented to disable custom detection at other times - it is up to the user software to observe this restriction.

There is a possibility that the system is not running the reference clock when battery charger detection is required (for example if the battery is dead or missing). During the Hub.WaitRefClk stage the battery charger detection sequence can be configured to be followed regardless of the activity of REFCLK by relying on the operation of the internal oscillator.

## 8.1.2 Downstream Battery Charging

The device can be configured by an OEM to have any of the downstream ports to support battery charging. The Hub's role in battery charging is to provide an acknowledge to a device's query as to if the hub system supports USB battery charging. The hub silicon does not provide any current or power FETs or any additional circuitry to actually charge the device. Those components must be provided as externally by the OEM.

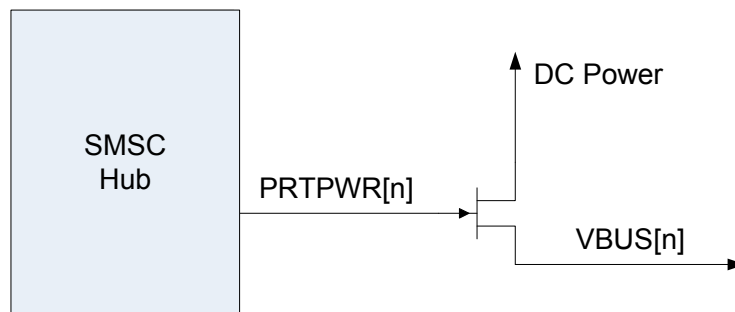
**Figure 8.1 Battery Charging External Power Supply**

If the OEM provides an external supply capable of supplying current per the battery charging specification, the hub can be configured to indicate the presence of such a supply to the device. This indication, via the PRT PWR[1:4] output pins, is on a per/port basis. For example, the OEM can configure two ports to support battery charging through high current power FET's and leave the other two ports as standard USB ports.

### 8.1.2.1 Downstream Battery Charging Modes

In the terminology of the USB Battery Charging Specification, if a port is configured to support battery charging, the downstream port is considered a CDP (Charging Downstream Port) if connected to a

USB host, or a DCP (Dedicated Charging Port) if not connected to a USB host. If the port is not configured to support battery charging, the port is considered an SDP (Standard Downstream Port). All charging ports have electrical characteristics different from standard non-charging ports.

A downstream port will behave as a CDP, DCP, or SDP depending on the port's configuration and mode of operation. The port will not switch between a CDP/DCP or SDP at any time after initial power-up and configuration. A downstream port can be in one of three modes shown in the table below.

**Table 8.2 Downstream Port Types**

USB ATTACH TYPE	DP/DM PROFILE
DCP (Dedicated Charging Port)	Apple charging mode or China Mode (Shorted < 200ohm) or SMSC custom mode
CDP (Charging Downstream Port)	VDP reflected to VDM
SDP (Standard Downstream Port) USB Host or downstream hub port	15Kohm pull-down on DP and DM

### 8.1.2.2 Downstream Battery Charging Configuration

Configuration of ports to support battery charging is performed via the BC\_EN configuration straps, USB configuration, SMBus configuration, or OTP. The Battery Charging Enable Register provides per port battery charging configuration. Starting from bit 1, this register enables battery charging for each downstream port when asserted. Bit 1 represents port 1 and so on. Each port with battery charging enabled asserts the corresponding PRTPWR register bit.

### 8.1.2.3 Downstream Over-Current Management

It is the devices responsibility to manage over-current conditions. Over-Current Sense (OCS) is handled according to the USB specification. For battery charging ports, PRTPWR is driven high (asserted) after hardware initialization. If an OCS event occurs, the PRTPWR is negated. PRTPWR will be negated for all ports in a ganged configuration. Only the respective PRTPWR will be negated in the individual configuration.

If there is an over-current event in DCP mode, the port is turned off for one second and is then re-enabled. If the OCS event persists, the cycle is repeated for a total of three times. If after three attempts, the OCS still persists, the cycle is still repeated, but with a retry interval of ten seconds. This retry persists for indefinitely. The indefinite retry prevents a defective device from permanently disabling the port.

In CDP or SDP mode, the port power and over-current events are controlled by the USB host. The OCS event does not have to be registered. When and if the hub is connected to a host, the host will initialize the hub and enable its port power. If the over current still exists, it will be notified at that point.

## 8.2 Flex Connect

This feature allows the upstream port to be swapped with downstream physical port 1. Only downstream port 1 can be swapped physically. Using port remapping, any logical port (number assignment) can be swapped with the upstream port (non-physical).

Flex Connect is enabled/disabled via two control bits in the [Connect Configuration Register](#). The FLEXCONNECT configuration bit switches the port, and EN\_FLEX\_MODE enables the mode.

### 8.2.1 Port Control

Once EN\_FLEX\_MODE bit is set, the functions of certain pins change, as outlined below.

If EN\_FLEX\_MODE is set and FLEXCONNECT is not set:

1. PRTPWR1 enters combined mode, becoming PRTPWR1/OCS1\_N
2. OCS1\_N becomes a don't care
3. SUSPEND outputs '0' to keep any upstream power controller off

If EN\_FLEX\_MODE is set and FLEXCONNECT is set:

1. The normal upstream VBUS pin becomes a don't care
2. PRTPWR1 is forced to a '1' in combined mode, keeping the port power on to the application processor.
3. OCS1 becomes VBUS from the application processor through a GPIO
4. SUSPEND becomes PRTPWR1/OCS1\_N for the port power controller for the connector port

## 8.3 Resets

The device has the following chip level reset sources:

- [Power-On Reset \(POR\)](#)
- [External Chip Reset \(RESET\\_N\)](#)
- [USB Bus Reset](#)

### 8.3.1 Power-On Reset (POR)

A power-on reset occurs whenever power is initially supplied to the device, or if power is removed and reapplied to the device. A timer within the device will assert the internal reset per the specifications listed in [Section 9.5.1, "Power-On Configuration Strap Valid Timing," on page 55](#).

### 8.3.2 External Chip Reset (RESET\_N)

A valid hardware reset is defined as assertion of RESET\_N, after all power supplies are within operating range, per the specifications in [Section 9.5.2, "Reset and Configuration Strap Timing," on page 56](#). While reset is asserted, the device (and its associated external circuitry) enters Standby Mode and consumes minimal current.

Assertion of RESET\_N causes the following:

1. The PHY is disabled and the differential pairs will be in a high-impedance state.
2. All transactions immediately terminate; no states are saved.
3. All internal registers return to the default state.

4. The external crystal oscillator is halted.
5. The PLL is halted.

**Note:** All power supplies must have reached the operating levels mandated in [Section 9.2, "Operating Conditions\\*\\*,"](#) on page 52, prior to (or coincident with) the assertion of RESET\_N.

### 8.3.3 USB Bus Reset

In response to the upstream port signaling a reset to the device, the device performs the following:

**Note:** The device does not propagate the upstream USB reset to downstream devices.

1. Sets default address to 0.
2. Sets configuration to: Unconfigured.
3. Moves device from suspended to active (if suspended).
4. Complies with Section 11.10 of the USB 2.0 Specification for behavior after completion of the reset sequence.

The host then configures the device in accordance with the USB Specification.

## 8.4 Link Power Management (LPM)

The device supports the L0 (On), L1 (Sleep), and L2 (Suspend) link power management states per the USB 2.0 Link Power Management Addendum. These supported LPM states offer low transitional latencies in the tens of microseconds versus the much longer latencies of the traditional USB suspend/resume in the tens of milliseconds. The supported LPM states are detailed in [Table 8.3](#). For additional information, refer to the USB 2.0 Link Power Management Addendum.

**Table 8.3 LPM State Definitions**

STATE	DESCRIPTION	ENTRY/EXIT TIME TO L0
L2	Suspend	Entry: ~3 ms Exit: ~2 ms
L1	Sleep	Entry: ~65 us Exit: ~100 us
L0	Fully Enabled (On)	-

**Note:** State change timing is approximate and is measured by change in power consumption.

**Note:** System clocks are stopped only in suspend mode or when power is removed from the device.

## 8.5 Remote Wakeup Indicator (SUSP\_IND)

The remote wakeup indicator feature uses the SUSP\_IND as a side band signal to wake up the host when in suspend. This feature is enabled and disabled via the HUB\_RESUME\_INHIBIT configuration bit in the hub configuration space register CFG3. The only way to control the bit is by configuration EEPROM, SMBus or internal ROM default setting. The state is only modified during a power on reset, or hardware reset. No dynamic reconfiguring of this capability is possible.



When HUB\_RESUME\_INHIBIT = '0', [Normal Resume Behavior](#) per the USB 2.0 specification

When HUB\_RESUME\_INHIBIT = '1', [Modified Resume Behavior](#) is enabled

Refer to the following subsections for additional details.

### 8.5.1 Normal Resume Behavior

VBUS\_DET is used to detect presence of the Host. If VBUS\_DET = '1', then D+ pull-up is asserted and normal USB functionality is enabled. The SUSP\_IND provides an indication of the active or suspended state of the hub.

The Hub will drive a 'K' on the upstream port if required to do so by USB protocol.

If VBUS\_DET = '0', then the D+ pull-up is negated. If battery charging is not enabled, the internal hub logic will be reset, thus negating all downstream ports and associated downstream VBUS enable signals. The hub will need to be re-enumerated to function, much like a new connect or after a complete system reset.

### 8.5.2 Modified Resume Behavior

When the modified resume feature is enabled, the hub functions as follows:

VBUS\_DET is used to detect presence of the Host. If VBUS\_DET = '1', then D+ pull-up is asserted and normal USB functionality is enabled. SUSP\_IND provides an indication of the active or suspended state of the hub.

The device will drive a 'K' on the upstream port and downstream ports if required to do so by USB protocol. The device will act as a controlling hub if required to do so by the USB protocol.

If VBUS\_DET = '0', then the D+ pull-up is negated, but the hub will not be internally reset. It will power-on the downstream ports. The hub is able to continue to detect downstream remote wake events.

SUSP\_IND provides an indication of the active or suspended state of the hub.

If a USB 2.0 specification compliant resume or wake event is detected by the device, the device is remote wake enabled, and a port status change event occurs, SUSP\_IND will be driven for the time given in the GLOBAL\_RESUME\_TIME register.

If a remote wake event is detected on a downstream port:

1. Device disconnect
2. Device connect
3. A currently connected device requests remote wake-up.

**Note:** Downstream resume events are filtered for approximately 100uS by internal logic.

The device will not drive a 'K' on the upstream port. Instead, the SUSP\_IND will be driven for approximately 14 ms. The 'K' is not driven upstream because this would potentially back drive a powered-down host. The device will drive RESUME to only the downstream ports which transmitted the remote wake signal per the requirements of the USB 2.0 specification for controlling hub behavior.

**Note:** SUSP\_IND is a one shot event. It will assert with each wake event detection. It will not repeatedly assert in proxy for downstream devices.

For the case where the Host responds and turns on VBUS and can drive a 'K' downstream within the 14 ms time frame of a standard resume (measured from the SUSP\_IND pin), then the hub detects the 'K'. It will discontinue "Controlling Hub" activities, drive resume signaling on any other ports, and

function as expected per the USB 2.0 Specification with respect to a resume event. It will permit the host to take over resume signaling.

For the case where the host is not able to drive a 'K' within the 14 ms time frame, the hub will stop sending a 'K' on the upstream and downstream ports. It must follow through as a controlling hub and properly terminate the resume with either an EOP or with HS terminations as is currently implemented in the selective resume case, per the USB specification.

## 8.6 High Speed Indicator (HS\_IND)

The HS\_IND pin can be used to drive an LED. The active state of the LED will be determined as follows:

- If CFG\_SEL1 = '0', HS\_IND is active high.
- If CFG\_SEL1 = '1', then HS\_IND is active low.

Assertion of HS\_IND indicates the device is connected at high speed. Negation of HS\_IND indicates the device is connected at full speed.

**Note:** This pin shares functionality with the CFG\_SEL1 configuration strap. The logic state of this pin is internally latched on the rising edge of RESET\_N (RESET\_N negation), and is used to determine the hub configuration method. Refer to [Section 6.3.2, "Configuration Select \(CFG\\_SEL\[1:0\]\)"](#), on page 28 for additional information.

## Chapter 9 Operational Characteristics

### 9.1 Absolute Maximum Ratings\*

+3.3 V Supply Voltage (VDD33, VDDA33) (Note 9.1) . . . . .	0 V to +3.6 V
Positive voltage on input signal pins, with respect to ground (Note 9.2) . . . . .	3.6 V
Negative voltage on input signal pins, with respect to ground . . . . .	-0.5 V
Positive voltage on XTAL1/REFCLK, with respect to ground . . . . .	VDDCR12
Positive voltage on USB DP/DM signals, with respect to ground (Note 9.3) . . . . .	5.5 V
Storage Temperature. . . . .	-55°C to +150°C
Lead Temperature Range . . . . .	Refer to JEDEC Spec. J-STD-020
HBM ESD Performance . . . . .	JEDEC Class 3A

**Note 9.1** When powering this device from laboratory or system power supplies, it is important that the absolute maximum ratings not be exceeded or device failure can result. Some power supplies exhibit voltage spikes on their outputs when AC power is switched on or off. In addition, voltage transients on the AC power line may appear on the DC output. If this possibility exists, it is suggested to use a clamp circuit.

**Note 9.2** This rating does not apply to the following signals: All USB DM/DP pins, XTAL1/REFCLK, XTAL2.

**Note 9.3** This rating applies only when VDD33 is powered.

\*Stresses exceeding those listed in this section could cause permanent damage to the device. This is a stress rating only. Exposure to absolute maximum rating conditions for extended periods may affect device reliability. Functional operation of the device at any condition exceeding those indicated in Section 9.2, "Operating Conditions\*\*", Section 9.4, "DC Specifications", or any other applicable section of this specification is not implied. Note, device signals are NOT 5 volt tolerant unless specified otherwise.

## 9.2 Operating Conditions\*\*

+3.3 V Supply Voltage (VDD33, VDDA33) ..... +3.0 V to 3.6 V

Power Supply Rise Time ..... [Note 9.4](#)

Ambient Operating Temperature in Still Air ( $T_A$ )..... [Note 9.5](#)

**Note 9.4** The power supply rise time requirements vary dependent on the usage of the external reset (RESET\_N). If RESET\_N is asserted at power-on, the power supply rise time must be 10mS or less ( $t_{RT(max)} = 10mS$ ). If RESET\_N is not used at power-on (tied high), the power supply rise time must be 1mS or less ( $t_{RT(max)} = 1mS$ ). [Figure 9.1](#) illustrates the supply rise time requirements.

**Note 9.5** 0°C to +70°C for commercial version, -40°C to +85°C for industrial version.

\*\*Proper operation of the device is guaranteed only within the ranges specified in this section.

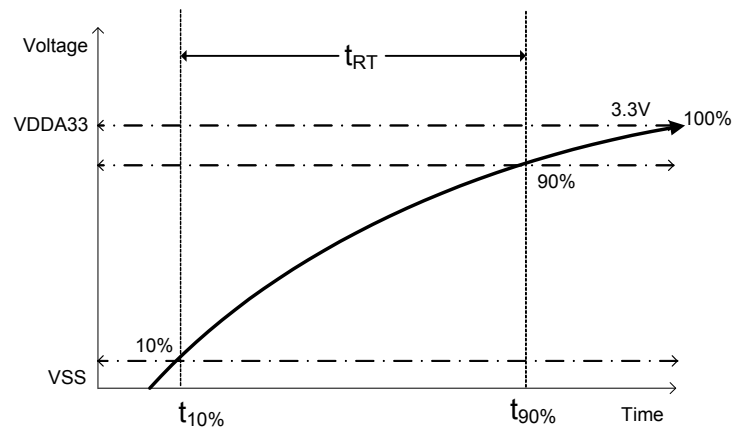

**Figure 9.1 Supply Rise Time Model**

## 9.3 Power Consumption

This section details the power consumption of the device as measured during various modes of operation. Power dissipation is determined by temperature, supply voltage, and external source/sink requirements.

### 9.3.1 Operational / Unconfigured

**Table 9.1 Operational/Unconfigured Power Consumption**

	TYPICAL (mA)	MAXIMUM (mA)
	VDD33	VDD33
HS Host / 1 HS Device	65	75
HS Host / 2 HS Devices	95	110
HS Host / 1 FS Device	45	50
HS Host / 2 FS Devices	50	60
Unconfigured	30	-

### 9.3.2 Suspend / Standby

**Table 9.2 Suspend/Standby Power Consumption**

MODE	SYMBOL	TYPICAL @ 25°C	COMMERCIAL MAX	INDUSTRIAL MAX	UNIT
Suspend	$I_{VDD33}$	320	1250	1750	uA
Standby	$I_{VDD33}$	75	130	140	uA

**Note:** Typical values measured with VDD33 = 3.3V. Maximum values measured with VDD33 = 3.6V.

## 9.4 DC Specifications

Table 9.3 DC Electrical Characteristics

PARAMETER	SYMBOL	MIN	TYP	MAX	UNITS	NOTES
<b>IS Type Input Buffer</b>						
Low Input Level	$V_{IL}$	-0.3		0.8	V	
High Input Level	$V_{IH}$	2.0		3.6	V	
<b>I_RST Type Input Buffer</b>						
Low Input Level	$V_{IL}$	-0.3		0.4	V	
High Input Level	$V_{IH}$	1.25		3.6	V	
<b>I_SMB Type Input Buffer</b>						
Low Input Level	$V_{IL}$	-0.3		0.35	V	
High Input Level	$V_{IH}$	1.25		3.6	V	
<b>O8 Type Buffers</b>						
Low Output Level	$V_{OL}$			0.4	V	$I_{OL} = 8 \text{ mA}$
High Output Level	$V_{OH}$	$V_{DD33} - 0.4$			V	$I_{OH} = -8 \text{ mA}$
<b>OD8 Type Buffer</b>						
Low Output Level	$V_{OL}$			0.4	V	$I_{OL} = 8 \text{ mA}$
<b>OD12 Type Buffer</b>						
Low Output Level	$V_{OL}$			0.4	V	$I_{OL} = 12 \text{ mA}$
<b>ICLK Type Buffer (XTAL1/REFCLK Input)</b>						
Low Input Level	$V_{IL}$	-0.3		0.35	V	
High Input Level	$V_{IH}$	0.8		$V_{DDCR12}$	V	

## 9.5 AC Specifications

This section details the various AC timing specifications of the device.

### 9.5.1 Power-On Configuration Strap Valid Timing

Figure 9.2 illustrates the configuration strap timing requirements, in relation to power-on, for applications where RESET\_N is not used at power-on. The operational level ( $V_{opp}$ ) for the external power supply is detailed in Section 9.2, "Operating Conditions\*\*," on page 52.

**Note:** For RESET\_N configuration strap timing requirements, refer to Section 9.5.2, "Reset and Configuration Strap Timing," on page 56.

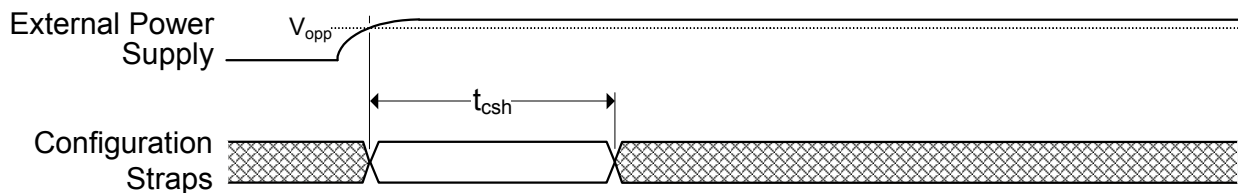

Figure 9.2 Power-On Configuration Strap Valid Timing

Table 9.4 Power-On Configuration Strap Valid Timing

SYMBOL	DESCRIPTION	MIN	TYP	MAX	UNITS
$t_{csh}$	Configuration strap hold after external power supply at operational level	1			ms

### 9.5.2 Reset and Configuration Strap Timing

Figure 9.3 illustrates the RESET\_N timing requirements and its relation to the configuration strap signals. Assertion of RESET\_N is not a requirement. However, if used, it must be asserted for the minimum period specified.

Refer to Section 8.3, "Resets," on page 47 for additional information on resets. Refer to Section 6.3, "Device Configuration Straps," on page 28 for additional information on configuration straps.

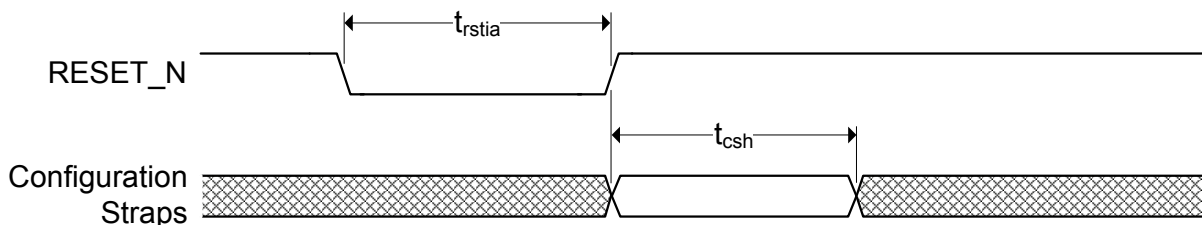

Figure 9.3 RESET\_N Configuration Strap Timing

Table 9.5 RESET\_N Configuration Strap Timing

SYMBOL	DESCRIPTION	MIN	TYP	MAX	UNITS
$t_{rstia}$	RESET_N input assertion time	5			us
$t_{csh}$	Configuration strap hold after RESET_N deassertion	1			ms

### 9.5.3 USB Timing

All device USB signals conform to the voltage, power, and timing characteristics/specifications as set forth in the *Universal Serial Bus Specification*. Please refer to the *Universal Serial Bus Specification*, Revision 2.0, available at <http://www.usb.org>.

### 9.5.4 SMBus Timing

All device SMBus signals conform to the voltage, power, and timing characteristics/specifications as set forth in the *System Management Bus Specification*. Please refer to the *System Management Bus Specification*, Version 1.0, available at <http://smbus.org/specs>.

### 9.5.5 I<sup>2</sup>C Timing

All device I<sup>2</sup>C signals conform to the 100KHz Standard Mode (Sm) voltage, power, and timing characteristics/specifications as set forth in the *I<sup>2</sup>C-Bus Specification*. Please refer to the *I<sup>2</sup>C-Bus Specification*, available at <http://www.nxp.com>.



## 9.6 Clock Specifications

The device can accept either a 24 MHz crystal or a 24 MHz single-ended clock oscillator input. If the single-ended clock oscillator method is implemented, XTAL1 should be left unconnected and REFCLK should be driven with a clock that adheres to the specifications outlined in [Section 9.6.2, "External Reference Clock \(REFCLK\)"](#).

### 9.6.1 Oscillator/Crystal

It is recommended that a crystal utilizing matching parallel load capacitors be used for the crystal input/output signals (XTAL1/XTAL2). See [Table 9.6](#) for the recommended crystal specifications.

**Table 9.6 Crystal Specifications**

PARAMETER	SYMBOL	MIN	NOM	MAX	UNITS	NOTES
Crystal Cut	AT, typ					
Crystal Oscillation Mode	Fundamental Mode					
Crystal Calibration Mode	Parallel Resonant Mode					
Frequency	$F_{fund}$	-	24.000	-	MHz	
Total Allowable PPM Budget		-	-	+/-350	PPM	
Operating Temperature Range		<a href="#">Note 9.6</a>	-	<a href="#">Note 9.7</a>	°C	

**Note 9.6** 0°C for commercial version, -40°C for industrial version.

**Note 9.7** +70°C for commercial version, +85°C for industrial version.

### 9.6.2 External Reference Clock (REFCLK)

The following input clock specifications are suggested:

- 50% duty cycle  $\pm$  10%
- 24 MHz  $\pm$  350 PPM

**Note:** The external clock is recommended to conform to the signalling levels designated in the JEDEC specification on 1.2V CMOS Logic. XTAL2 should be treated as a no connect when an external clock is supplied.

# Chapter 10 Package Outline

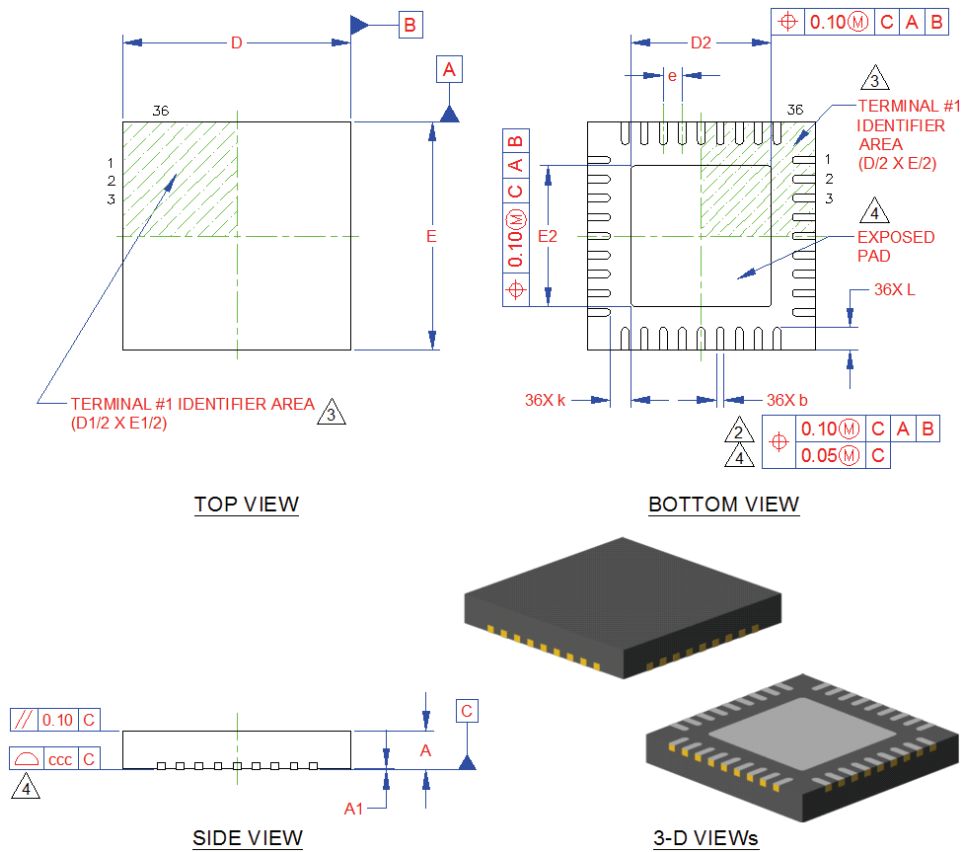

Figure 10.1 36-SQFN Package Drawing

Table 10.1 36-SQFN Package Dimensions

	MIN	NOMINAL	MAX	REMARKS
A	0.80	0.90	1.00	Overall Package Height
A1	0	0.02	0.05	Standoff
D/E	5.90	6.00	6.10	X/Y Body Size
D2/E2	3.60	3.70	3.80	X/Y Exposed Pad Size
L	0.50	0.60	0.75	Terminal Length
b	0.18	0.25	0.30	Terminal Width
k	0.45	0.55	-	Terminal to Exposed Pad Clearance
ccc	-	-	0.08	Coplanarity
e	0.50 BSC			Terminal Pitch

**Notes:**

1. All dimensions are in millimeters unless otherwise noted.
2. Dimension "b" applies to plated terminals and is measured between 0.15 and 0.30 mm from the terminal tip.
3. The pin 1 identifier may vary, but is always located within the zone indicated.
4. Coplanarity zone applies to exposed pad and terminals.

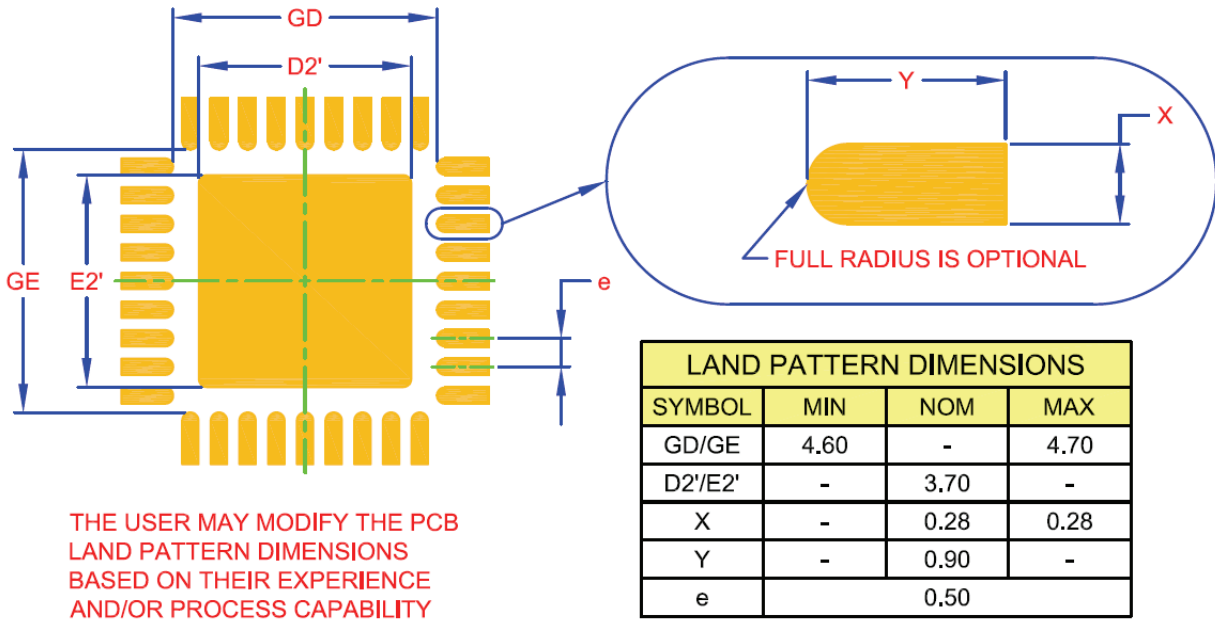

Figure 10.2 36-SQFN Package Recommended Land Pattern

## Chapter 11 Datasheet Revision History

Table 11.1 Revision History

REVISION LEVEL & DATE	SECTION/FIGURE/ENTRY	CORRECTION
Rev. 1.0 (06-17-13)	Initial Release	

Компания «Океан Электроники» предлагает заключение долгосрочных отношений при поставках импортных электронных компонентов на взаимовыгодных условиях!

Наши преимущества:

- Поставка оригинальных импортных электронных компонентов напрямую с производств Америки, Европы и Азии, а так же с крупнейших складов мира;
- Широкая линейка поставок активных и пассивных импортных электронных компонентов (более 30 млн. наименований);
- Поставка сложных, дефицитных, либо снятых с производства позиций;
- Оперативные сроки поставки под заказ (от 5 рабочих дней);
- Экспресс доставка в любую точку России;
- Помощь Конструкторского Отдела и консультации квалифицированных инженеров;
- Техническая поддержка проекта, помощь в подборе аналогов, поставка прототипов;
- Поставка электронных компонентов под контролем ВП;
- Система менеджмента качества сертифицирована по Международному стандарту ISO 9001;
- При необходимости вся продукция военного и аэрокосмического назначения проходит испытания и сертификацию в лаборатории (по согласованию с заказчиком);
- Поставка специализированных компонентов военного и аэрокосмического уровня качества (Xilinx, Altera, Analog Devices, Intersil, Interpoint, Microsemi, Actel, Aeroflex, Peregrine, VPT, Syfer, Eurofarad, Texas Instruments, MS Kennedy, Miteq, Cobham, E2V, MA-COM, Hittite, Mini-Circuits, General Dynamics и др.);

Компания «Океан Электроники» является официальным дистрибьютором и эксклюзивным представителем в России одного из крупнейших производителей разъемов военного и аэрокосмического назначения «JONHON», а так же официальным дистрибьютором и эксклюзивным представителем в России производителя высокотехнологичных и надежных решений для передачи СВЧ сигналов «FORSTAR».



## JONHON

«JONHON» (основан в 1970 г.)

Разъемы специального, военного и аэрокосмического назначения:

(Применяются в военной, авиационной, аэрокосмической, морской, железнодорожной, горно- и нефтедобывающей отраслях промышленности)

«FORSTAR» (основан в 1998 г.)

ВЧ соединители, коаксиальные кабели,  
кабельные сборки и микроволновые компоненты:

(Применяются в телекоммуникациях гражданского и специального назначения, в средствах связи, РЛС, а так же военной, авиационной и аэрокосмической отраслях промышленности).



Телефон: 8 (812) 309-75-97 (многоканальный)

Факс: 8 (812) 320-03-32

Электронная почта: [ocean@oceanchips.ru](mailto:ocean@oceanchips.ru)

Web: <http://oceanchips.ru/>

Адрес: 198099, г. Санкт-Петербург, ул. Калинина, д. 2, корп. 4, лит. А