



---

## MIC58P42

---

### 8-Bit Serial-Input Protected Latched Driver

---

#### General Description

The MIC58P42 serial-input latched driver is a high-voltage (80V), high-current (500mA) integrated circuit comprised of eight CMOS data latches, a bipolar Darlington transistor driver for each latch, and CMOS control circuitry for the common STROBE, CLOCK, SERIAL DATA INPUT, and OUTPUT ENABLE functions. Similar to the MIC5842, additional protection circuitry supplied on this device includes thermal shutdown, under voltage lockout (UVLO), and overcurrent shutdown.

The bipolar/CMOS combination provides an extremely low-power latch with maximum interface flexibility. The MIC58P42 has open-collector outputs capable of sinking 500 mA and integral diodes for inductive load transient suppression with a minimum output breakdown voltage rating of 80V (50V sustaining). The drivers can be operated with a split supply, where the negative supply is down to -20V and may be paralleled for higher load current capability.

With a 5V logic supply, the MIC58P42 will typically operate at better than 5MHz. With a 12V logic supply, significantly higher speeds are obtained. The CMOS inputs are compatible with standard CMOS, PMOS, and NMOS circuits. TTL circuits may require pull-up resistors. By using the serial data output, drivers may be cascaded for interface applications requiring additional drive lines.

Each of these eight outputs has an independent over current shutdown of 500 mA. Upon over-current detection, the affected channel will turn OFF until VDD is cycled or the ENABLE/RESET pin is pulsed high. Current pulses less than 2 $\mu$ s will not activate current shutdown. Temperatures above 165°C will shut down the device. The UVLO circuit prevents operation at low VDD; hysteresis of 0.5V is provided. See the MIC59P60 for a similar device that additionally provides an error flag output.

Datasheets and support documentation are available on Micrel's web site at: [www.micrel.com](http://www.micrel.com).

#### Features

- 3.3 MHz Minimum Data-Input Rate
- CMOS, PMOS, NMOS, and TTL Compatible
- Internal Pull-Up/Pull-Down Resistors
- Low Power CMOS Logic and Latches
- High Voltage (80V) Current-Sink Outputs
- Output Transient-Protection Diodes
- Single or Split Supply Operation
- Thermal Shutdown
- Under-Voltage Lockout
- Per-Output Over-Current Shutdown (500mA typical)

### Functional Diagram

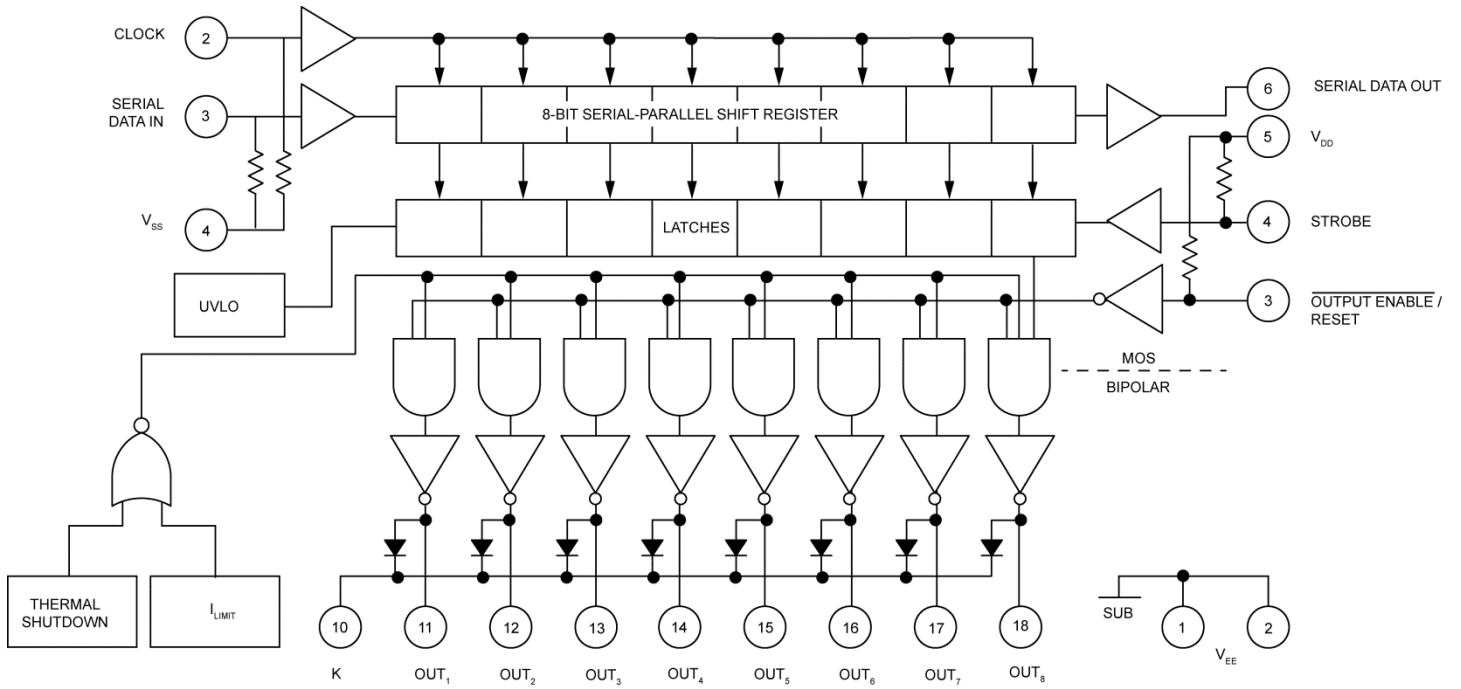

### Ordering Information

Part Number	Junction Temperature Range	Package	Pb-Free
MIC58P42YN	-40°C to +85°C	18-Pin Plastic DIP	√
MIC58P42YV	-40°C to +85°C	20-Pin PLCC	√
MIC58P42YWM	-40°C to +85°C	18-Pin Wide SOIC	√

### Pin Configuration

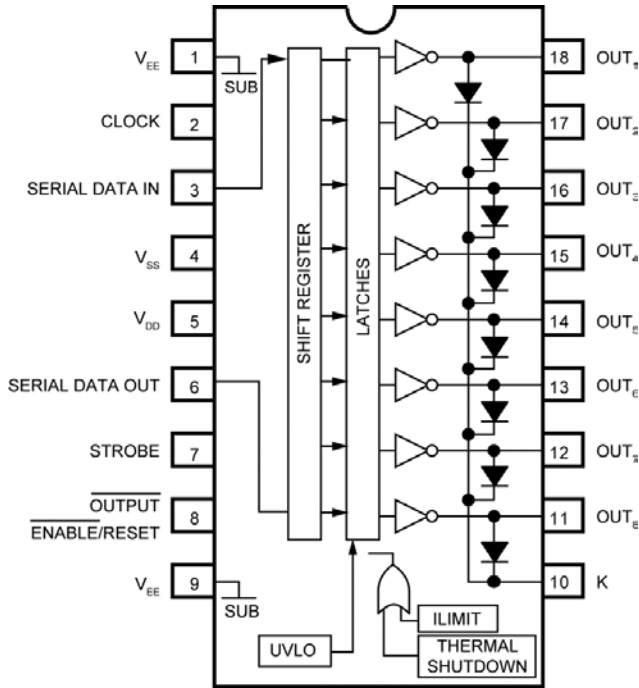

18-pin DIP (N) and 18-pin Wide SOIC (WM)  
(Top View)

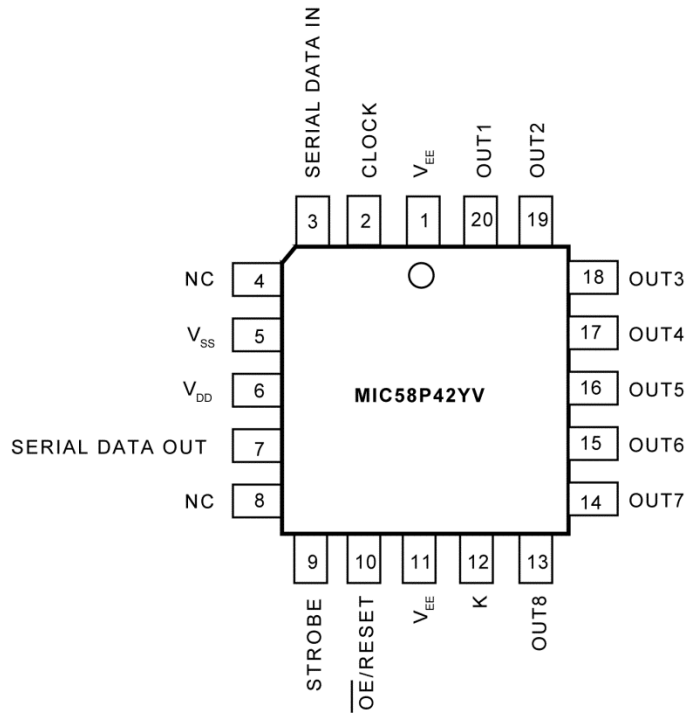

20-pin PLCC (V)  
(Top View)

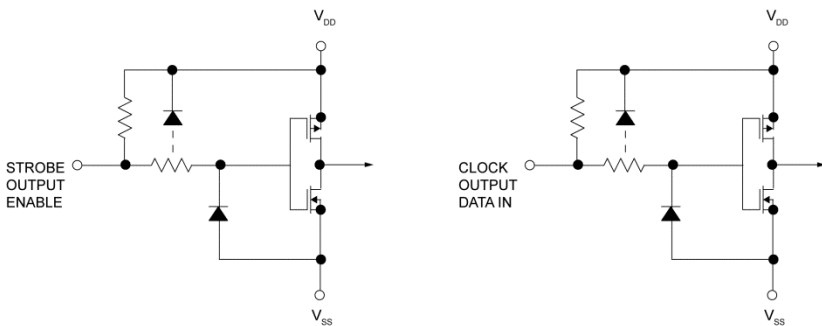

Typical Input Circuits

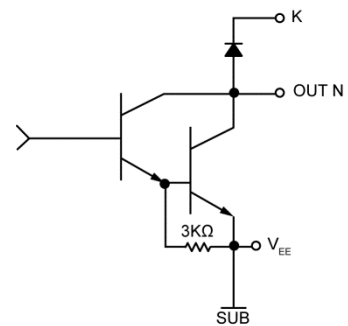

Typical Output Driver

## Pin Description

Pin Number DIP & SOIC	Pin Number PLCC	Pin Name	Pin Function
1, 9	1, 11	$V_{EE}$	Substrate. Most Negative voltage in the system connects here.
2	2	CLOCK	Serial Data Clock. A CLEAR input must also be clocked into the latches.
3	3	SERIAL DATA IN	Serial Data Input pin.
4	5	$V_{SS}$	Logic reference (Ground) pin.
5	6	$V_{DD}$	Logic Positive Supply voltage.
6	7	SERIAL DATA OUT	Serial Data Output pin. (Flow-through).
7	9	STROBE	Output Strobe pin. Loads output latches when high. Strobe is needed to clear latch.
8	10	$\overline{\text{OUTPUT}}ENABLE/RESET$	When Low, Outputs are active. When High, device is reset from a fault condition.
10	12	K	Transient suppression diode's cathode common pin.
11 – 18	13 – 20	$OUT_N$	Open Collector outputs 8 through 1.

### Absolute Maximum Ratings<sup>(1)</sup>

Output Voltage .....	+80V
Output Voltage, $V_{CE(SUS)}$ <sup>(3)</sup> .....	+50V
Logic Supply Voltage Range ( $V_{DD}$ ) .....	4.5V to 15V
$V_{DD}$ with reference to $V_{EE}$ .....	25V
Emitter Supply Voltage (Substrate) ( $V_{EE}$ ) .....	-20V
Input Voltage Range ( $V_{IN}$ ) .....	-0.3V to $V_{DD} + 0.3V$
Operating Temperature Range ( $T_A$ ) .....	-65°C to +125°C
Storage Temperature Range ( $T_S$ ) .....	-60°C to +150°C
ESD Rating <sup>(4)</sup> .....	ESD Sensitive

### Operating Ratings<sup>(2)</sup>

Package Power Dissipation, $P_D$	
MIC58P42YN .....	1.82W
Derate above $T_A = +25^\circ C$ .....	18mW/°C
MIC58P42YV .....	1.4W
Derate above $T_A = +25^\circ C$ .....	14mW/°C
MIC58P42YWM .....	1.2W
Derate above $T_A = +25^\circ C$ .....	12mW/°C
Operating Temperature Range ( $T_A$ ) .....	-40°C to +85°C

### Electrical Characteristics<sup>(5)</sup>

$T_A = 25^\circ C$ ,  $V_{DD} = 5V$ ;  $V_{SS} = V_{EE} = 0V$ , unless otherwise noted.

Symbol	Parameter	Condition	Min.	Typ.	Max.	Units
$I_{CEX}$	Output Leakage Current	$V_{OUT} = 80V$			50	$\mu A$
		$V_{OUT} = 80V, T_A = +70^\circ C$			100	
$V_{CE(SAT)}$	Collector-Emitter Saturation Voltage	$I_{OUT} = 100mA$ $I_{OUT} = 200mA$ $I_{OUT} = 350mA$		0.9 1.1 1.3	1.1 1.3 1.6	V
$V_{CE(SUS)}$	Collector-Emitter Sustaining Voltage	$I_{OUT} = 350mA, L = 2mH$	50			V
$V_{IN(0)}$	Input Voltage (Low)				1.0	V
$V_{IN(1)}$	Input Voltage (High)	$V_{DD} = 12V$ $V_{DD} = 10V$ $V_{DD} = 5.0V, \text{Note 6}$		10.5 8.5 3.5		
$R_{IN}$	Input Resistance	$V_{DD} = 12V$	50	200		k $\Omega$
		$V_{DD} = 10V$	50	300		
		$V_{DD} = 5.0V$	50	600		
$I_{DD(ON)}$	Supply Current	All Drivers ON, $V_{DD} = 12V$		6.4	10.0	mA
		All Drivers ON, $V_{DD} = 10V$		6.0	9.0	
		All Drivers ON, $V_{DD} = 5.0V$		4.6	7.5	
$I_{DD(1 ON)}$		One Driver ON, All others OFF, $V_{DD} = 12V$		3.1	4.5	
	One Driver ON, All others OFF, $V_{DD} = 10V$		2.9	4.5		
	One Driver ON, All others OFF, $V_{DD} = 5.0V$		2.3	3.6		
$I_{DD(OFF)}$	All Drivers OFF, $V_{DD} = 12V$			2.6	4.2	
	All Drivers OFF, $V_{DD} = 10V$			2.4	3.6	
	All Drivers OFF, $V_{DD} = 5.0V$			1.9	3.0	

**Notes:**

- Exceeding the absolute maximum ratings may damage the device.
- The device is not guaranteed to function outside its operating ratings.
- For inductive load applications.
- Devices are ESD sensitive. Handling precautions are recommended. Human body model, 1.5k $\Omega$  in series with 100pF.
- Specification for packaged product only.
- Operation of these devices with standard TTL or DTL may require the use of appropriate pull-up resistors to insure a minimum logic "1".

**Electrical Characteristics (Continued)**

Symbol	Parameter	Condition	Min.	Typ.	Max.	Units
$I_R$	Clamp Diode Leakage Current	$V_R = 80V$			50	$\mu A$
$V_F$	Clamp Diode Forward Voltage	$I_F = 350mA$		1.7	2.0	V
$I_{LIM}$	Output Current Shutdown Threshold			500		mA
$V_{SU}$	Start Up Voltage	Note 7	3.5	4.0	4.5	V
$V_{DD MIN}$	Minimum Supply ( $V_{DD}$ )		3.0	3.5	4.0	V
	Thermal Shutdown			165		$^{\circ}C$
	Thermal Shutdown Hysteresis			10		$^{\circ}C$

**Note:**

7. Undervoltage Lockout is guaranteed to release device at no more than 4.5V, and disable the device at no less than 3.0V.

## Timing Diagram

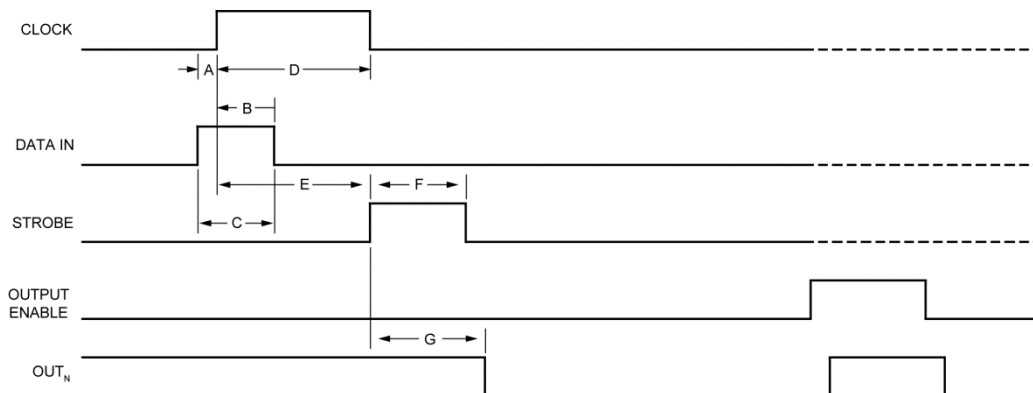

## Timing Conditions

(T<sub>A</sub> = +25°C, Logic Levels are V<sub>DD</sub> and V<sub>SS</sub>), V<sub>DD</sub> = 5V

A. Typical Data Active Time Before Clock Pulse (Data Set-Up Time).....	75ns
B. Minimum Data Active Time After Clock Pulse (Data Hold Time). ....	75ns
C. Minimum Data Pulse Width .....	150ns
D. Minimum Clock Pulse Width .....	150ns
E. Minimum Time Between Clock Activation and Strobe.....	300ns
F. Minimum Strobe Pulse Width .....	100ns
G. Typical Time Between Strobe Activation and Output Transition .....	500ns

SERIAL DATA present at the input is transferred to the shift register on the logic “0” to logic “1” transition of the CLOCK input pulse. On succeeding CLOCK pulses, the registers shift data information towards the SERIAL DATA OUTPUT. The SERIAL DATA must appear at the input prior to the rising edge of the CLOCK input waveform.

Information present at any register is transferred to its respective latch when the STROBE is high (serial-to-parallel conversion). The latches will continue to accept new data as long as the STROBE is held high. Applications where the latches are bypassed (STROBE tied high) will require that the ENABLE input be high to prevent invalid output states.

When the ENABLE input is high, all of the output buffers are disabled (OFF) without affecting information stored in the latches or shift register. With the ENABLE input low, the outputs are controlled by the state of the latches. A positive OUTPUT ENABLE/ RESET pulse resets the output after a current shutdown fault. Thermal limit faults are not latched and require no reset pulse.

### MIC58P42 Truth Table

Serial Data Input	Clock Input	Shift Register Contents	Serial Data Output	Strobe Input	Latch Contents	Output Enable	Output Contents
		I <sub>1</sub> I <sub>2</sub> I <sub>3</sub> ..... I <sub>8</sub>			I <sub>1</sub> I <sub>2</sub> I <sub>3</sub> ..... I <sub>8</sub>		I <sub>1</sub> I <sub>2</sub> I <sub>3</sub> ..... I <sub>8</sub>
H	┌	H R <sub>1</sub> R <sub>2</sub> ..... R <sub>7</sub>	R <sub>7</sub>				
L	┐	L R <sub>1</sub> R <sub>2</sub> ..... R <sub>7</sub>	R <sub>7</sub>				
X	└	R <sub>1</sub> R <sub>2</sub> R <sub>3</sub> ..... R <sub>8</sub>	R <sub>8</sub>				
	┌	O O O ..... O	L				
		X X X ..... X	X	L	R <sub>1</sub> R <sub>2</sub> R <sub>3</sub> ..... R <sub>8</sub>		
		P <sub>1</sub> P <sub>2</sub> P <sub>3</sub> ..... P <sub>8</sub>	P <sub>8</sub>	H	P <sub>1</sub> P <sub>2</sub> P <sub>3</sub> ..... P <sub>8</sub>	L	P <sub>1</sub> P <sub>2</sub> P <sub>3</sub> ..... P <sub>8</sub>
					X X X ..... X	H	H H H ..... H

L = Low Level Logic  
 H = High Level Logic  
 X = Irrelevant  
 P = Present State  
 R = Previous State  
 O = Output OFF



# Typical Characteristics

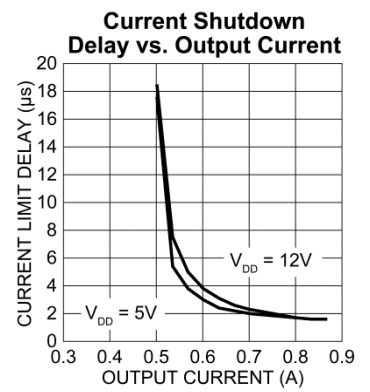
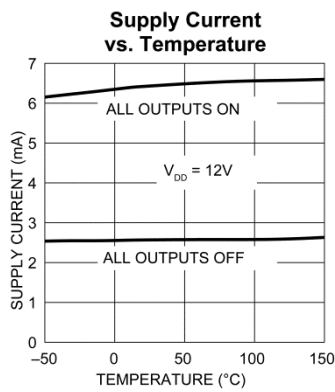
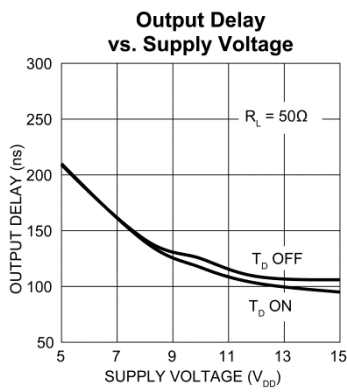
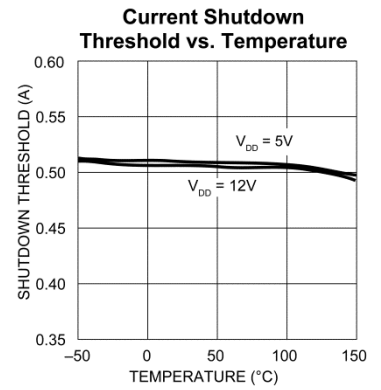
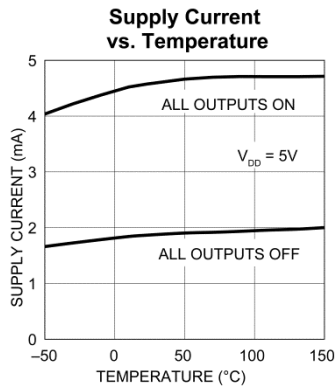
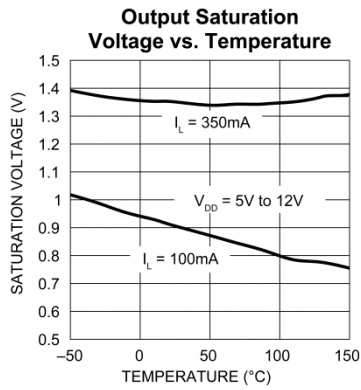

## Maximum Allowable Duty Cycle, Plastic DIP

$V_{DD} = 5.0V$

Number of Outputs ON ( $I_{OUT} = 200mA$ $V_{DD} = 5.0V$ )	Max. Allowable Duty Cycle at Ambient Temperatures				
	25°C	40°C	50°C	60°C	70°C
8	85%	72%	64%	55%	46%
7	97%	82%	73%	63%	53%
6	100%	96%	85%	73%	62%
5	100%	100%	100%	88%	75%
4	100%	100%	100%	100%	93%
3	100%	100%	100%	100%	100%
2	100%	100%	100%	100%	100%
1	100%	100%	100%	100%	100%

$V_{DD} = 12V$

Number of Outputs ON ( $I_{OUT} = 200mA$ $V_{DD} = 12V$ )	Max. Allowable Duty Cycle at Ambient Temperatures				
	25°C	40°C	50°C	60°C	70°C
8	80%	68%	60%	52%	44%
7	91%	77%	68%	59%	50%
6	100%	90%	79%	69%	58%
5	100%	100%	95%	82%	69%
4	100%	100%	100%	100%	86%
3	100%	100%	100%	100%	100%
2	100%	100%	100%	100%	100%
1	100%	100%	100%	100%	100%

## Package Information and Recommended Landing Pattern<sup>(8)</sup>

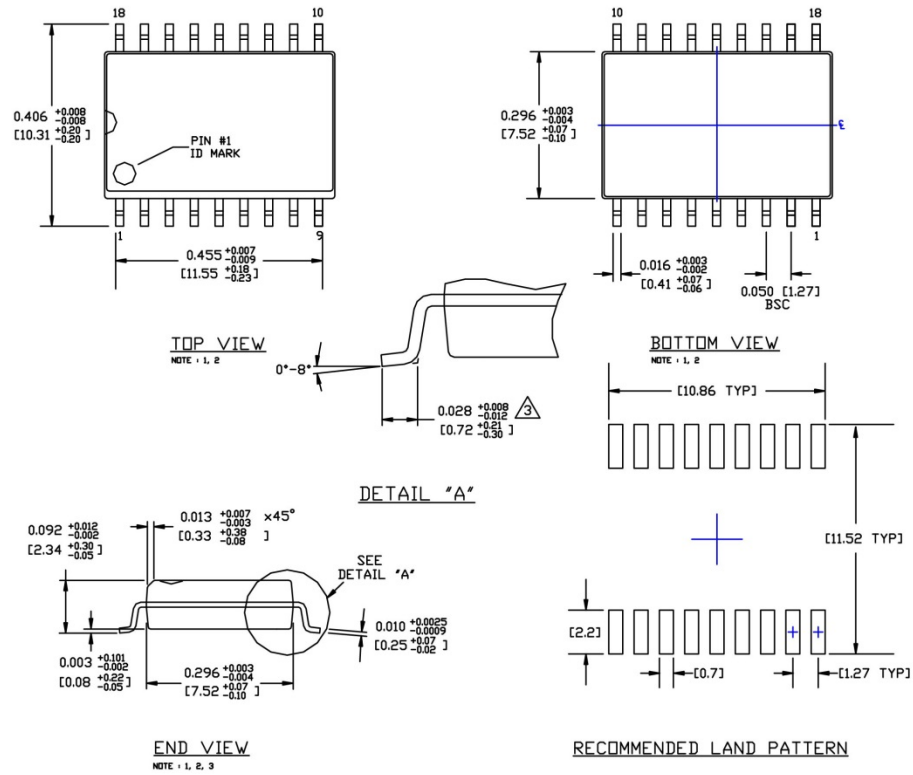

- NOTES:**
1. DIMENSIONS ARE IN INCHES[MM].
  2. CONTROLLING DIMENSION: INCHES.
  3. DIMENSION DOES NOT INCLUDE MOLD FLASH OR PROTRUSIONS, EITHER OF WHICH SHALL NOT EXCEED 0.006[0.15] PER SIDE.

### 18-Pin Wide SOIC (WM)

**Note:**

8. Package information is correct as of the publication date. For updates and most current information, go to [www.micrel.com](http://www.micrel.com).

### Package Information and Recommended Landing Pattern<sup>(8)</sup> Continued

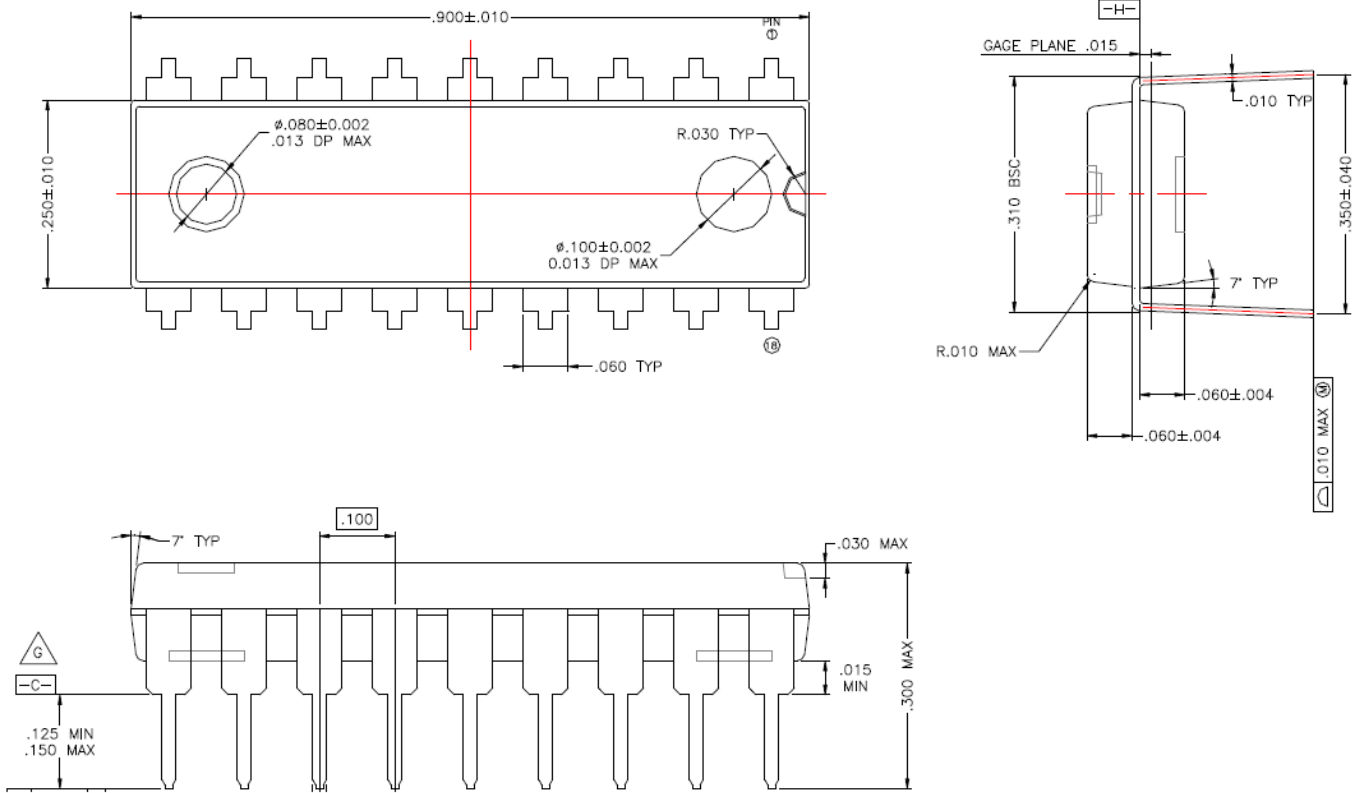

18-Pin DIP (N)

Package Information and Recommended Landing Pattern<sup>(8)</sup> Continued

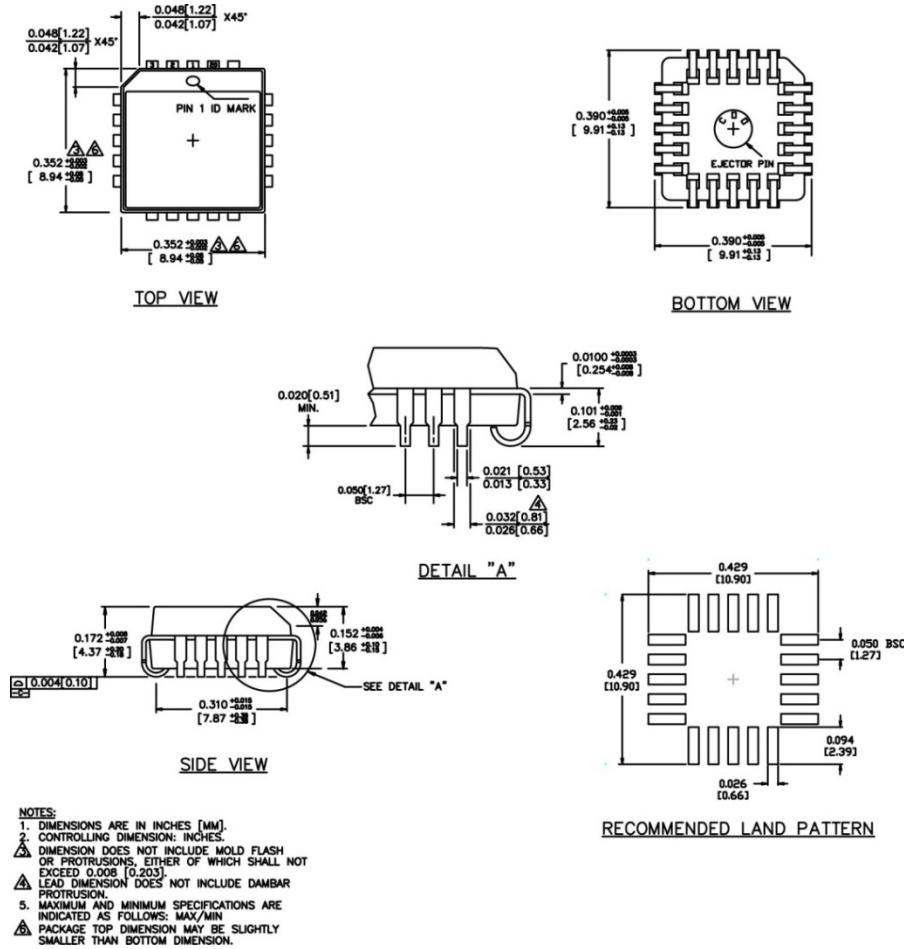

20-Pin PLCC (V)

MICREL, INC. 2180 FORTUNE DRIVE SAN JOSE, CA 95131 USA  
 TEL +1 (408) 944-0800 FAX +1 (408) 474-1000 WEB <http://www.micrel.com>

Micrel, Inc. is a leading global manufacturer of IC solutions for the worldwide high performance linear and power, LAN, and timing & communications markets. The Company's products include advanced mixed-signal, analog & power semiconductors; high-performance communication, clock management, MEMS-based clock oscillators & crystal-less clock generators, Ethernet switches, and physical layer transceiver ICs. Company customers include leading manufacturers of enterprise, consumer, industrial, mobile, telecommunications, automotive, and computer products. Corporation headquarters and state-of-the-art wafer fabrication facilities are located in San Jose, CA, with regional sales and support offices and advanced technology design centers situated throughout the Americas, Europe, and Asia. Additionally, the Company maintains an extensive network of distributors and reps worldwide.

Micrel makes no representations or warranties with respect to the accuracy or completeness of the information furnished in this datasheet. This information is not intended as a warranty and Micrel does not assume responsibility for its use. Micrel reserves the right to change circuitry, specifications and descriptions at any time without notice. No license, whether express, implied, arising by estoppel or otherwise, to any intellectual property rights is granted by this document. Except as provided in Micrel's terms and conditions of sale for such products, Micrel assumes no liability whatsoever, and Micrel disclaims any express or implied warranty relating to the sale and/or use of Micrel products including liability or warranties relating to fitness for a particular purpose, merchantability, or infringement of any patent, copyright, or other intellectual property right.

Micrel Products are not designed or authorized for use as components in life support appliances, devices or systems where malfunction of a product can reasonably be expected to result in personal injury. Life support devices or systems are devices or systems that (a) are intended for surgical implant into the body or (b) support or sustain life, and whose failure to perform can be reasonably expected to result in a significant injury to the user. A Purchaser's use or sale of Micrel Products for use in life support appliances, devices or systems is a Purchaser's own risk and Purchaser agrees to fully indemnify Micrel for any damages resulting from such use or sale.

© 2015 Micrel, Incorporated.

Компания «Океан Электроники» предлагает заключение долгосрочных отношений при поставках импортных электронных компонентов на взаимовыгодных условиях!

Наши преимущества:

- Поставка оригинальных импортных электронных компонентов напрямую с производств Америки, Европы и Азии, а так же с крупнейших складов мира;
- Широкая линейка поставок активных и пассивных импортных электронных компонентов (более 30 млн. наименований);
- Поставка сложных, дефицитных, либо снятых с производства позиций;
- Оперативные сроки поставки под заказ (от 5 рабочих дней);
- Экспресс доставка в любую точку России;
- Помощь Конструкторского Отдела и консультации квалифицированных инженеров;
- Техническая поддержка проекта, помощь в подборе аналогов, поставка прототипов;
- Поставка электронных компонентов под контролем ВП;
- Система менеджмента качества сертифицирована по Международному стандарту ISO 9001;
- При необходимости вся продукция военного и аэрокосмического назначения проходит испытания и сертификацию в лаборатории (по согласованию с заказчиком);
- Поставка специализированных компонентов военного и аэрокосмического уровня качества (Xilinx, Altera, Analog Devices, Intersil, Interpoint, Microsemi, Actel, Aeroflex, Peregrine, VPT, Syfer, Eurofarad, Texas Instruments, MS Kennedy, Miteq, Cobham, E2V, MA-COM, Hittite, Mini-Circuits, General Dynamics и др.);

Компания «Океан Электроники» является официальным дистрибьютором и эксклюзивным представителем в России одного из крупнейших производителей разъемов военного и аэрокосмического назначения «**JONHON**», а так же официальным дистрибьютором и эксклюзивным представителем в России производителя высокотехнологичных и надежных решений для передачи СВЧ сигналов «**FORSTAR**».



## JONHON

«**JONHON**» (основан в 1970 г.)

Разъемы специального, военного и аэрокосмического назначения:

(Применяются в военной, авиационной, аэрокосмической, морской, железнодорожной, горно- и нефтедобывающей отраслях промышленности)

«**FORSTAR**» (основан в 1998 г.)

ВЧ соединители, коаксиальные кабели,  
кабельные сборки и микроволновые компоненты:

(Применяются в телекоммуникациях гражданского и специального назначения, в средствах связи, РЛС, а так же военной, авиационной и аэрокосмической отраслях промышленности).



Телефон: 8 (812) 309-75-97 (многоканальный)

Факс: 8 (812) 320-03-32

Электронная почта: [ocean@oceanchips.ru](mailto:ocean@oceanchips.ru)

Web: <http://oceanchips.ru/>

Адрес: 198099, г. Санкт-Петербург, ул. Калинина, д. 2, корп. 4, лит. А