

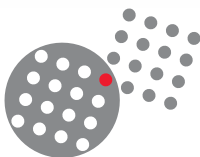

# UTS Series

Dynamic IP68/69K • UV Resistant • UL/IEC Compliant



**SOURIAU**





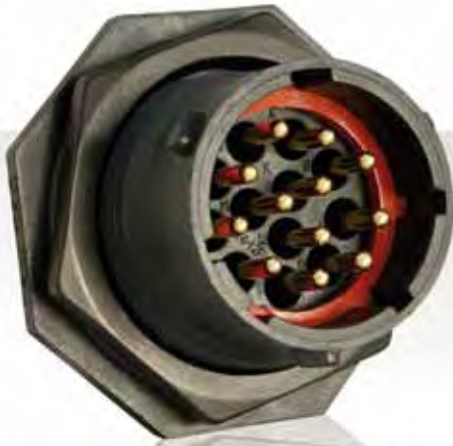

## Contents

### Overview

How to read our catalogue .....	06
UTS range overview .....	07
General technical characteristics .....	10

### Mechanics

Cable assembly.....	14
2 contacts .....	20
2 + ground contacts .....	28
3 contacts .....	36
3 + ground contacts .....	52
4 contacts .....	60
5 contacts .....	72
6 contacts .....	76
6 + ground contacts .....	88
7 contacts .....	92
8 contacts .....	96
10 contacts .....	104
12 contacts .....	108
14 contacts .....	116
15 contacts .....	120
18 contacts .....	124
19 contacts .....	128
23 contacts .....	132
32 contacts .....	136

### Contacts

Description .....	142
Contact plating selector guide .....	143
Contact selector guide .....	144
Packaging .....	144
Crimp contacts .....	145
#16 coaxial contacts .....	147
PCB contacts .....	148
Fibre optic contacts .....	149

### Technical information

Tooling .....	154
Assembly instruction .....	156
Dimensions overmoulded harnesses .....	162
Extraction tools .....	162
Rated current & working voltage .....	163
UV resistance .....	164
UL94 + UL1977 .....	165
IEC 61984 with IP code explanation .....	168
What is NEMA rating ? .....	170
Ethernet for the layman .....	171

### Appendices

#16 coaxial contacts - cabling notices .....	176
Glossary of terms .....	183
Discrimination/Keying methods .....	184
Part number Index.....	185



UNIT'S  
Series

UTS Series

# Overview

- How to read our catalog ..... 06
- UTS range overview ..... 07
- General technical characteristics ..... 10



# UTS Series

## Overview



SOURIAU is pleased to announce the arrival of a brand new catalog containing some significant improvements to simplify the connector selection process and provide easy access to key information. In this version you can see all layouts at a glance, download 2D drawings and 3D models. Then, when your choice is made, you can click on the part number and buy online.

### Step 1

Interactive zones.

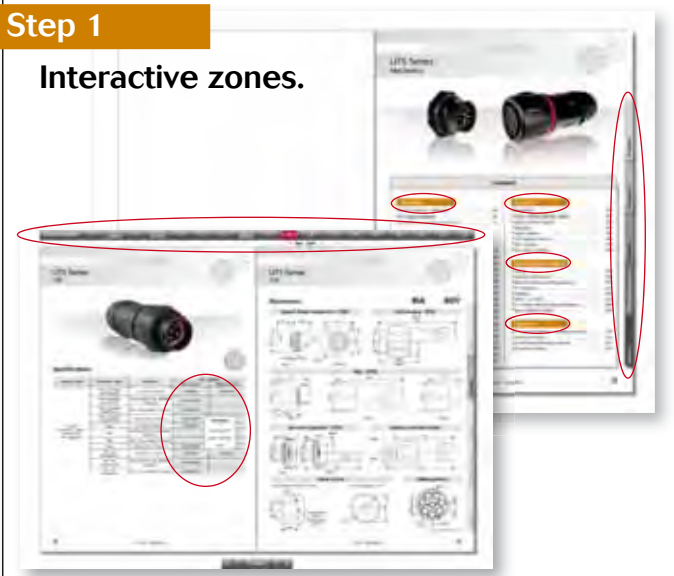

### Step 2

Clearer understanding of the range.

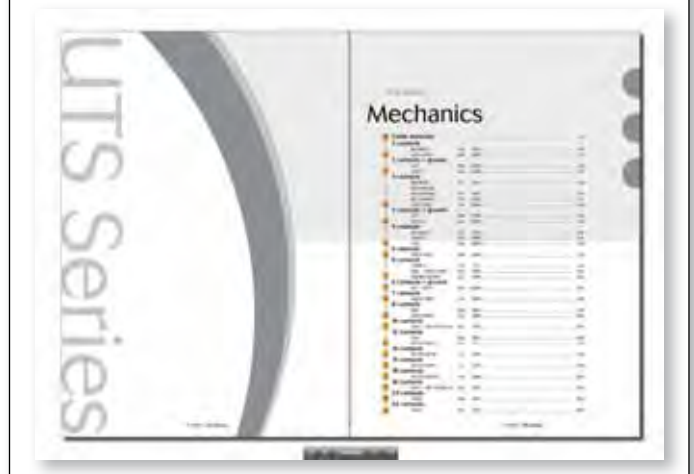

### Step 3

Easy access to supporting material such as prints and CAD models. In just two pages you can gather together details of all accessories, contacts, tools etc required for your application.





## UTS range overview

**The UTS series is a plastic connector range but rugged enough to withstand industrial applications.**

The bayonet coupling system makes it simple to use. With only a 1/3 twist of the coupling ring, connectors are mated with an audible and sensitive "click".



**UTS series is a wide range...**

Based on multiple power & signal connectors and offers everything from box mounted receptacles and cable mounted plugs to cable mounted in-line and PCB mounted receptacles. Almost all ways to accommodate wires exist: Crimp, Solder, Screw termination.



Screw termination version

**The philosophy of the UTS series is built around three key elements:**

### Dynamic IP68/69K



UTS series is rated at IP68/69K... even in dynamic conditions. This means that it remain sealed even when used continuously underwater or cleaned using a high pressure hose and cable is moving.

This extreme level of performance is achievable with jacketed cable or discrete wires.

If this same level of performance is required even when connectors are not mated, we have UTS Hi Seal; a product designed to remain watertight if an environmental cap is not fitted or if the equipment is likely to get wet when cables have been disconnected.

### UV Resistant



In most applications, our connectors are exposed to extreme climatic conditions; it was therefore key for us to select the materials best able to cope with the targeted environment.

Part of our product qualification process involved subjecting connectors to a simulated five years of exposure to various elements including Temperature, UV and Humidity.

The results were positive in that there were no visible signs of weakness, such as cracking or crazing.

### UL/IEC Compliant



The outmost priority for any electrical installation is to protect personnel from any shock hazard.

In North America, Underwriters Laboratories insisted that connector manufacturers, depending of the application, respect their standards. The UTS series had thus been qualified and is certified by this organisation.

In Europe and in Asia, IEC standards are better known and trusted by end users. Like its American equivalent, the IEC refers to safety rules. The UTS series was obviously designed to respect these rules.



# UTS Series Overview



## UTS range

### UTS discrete wire sealing

See page 9

### UTS Series



Sealed: IP68/69K  
UV resistant  
UL/IEC compliant

Corrosion-proof  
Plastic housing

### UTS screw termination



Just screw the wires to the connector !

No special tools required, use a standard screwdriver

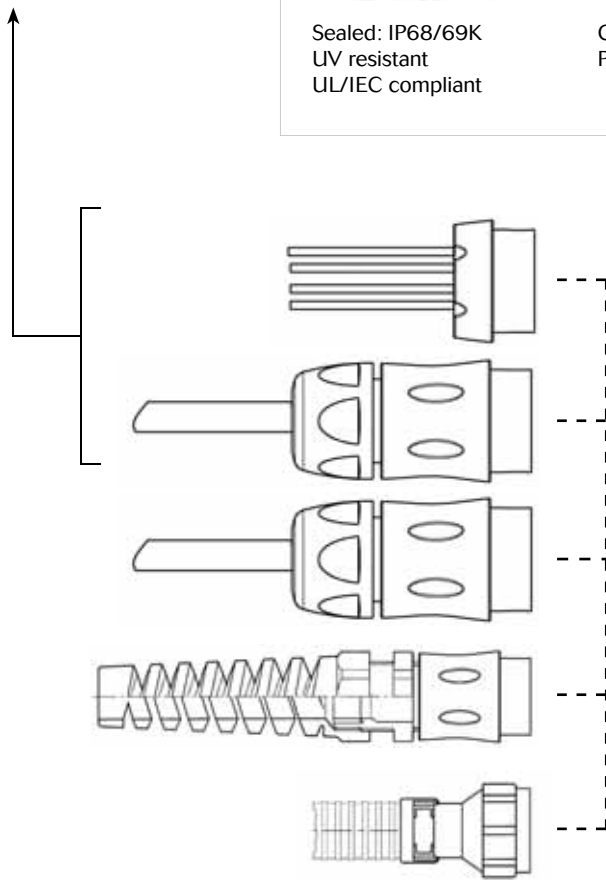

### Crimp contact

- machined
- stamped and formed
- coaxial
- fibre optics



### Screw termination contact

### Solder contact

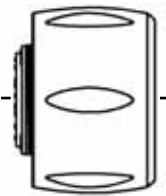

### Plug

### UTS Hi seal

### Sealed Unmated

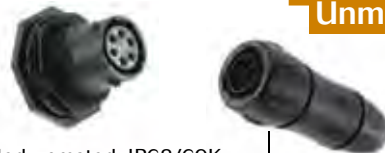

Sealed unmated: IP68/69K  
MIL-C-26482 compatible  
UV resistant  
UL/IEC compliant

Corrosion-proof  
Plastic housing

# UTS Series Overview



## overview

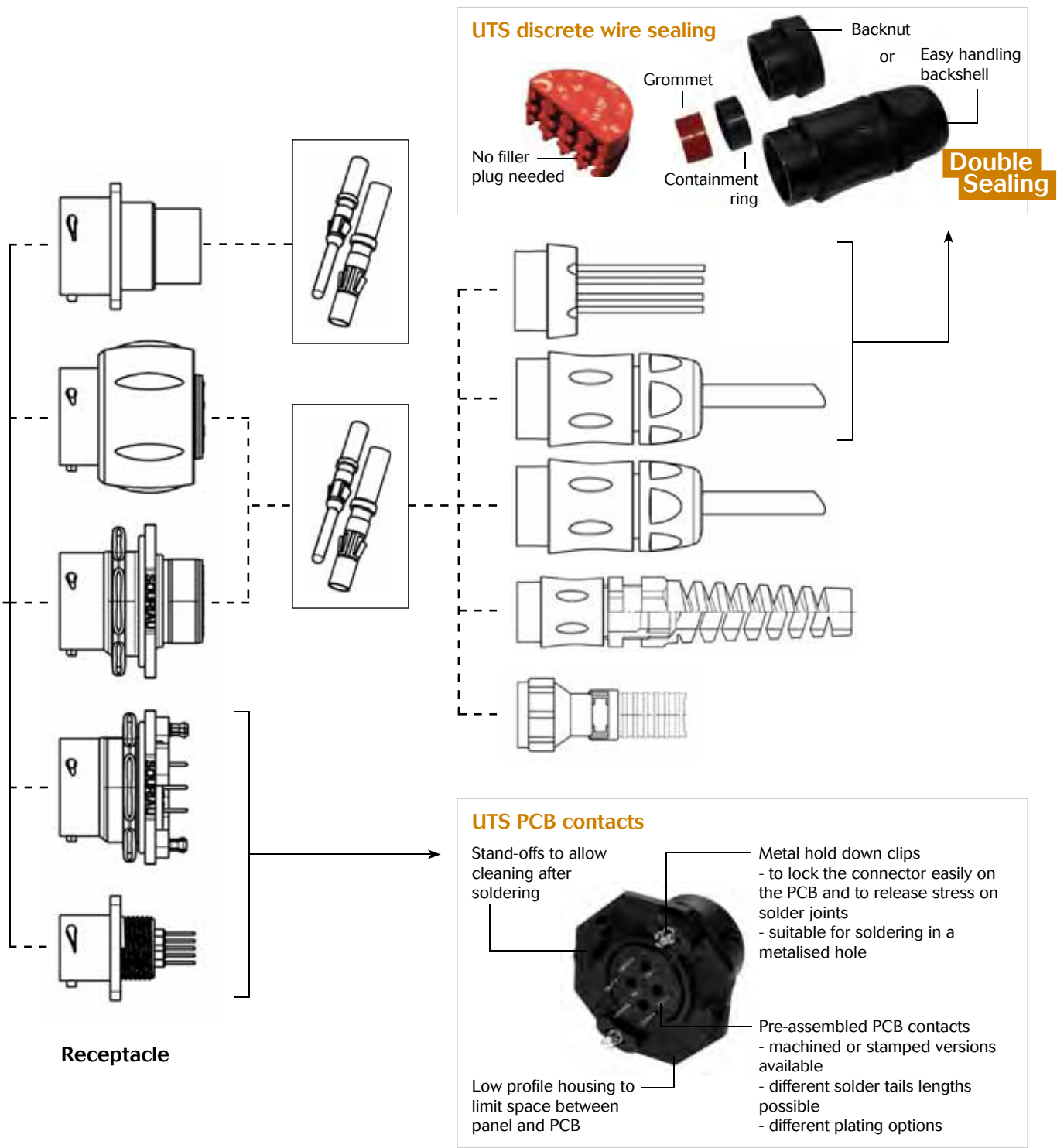



### Mechanical

- Durability:  
250 matings & unmatings per MIL-C-26482
- 1 • Vibration resistance (all UTS versions except UTS Screw termination contacts):  
Sinusoidal vibrations per CEI 60512-4 - from 10 to 2000 Hz
- Thermal shock:  
5 cycles 30 min. from -40°C to 105°C per MIL-STD1344 method 1003

### Environmental

- 2 • Operating temperature:  
from -40°C to +105°C  
40/100/21 per NFF 61-030
- Flammability rating:  
UL94-V0 (all UTS except the Hi seal) - see page 165  
UL94-HB (UTS Hi seal only) - see page 165  
I2F3 according to NFF 16101 and NFF 16102
- 3 • Salt spray:  
≥500 hours
- 4 • UV resistant:  
No mechanical degradation or important variation of colour after 5 years of exposure in natural environment (equivalence exposure to sun and moisture as per ISO4892)
- 5 • Sealing:
  - UTS Standard: IP68/IP69K (mated)
  - UTS Hi seal: IP68/IP69K (mated and unmated)
  - UTS Discrete wire sealing: IP67/69K (up to IP68 with easy handling backshell)
  - UTS Screw termination contacts: IP68/IP69KNote: IPx8: 10m underwater during 1 week
- Fluid resistance:
  - Gasoil
  - Mineral oil
  - Acid bath
  - Basic bath





## characteristics



### Electrical

- See each layout page

### Material

- Body connector + Backshell:  
Thermoplastic
- Insert:
  - UTS Standard, UTS Discrete wire sealing, UTS Screw termination contacts:  
Thermoplastic
  - UTS Hi seal handsolder & UTS Hi seal with PC tails contacts:  
Elastomer
- Contacts:  
See page 140
- Nut:  
Metal
- Halogen free
- RoHS compliant & conform to the Chinese standard SJ/T1166-2006 (Chinese RoHS equivalent)
- In accordance with:
  - UL 1977:  
Certificat ECBT2  
File number: E169916
  - CSA C22.2 n°182.3:  
Certificat ECBT8  
File number: E169916





UNIT'S Series

# Mechanics

■	<b>Cable assembly</b>			14
■	<b>2 contacts</b>			
	8E2/8D2:	7A	32V	20
	12E2/12D2:	16A	150V	24
■	<b>2 contacts + ground</b>			
	103:	16A	300V	28
	142G1:	40A	300V	32
■	<b>3 contacts</b>			
	8E3/8D3:	7A	32V	36
	8E3A/8E98			
	8D3A/8D98:	7A	50V	40
	8E33/8D3.:	7A	50V	44
	12E3/12D3:	16A	150V	48
■	<b>3 contacts + ground</b>			
	124 - 12E4/12D4:	16A	300V	52
	183G1:	32A	300V	56
■	<b>4 contacts</b>			
	8E4/8D4:	7A	32V	60
	102W2:	25A	150V	64
	104:	13A	150V	68
■	<b>5 contacts</b>			
	14E5/14D5:	16A	150V	72
■	<b>6 contacts</b>			
	103W3:	5A	32V	76
	106 - 10E6/10D6:	7A	32V	80
	10E98/10D98:	7A	50V	84
■	<b>6 contacts + ground</b>			
	147 - 14E7:	16A	300V	88
■	<b>7 contacts</b>			
	10E7/10D7:	7A	50V	92
■	<b>8 contacts</b>			
	128:	10A	80V	96
	12E8/12D8:	6A	32V	100
■	<b>10 contacts</b>			
	1210 - 12E10/12D10:	6A	50V	104
■	<b>12 contacts</b>			
	1412:	10A	63V	108
	14E12/14D12:	4A	50V	112
■	<b>14 contacts</b>			
	12E14/12D14:	5A	32V	116
■	<b>15 contacts</b>			
	14E15/14D15:	4A	50V	120
■	<b>18 contacts</b>			
	14E18/14D18:	5A	50V	124
■	<b>19 contacts</b>			
	1419 - 14E19/14D19:	5A	32V	128
■	<b>23 contacts</b>			
	1823:	9A	63V	132
■	<b>32 contacts</b>			
	1832:	4A	32V	136



## Cable assembly

Souriau provides connectors in various applications for more than 90 years in the most extreme environment. Being conscious about the difficulty to find a quick and a reliable harness manufacturer, we decided years ago to start in house cable assembly production. It allows customers to reduce the number of suppliers, and to take advantage of the "best in class" quality of the Souriau group. Overmoulding is a process that further enhances the sealing properties of the UTS range, especially over many years of use. Overmoulding provides the opportunity to change the cable exit from straight through 90 degrees and avoid any stress on the cable terminated to the connector. Also, as the wires are encapsulated inside the moulding, a barrier is created which prevents from any liquid from entering the equipment through the connector if the cable jacket is breached.



## How to choose the outer jacket material

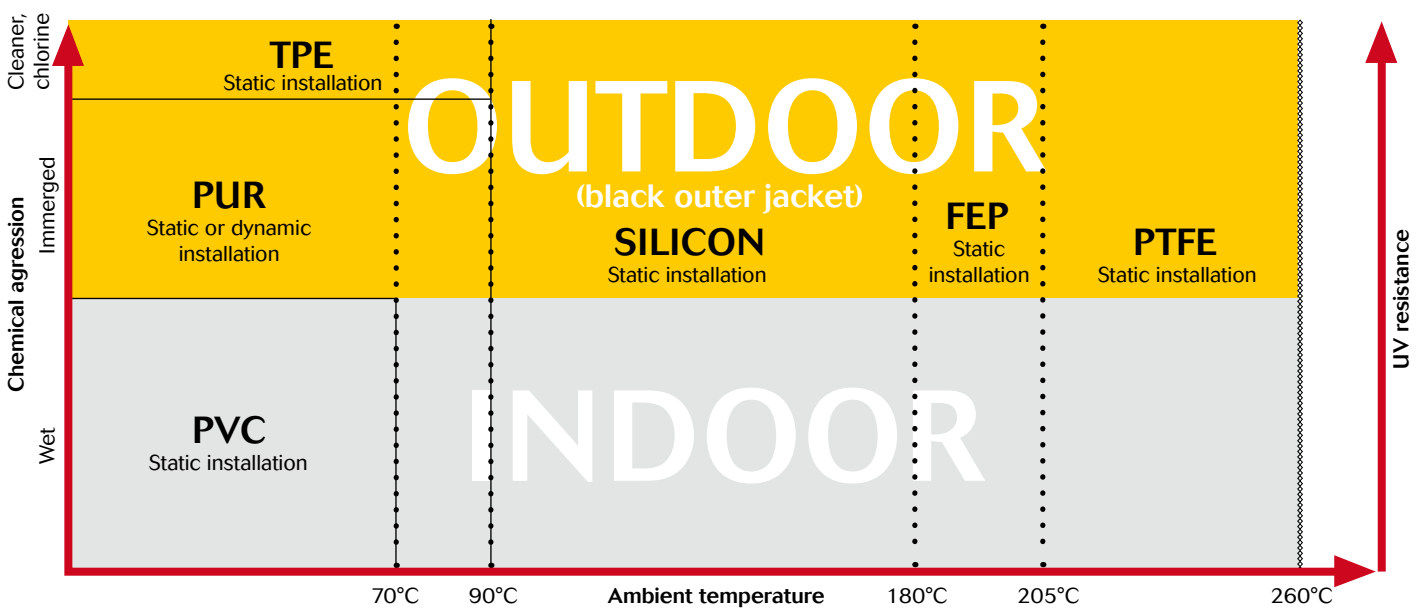



## Overmolding description

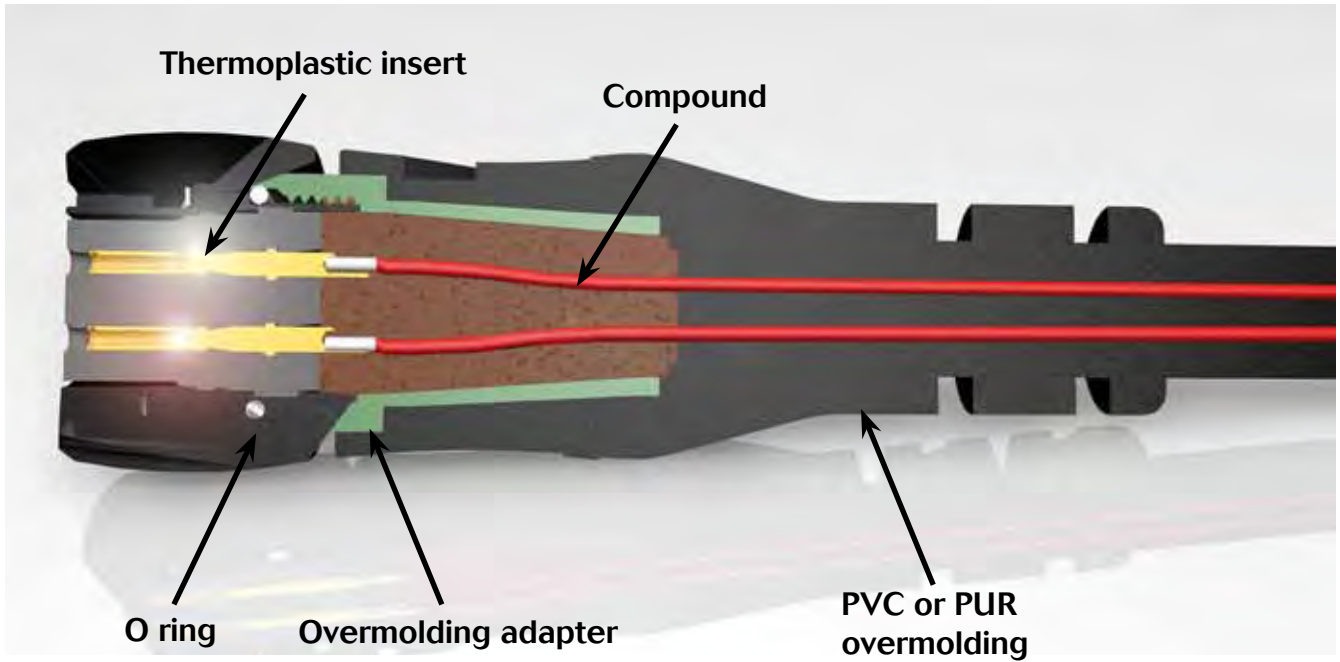

## Discrete connector



## Overmoulded connector







### Harnesses

#### Overmoulded harnesses, straight ending



Connector type	Number of ways	Voltage	Current UL	Current IEC	Harmonised cable part number*	Part number (length: 1 m.)	
						Male	Female
UTS standard	2+PE	600 V	44 A	40 A	HO5 VV - F 3Gg10	HAUTSOV142G1PST100	HAUTSOV142G1SST100
	2+PE	500 V	10 A	16 A	HO5 VV - F 3x1.5	HAUTSOV103PST100	HAUTSOV103SST100
	3+PE	500 V	10 A	16 A	HO5 VV - F 3G1.5	HAUTSOV103PEPST100	HAUTSOV103PESST100
	3+PE	250 V	24 A	32 A	HO5 VV - F 40G0.5	HAUTSOV183G1PST100	HAUTSOV183G1SST100
	3+PE	500 V	10 A	16 A	HO5 VV - F 4G1.5	HAUTSOV124PEPST100	HAUTSOV124PESST100
	4	500 V	10 A	13 A	HO5 VV - F 4x1.5	HAUTSOV104PST100	HAUTSOV104SST100
	3	500 V	10 A	5 A	HO5 VV - F 7G0.5	HAUTSOV103W3PST100	HAUTSOV103W3SST100
	6	250 V	5 A	7 A	HO5 VV - F 7x0.5	HAUTSOV106PST100	HAUTSOV106SST100
	6+PE	500 V	10 A	16 A	HO5 VV - F 7G1.5	HAUTSOV147PEPST100	HAUTSOV147PESST100
	8	500 V	10 A	10 A	HO5 VV - F 8x1.5	HAUTSOV128PST100	HAUTSOV128SST100
	10	250 V	5 A	6 A	HO5 VV - F 10G0.5	HAUTSOV1210PST100	HAUTSOV1210SST100
	12	500 V	10 A	10 A	HO5 VV - F 12x1.5	HAUTSOV1412PST100	HAUTSOV1412SST100
	19	250 V	5 A	5 A	HO5 VV - F 21G0.5	HAUTSOV1419PST100	HAUTSOV1419SST100
	23	500 V	10 A	9 A	HO5 VV - F 25G1.5	HAUTSOV1823PST100	HAUTSOV1823SST100
	32	250 V	5 A	4 A	HO5 VV - F 40G0.5	HAUTSOV1832PST100	HAUTSOV1832SST100
UTS Hi seal	2	250 V	7 A	7 A	HO5 VV - F 2x0.5	HAUTSOV8E2PST100	HAUTSOV8E2SST100
	2	650 V	13 A	16 A	HO5 VV - F 2x1.5	HAUTSOV12E2PST100	HAUTSOV12E2SST100
	3	250 V	7 A	7 A	HO5 VV - F 3x0.5	HAUTSOV8E3PST100	HAUTSOV8E3SST100
	3	250 V	7 A	7 A	HO5 VV - F 3x0.5	HAUTSOV8E3APST100	HAUTSOV8E3ASST100
	3	250 V	7 A	7 A	HO5 VV - F 3x0.5	HAUTSOV8E33PST100	HAUTSOV8E33SST100
	3	650 V	13 A	16 A	HO5 VV - F 3x1.5	HAUTSOV12E3PST100	HAUTSOV12E3SST100
	4	250 V	7 A	7 A	HO5 VV - F 4x0.5	HAUTSOV8E4PST100	HAUTSOV8E4SST100
	5	650 V	12 A	16 A	HO5 VV - F 4G1.5	HAUTSOV14E5PST100	HAUTSOV14E5SST100
	6	250 V	5 A	7 A	HO5 VV - F 7x0.5	HAUTSOV10E6PST100	HAUTSOV10E6SST100
	6	250 V	6 A	7 A	HO5 VV - F 7x0.5	HAUTSOV10E98PST100	HAUTSOV10E98SST100
	6+PE	500 V	10 A	16 A	HO5 VV - F 7G1.5	HAUTSOV14E7PEPST100	HAUTSOV14E7PESST100
	7	250 V	6 A	7 A	HO5 VV - F 7x0.5	HAUTSOV10E7PST100	HAUTSOV10E7SST100
	8	250 V	5 A	6 A	HO5 VV - F 10G0.5	HAUTSOV12E8PST100	HAUTSOV12E8SST100
	10	250 V	5 A	6 A	HO5 VV - F 10G0.5	HAUTSOV12E10PST100	HAUTSOV12E10SST100
	12	250 V	5 A	4 A	HO5 VV - F 12G0.5	HAUTSOV14E12PST100	HAUTSOV14E12SST100
	14	250 V	5 A	5 A	HO5 VV - F 14G0.5	HAUTSOV12E14PST100	HAUTSOV12E14SST100
	15	650 V	12 A	4 A	HO5 VV - F 18G0.5	HAUTSOV14E15PST100	HAUTSOV14E15SST100
	18	250 V	4 A	4 A	HO5 VV - F 18G0.5	HAUTSOV14E18PST100	HAUTSOV14E18SST100
	19	250 V	4 A	5 A	HO5 VV - F 40G0.5	HAUTSOV14E19PST100	HAUTSOV14E19SST100

\* see page 18

3 m & 5 m version available on demand

Eg: 3m HAUTSOV. . . 300

5m HAUTSOV. . . 500

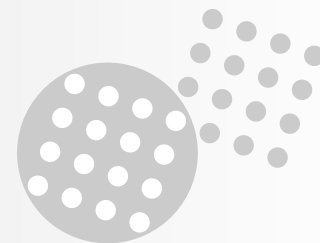

### Harnesses

#### Overmoulded harnesses, right angle ending



Connector type	Number of ways	Voltage	Current UL	Current IEC	Harmonised cable part number*	Part number (length: 1 m.)	
						Male	Female
UTS standard	2+PE	600 V	44 A	40 A	HO5 VV - F 3Gg10	HAUTSOV142G1PRA100	HAUTSOV142G1SRA100
	2+PE	500 V	10 A	16 A	HO5 VV - F 3x1.5	HAUTSOV103PRA100	HAUTSOV103SRA100
	3+PE	500 V	10 A	16 A	HO5 VV - F 3G1.5	HAUTSOV183G1PRA100	HAUTSOV183G1SRA100
	3+PE	250 V	24 A	32 A	HO5 VV - F 40G0.5	HAUTSOV183G1PRA100	HAUTSOV183G1SRA100
	3+PE	500 V	10 A	16 A	HO5 VV - F 4G1.5	HAUTSOV124PEPRA100	HAUTSOV124PESRA100
	4	500 V	10 A	13 A	HO5 VV - F 4x1.5	HAUTSOV104PRA100	HAUTSOV104SRA100
	3	500 V	10 A	5 A	HO5 VV - F 7G0.5	HAUTSOV103W3PRA100	HAUTSOV103W3SRA100
	6	250 V	5 A	7 A	HO5 VV - F 7x0.5	HAUTSOV106PRA100	HAUTSOV106SRA100
	6+PE	500 V	10 A	16 A	HO5 VV - F 7G1.5	HAUTSOV147PEPRA100	HAUTSOV147PESRA100
	8	500 V	10 A	10 A	HO5 VV - F 8x1.5	HAUTSOV128PRA100	HAUTSOV128SRA100
	10	250 V	5 A	6 A	HO5 VV - F 10G0.5	HAUTSOV1210PRA100	HAUTSOV1210SRA100
	12	500 V	10 A	10 A	HO5 VV - F 12x1.5	HAUTSOV1412PRA100	HAUTSOV1412SRA100
	19	250 V	5 A	5 A	HO5 VV - F 21G0.5	HAUTSOV1419PRA100	HAUTSOV1419SRA100
	23	500 V	10 A	9 A	HO5 VV - F 25G1.5	HAUTSOV1823PRA100	HAUTSOV1823SRA100
	32	250 V	5 A	4 A	HO5 VV - F 40G0.5	HAUTSOV1832PRA100	HAUTSOV1832SRA100
UTS Hi seal	2	250 V	7 A	7 A	HO5 VV - F 2x0.5	HAUTSOV8E2PRA100	HAUTSOV8E2SRA100
	2	650 V	13 A	16 A	HO5 VV - F 2x1.5	HAUTSOV12E2PRA100	HAUTSOV12E2SRA100
	3	250 V	7 A	7 A	HO5 VV - F 3x0.5	HAUTSOV8E3PRA100	HAUTSOV8E3SRA100
	3	250 V	7 A	7 A	HO5 VV - F 3x0.5	HAUTSOV8E3APRA100	HAUTSOV8E3ASRA100
	3	250 V	7 A	7 A	HO5 VV - F 3x0.5	HAUTSOV8E33PRA100	HAUTSOV8E33SRA100
	3	650 V	13 A	16 A	HO5 VV - F 3x1.5	HAUTSOV12E3PRA100	HAUTSOV12E3SRA100
	4	250 V	7 A	7 A	HO5 VV - F 4x0.5	HAUTSOV8E4PRA100	HAUTSOV8E4SRA100
	5	650 V	12 A	16 A	HO5 VV - F 4G1.5	HAUTSOV14E5PRA100	HAUTSOV14E5SRA100
	6	250 V	5 A	7 A	HO5 VV - F 7x0.5	HAUTSOV10E6PRA100	HAUTSOV10E6SRA100
	6	250 V	6 A	7 A	HO5 VV - F 7x0.5	HAUTSOV10E98PRA100	HAUTSOV10E98SRA100
	6+PE	500 V	10 A	16 A	HO5 VV - F 7G1.5	HAUTSOV14E7PEPRA100	HAUTSOV14E7PESRA100
	7	250 V	6 A	7 A	HO5 VV - F 7x0.5	HAUTSOV10E7PRA100	HAUTSOV10E7SRA100
	8	250 V	5 A	6 A	HO5 VV - F 10G0.5	HAUTSOV12E8PRA100	HAUTSOV12E8SRA100
	10	250 V	5 A	6 A	HO5 VV - F 10G0.5	HAUTSOV12E10PRA100	HAUTSOV12E10SRA100
	12	250 V	5 A	4 A	HO5 VV - F 12G0.5	HAUTSOV14E12PRA100	HAUTSOV14E12SRA100
	14	250 V	5 A	5 A	HO5 VV - F 14G0.5	HAUTSOV12E14PRA100	HAUTSOV12E14SRA100
	15	650 V	12 A	4 A	HO5 VV - F 18G0.5	HAUTSOV14E15PRA100	HAUTSOV14E15SRA100
	18	250 V	4 A	4 A	HO5 VV - F 18G0.5	HAUTSOV14E18PRA100	HAUTSOV14E18SRA100
	19	250 V	4 A	5 A	HO5 VV - F 40G0.5	HAUTSOV14E19PRA100	HAUTSOV14E19SRA100

\* see page 18

3 m & 5 m version available on demand

Eg: 3m HAUTSOV. . . 300

5m HAUTSOV. . . 500



### Cable information

<b>Range of temperature:</b>	Occasional flexing: -5°C up to +70°C Fixed installation: -40°C up to +80°C
<b>Rated voltage:</b>	U0/U: 300/500 V
<b>Wire section :</b>	Arrangement with #16 contact: wire section 1.5 mm <sup>2</sup> Arrangement with #20 contact: wire section 0.5 mm <sup>2</sup>
<b>Harmonized reference:</b>	H05 VVF XX

### Standardization of European cable - DIN VDE 0281/DIN VDE 0282/DIN VDE 0292

#### Harmonized wire coding system

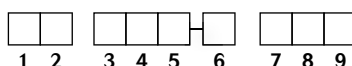

1. Basic type	2. Working voltage	3. Insulating	4. Sheath-cladding material	5. Special features	6. Conductor types	7. Number of conductors	8. Protective conductor	9. Conductor cross-sectional
H: Harmonized Type	03: 300/300 V.	V: PVC	V: PVC	H: Ribbon cable, separable	U: Single wire		X: Without protective conductor	Area specified in mm <sup>2</sup>
A: National Type	05: 300/500 V.	R: Rubber	R: Rubber	H2: Ribbon cable non-separable	R: Multi-wire		G: With protective conductor	
	07: 450/750 V.	S: Silicone Rubber	N: Cloroprene Rubber		K: Fine wire (permanently installed)			
			J: Glass-filament braiding		F: Fine wire (flexible)			
			T: Textile braiding		H: Super fine wire			
					Y: Tinsel strand			

Example: Harmonized type, 300/500V, PVC insulating, PVC sheath-cladding, Fine wire, 3x1.5 cross-sectional: H05VVF3x1.5



### Standardization of American cable

#### Nomenclature Key

<b>S:</b>	Service Grade (also means extra hard service when not followed by J, V, or P)
<b>J:</b>	Hard Service
<b>V:</b>	Vacuum cleaner cord (also light duty cable)
<b>P:</b>	Parallel cord (also known as zip cord) – Always light duty
<b>E:</b>	Thermoplastic Elastomer (UL/NEC designation ONLY)
<b>O:</b>	Oil Resistant*
<b>T:</b>	Thermoplastic
<b>W:</b>	Outdoor-includes sunlight resistant jacket and wet location rated conductors (formerly "W-A")
<b>H:</b>	Heater cable
<b>VW-1:</b>	Flame retardant
<b>FT2:</b>	Flame retardant

#### Definitions of Cable Types

<b>SVT:</b>	Thermoplastic insulated vacuum cleaner cord, with or without 3rd conductor for grounding purposes; 300V. (PVC)
<b>SJT:</b>	Junior hard service, thermoplastic insulated conductors and jacket. 300V. (PVC)
<b>SJTW:</b>	Same as SJT except outdoor rated. (PVC)
<b>SJTO:</b>	Same as SJT but oil resistant outer jacket. (PVC)
<b>SJTOW:</b>	Same as SJTO except outdoor rated. (PVC)
<b>ST:</b>	Hard service cord with all thermoplastic construction, 600V. (PVC)
<b>STW:</b>	Same as ST except outdoor rated. (PVC)
<b>STO:</b>	Same as ST but with oil resistant outer jacket. (PVC)
<b>STOW:</b>	Same as STO except outdoor rated. (PVC)

# UTS Series

## 8E2/8D2

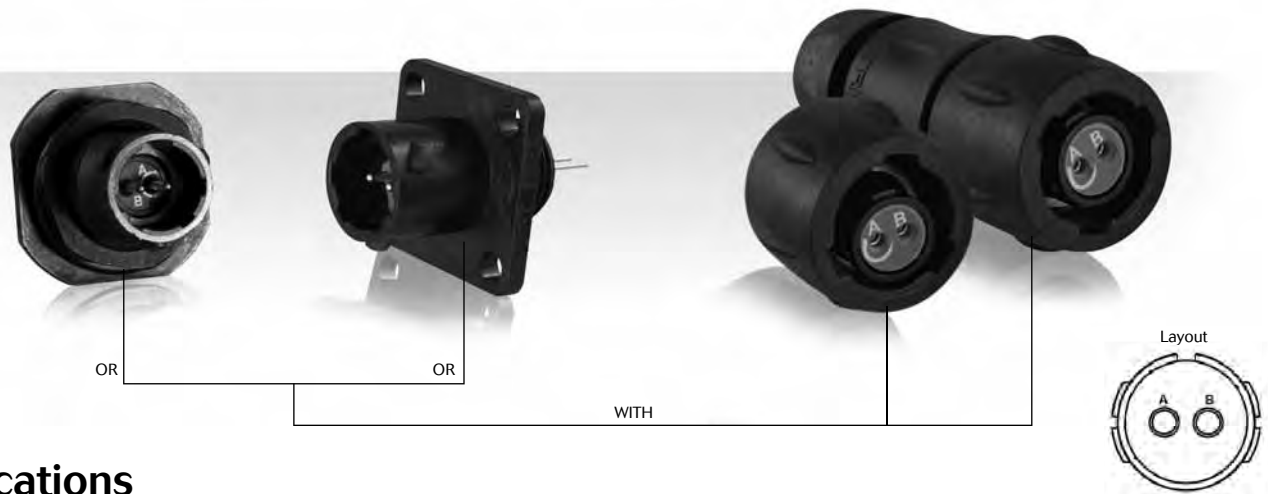

### Specifications

Contact type	Connector type	Backshell	Part number	
			Male insert	Female insert
Hand solder electrical contacts loaded	Square flange receptacle	Without (Fig.1)	UTS08E2P	UTS08E2S
	Plug	Without (Fig.6)	UTS68E2P	UTS68E2S
		Cable gland (Fig.7)	UTS6JC8E2P	UTS6JC8E2S
	Jam nut receptacle	Without (Fig.3)	UTS78E2P	UTS78E2S
PCB contacts loaded	Square flange receptacle	Without (Fig.2)	UTS08D2P	UTS08D2S
	Jam nut receptacle with stand off and with hold down clips	Without (Fig.5)	UTS78D2P32	UTS78D2S32
	Jam nut receptacle with stand off and without hold down clip	Without (Fig.4)	UTS78D2P	UTS78D2S

Sealed unmatred



### Dimensions

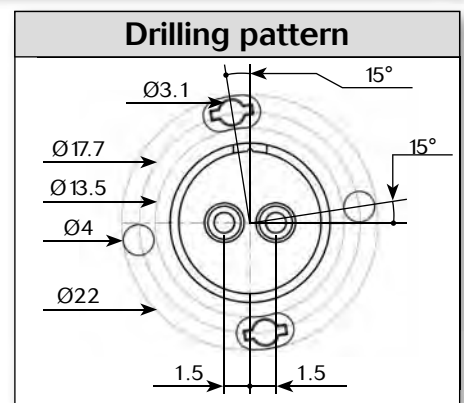
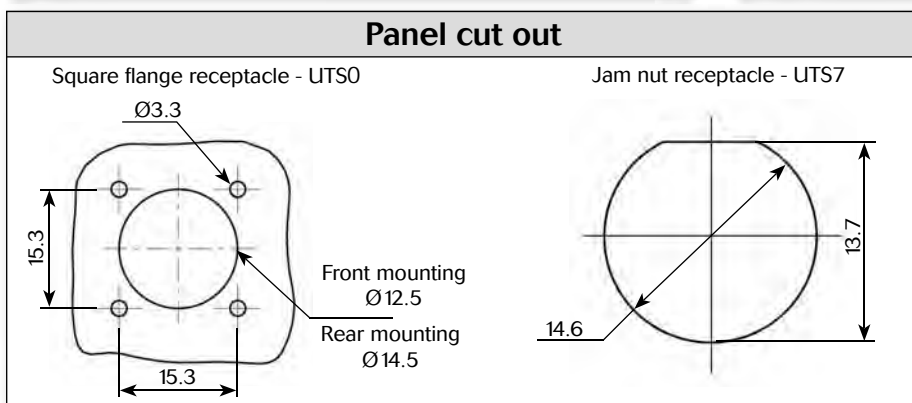
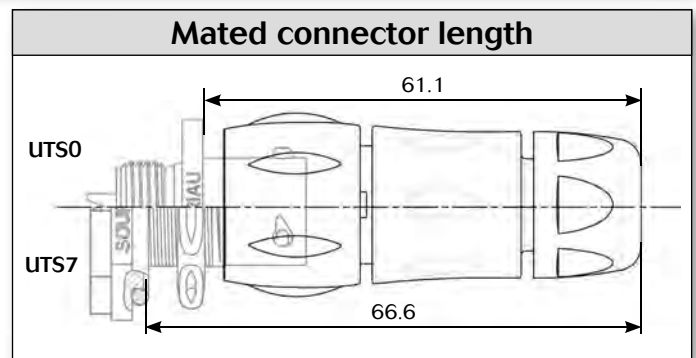
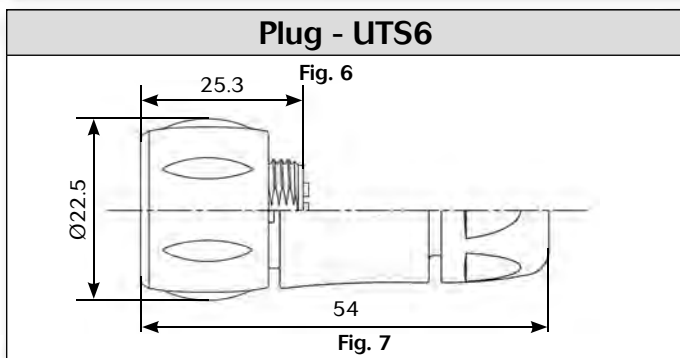
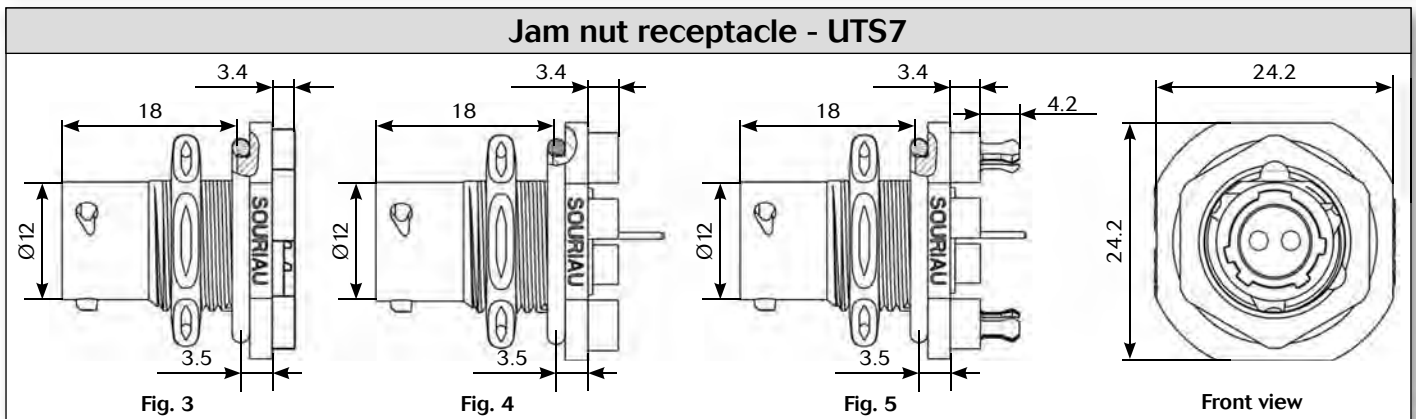
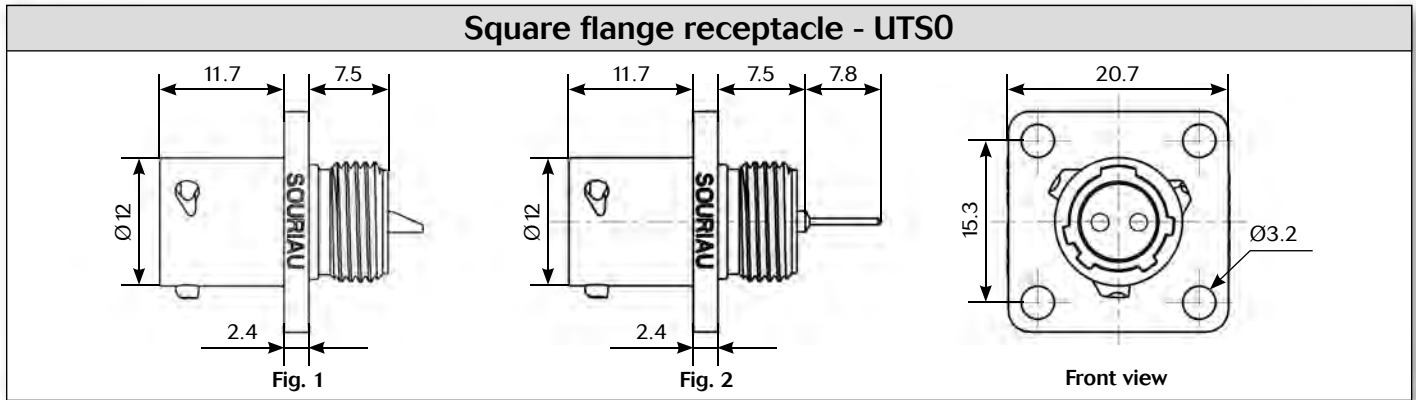

Note: all dimensions are in mm



### Accessories

#### Jam nut sealing caps

Part number	Part number
UTS8DCG	UTS8DCGR

Metal terminal

#### Square flange sealing cap

Part number
UTS8DCGE

Metal terminal

#### Plug protective cap

Part number
UTS68C

IP40

#### Plastic protective cap

Part numbers	
Receptacle cap	Plug cap
85005585A	85005594

#### Gasket

Part numbers / neoprene
UTFD11B

#### Electrical characteristics

**UL**  
7A 250V UL94 HB

**CSA**  
7A 250V UL94 HB

**IEC**  
7A 32V 1.5kV 3

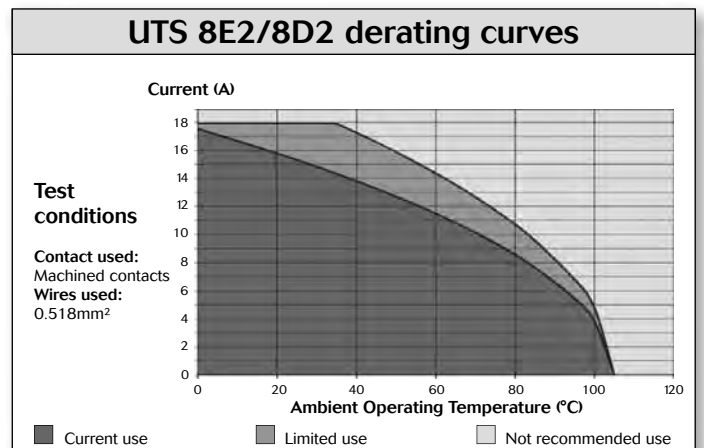

# UTS Series

8E2/8D2





# UTS Series

## 12E2/12D2

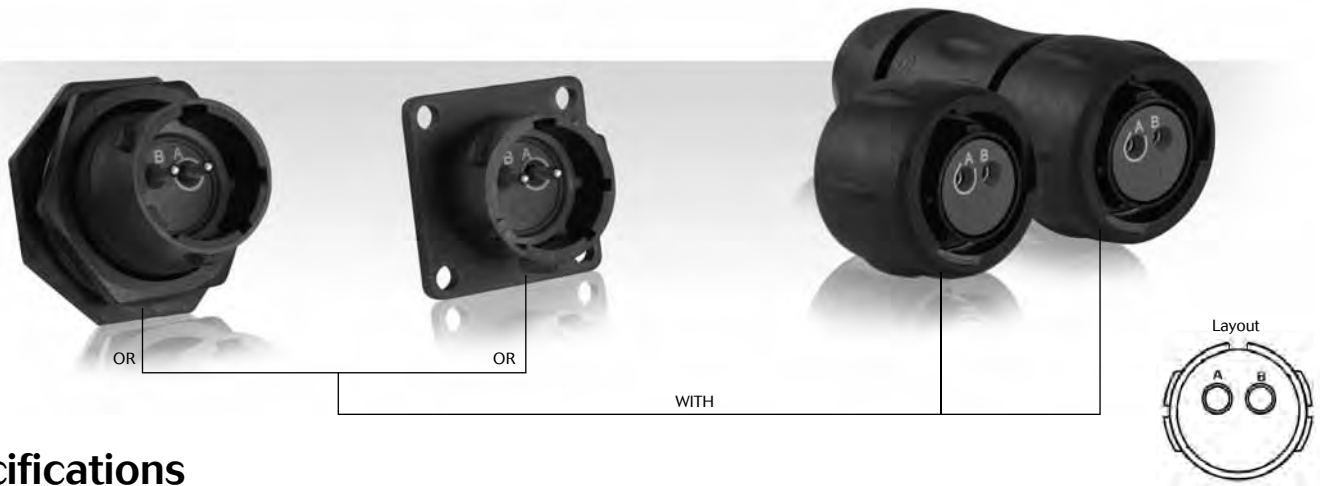

## Specifications

Contact type	Connector type	Backshell	Part number	
			Male insert	Female insert
Hand solder electrical contacts loaded	Square flange receptacle	Without (Fig.1)	UTS012E2P	UTS012E2S
	Plug	Without (Fig.6)	UTS612E2P	UTS612E2S
		Cable gland (Fig.7)	UTS6JC12E2P	UTS6JC12E2S
	Jam nut receptacle	Without (Fig.3)	UTS712E2P	UTS712E2S
PCB contacts loaded	Square flange receptacle	Without (Fig.2)	UTS012D2P	UTS012D2S
	Jam nut receptacle with stand off and with hold down clips	Without (Fig.5)	UTS712D2P32	UTS712D2S32
	Jam nut receptacle with stand off and without hold down clip	Without (Fig.4)	UTS712D2P	UTS712D2S

Sealed unmatred 



### Dimensions

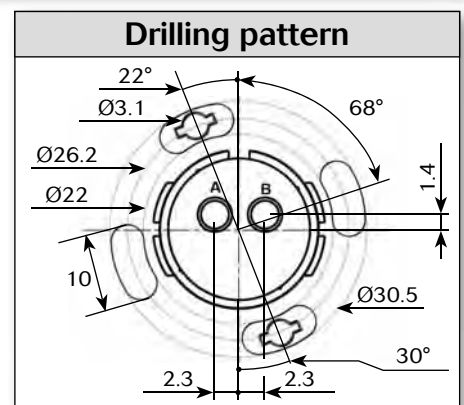
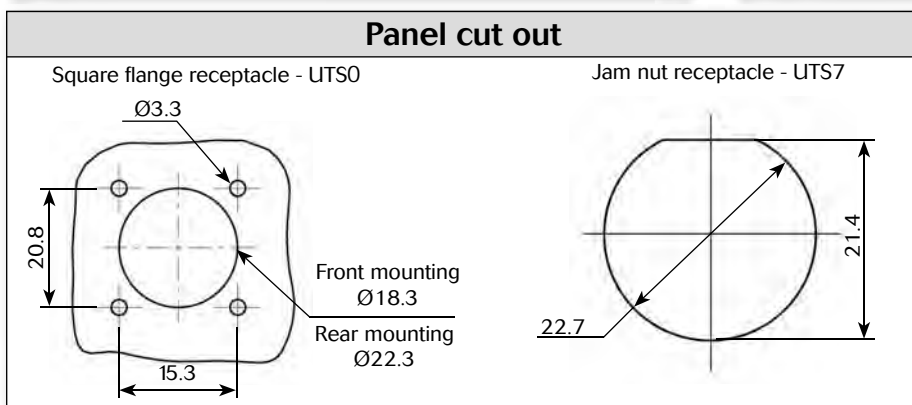
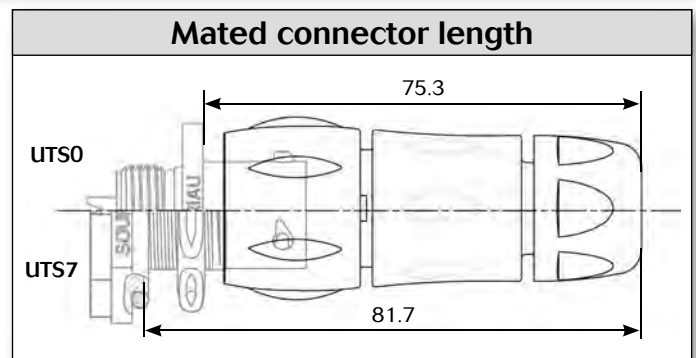
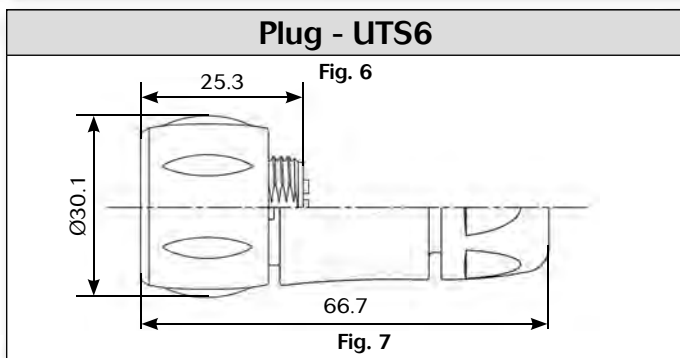
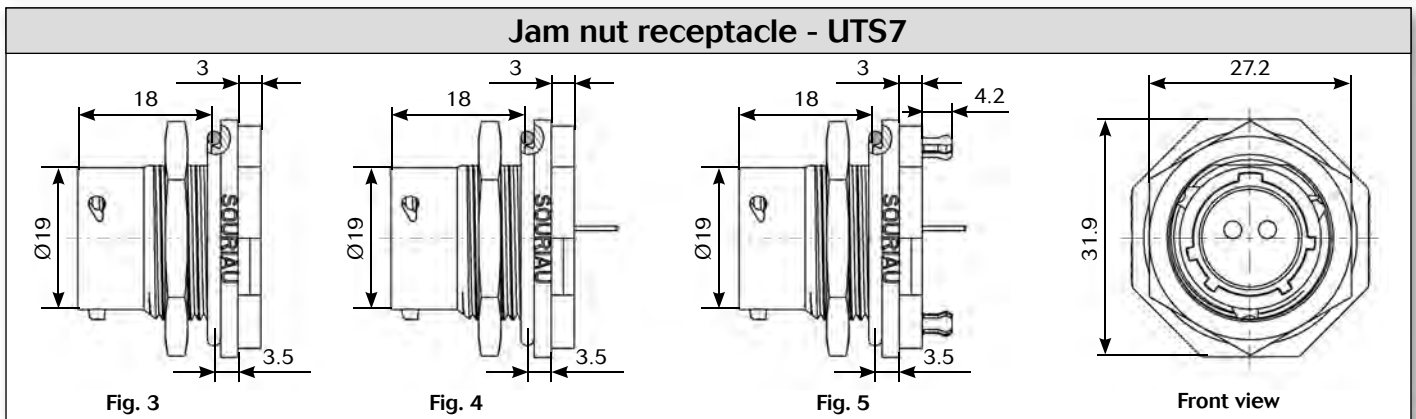
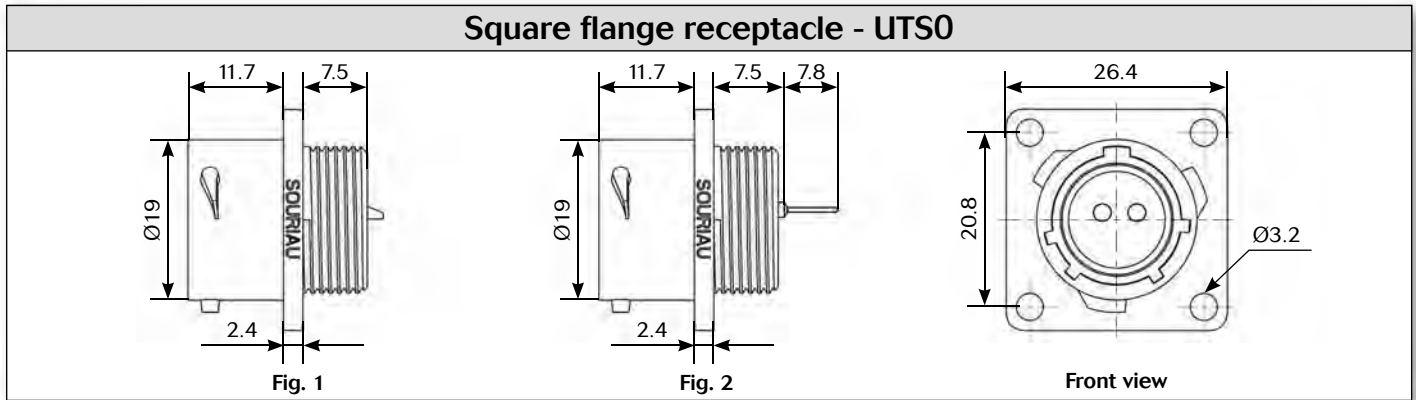

Note: all dimensions are in mm



### Accessories

#### Jam nut sealing caps

Metal terminal

Part number
UTS12DCG

Part number
UTS12DCGR

#### Plug sealing cap

Part number
UTS612DCG

#### Square flange sealing cap

Metal terminal

Part number
UTS12DCGE

#### Plastic protective cap

Part numbers	
Receptacle cap	Plug cap
85005587A	85005596

#### Gasket

Part numbers / neoprene
UTFD13B

#### Color coding rings

G for Green  
Y for Yellow  
R for Red

Part numbers	
Receptacles	Plugs
UTS712CCR	UTS612CCR
UTS712CCRY	UTS612CCRY
UTS712CCRG	UTS612CCRG

\* Add G for Green, Y for Yellow, R for Red

#### Electrical characteristics

**UL**  
13A 650V UL94 HB

**CSA**  
13A 650V UL94 HB

**IEC**  
16A 150V 2.5kV 3

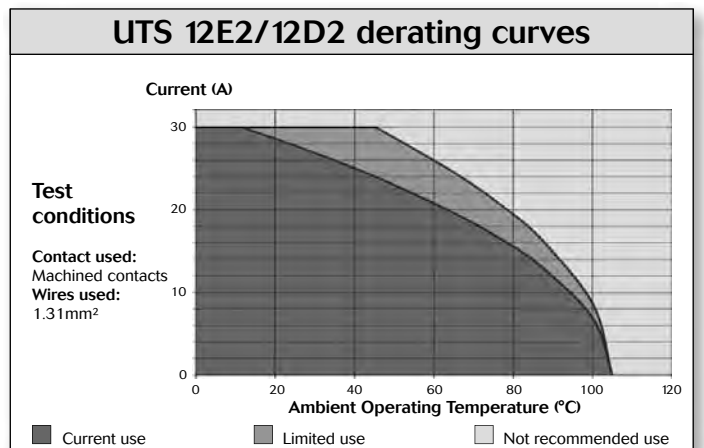

# UTS Series

12E2/12D2





## Specifications

Contact type	Connector type	Backshell	Part number	
			Male insert	Female insert
Crimp contacts supply separately see page 31	Free hanging receptacle	Cable gland (Fig.1)	UTS1JC103P	UTS1JC103S
		Without (Fig.2)	UTS6103P	UTS6103S
	Plug	Cable gland (Fig.3)	UTS6JC103P	UTS6JC103S
PCB contacts supply separately see page 31	Jam nut receptacle	Without (Fig.4)	UTS7103P	UTS7103S



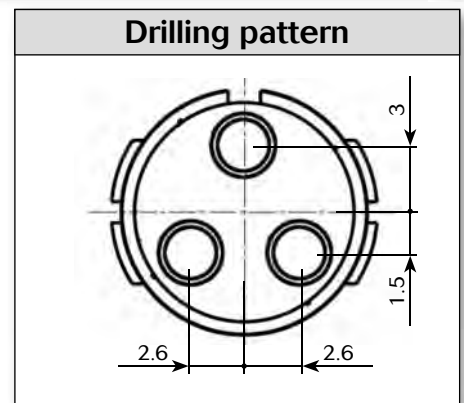
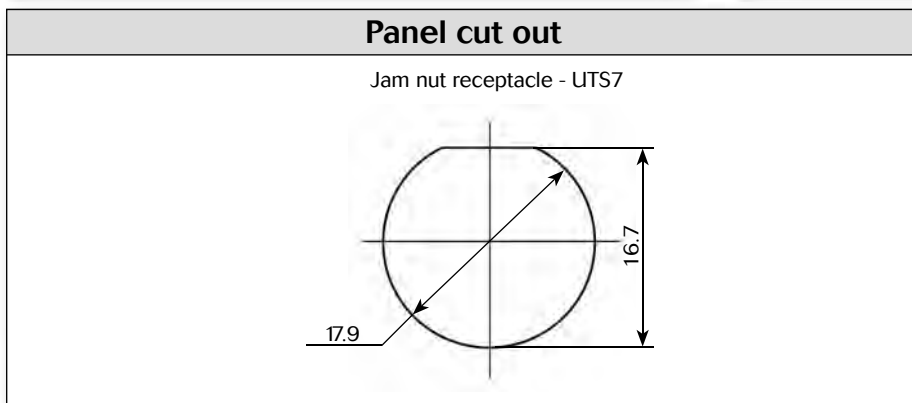
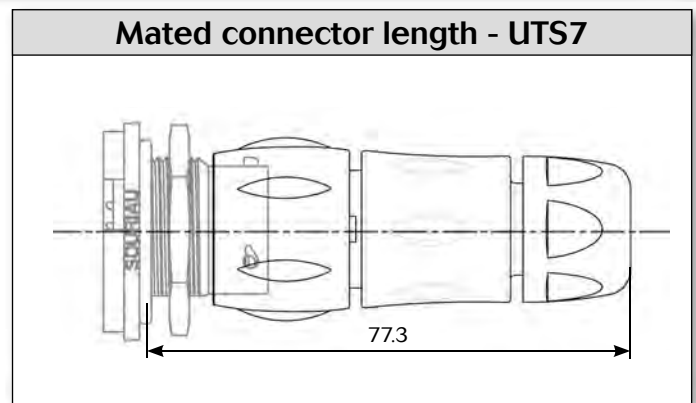
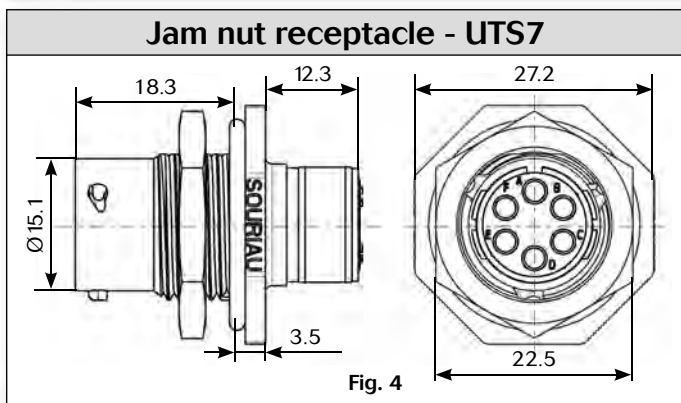
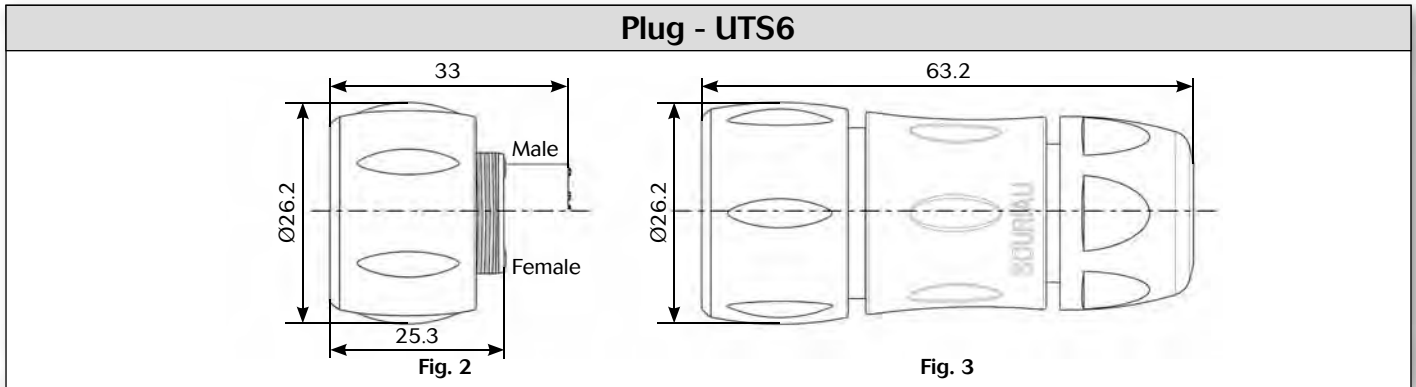
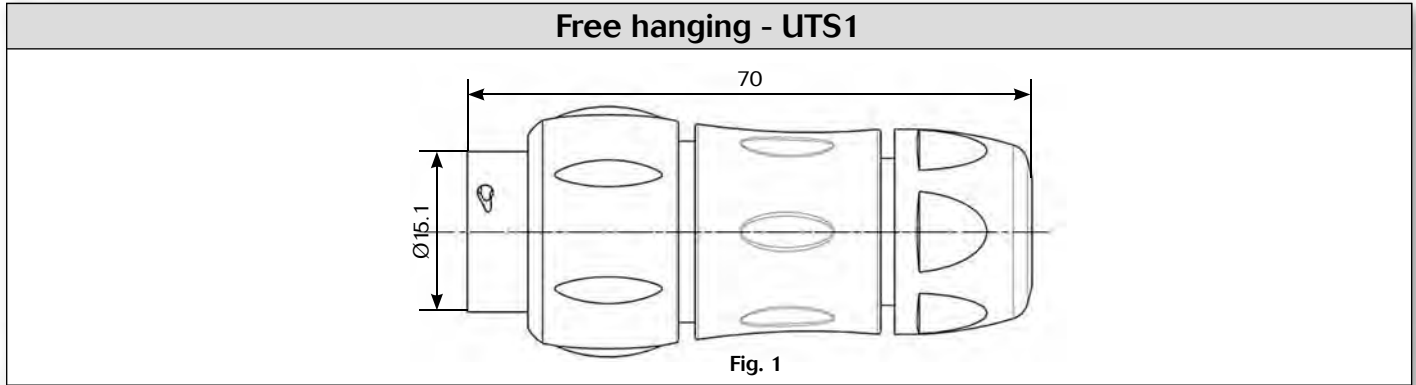

### Dimensions



Note: all dimensions are in mm



### Accessories and tooling

Jam nut sealing caps	
	
Part number	Part number
UTS10DCG	UTS10DCGR

Metal terminal

Handle

Part number
SHANGLES

Tool kit

Part number
TOOLKIT

Plug sealing cap



Part number
UTS610DCG

Crimp tooling			
			
Contacts	Contact size	Part number of head	
RM/RC 28M1K <sup>(1)</sup>	Standard contacts #16 Ø 1.6mm	S16RCM20	
RM/RC 24M9K <sup>(1)</sup>		S16RCM20	
RM/RC 20M13K <sup>(1)</sup>		S16RCM20	
RM/RC 20M12K <sup>(1)</sup>		S16RCM20	
RM/RC 16M23K <sup>(1)</sup>		S16RCM16	
RM/RC 14M50K <sup>(1)</sup>		S16RCM1450	
RM/RC 14M30K <sup>(1)</sup>		S16RCM14	
SM/SC 24ML1TK6 <sup>(1)</sup>		S16SCM20	
SM/SC 20ML1TK6 <sup>(1)</sup>		S16SCM20	
SM/SC 16ML1TK6 <sup>(1)</sup>		S16SCML1	
SM/SC 14ML1TK6 <sup>(1)</sup>		S16SCML1	
SM/SC 16ML11TK6 <sup>(1)</sup>		S16SCML11	
RMDXK10D28K		Coaxial contacts	M10S-1J
RCDXK1D28K			M10S-1J
RM/RC DX60xxD28K	M10S-1J		
RM/RC DXK10D28 + york090	M10S-1J		
RM/RC DX60xxD28		M10S-1J	

(1): example of plating, for other plating see UTS catalog page 143

Plastic protective cap	
	
Part numbers	
Receptacle cap	Plug cap
85005586A	85005595

Gasket

Part numbers / neoprene
UTFD12B

Color coding rings	
G for Green	
Y for Yellow	
R for Red	
Part numbers	
Receptacles	Plugs
UTS710CCRR	UTS610CCRR
UTS710CCRY	UTS610CCRY
UTS710CCRG	UTS610CCRG

\* Add G for Green, Y for Yellow, R for Red



### Contacts

#16	Contact type	AWG	Part number		Max wire Ø	Max insulator Ø
			Male	Female		
Crimp	Machined	30-28	RM28M1K <sup>(1)</sup>	RC28M1K <sup>(1)</sup>	0.55	1.1
		26-24	RM24M9K <sup>(1)</sup>	RC24M9K <sup>(1)</sup>	0.8	1.6
		22-20	RM20M13K <sup>(1)</sup>	RC20M13K <sup>(1)</sup>	1.18	1.8
		22-20	RM20M12K <sup>(1)</sup>	RC20M12K <sup>(1)</sup>	1.18	2.2
		20-16	RM16M23K <sup>(1)</sup>	RC16M23K <sup>(1)</sup>	1.8	3.2
		16-14	RM14M50K <sup>(1)</sup>	RC14M50K <sup>(1)</sup>	2.05	3.2
		16-14	RM14M30K <sup>(1)</sup>	RC14M30K <sup>(1)</sup>	2.28	3.2
	Stamped & formed reeled contacts	26-24	SM24M1TK6 <sup>(1)(2)</sup>	SC24M1TK6 <sup>(1)(2)</sup>	0.89-1.28	-
		22-20	SM20M1TK6 <sup>(1)(2)</sup>	SC20M1TK6 <sup>(1)(2)</sup>	1.17-2.08	-
		18-16	SM16M1TK6 <sup>(1)(2)</sup>	SC16M1TK6 <sup>(1)(2)</sup>	3.0	-
18-16		SM16M11TK6 <sup>(1)(2)</sup>	SC16M11TK6 <sup>(1)(2)</sup>	2.0-3.0	-	
14		SM14M1TK6 <sup>(1)(2)</sup>	SC14M1TK6 <sup>(1)(2)</sup>	3.2	-	
PCB	Machined <sup>(3)</sup>	-	RM20M12E8K <sup>(1)</sup>	RC20M12E84K <sup>(1)</sup>	-	-
Coaxial	Cable Multipiece	-	RMDXK10D28	RCDXK1D28	-	-
	Cable Monocrimp	-	RMDX60xxD28	RCDX60xxD28	-	-
	Twisted pair Multipiece	-	RMDXK10D28 + york090	RCDXK1D28 + york090	-	-
	Twisted pair Monocrimp	-	RMDX60xxD28	RCDX60xxD28	-	-
Fiber optic	POF contacts Plastic optical fibre	-	RMPOF1000	RCPOF1000B	-	-

(1): Example of plating, for other plating see page 143  
 (2): Loose piece contact available if putting L. Example: SM20ML1-TK6  
 (3): For dimensions see page 148

#### Electrical characteristics

**UL**  
10A 500V UL94 V-0

**CSA**  
7A 500V UL94 V-0

**IEC**  
16A 300V 4kV 3  
Temperature elevation: 50°C

#### UTS 103 derating curves

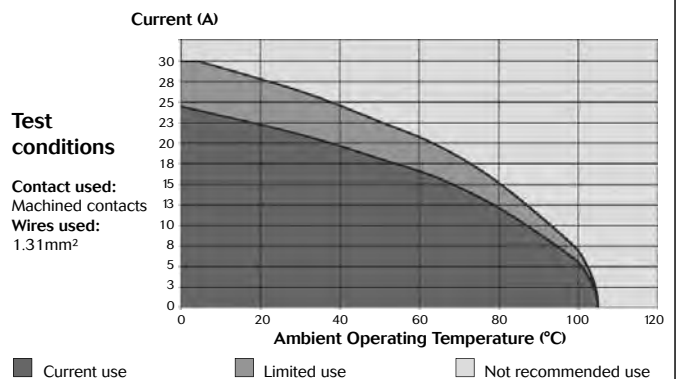



# UTS Series 142G1

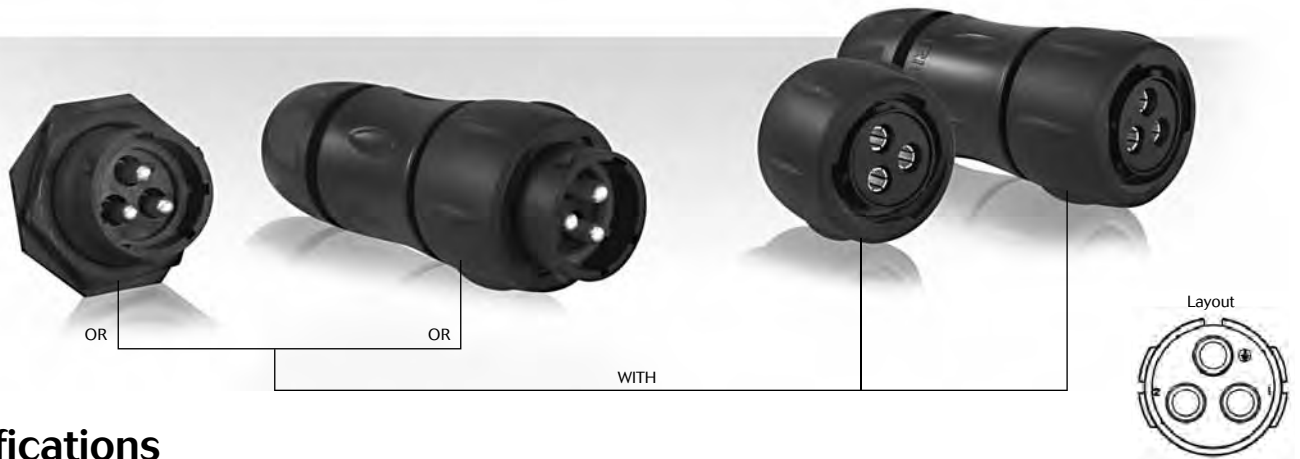

## Specifications

Contact type	Connector type	Backshell	Part number	
			Male insert	Female insert
Crimp contacts supply separately see page 35	Free hanging receptacle	Cable gland (Fig.1)	UTS1JC142G1P	UTS1JC142G1S
	Plug	Without (Fig.3)	UTS6142G1P	UTS6142G1S
		Cable gland (Fig.4)	UTS6JC142G1P	UTS6JC142G1S
	Jam nut receptacle	Without (Fig.2)	UTS7142G1P	UTS7142G1S
NPT threaded receptacle	Without (Fig.5)		UTS7142G1SNPT	



### Dimensions

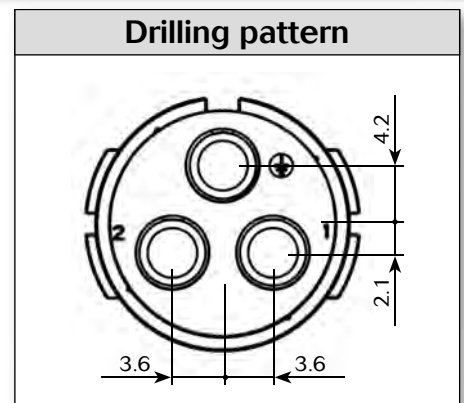
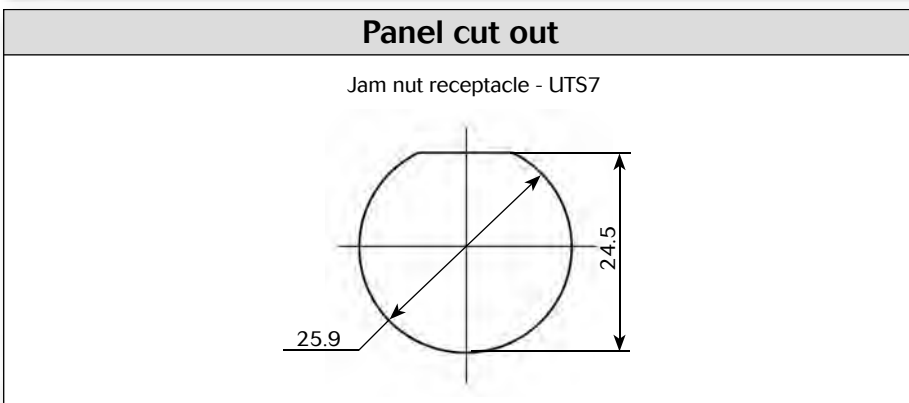
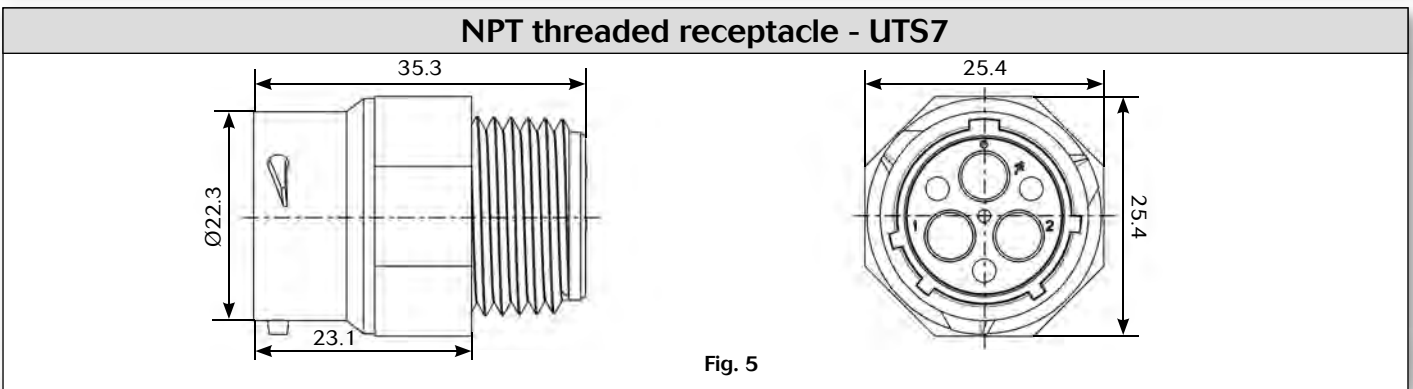
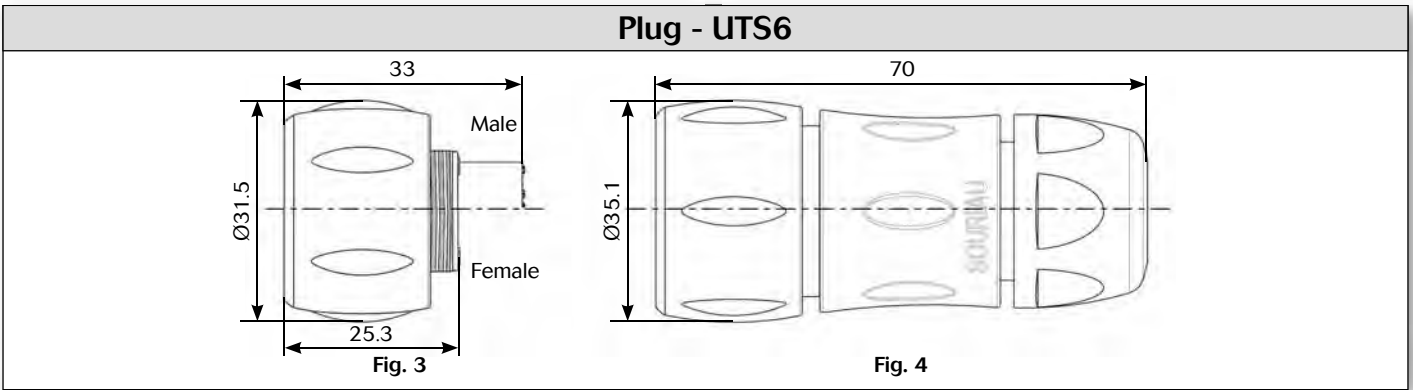
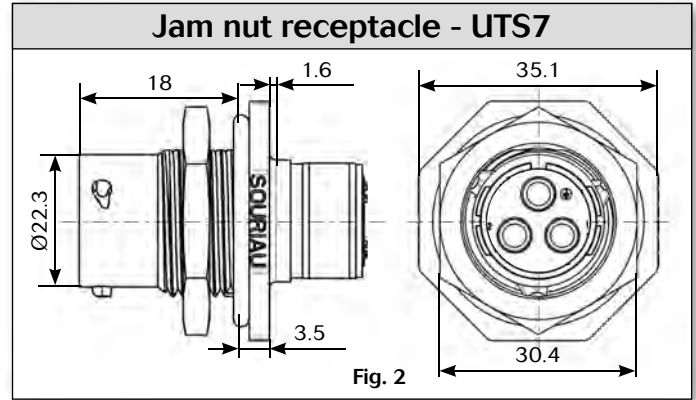
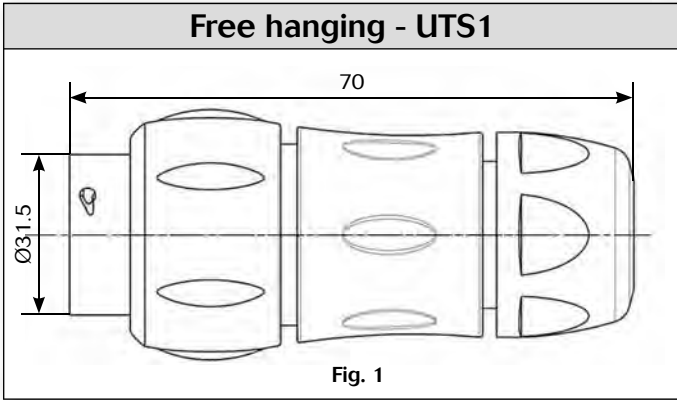

Note: all dimensions are in mm



### Accessories and tooling

Jam nut sealing caps	
	
Part number	Part number
UTS14DCG	UTS14DCGR

Metal terminal

Hand tool

Part number
M317

Plug sealing cap

Part number
UTS614DCG

Positioner + locator setting



Part number
VGE10078A

Plastic protective cap	
	
Part numbers	
Receptacle cap	Plug cap
85005588A	85005597

Gasket

Part numbers / neoprene
UTFD14B

Extraction tool

Part number
51060210936

Color coding rings	
G for Green	
Y for Yellow	
R for Red	
Part numbers	
Receptacles	Plugs
UTS714CCRR	UTS614CCRR
UTS714CCRY	UTS614CCRY
UTS714CCRG	UTS614CCRG

\* Add G for Green, Y for Yellow, R for Red



2 + ground  
40A/300V  
per IEC 61984

### Contacts

#8	Contact type	AWG	Part number		Max wire Ø	Max insulator Ø
			Male	Female		
Crimp	Machined	16	82913601A <sup>(1)</sup>	82913600A <sup>(1)</sup>	-	6.5
		14	82913603A <sup>(1)</sup>	82913602A <sup>(1)</sup>	-	
		12	82913605A <sup>(1)</sup>	82913604A <sup>(1)</sup>	-	
		10	82913607A <sup>(1)</sup>	82913606A <sup>(1)</sup>	-	
		8	82913609A <sup>(1)</sup>	82913608A <sup>(1)</sup>	-	

(1): Example of plating, for other plating see page 143

Electrical characteristics
<p><b>UL</b> 44A 600V UL94 V-0</p> <p><b>CSA</b> 30A 600V UL94 V-0</p> <p><b>IEC</b> 40A 300V 4kV 3</p>

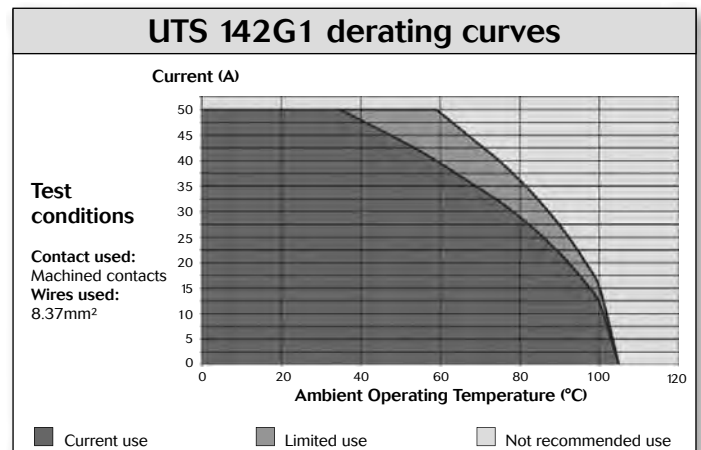

# UTS Series

## 8E3/8D3

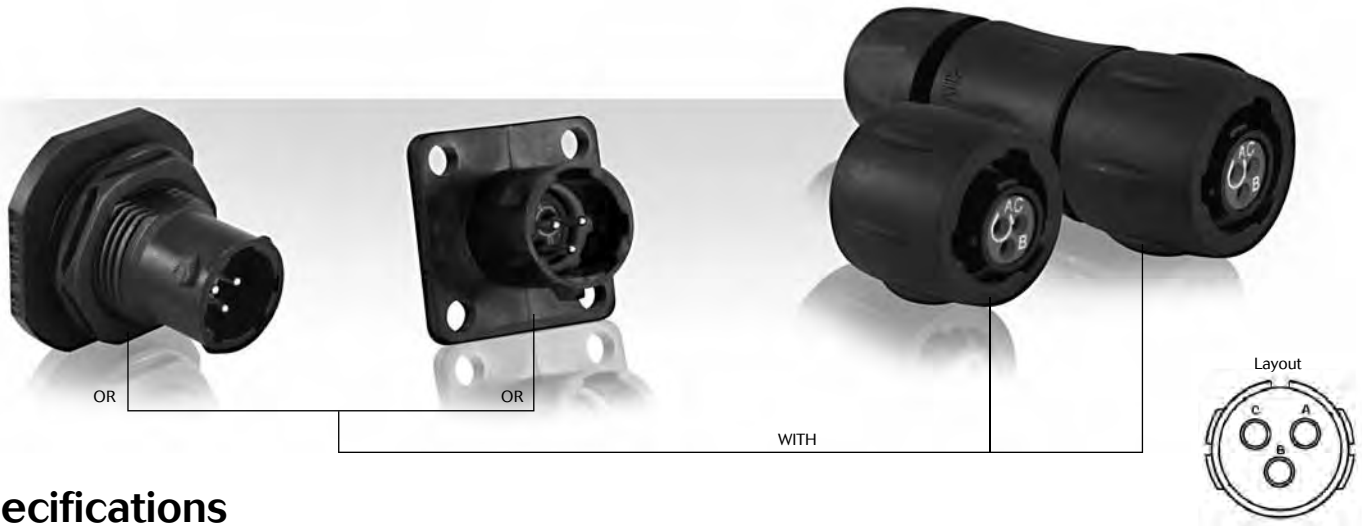

## Specifications

Contact type	Connector type	Backshell	Part number	
			Male insert	Female insert
Hand solder electrical contacts loaded	Square flange receptacle	Without (Fig.1)	UTS08E3P	UTS08E3S
	Plug	Without (Fig.6)	UTS68E3P	UTS68E3S
		Cable gland (Fig.7)	UTS6JC8E3P	UTS6JC8E3S
	Jam nut receptacle	Without (Fig.3)	UTS78E3P	UTS78E3S
PCB contacts loaded	Square flange receptacle	Without (Fig.2)	UTS08D3P	UTS08D3S
	Jam nut receptacle with stand off and with hold down clips	Without (Fig.5)	UTS78D3P32	UTS78D3S32
	Jam nut receptacle with stand off and without hold down clip	Without (Fig.4)	UTS78D3P	UTS78D3S

Sealed unmated



### Dimensions

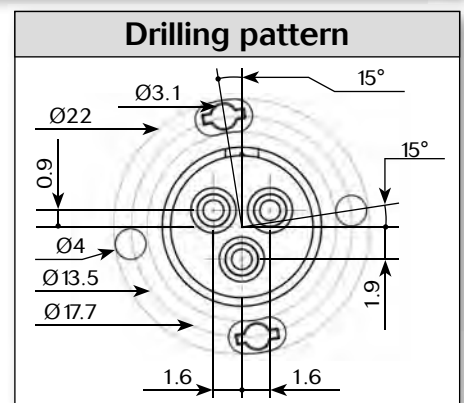
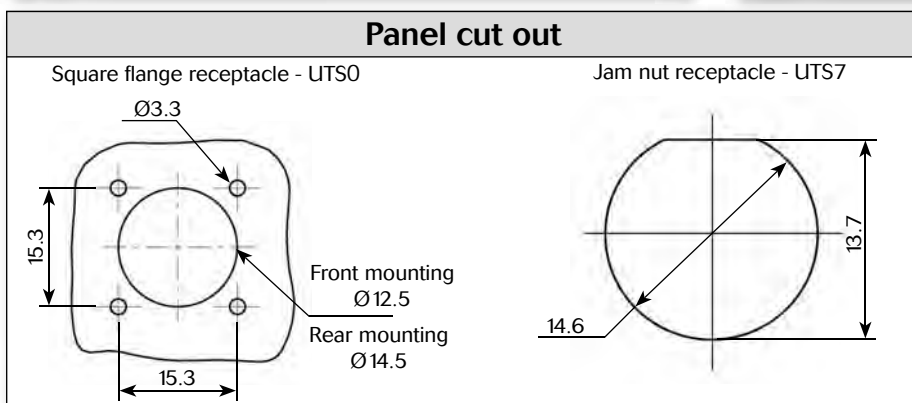
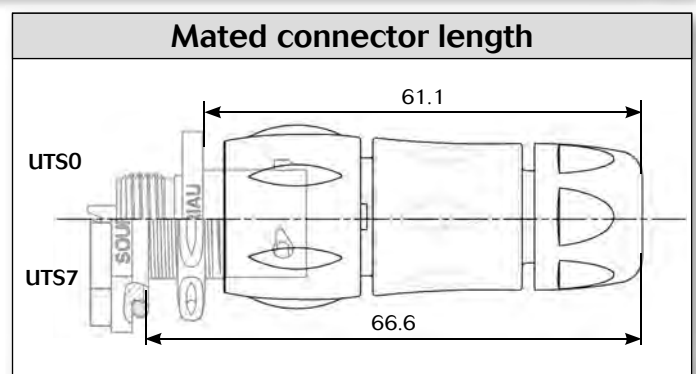
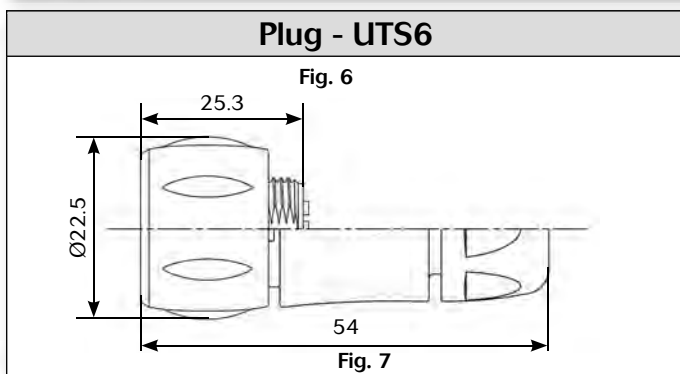
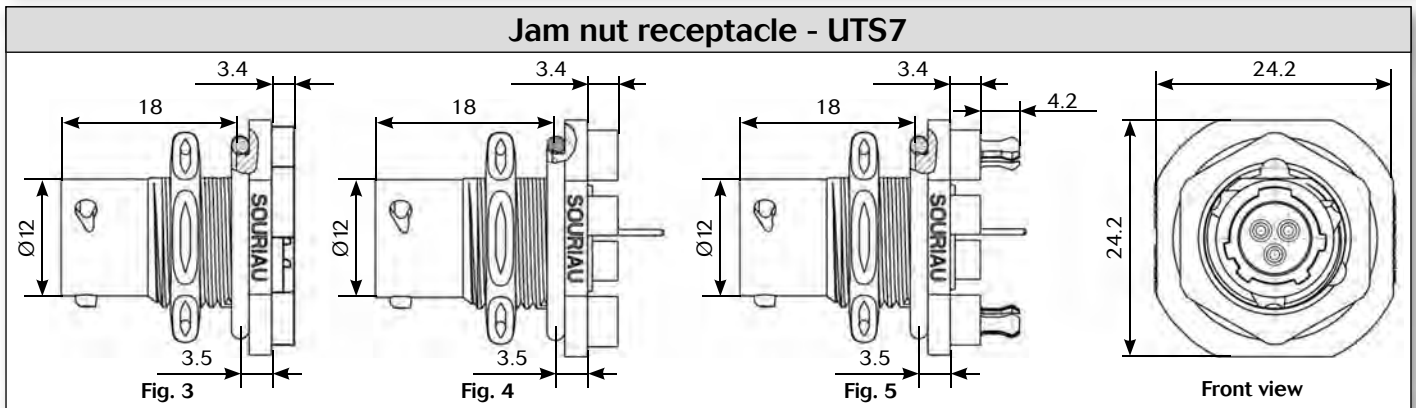
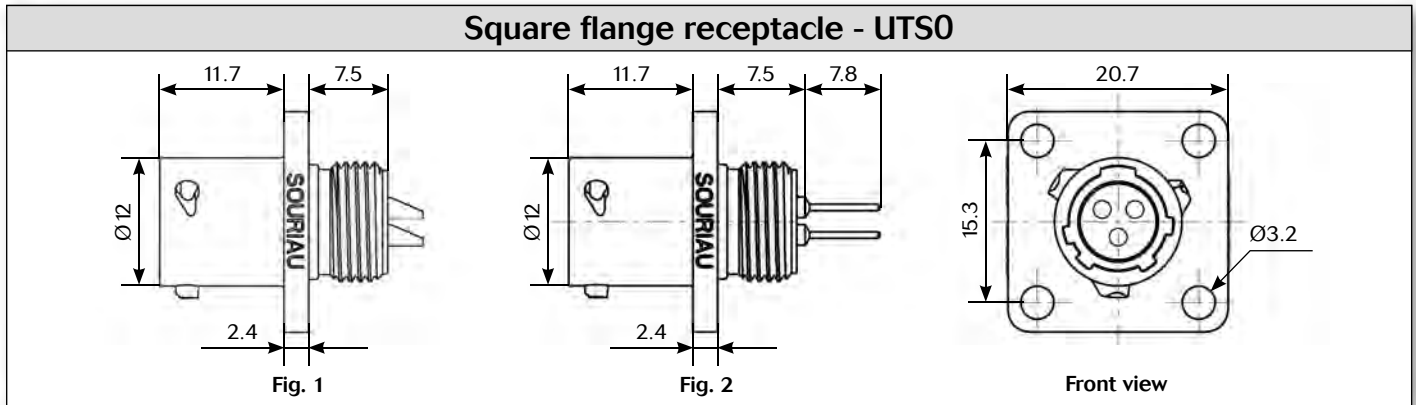

Note: all dimensions are in mm



### Accessories

#### Jam nut sealing caps

Part number	Part number
UTS8DCG	UTS8DCGR

Metal terminal

#### Square flange sealing cap

Part number
UTS8DCGE

Metal terminal

#### Plug protective cap

Part number
UTS68C

IP40

#### Plastic protective cap

Part numbers	
Receptacle cap	Plug cap
85005585A	85005594

#### Gasket

Part numbers / neoprene
UTFD11B

#### Electrical characteristics

**UL**  
7A 250V UL94 HB

**CSA**  
7A 250V UL94 HB

**IEC**  
7A 32V 1.5kV 3

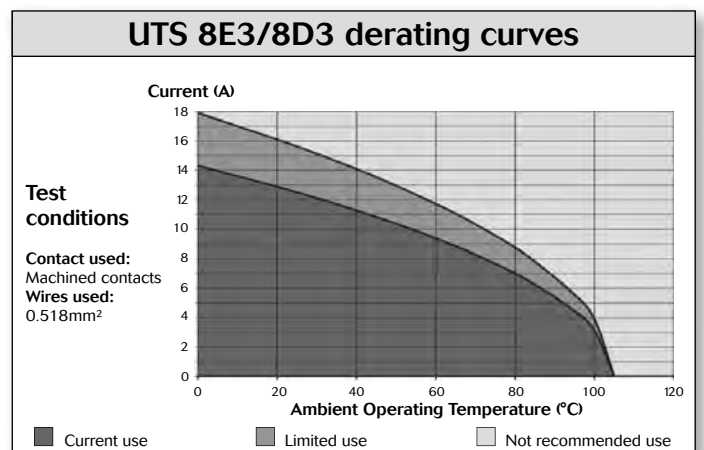

# UTS Series

8E3/8D3





# UTS Series

## 8E3A/8E98 - 8D3A/8D98

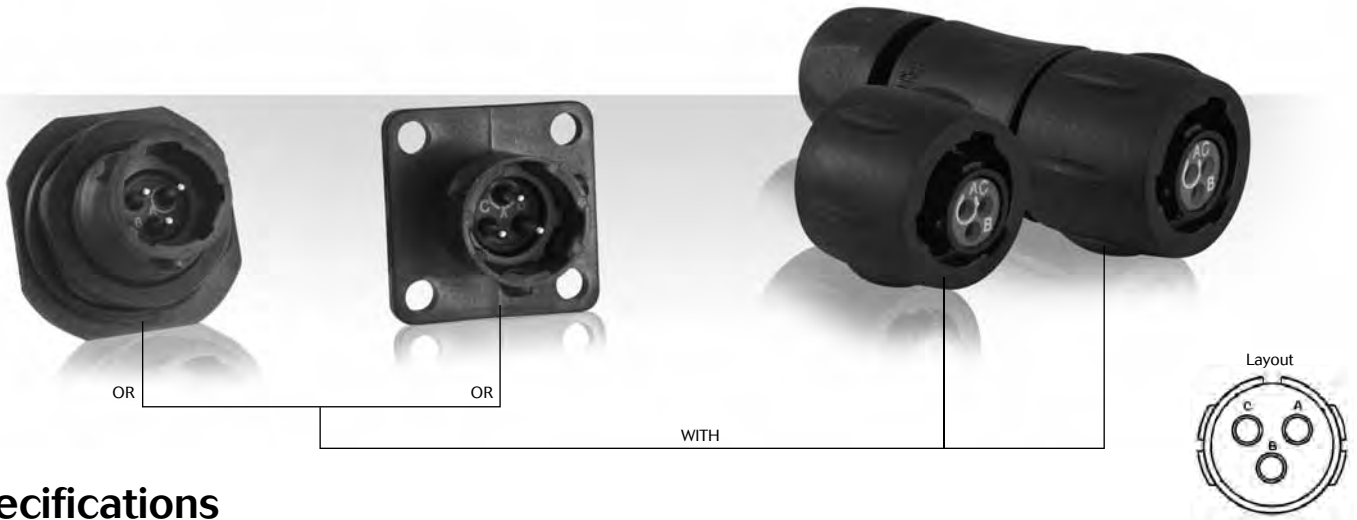

## Specifications

Contact type	Connector type	Backshell	Part number	
			Male insert	Female insert
Hand solder electrical contacts loaded	Square flange receptacle	Without (Fig.1)	UTS08E3AP	UTS08E3AS
			UTS08E98P	UTS08E98S
			UTS68E3AP	UTS68E3AS
	Plug	Without (Fig.6)	UTS68E98P	UTS68E98S
			UTS6JC8E3AP	UTS6JC8E3AS
			UTS6JC8E98P	UTS6JC8E98S
	Jam nut receptacle	Without (Fig.3)	UTS78E3AP	UTS78E3AS
			UTS78E98P	UTS78E98S
	PCB contacts loaded	Square flange receptacle	Without (Fig.2)	UTS08D3AP
UTS08D98P				UTS08D98S
Jam nut receptacle with stand off and with hold down clips		Without (Fig.5)	UTS78D3AP32	UTS78D3AS32
			UTS78D98P32	UTS78D98S32
Jam nut receptacle with stand off and without hold down clip		Without (Fig.4)	UTS78D3AP	UTS78D3AS
			UTS78D98P	UTS78D98S

Sealed unmatad



### Dimensions

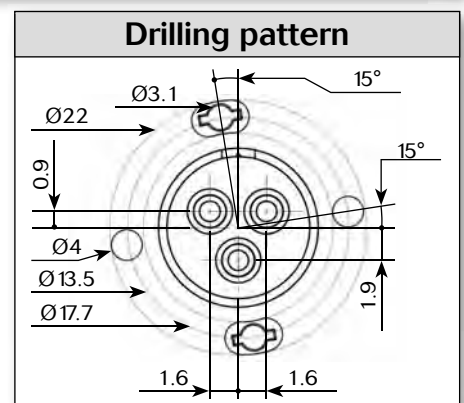
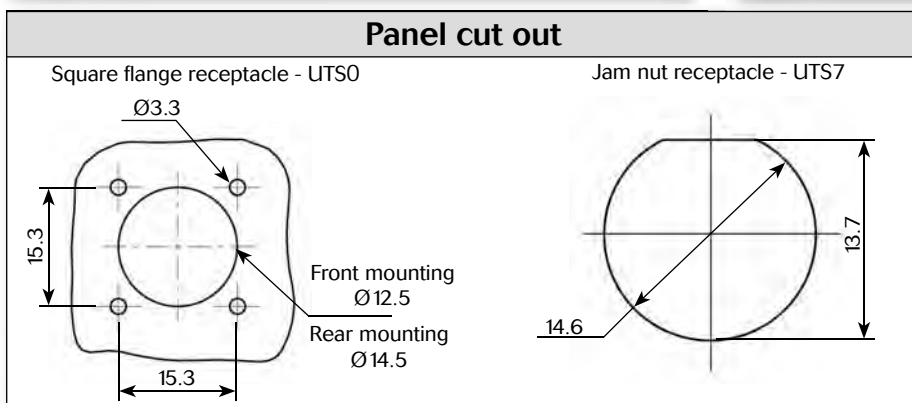
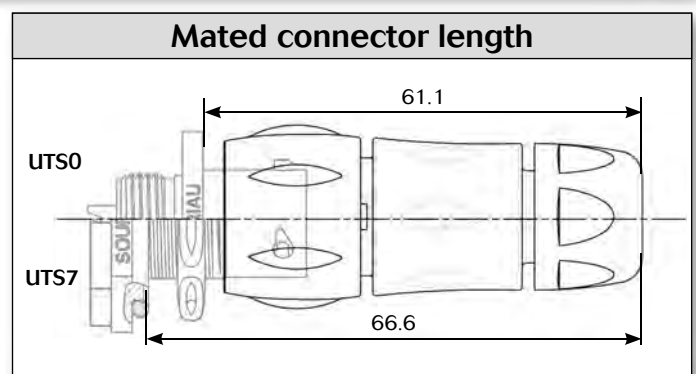
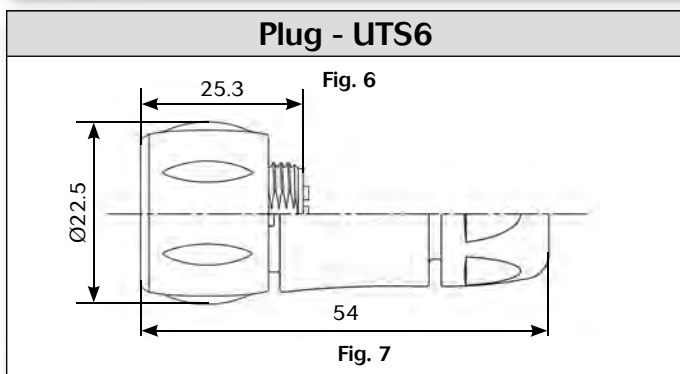
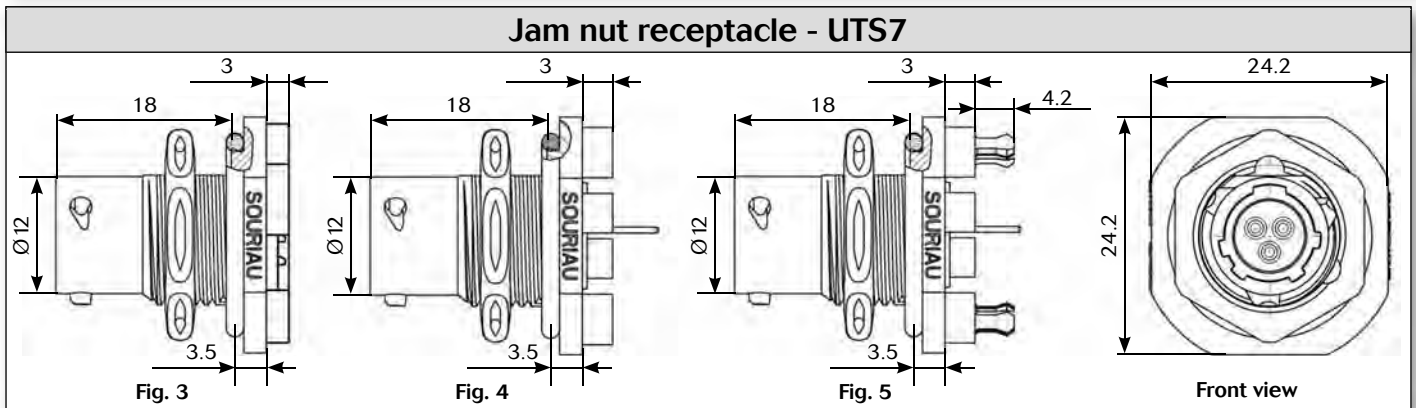
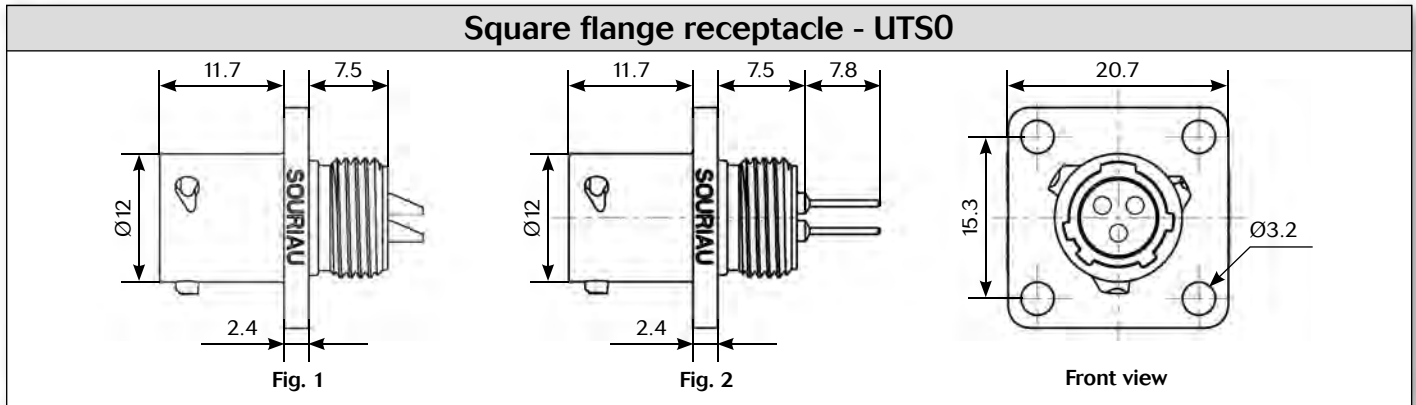

Note: all dimensions are in mm

# UTS Series

## 8E3A/8E98 - 8D3A/8D98



### Accessories

**Jam nut sealing caps**

Metal terminal

Part number
UTS8DCG

Part number
UTS8DCGR

**Square flange sealing cap**

Metal terminal

Part number
UTS8DCGE

**Plug protective cap**

IP40

Part number
UTS68C

**Plastic protective cap**

Part numbers	
Receptacle cap	Plug cap
85005585A	85005594

**Gasket**

Part numbers / neoprene
UTFD11B

**Electrical characteristics**

**UL**  
7A 250V UL94 HB

**CSA**  
7A 250V UL94 HB

**IEC**  
7A 50V 1.5kV 3

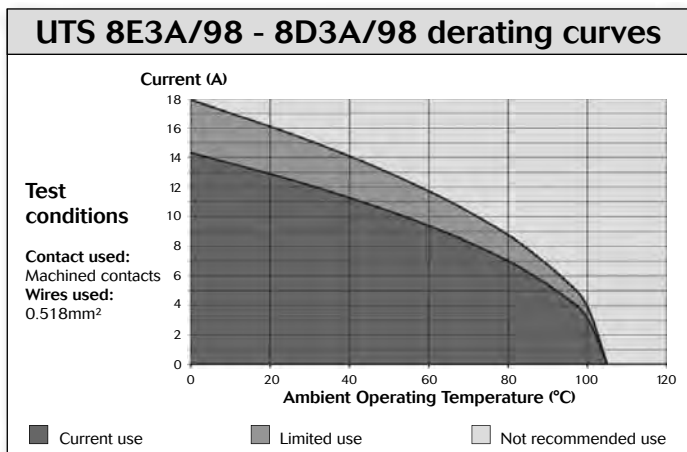

# UTS Series

8E3A/8E98 - 8D3A/8D98



# UTS Series

## 8E33/8D33

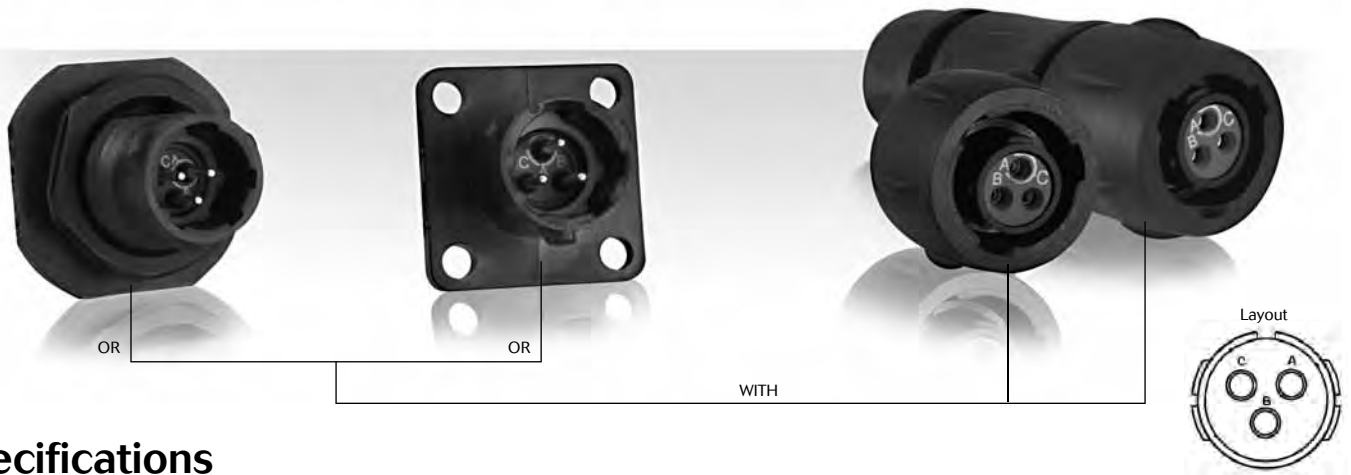

### Specifications

Contact type	Connector type	Backshell	Part number	
			Male insert	Female insert
Hand solder electrical contacts loaded	Square flange receptacle	Without (Fig.1)	UTS08E33P	UTS08E33S
	Plug	Without (Fig.6)	UTS68E33P	UTS68E33S
		Cable gland (Fig.7)	UTS6JC8E33P	UTS6JC8E33S
	Jam nut receptacle	Without (Fig.3)	UTS78E33P	UTS78E33S
PCB contacts loaded	Square flange receptacle	Without (Fig.2)	UTS08D33P	UTS08D33S
	Jam nut receptacle with stand off and with hold down clips	Without (Fig.5)	UTS78D33P32	UTS78D33S32
	Jam nut receptacle with stand off and without hold down clip	Without (Fig.4)	UTS78D33P	UTS78D33S

Sealed unmated



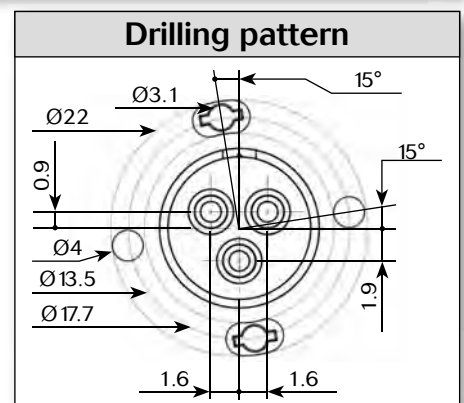
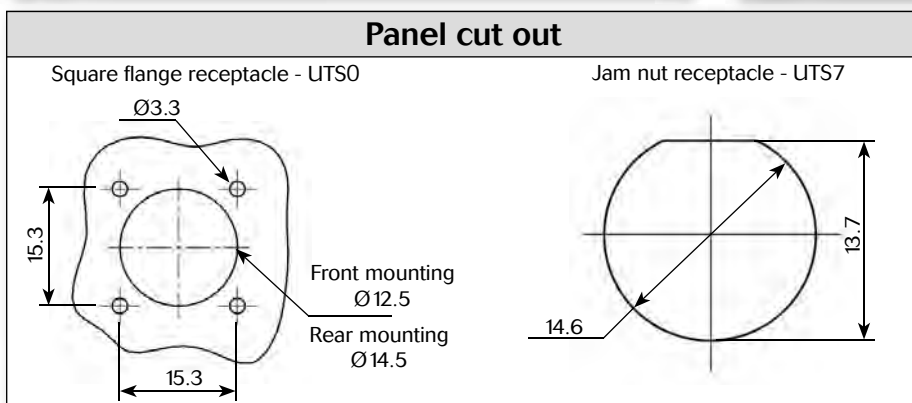
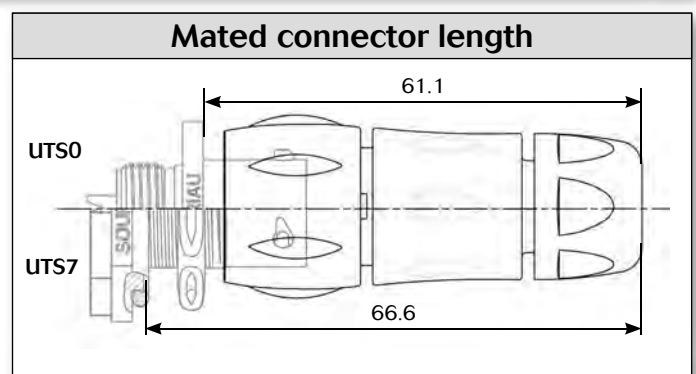
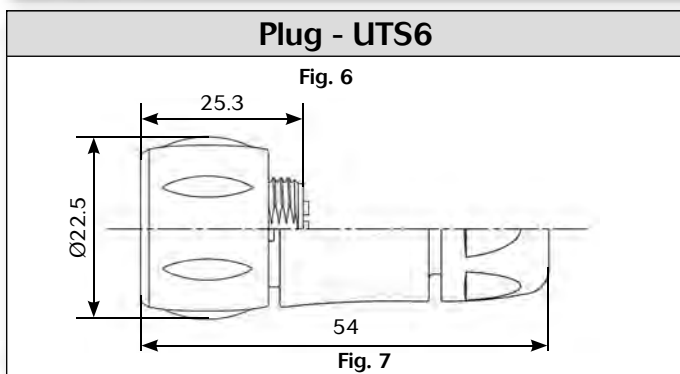
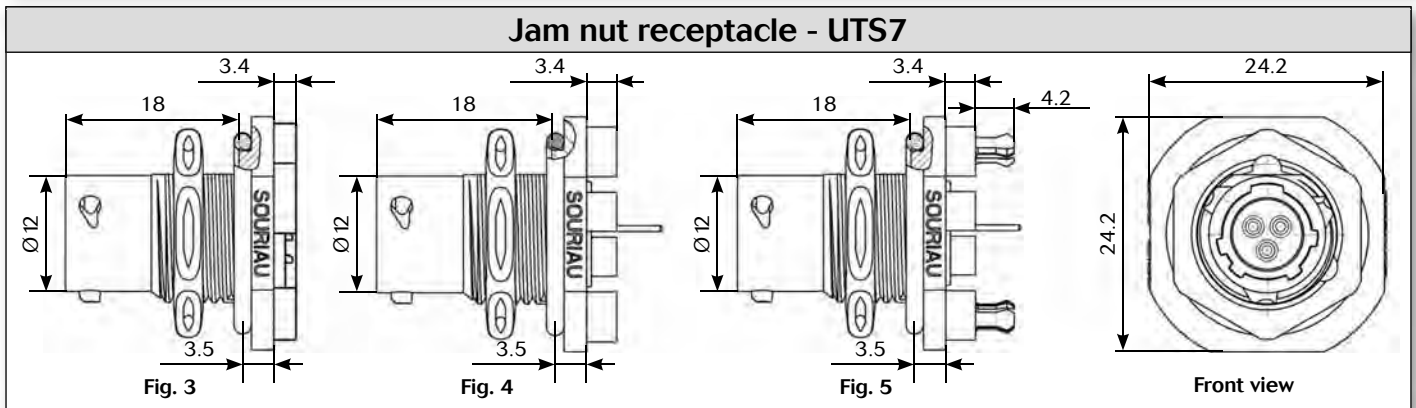
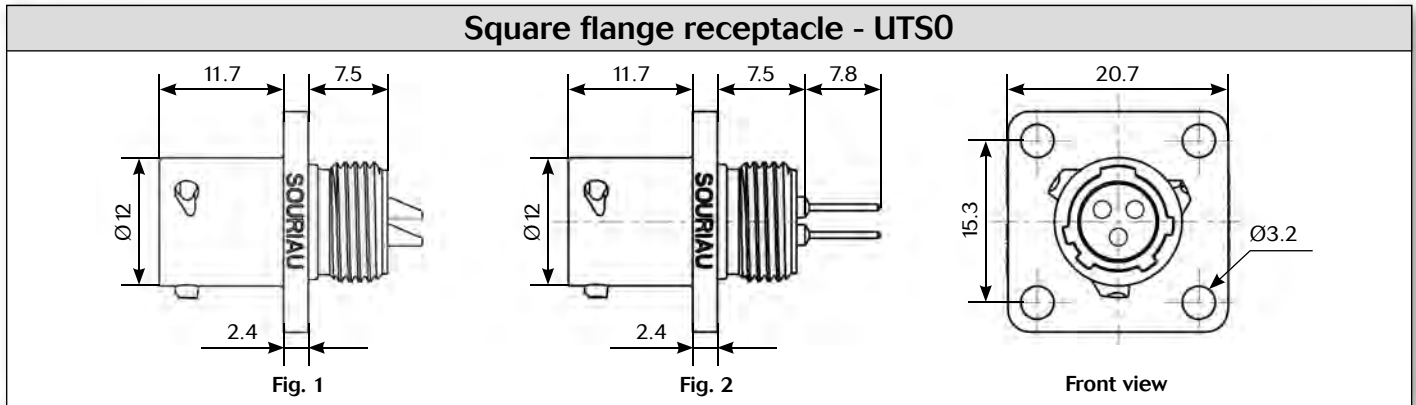

### Dimensions



Note: all dimensions are in mm



### Accessories

Jam nut sealing caps	
	
Part number	Part number
UTS8DCG	UTS8DCGR

Square flange sealing cap

Metal terminal
Part number
UTS8DCGE

Plug protective cap

IP40
Part number
UTS68C

Plastic protective cap	
	
Part numbers	
Receptacle cap	Plug cap
85005585A	85005594

Gasket

Part numbers / neoprene
UTFD11B

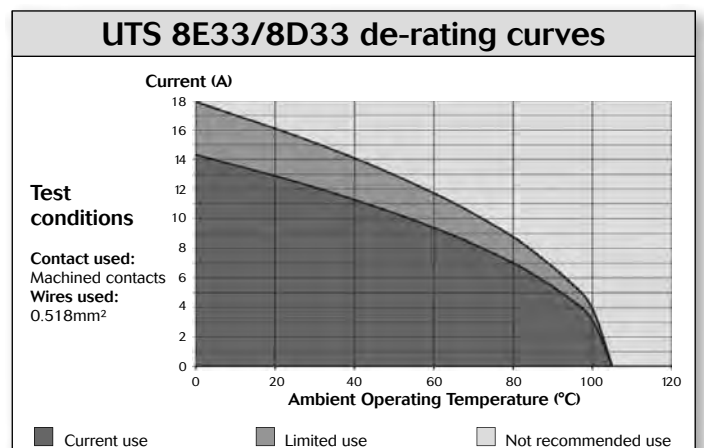
Electrical characteristics
<p><b>UL</b> 7A 250V UL94 HB</p> <p><b>CSA</b> 7A 250V UL94 HB</p> <p><b>IEC</b> 7A 50V 1.5kV 3</p>



# UTS Series

8E33/8D33





# UTS Series

## 12E3/12D3

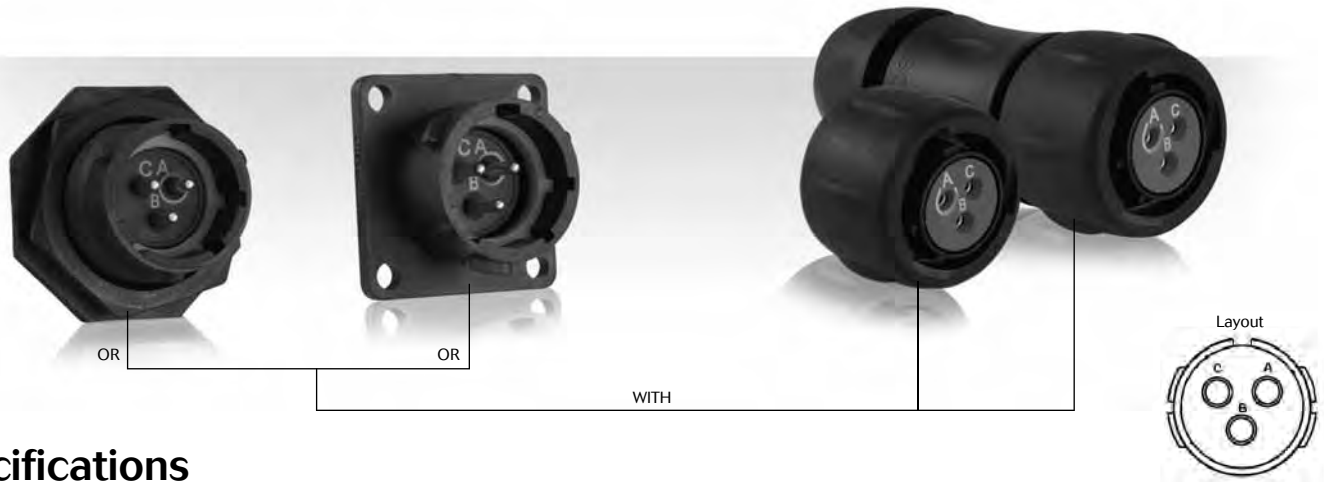

## Specifications

Contact type	Connector type	Backshell	Part number	
			Male insert	Female insert
Hand solder electrical contacts loaded	Square flange receptacle	Without (Fig.6)	UTS012E3P	UTS012E3S
	Plug	Without (Fig.1)	UTS612E3P	UTS612E3S
		Cable gland (Fig.2)	UTS6JC12E3P	UTS6JC12E3S
	Jam nut receptacle	Without (Fig.3)	UTS712E3P	UTS712E3S
PCB contacts loaded	Square flange receptacle	Without (Fig.7)	UTS012D3P	UTS012D3S
	Jam nut receptacle with stand off and with hold down clips	Without (Fig.5)	UTS712D3P32	UTS712D3S32
	Jam nut receptacle with stand off and without hold down clip	Without (Fig.4)	UTS712D3P	UTS712D3S

Sealed unmatad



### Dimensions

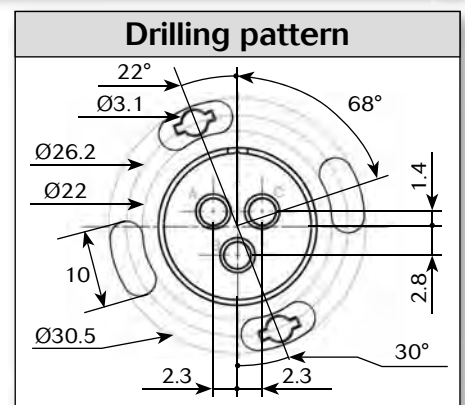
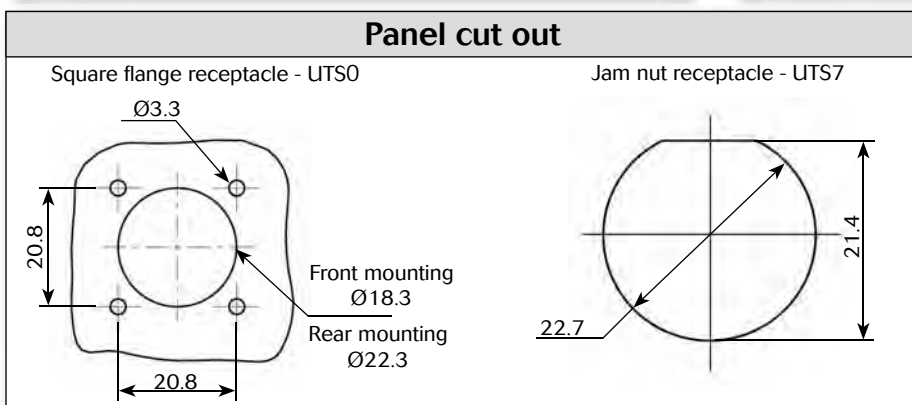
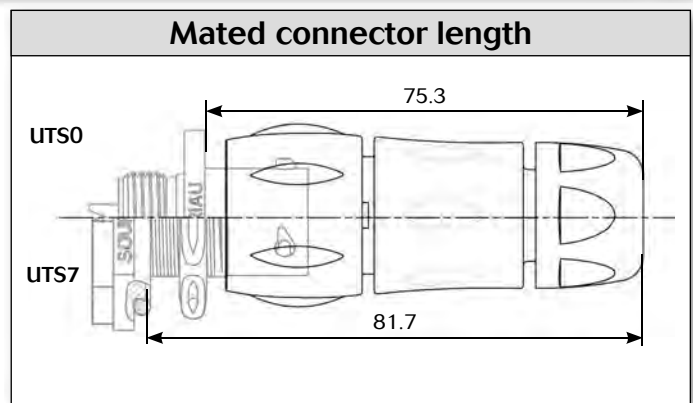
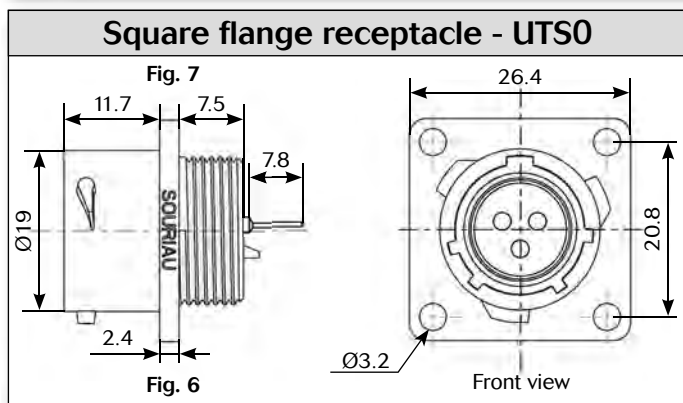
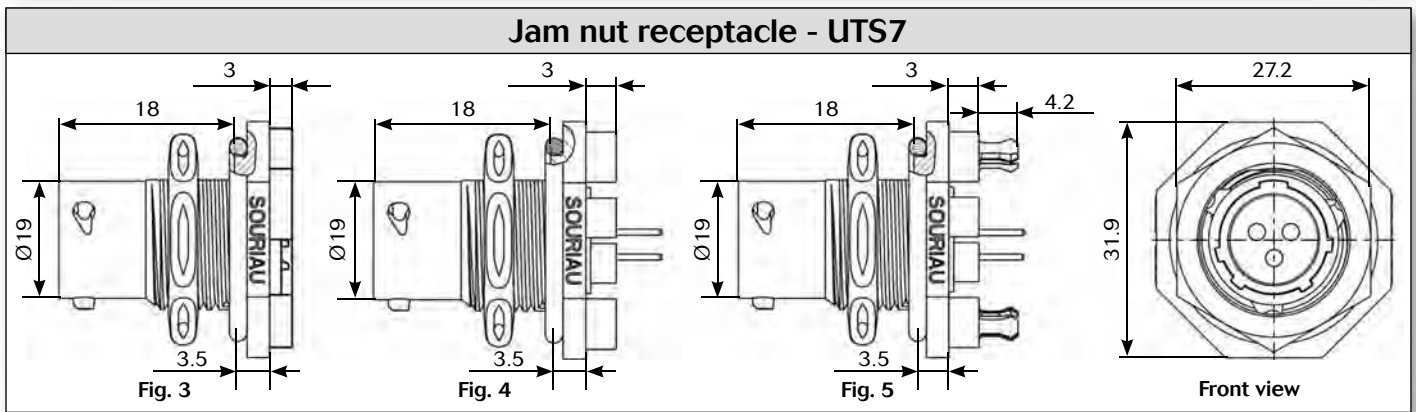
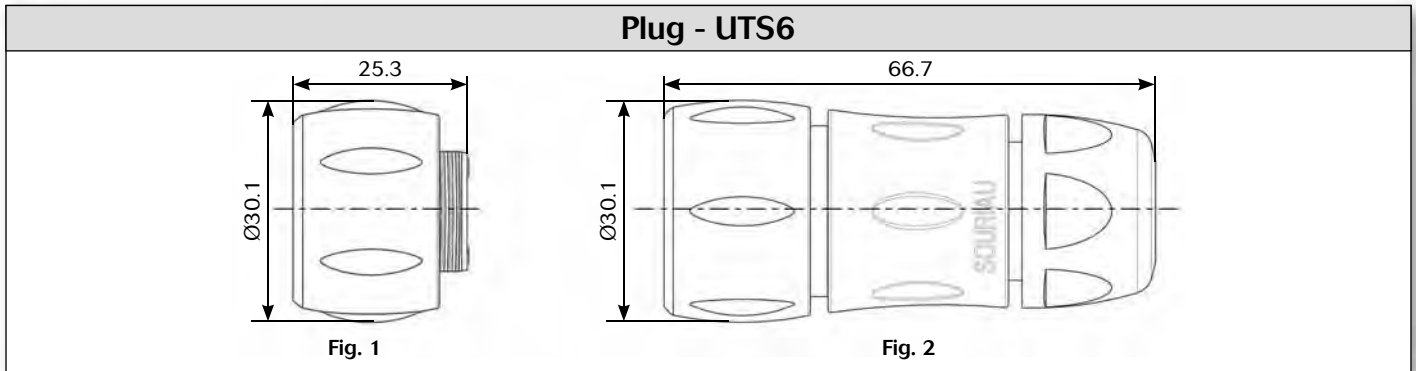

Note: all dimensions are in mm



### Accessories

#### Jam nut sealing caps

Metal terminal

Part number
UTS12DCG

Part number
UTS12DCGR

#### Plug sealing cap

Part number
UTS612DCG

#### Square flange sealing cap

Metal terminal

Part number
UTS12DCGE

#### Plastic protective cap

Part numbers	
Receptacle cap	Plug cap
85005587A	85005596

#### Gasket

Part numbers / neoprene
UTFD13B

#### Color coding rings

G for Green  
Y for Yellow  
R for Red

Part numbers	
Receptacles	Plugs
UTS712CCR	UTS612CCR
UTS712CCRY	UTS612CCRY
UTS712CCRG	UTS612CCRG

\* Add G for Green, Y for Yellow, R for Red

#### Electrical characteristics

**UL**  
13A 650V UL94 HB

**CSA**  
13A 650V UL94 HB

**IEC**  
16A 150V 2.5kV 3

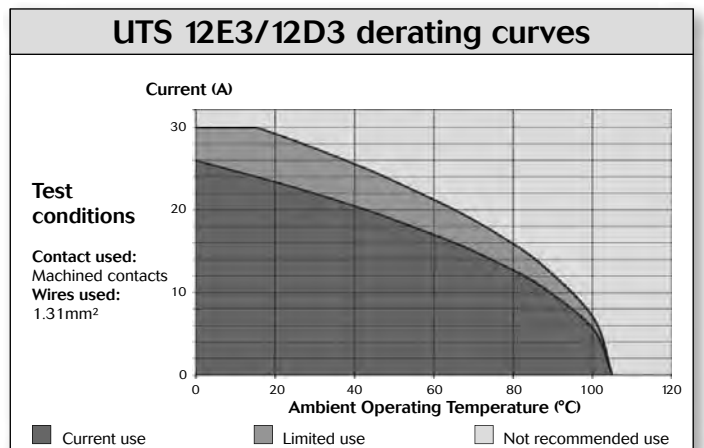

# UTS Series

12E3/12D3



# UTS Series

## 124 - 12E4/12D4

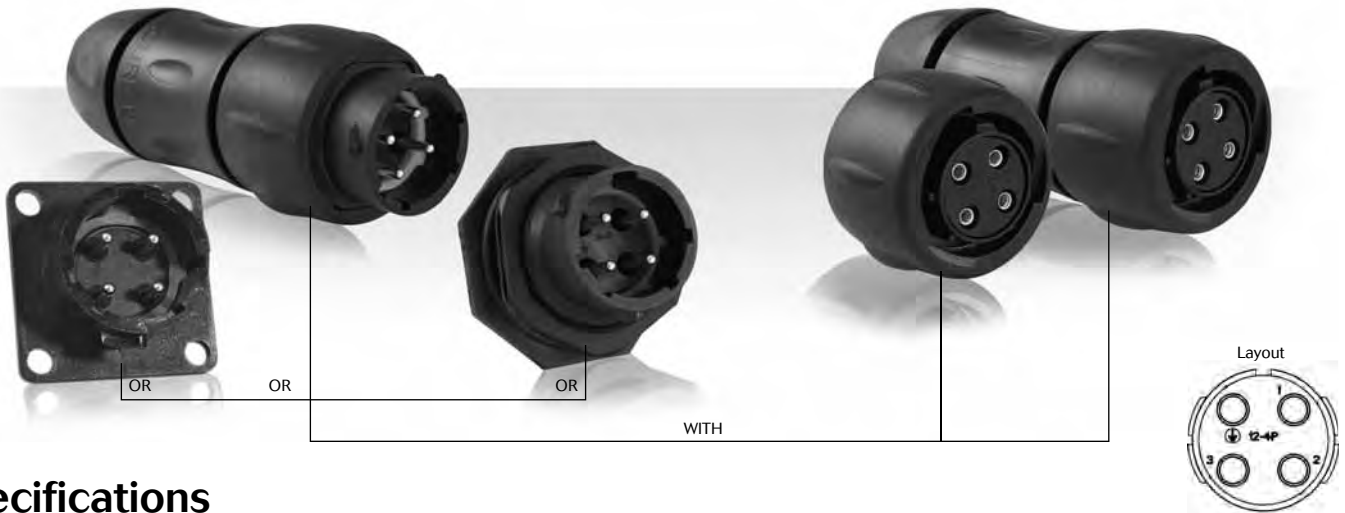
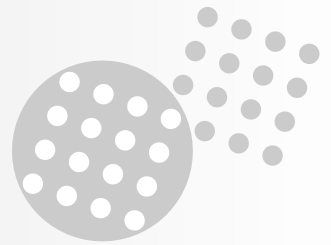

## Specifications

Contact type	Connector type	Backshell	Part number	
			Male insert	Female insert
Crimp contacts supply separately see page 55	Square flange receptacle	Without (Fig.1)	UTS0124P	
	Jam nut receptacle	Without (Fig.5)	UTS7124P	UTS7124S
	Free hanging receptacle	Cable gland (Fig. 13)	UTS1JC124P	UTS1JC124S
	Plug	Without (Fig. 11)	UTS6124P	UTS6124S
Cable gland (Fig. 12)		UTS6JC124P	UTS6JC124S	
Hand solder electrical contacts loaded	Square flange receptacle	Without (Fig.3)	UTS012E4P	UTS012E4S
	Jam nut receptacle	Without (Fig. 10)	UTS712E4P	UTS712E4S
	Plug	Without (Fig. 11)	UTS612E4P	UTS612E4S
		Cable gland (Fig. 12)	UTS6JC12E4P	UTS6JC12E4S
Screw contacts loaded	Jam nut receptacle	Without (Fig.7 & 8)	UTS7124PSCR	UTS7124SSCR
	Plug	Without (Fig. 11)	UTS6124PSCR	UTS6124SSCR
		Cable gland (Fig. 12)	UTS6JC124PSCR	UTS6JC124SSCR
	Free hanging receptacle	Cable gland (Fig. 13)	UTS1JC124PSCR	
PCB contacts supply separately see page 55	Square flange receptacle	Without (Fig.4)	UTS0124P	
	Jam nut receptacle	Without (Fig.6)	UTS7124P	UTS7124S
PCB contacts loaded	Square flange receptacle	Without (Fig.2)	UTS012D4P	UTS012D4S
	Jam nut receptacle with stand off and without hold down clip	Without (Fig.9)	UTS712D4P	UTS712D4S
	Jam nut receptacle with stand off and with hold down clips	Without (Fig.9)	UTS712D4P32	UTS712D4S32

Sealed unmatred



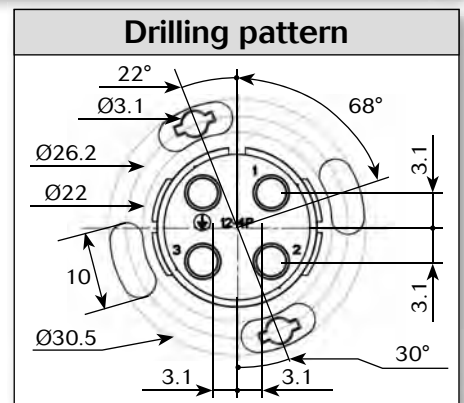
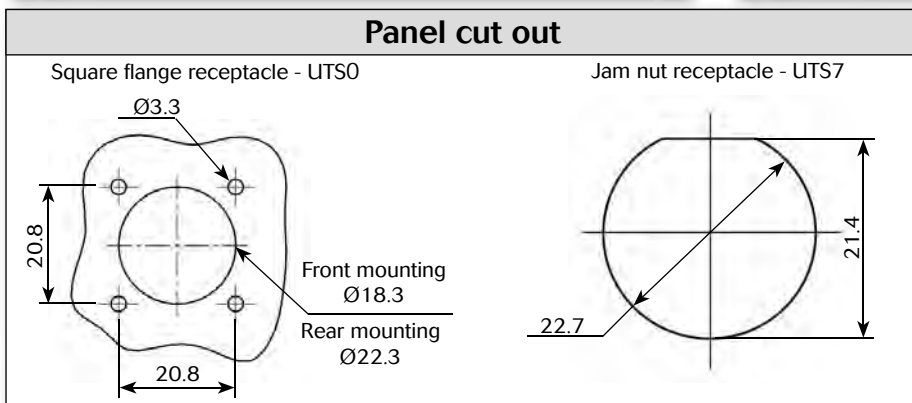
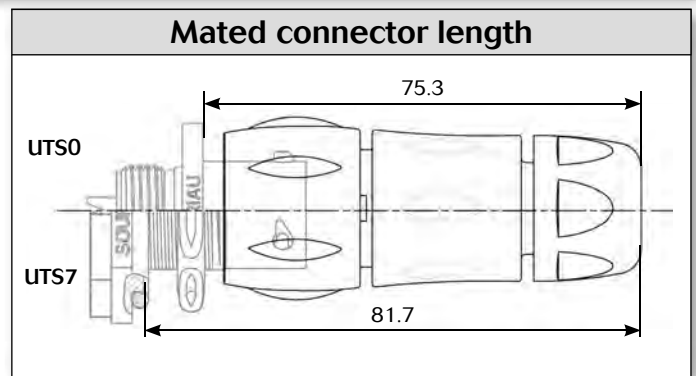
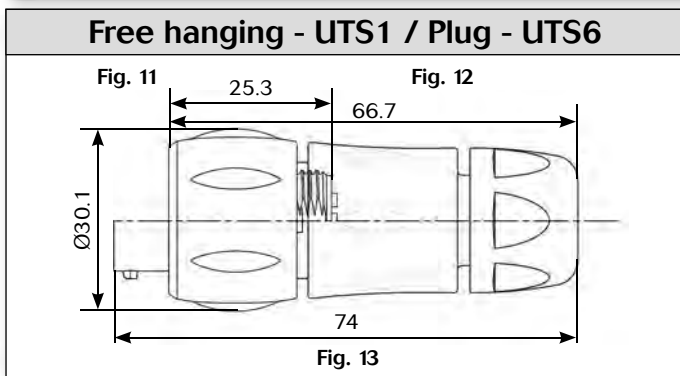
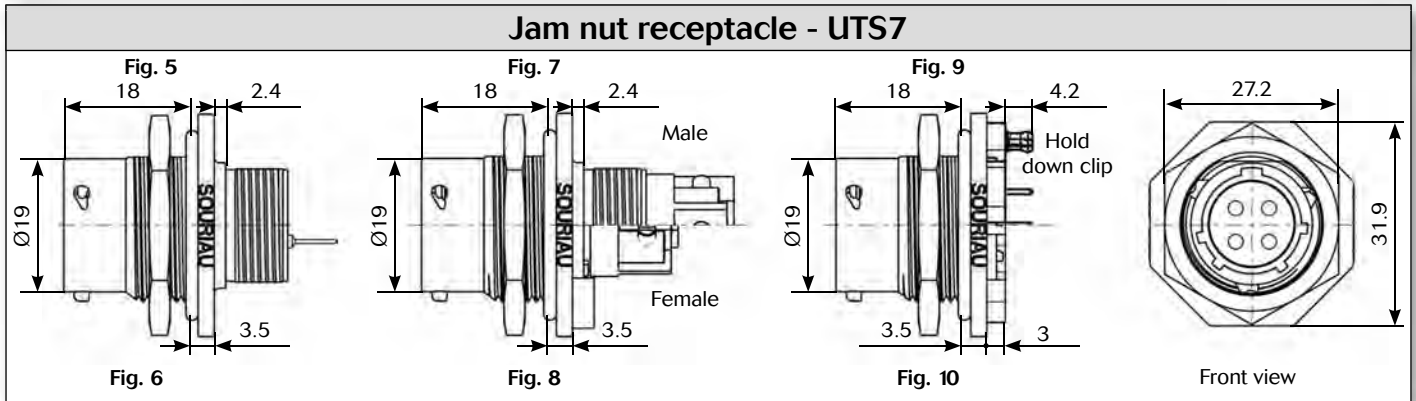
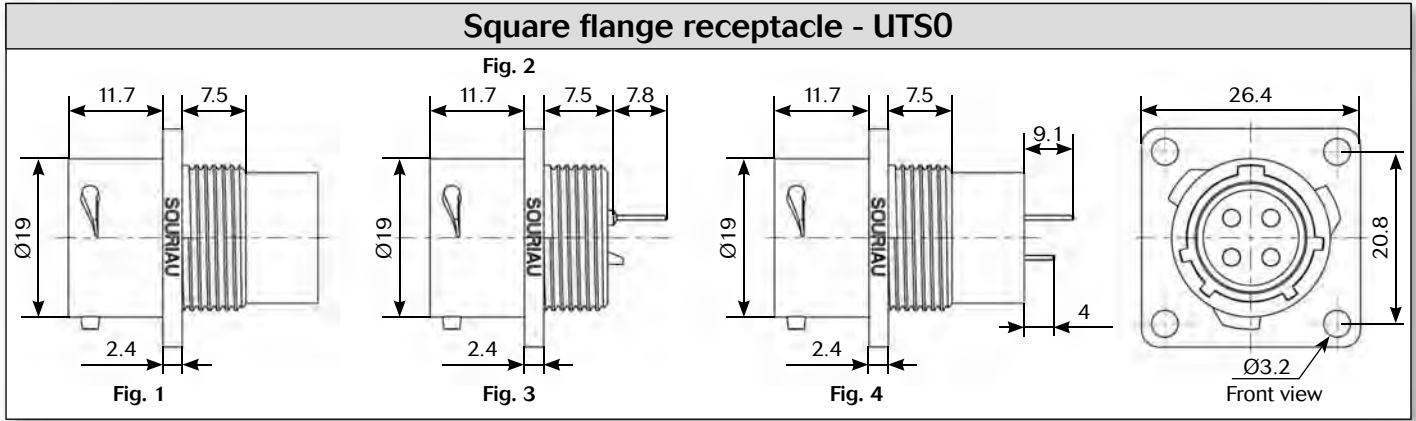

### Dimensions



Note: all dimensions are in mm



### Accessories and tooling

Jam nut sealing caps	
	
Part number	Part number
UTS12DCG	UTS12DCGR

Metal terminal

Handle

Part number
SHANGLES

Tool kit

Part number
TOOLKIT

Plug sealing cap

Part number
UTS612DCG





Square flange sealing cap

Part number
UTS12DCGE

Metal terminal

Plastic protective cap	
	
Part numbers	
Receptacle cap	Plug cap
85005587A	85005596

Gasket

Part numbers / neoprene
UTFD13B

Color coding rings												
G for Green		<table border="1"> <thead> <tr> <th colspan="2">Part numbers</th> </tr> <tr> <th>Receptacles</th> <th>Plugs</th> </tr> </thead> <tbody> <tr> <td>UTS712CCRR</td> <td>UTS612CCRR</td> </tr> <tr> <td>UTS712CCRY</td> <td>UTS612CCRY</td> </tr> <tr> <td>UTS712CCRG</td> <td>UTS612CCRG</td> </tr> </tbody> </table>	Part numbers		Receptacles	Plugs	UTS712CCRR	UTS612CCRR	UTS712CCRY	UTS612CCRY	UTS712CCRG	UTS612CCRG
Part numbers												
Receptacles	Plugs											
UTS712CCRR	UTS612CCRR											
UTS712CCRY	UTS612CCRY											
UTS712CCRG	UTS612CCRG											
Y for Yellow												
R for Red												
												

\* Add G for Green, Y for Yellow, R for Red

Crimp tooling			
			
Contacts	Contact size	Part number of head	
RM/RC 28M1K <sup>(1)</sup>	Standard contacts #16 Ø 1.6mm	S16RCM20	
RM/RC 24M9K <sup>(1)</sup>		S16RCM20	
RM/RC 20M13K <sup>(1)</sup>		S16RCM20	
RM/RC 20M12K <sup>(1)</sup>		S16RCM20	
RM/RC 16M23K <sup>(1)</sup>		S16RCM16	
RM/RC 14M50K <sup>(1)</sup>		S16RCM1450	
RM/RC 14M30K <sup>(1)</sup>		S16RCM14	
SM/SC 24ML1TK6 <sup>(1)</sup>		S16SCM20	
SM/SC 20ML1TK6 <sup>(1)</sup>		S16SCM20	
SM/SC 16ML1TK6 <sup>(1)</sup>		S16SCML1	
SM/SC 14ML1TK6 <sup>(1)</sup>		S16SCML1	
SM/SC 16ML1TK6 <sup>(1)</sup>		S16SCML11	
RMDXK10D28K		Coaxial contacts	M10S-1J
RCDXK1D28K			M10S-1J
RM/RC DX60xxD28K	M10S-1J		
RM/RC DXK10D28 + york090	M10S-1J		
RM/RC DX60xxD28		M10S-1J	

(1): example of plating, for other plating see UTS catalog page 143

# UTS Series

## 124 - 12E4/12D4



3 + ground  
16A/300V  
per IEC 61984

### Contacts

#16	Contact type	AWG	Part number		Max wire Ø	Max insulator Ø
			Male	Female		
Crimp	Machined	30-28	RM28M1K <sup>(1)</sup>	RC28M1K <sup>(1)</sup>	0.55	1.1
		26-24	RM24M9K <sup>(1)</sup>	RC24M9K <sup>(1)</sup>	0.8	1.6
		22-20	RM20M13K <sup>(1)</sup>	RC20M13K <sup>(1)</sup>	1.18	1.8
		22-20	RM20M12K <sup>(1)</sup>	RC20M12K <sup>(1)</sup>	1.18	2.2
		20-16	RM16M23K <sup>(1)</sup>	RC16M23K <sup>(1)</sup>	1.8	3.2
		16-14	RM14M50K <sup>(1)</sup>	RC14M50K <sup>(1)</sup>	2.05	3.2
		16-14	RM14M30K <sup>(1)</sup>	RC14M30K <sup>(1)</sup>	2.28	3.2
	Stamped & formed reeled contacts	26-24	SM24M1TK6 <sup>(1)(2)</sup>	SC24M1TK6 <sup>(1)(2)</sup>	0.89-1.28	-
		22-20	SM20M1TK6 <sup>(1)(2)</sup>	SC20M1TK6 <sup>(1)(2)</sup>	1.17-2.08	-
		18-16	SM16M1TK6 <sup>(1)(2)</sup>	SC16M1TK6 <sup>(1)(2)</sup>	3.0	-
18-16		SM16M11TK6 <sup>(1)(2)</sup>	SC16M11TK6 <sup>(1)(2)</sup>	2.0-3.0	-	
14		SM14M1TK6 <sup>(1)(2)</sup>	SC14M1TK6 <sup>(1)(2)</sup>	3.2	-	
PCB	Machined <sup>(3)</sup>	-	RM20M12E8K <sup>(1)</sup>	RC20M12E84K <sup>(1)</sup>	-	-
Coaxial	Cable Multipiece	-	RMDXK10D28	RCDXK1D28	-	-
	Cable Monocrimp	-	RMDX60xxD28	RCDX60xxD28	-	-
	Twisted pair Multipiece	-	RMDXK10D28 + york090	RCDXK1D28 + york090	-	-
	Twisted pair Monocrimp	-	RMDX60xxD28	RCDX60xxD28	-	-
Fiber optic	POF contacts Plastic optical fibre	-	RMPOF1000	RCPOF1000B	-	-

(1): Example of plating, for other plating see page 143  
 (2): Loose piece contact available if putting L. Example: SM20ML1-TK6  
 (3): For dimensions see page 148

#### Electrical characteristics

**UL**  
10A 500V UL94 V-0

**CSA**  
7A 500V UL94 V-0

**IEC**  
16A 300V 4kV 3  
Temperature elevation: 50°C

#### UTS 124 derating curves

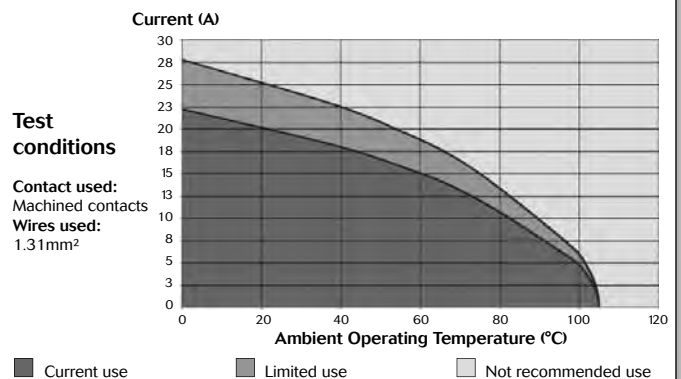



# UTS Series 183G1

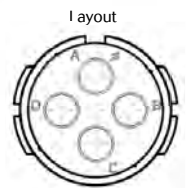

## Specifications

Contact type	Connector type	Backshell	Part number	
			Male insert	Female insert
Crimp contacts supply separately see page 59	NPT threaded receptacle	Without (Fig.1)		UTS7183G1SNPT
	Plug	Without (Fig.2)	UTS6183G1P	
	Plug	Cable gland (Fig.3)	UTS6JC183G1P	



Dimensions

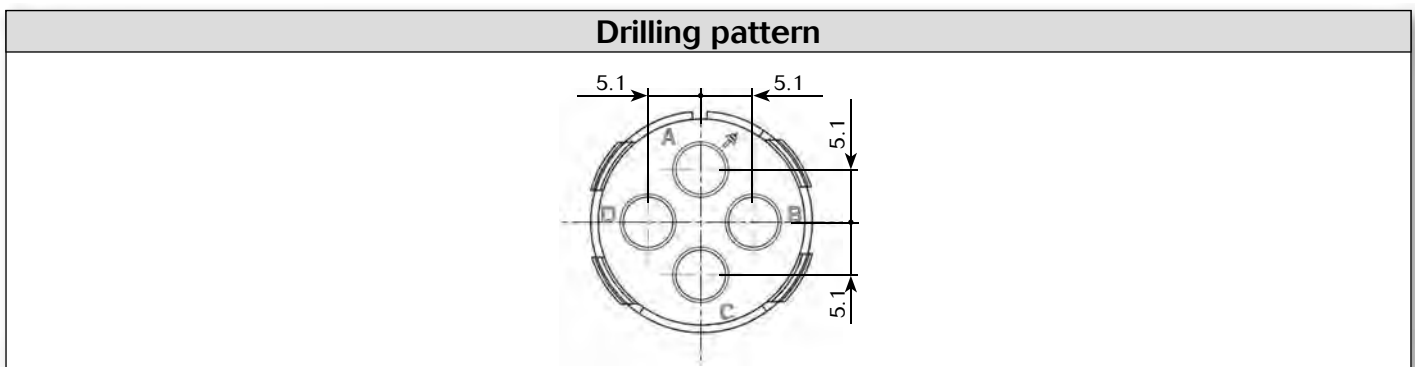
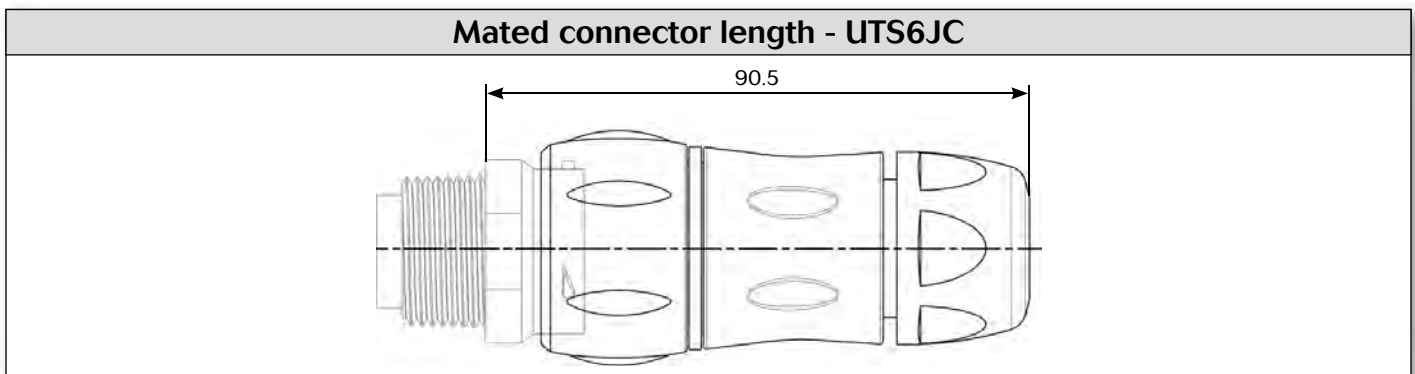
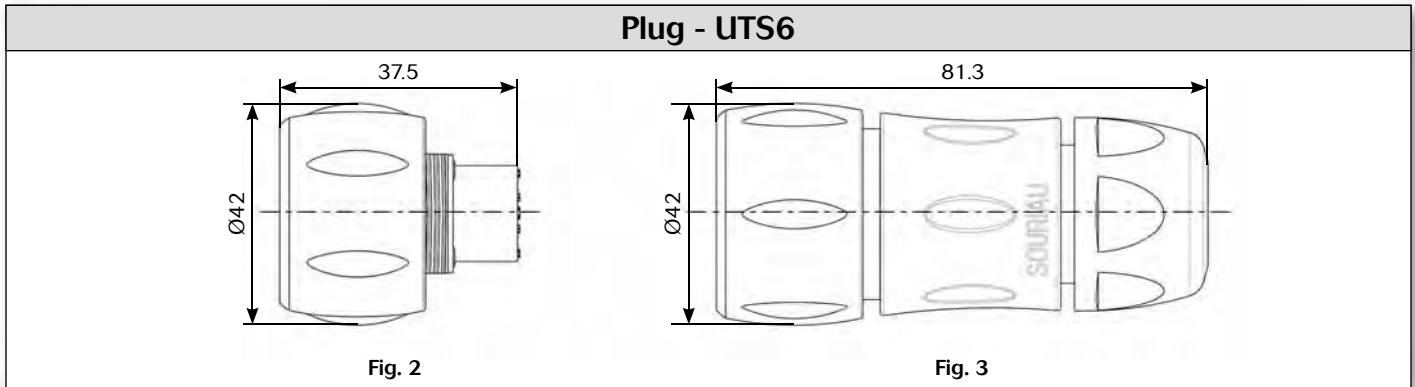
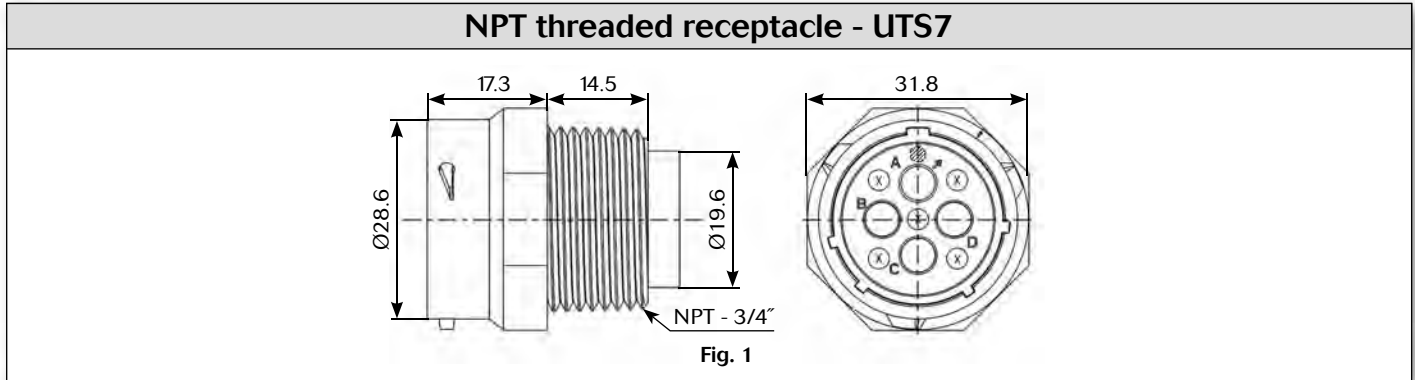

Note: all dimensions are in mm



### Accessories and tooling

Jam nut sealing caps	
	
Part number	Part number
UTS14DCG	UTS14DCGR

Metal terminal

Hand tool

Part number
M317

Plug sealing cap

Part number
UTS614DCG

Positioner + locator setting



Part number
VGE10078A

Plastic protective cap	
	
Part numbers	
Receptacle cap	Plug cap
85005588A	85005597

Gasket

Part numbers / neoprene
UTFD14B

Extraction tool

Part number
51060210936

Color coding rings	
G for Green	
Y for Yellow	
R for Red	
Part numbers	
Receptacles	Plugs
UTS714CCRR	UTS614CCRR
UTS714CCRY	UTS614CCRY
UTS714CCRG	UTS614CCRG

\* Add G for Green, Y for Yellow, R for Red



3 + ground  
32A/300V  
per IEC 61984

### Contacts

#8	Contact type	AWG	Part number		Max wire Ø	Max insulator Ø
			Male	Female		
Crimp	Machined	16	82913601A <sup>(1)</sup>	82913600A <sup>(1)</sup>	-	6.5
		14	82913603A <sup>(1)</sup>	82913602A <sup>(1)</sup>	-	
		12	82913605A <sup>(1)</sup>	82913604A <sup>(1)</sup>	-	
		10	82913607A <sup>(1)</sup>	82913606A <sup>(1)</sup>	-	
		8	82913609A <sup>(1)</sup>	82913608A <sup>(1)</sup>	-	

(1): Example of plating, for other plating see page 143

Electrical characteristics
<p><b>UL</b> 23A 600V UL94 V-0</p> <p><b>CSA</b> 23A 600V UL94 V-0</p> <p><b>IEC</b> 32A 300V 4kV 3</p>

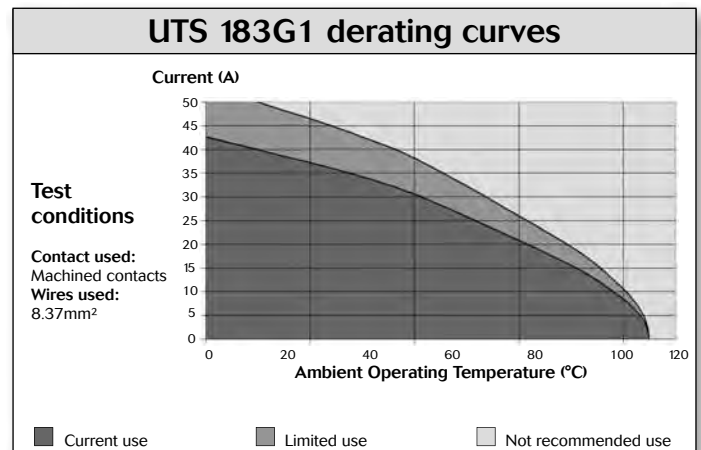

# UTS Series

## 8E4/8D4

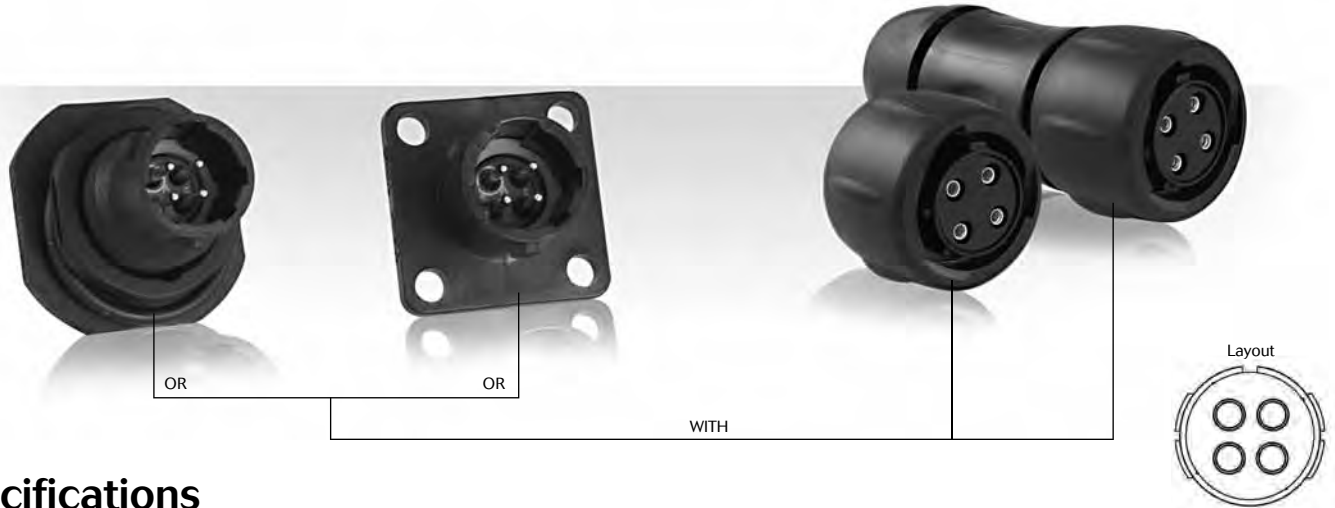

### Specifications

Contact type	Connector type	Backshell	Part number	
			Male insert	Female insert
Hand solder electrical contacts loaded	Square flange receptacle	Without (Fig.1)	UTS08E4P	UTS08E4S
	Plug	Without (Fig.6)	UTS68E4P	UTS68E4S
		Cable gland (Fig.7)	UTS6JC8E4P	UTS6JC8E4S
	Jam nut receptacle	Without (Fig.3)	UTS78E4P	UTS78E4S
PCB contacts loaded	Square flange receptacle	Without (Fig.2)	UTS08D4P	UTS08D4S
	Jam nut receptacle with stand off and with hold down clips	Without (Fig.5)	UTS78D4P32	UTS78D4S32
	Jam nut receptacle with stand off and without hold down clip	Without (Fig.4)	UTS78D4P	UTS78D4S

Sealed unmated



### Dimensions

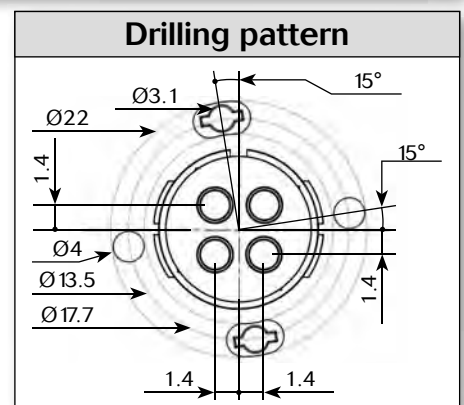
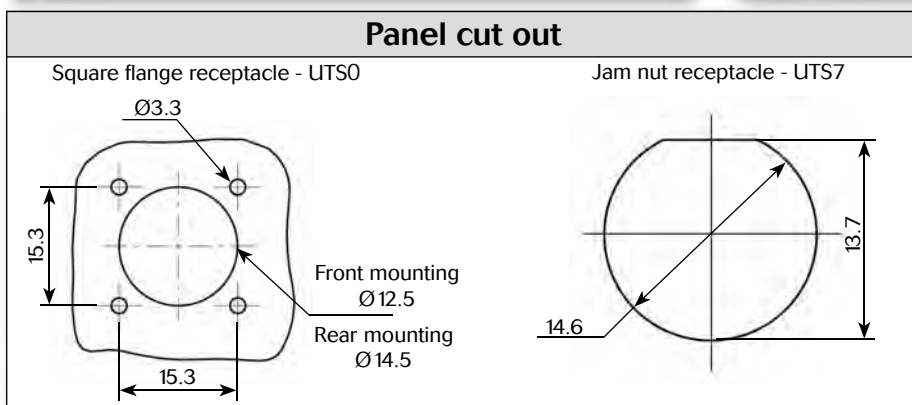
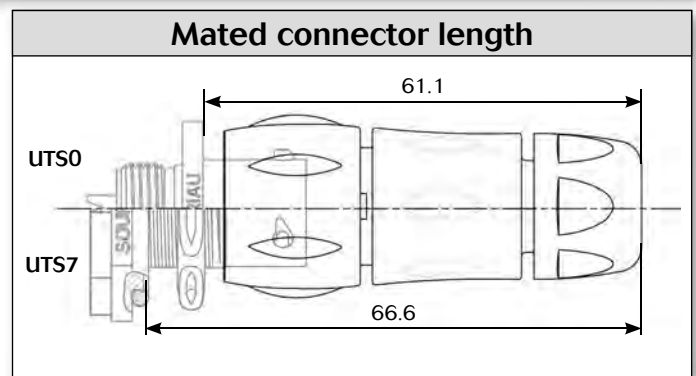
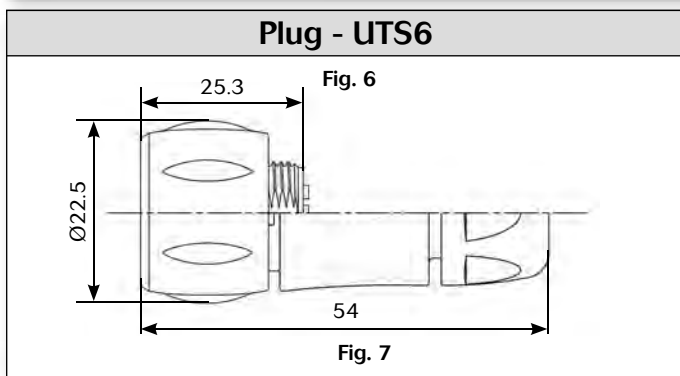
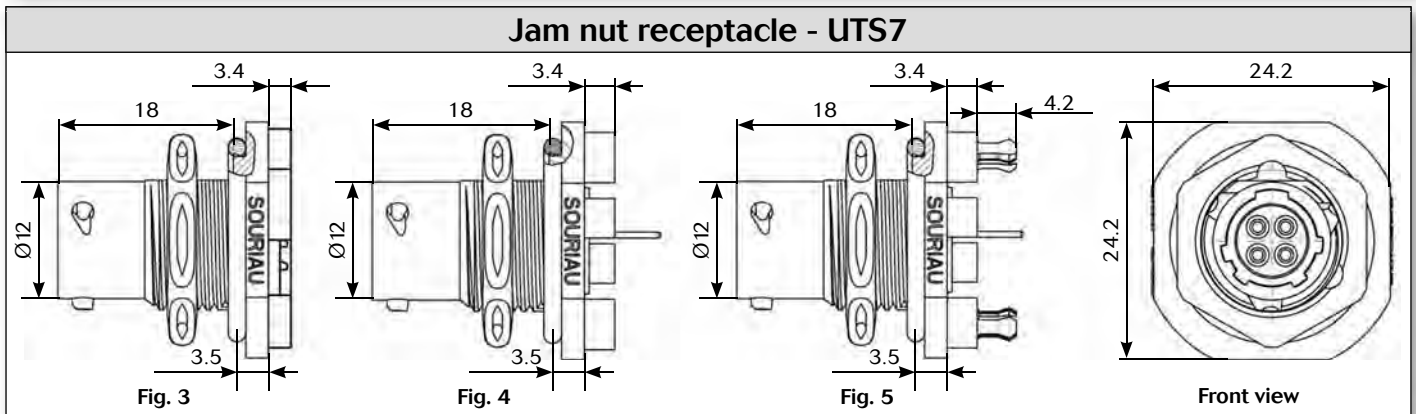
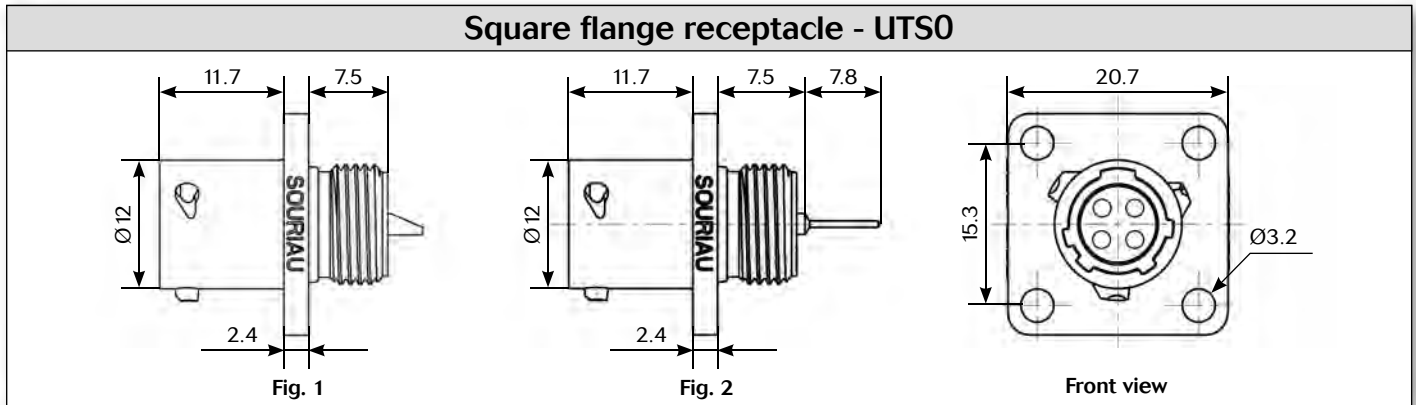

Note: all dimensions are in mm



### Accessories

#### Jam nut sealing caps

Part number	Part number
UTS8DCG	UTS8DCGR

#### Square flange sealing cap

Metal terminal

Part number
UTS8DCGE

#### Plug protective cap

IP40

Part number
UTS68C

#### Plastic protective cap

Part numbers	
Receptacle cap	Plug cap
85005585A	85005594

#### Gasket

Part numbers / neoprene
UTFD11B

#### Electrical characteristics

**UL**  
7A 250V UL94 HB

**CSA**  
7A 250V UL94 HB

**IEC**  
7A 32V 1.5kV 3

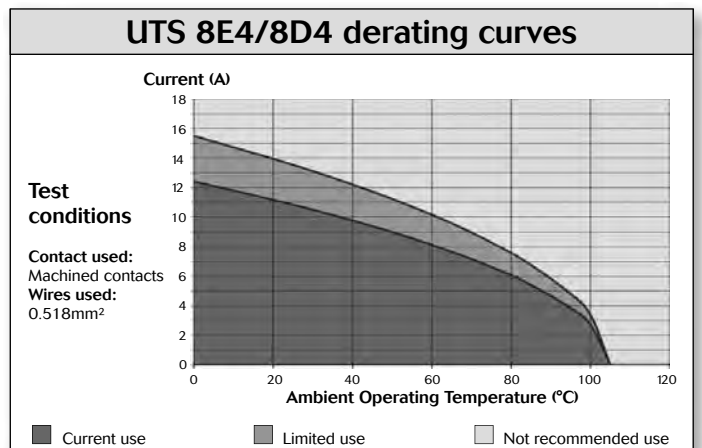

# UTS Series

## 8E4/8D4





# UTS Series

102W2 (2x#12 + 2x#20)

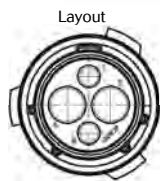

## Specifications

Contact type	Connector type	Backshell	Part number	
			Male insert	Female insert
Crimp contacts supply separately see page 67	Free hanging receptacle	Cable gland (Fig.1)	UTS1JC102W2P	UTS1JC102W2S
	Plug	Without (Fig.2)	UTS6102W2P	UTS6102W2S
	Plug	Cable gland (Fig.3)	UTS6JC102W2P	UTS6JC102W2S
	Jam nut receptacle	Without (Fig.4)	UTS7102W2P	UTS7102W2S

# UTS Series

102W2 (2x#12 + 2x#20)



4 contacts  
25A/150V  
per IEC 61984

## Dimensions

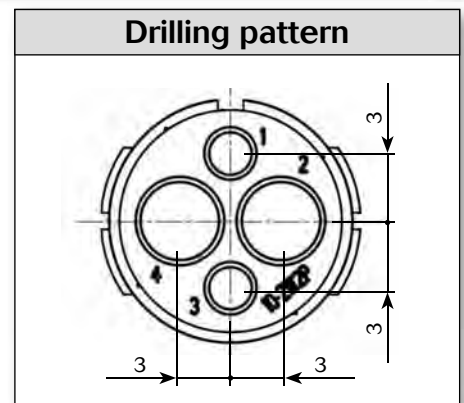
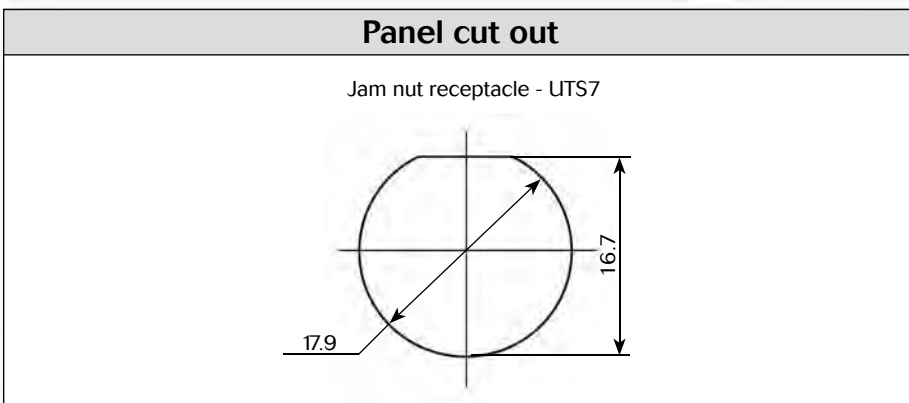
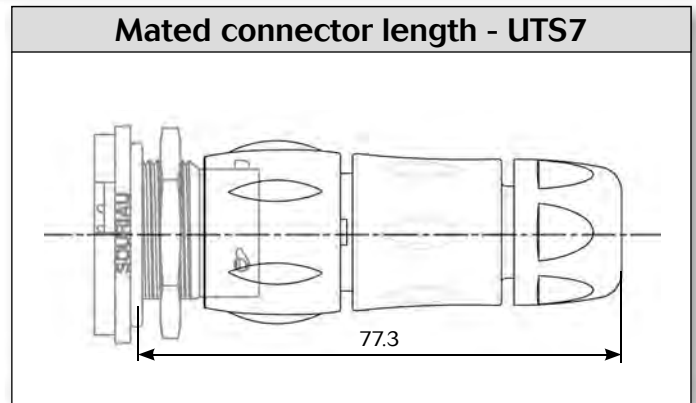
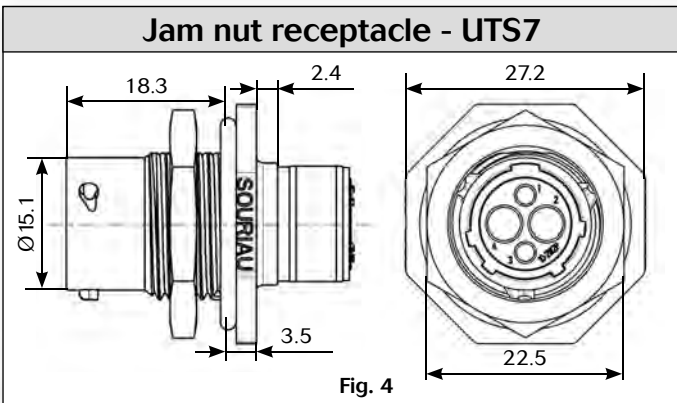
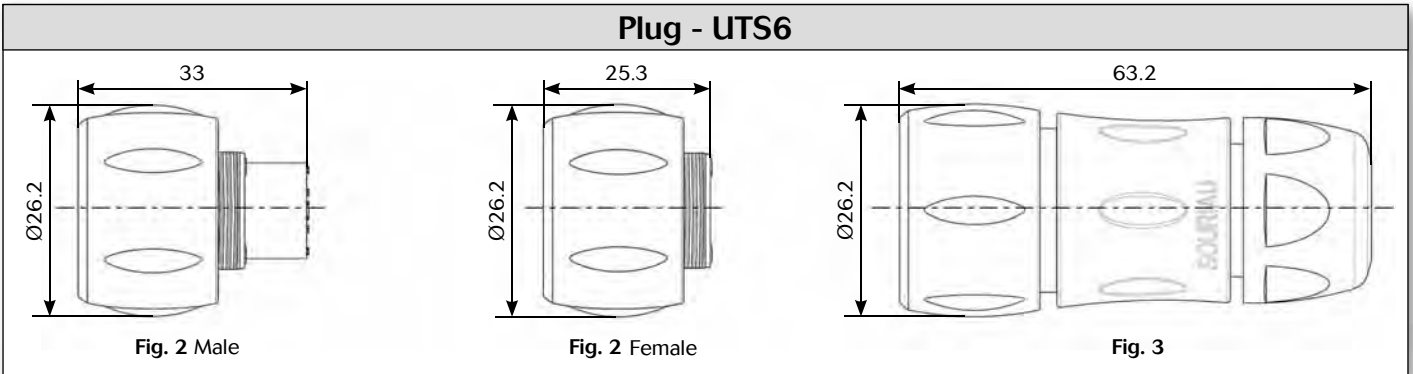
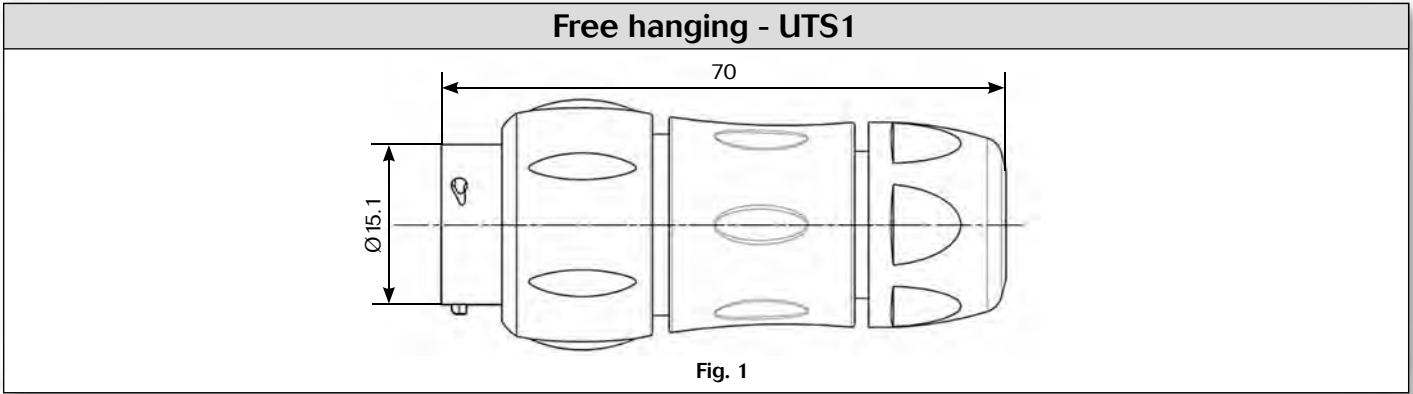

Note: all dimensions are in mm

# UTS Series

102W2 (2x#12 + 2x#20)



## Accessories and tooling

### Jam nut sealing caps

Metal terminal

Part number	Part number
UTS10DCG	UTS10DCGR

### Plug sealing cap

Part number
UTS610DCG

### Plastic protective cap

Part numbers	
Receptacle cap	Plug cap
85005586A	85005595

### Gasket

Part numbers / neoprene
UTFD12B

### Color coding rings

G for Green  
Y for Yellow  
R for Red

Part numbers	
Receptacles	Plugs
UTS710CCRR	UTS610CCRR
UTS710CCRY	UTS610CCRY
UTS710CCRG	UTS610CCRG

\* Add G for Green, Y for Yellow, R for Red

### Crimp tooling #20

Part number	Part number
SHANDLES	TOOLKIT

Contacts	Contact size	Part number of head
RM/RC 24W3K <sup>(1)</sup>	Standard contacts #20 Ø 1mm	S20RM
RM/RC 20W3K <sup>(1)</sup>		S20RM
RM/RC 18W3K <sup>(1)</sup>		S20RM
SM/SC 24W3S <sup>(2)</sup>		S20SCM20
SM/SC 24WL3S <sup>(3)</sup>		S20SCM20
SM/SC 20W3S <sup>(2)</sup>		S20SCM20
SM/SC 20WL3S <sup>(3)</sup>	S20SCM20	

(1): example of plating, for other plating see UTS catalog page 148  
(2): contact reeled (3): loose contact

### Crimp tooling #12

Part number hand tool	Part number positioner + locator setting
M317	VGE10078A

Part number extraction tool
51060210924

# UTS Series

102W2 (2x#12 + 2x#20)



4 contacts  
25A/150V  
per IEC 61984

## Contacts

#20	Contact type	AWG	Part number		Max insulator Ø
			Male	Female	
Crimp	Machined	26-24	RM24W3K <sup>(1)</sup>	RC24W3K <sup>(1)</sup>	1.58
		22-20	RM20W3K <sup>(1)</sup>	RC20W3K <sup>(1)</sup>	1.58
		20-18	RM18W3K <sup>(1)</sup>	RC18W3K <sup>(1)</sup>	2.1
	stamped & formed reeled contacts	26-24	SM24W3TK6 <sup>(2)</sup>	SC24W3TK6 <sup>(2)</sup>	0.89-1.58
		26-24	SM24W3S26 <sup>(2)</sup>	SC24W3S25 <sup>(2)</sup>	0.89-1.58
		22-20	SM20W3TK6 <sup>(2)</sup>	SC20W3TK6 <sup>(2)</sup>	1.17-2.08
		22-20	SM20W3S26 <sup>(2)</sup>	SC20W3S25 <sup>(2)</sup>	1.17-2.08
	PCB	Machined <sup>(3)</sup>	-	RMW5016K	RCW5016K
#12					
Crimp	Machined	22	82911457NA	82911456A	4.9
		20	82911459NA	82911458A	
		18	82911461NA	82911460A	
		16	82911463NA	82911462A	
		14	82911465NA	82911464A	
		12	82911467NA	82911466A	

(1): Example of plating, for other plating see page 143  
 (2): Loose piece contact available if putting L. Example: SM20ML1-TK6  
 (3): For dimensions see page 148

Mechanics

Electrical characteristics
<p><b>UL</b> 20A 500V UL94 V-0</p> <p><b>CSA</b> 18A 500V UL94 V-0</p> <p><b>IEC</b> 25A 150V 2.5kV 3 Temperature elevation: 50°C</p>

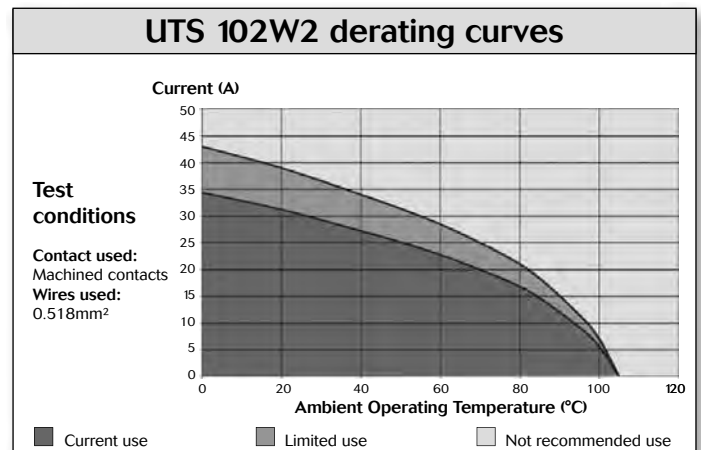

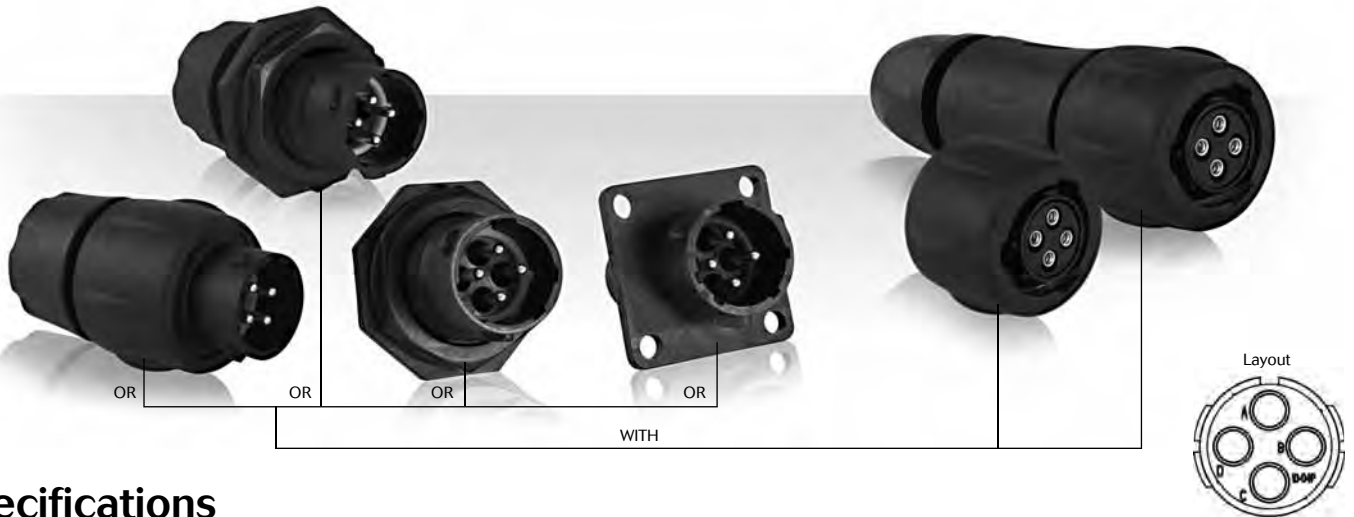

## Specifications

Contact type	Connector type	Backshell	Part number	
			Male insert	Female insert
Crimp contact supply separately see next page 71	Square flange receptacle	Without (Fig.1)	UTS0104P	UTS0104S
	Free hanging receptacle	Cable gland and grommet (Fig.2)	UTS1GJC104P	
	Free hanging receptacle	Nut and grommet (Fig.3)	UTS1GN104P	
	Free hanging receptacle	Cable gland (Fig.2)	UTS1JC104P	UTS1JC104S
	Plug	Without (Fig.4)	UTS6104P	UTS6104S
	Plug	Cable gland and grommet (Fig.5)		UTS6GJC104S
	Plug	Nut and grommet (Fig.6)		UTS6GN104S
	Plug	Cable gland (Fig.5)	UTS6JC104P	UTS6JC104S
	Jam nut receptacle	Without (Fig.7)	UTS7104P	UTS7104S
	Jam nut receptacle	Cable gland and grommet (Fig.9)	UTS7GJC104P	
	Jam nut receptacle	Nut and grommet (Fig.8)	UTS7GN104P	



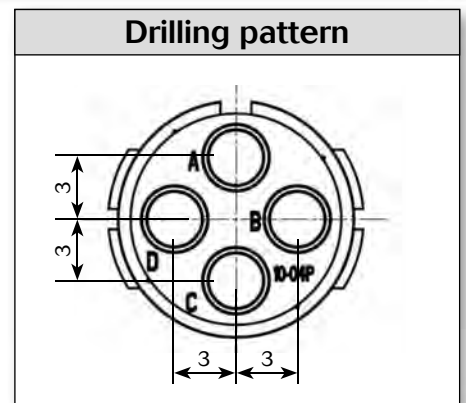
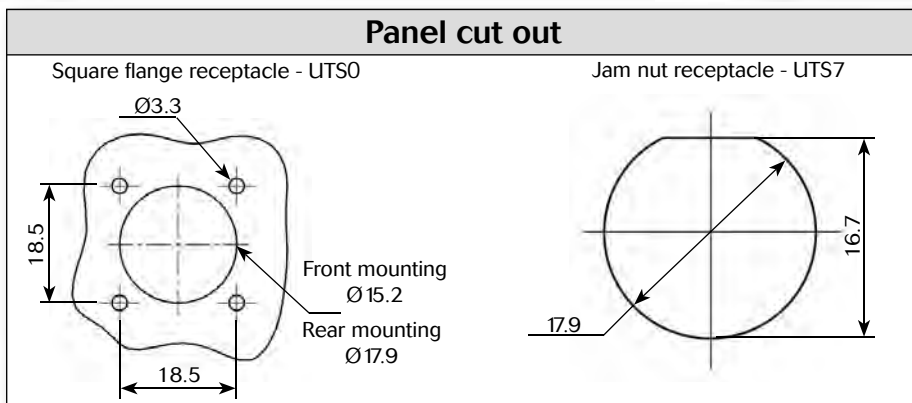
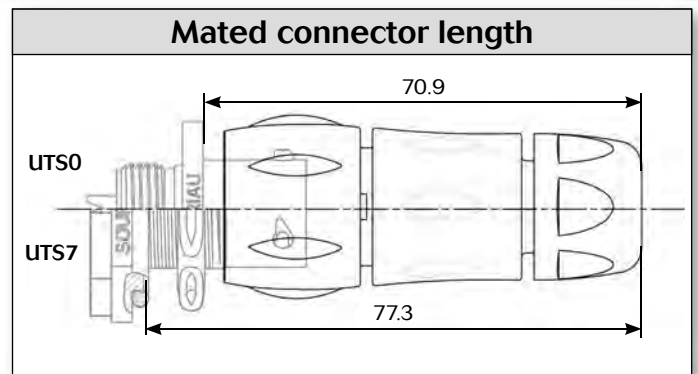
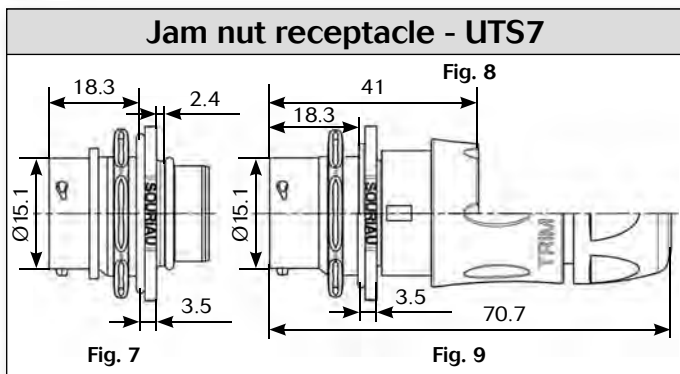
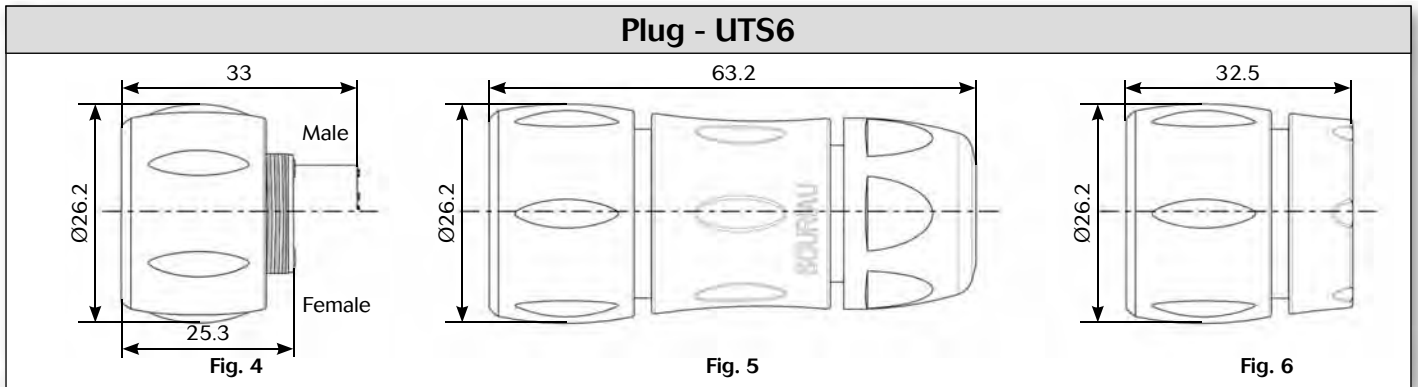
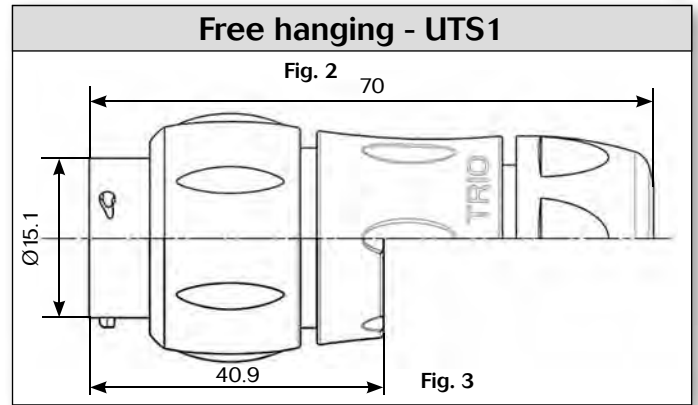
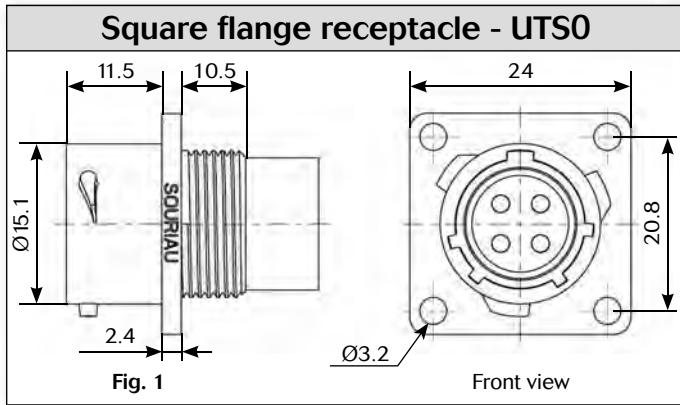

### Dimensions



Note: all dimensions are in mm



### Accessories and tooling

Jam nut sealing caps	
	
Part number	Part number
UTS10DCG	UTS10DCGR

Metal terminal

Handle

Part number
SHANGLES

Tool kit

Part number
TOOLKIT

Plug sealing cap

Part number
UTS610DCG





Square flange sealing cap

Part number
UTS10DCGE

Metal terminal

Plastic protective cap	
	
Part numbers	
Receptacle cap	Plug cap
85005586A	85005595

Gasket

Part numbers / neoprene
UTFD12B

Color coding rings												
G for Green		<table border="1"> <thead> <tr> <th colspan="2">Part numbers</th> </tr> <tr> <th>Receptacles</th> <th>Plugs</th> </tr> </thead> <tbody> <tr> <td>UTS710CCRR</td> <td>UTS610CCRR</td> </tr> <tr> <td>UTS710CCRY</td> <td>UTS610CCRY</td> </tr> <tr> <td>UTS710CCRG</td> <td>UTS610CCRG</td> </tr> </tbody> </table>	Part numbers		Receptacles	Plugs	UTS710CCRR	UTS610CCRR	UTS710CCRY	UTS610CCRY	UTS710CCRG	UTS610CCRG
Part numbers												
Receptacles	Plugs											
UTS710CCRR	UTS610CCRR											
UTS710CCRY	UTS610CCRY											
UTS710CCRG	UTS610CCRG											
Y for Yellow												
R for Red												
												

\* Add G for Green, Y for Yellow, R for Red

Crimp tooling			
			
Contacts	Contact size	Part number of head	
RM/RC 28M1K <sup>(1)</sup>	Standard contacts #16 Ø 1.6mm	S16RCM20	
RM/RC 24M9K <sup>(1)</sup>		S16RCM20	
RM/RC 20M13K <sup>(1)</sup>		S16RCM20	
RM/RC 20M12K <sup>(1)</sup>		S16RCM20	
RM/RC 16M23K <sup>(1)</sup>		S16RCM16	
RM/RC 14M50K <sup>(1)</sup>		S16RCM1450	
RM/RC 14M30K <sup>(1)</sup>		S16RCM14	
SM/SC 24ML1TK6 <sup>(1)</sup>		S16SCM20	
SM/SC 20ML1TK6 <sup>(1)</sup>		S16SCM20	
SM/SC 16ML1TK6 <sup>(1)</sup>		S16SCML1	
SM/SC 14ML1TK6 <sup>(1)</sup>		S16SCML1	
SM/SC 16ML1TK6 <sup>(1)</sup>		S16SCML11	
RMDXK10D28K		Coaxial contacts	M10S-1J
RCDXK1D28K			M10S-1J
RM/RC DX60xxD28K			M10S-1J
RM/RC DXK10D28 + york090	M10S-1J		
RM/RC DX60xxD28		M10S-1J	

(1): example of plating, for other plating see UTS catalog page 143



### Contacts

#16	Contact type	AWG	Part number		Max wire Ø	Max insulator Ø
			Male	Female		
Crimp	Machined	30-28	RM28M1K <sup>(1)</sup>	RC28M1K <sup>(1)</sup>	0.55	1.1
		26-24	RM24M9K <sup>(1)</sup>	RC24M9K <sup>(1)</sup>	0.8	1.6
		22-20	RM20M13K <sup>(1)</sup>	RC20M13K <sup>(1)</sup>	1.18	1.8
		22-20	RM20M12K <sup>(1)</sup>	RC20M12K <sup>(1)</sup>	1.18	2.2
		20-16	RM16M23K <sup>(1)</sup>	RC16M23K <sup>(1)</sup>	1.8	3.2
		16-14	RM14M50K <sup>(1)</sup>	RC14M50K <sup>(1)</sup>	2.05	3.2
		16-14	RM14M30K <sup>(1)</sup>	RC14M30K <sup>(1)</sup>	2.28	3.2
	Stamped & formed reeled contacts	26-24	SM24M1TK6 <sup>(1)(2)</sup>	SC24M1TK6 <sup>(1)(2)</sup>	0.89-1.28	-
		22-20	SM20M1TK6 <sup>(1)(2)</sup>	SC20M1TK6 <sup>(1)(2)</sup>	1.17-2.08	-
		18-16	SM16M1TK6 <sup>(1)(2)</sup>	SC16M1TK6 <sup>(1)(2)</sup>	3.0	-
18-16		SM16M11TK6 <sup>(1)(2)</sup>	SC16M11TK6 <sup>(1)(2)</sup>	2.0-3.0	-	
14		SM14M1TK6 <sup>(1)(2)</sup>	SC14M1TK6 <sup>(1)(2)</sup>	3.2	-	
PCB	Machined <sup>(3)</sup>	-	RM20M12E8K <sup>(1)</sup>	RC20M12E84K <sup>(1)</sup>	-	-
Coaxial	Cable Multipiece	-	RMDXK10D28	RCDXK1D28	-	-
	Cable Monocrimp	-	RMDX60xxD28	RCDX60xxD28	-	-
	Twisted pair Multipiece	-	RMDXK10D28 + york090	RCDXK1D28 + york090	-	-
	Twisted pair Monocrimp	-	RMDX60xxD28	RCDX60xxD28	-	-
Fiber optic	POF contacts Plastic optical fibre	-	RMPOF1000	RCPOF1000B	-	-

(1): Example of plating, for other plating see page 143  
 (2): Loose piece contact available if putting L. Example: SM20ML1-TK6  
 (3): For dimensions see page 148

Electrical characteristics
<p><b>UL</b> 10A 500V UL94 V-0</p> <p><b>CSA</b> 7A 500V UL94 V-0</p> <p><b>IEC</b> 13A 150V 2.5kV 3</p>

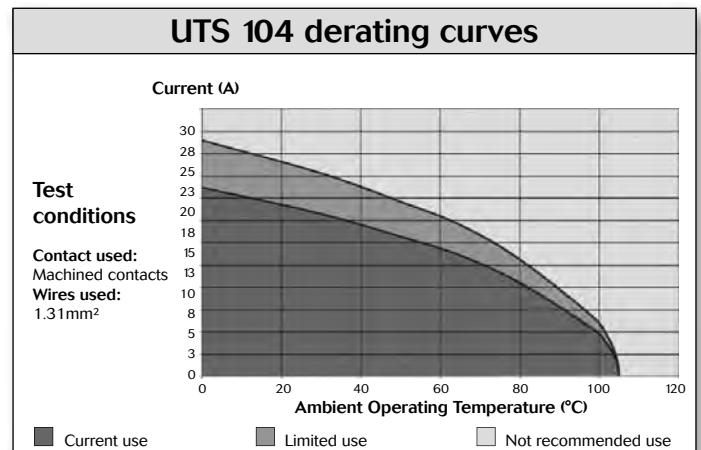



# UTS Series

## 14E5/14D5

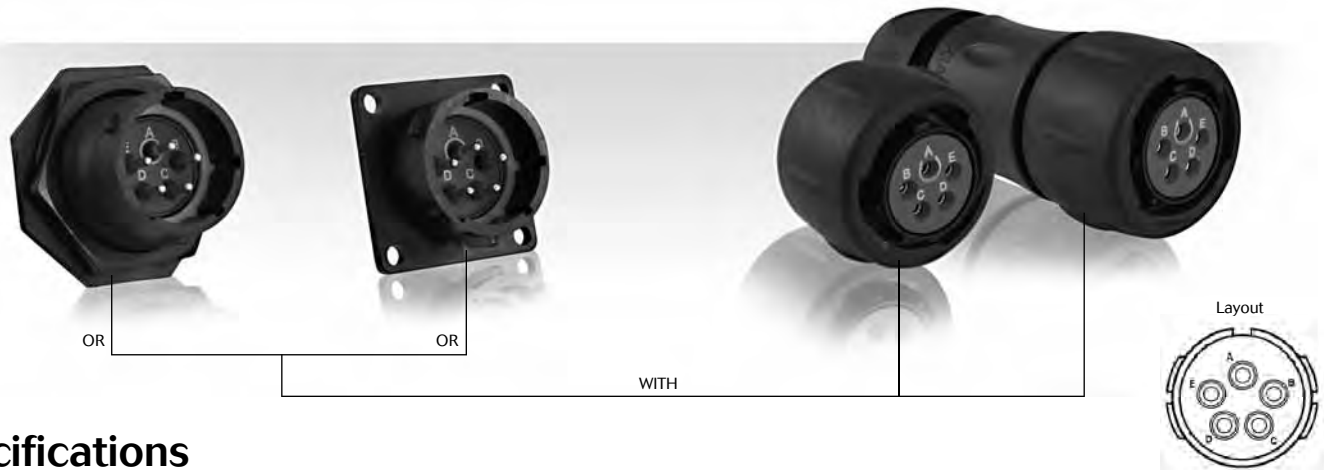

## Specifications

Contact type	Connector type	Backshell	Part number	
			Male insert	Female insert
Hand solder electrical contacts loaded	Square flange receptacle	Without (Fig.6)	UTS014E5P	UTS014E5S
	Plug	Without (Fig.1)	UTS614E5P	UTS614E5S
		Cable gland (Fig.2)	UTS6JC14E5P	UTS6JC14E5S
	Jam nut receptacle	Without (Fig.3)	UTS714E5P	UTS714E5S
PCB contacts loaded	Square flange receptacle	Without (Fig.6)	UTS014D5P	UTS014D5S
	Jam nut receptacle with hold down clips	Without (Fig.4)	UTS714D5P32	UTS714D5S32
	Jam nut receptacle with stand off and without hold down clip	Without (Fig.5)	UTS714D5P	UTS714D5S

Sealed unmated



### Dimensions

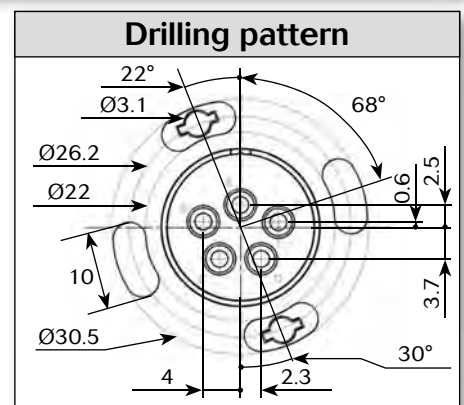
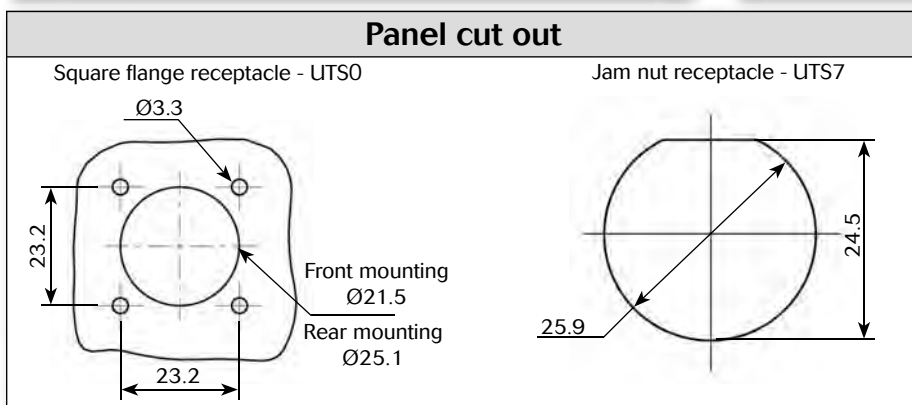
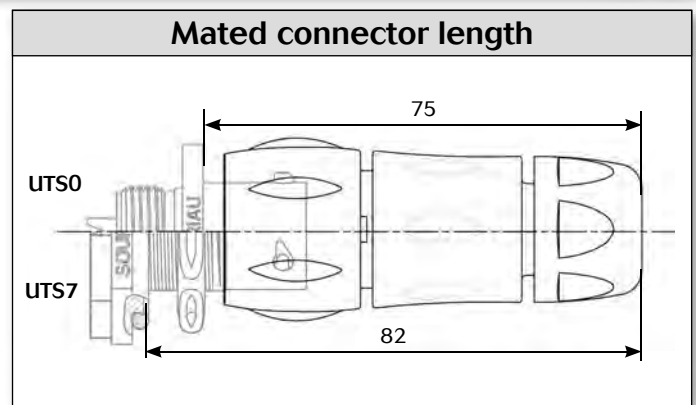
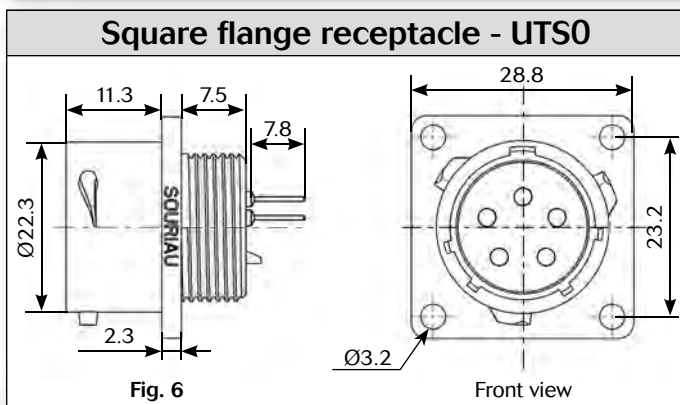
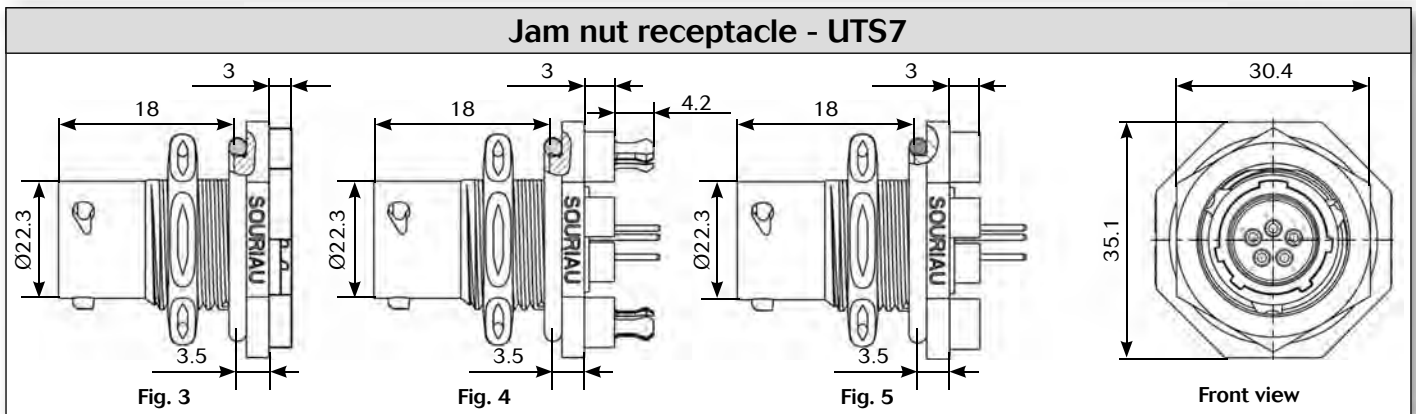
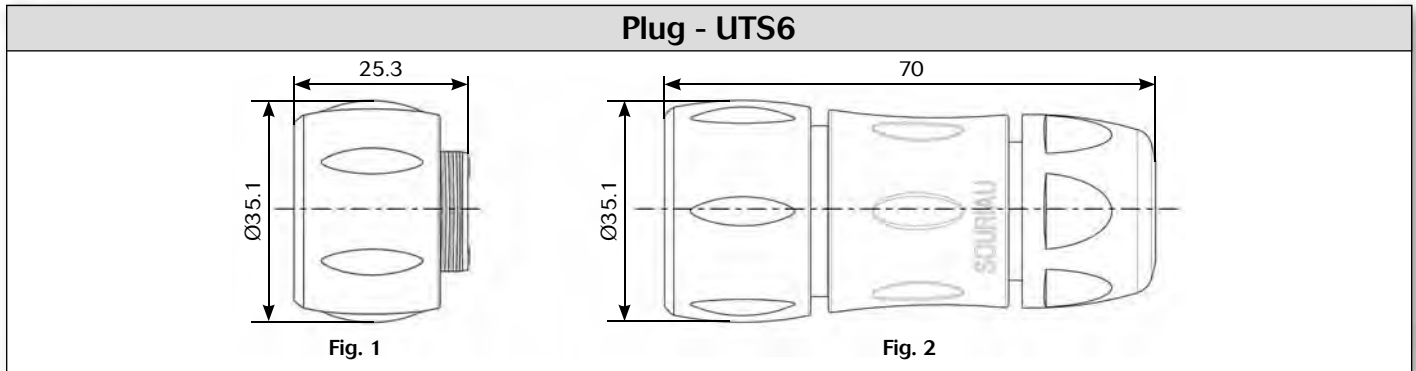

Note: all dimensions are in mm



### Accessories

#### Jam nut sealing caps

Metal terminal

Part number
UTS14DCG

Part number
UTS14DCGR

#### Plug sealing cap

Part number
UTS614DCG

#### Square flange sealing cap

Metal terminal

Part number
UTS14DCGE

#### Plastic protective cap

Part numbers	
Receptacle cap	Plug cap
85005588A	85005597

#### Gasket

Part numbers / neoprene
UTFD14B

#### Color coding rings

G for Green  
Y for Yellow  
R for Red

Part numbers	
Receptacles	Plugs
UTS714CCR	UTS614CCR
UTS714CCRY	UTS614CCRY
UTS714CCRG	UTS614CCRG

\* Add G for Green, Y for Yellow, R for Red

#### Electrical characteristics

**UL**  
12A 650V UL94 HB

**CSA**  
12A 650V UL94 HB

**IEC**  
16A 150V 2.5kV 3

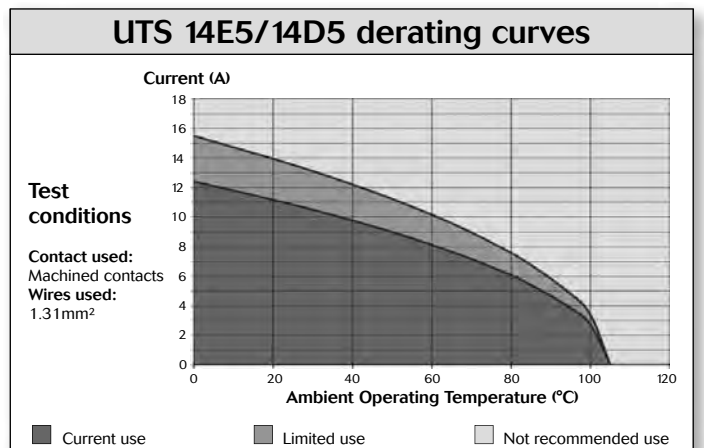

# UTS Series

14E5/14D5



# UTS Series

103W3 (3x#16 + 3x#20)

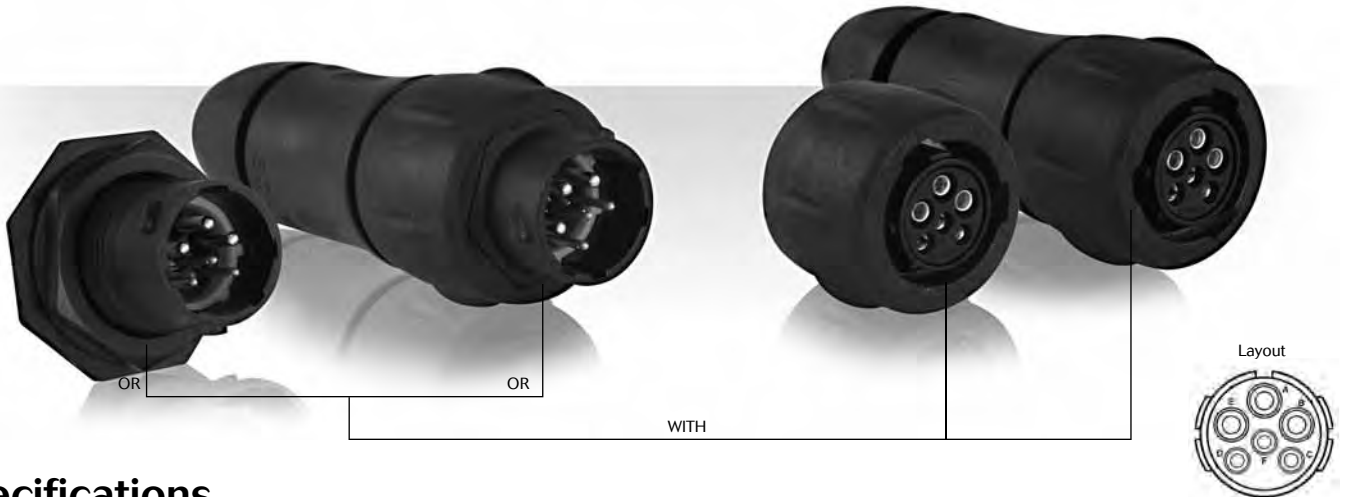

## Specifications

Contact type	Connector type	Backshell	Part number	
			Male insert	Female insert
Crimp contacts supply separately see page 79	Free hanging receptacle	Cable gland (Fig.1)	UTS1JC103W3P	UTS1JC103W3S
	Plug	Without (Fig.2)	UTS6103W3P	UTS6103W3S
	Plug	Cable gland (Fig.3)	UTS6JC103W3P	UTS6JC103W3S
	Jam nut receptacle	Without (Fig.4)	UTS7103W3P	UTS7103W3S
PCB contacts supply separately see page 79	Jam nut receptacle with stand off and without hold down clip	Without (Fig.4)	UTS7103W3P	UTS7103W3S

# UTS Series

103W3 (3x#16 + 3x#20)



6 contacts  
5A/32V  
per IEC 61984

## Dimensions

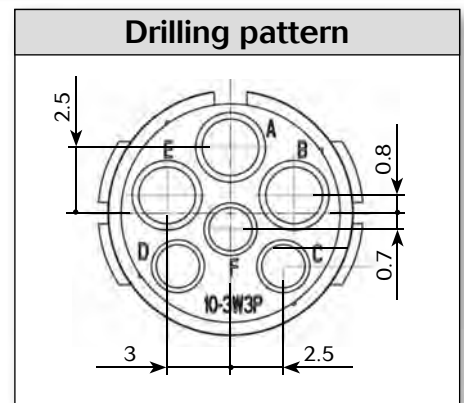
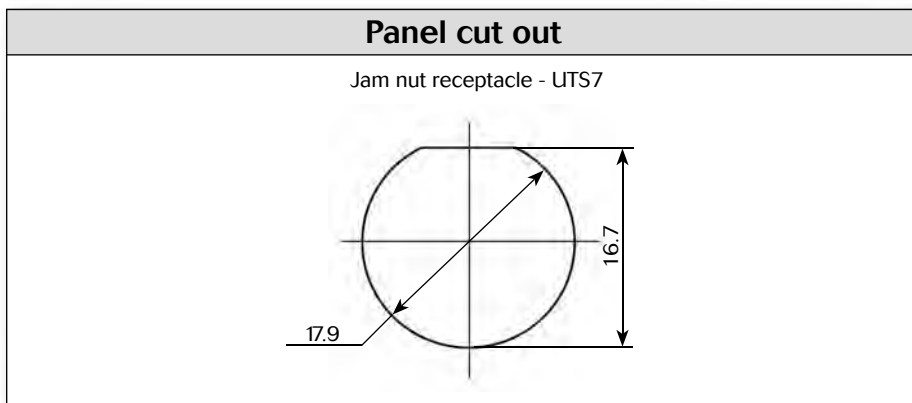
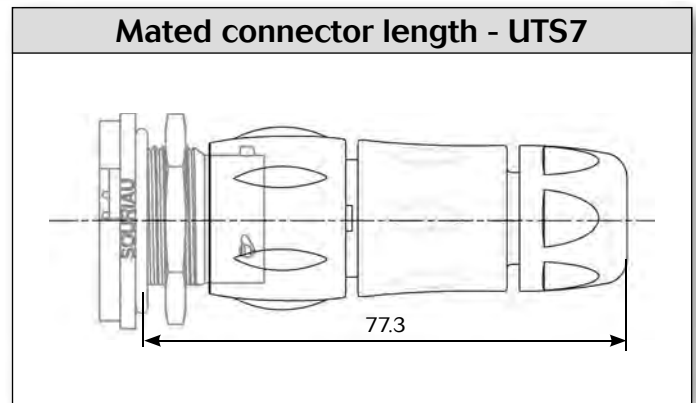
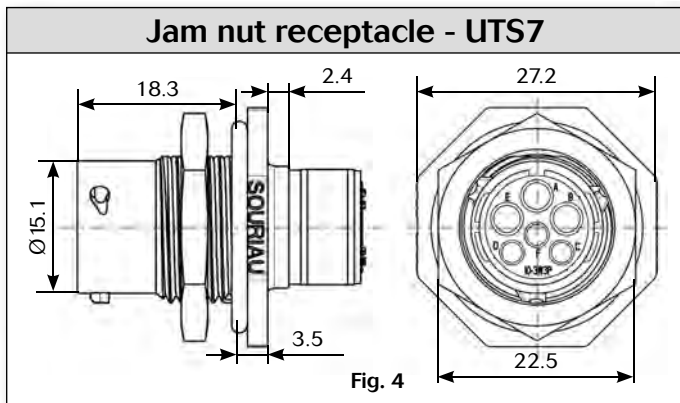
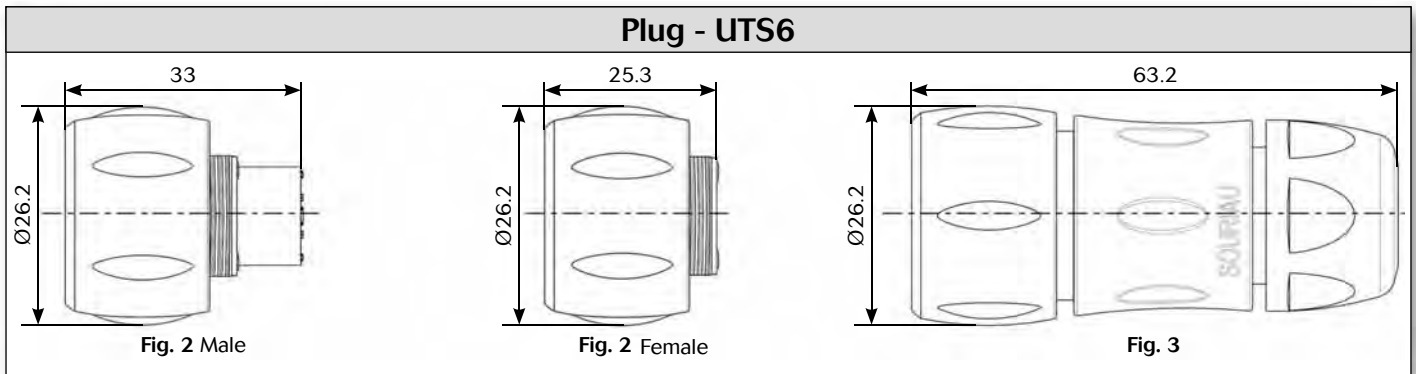
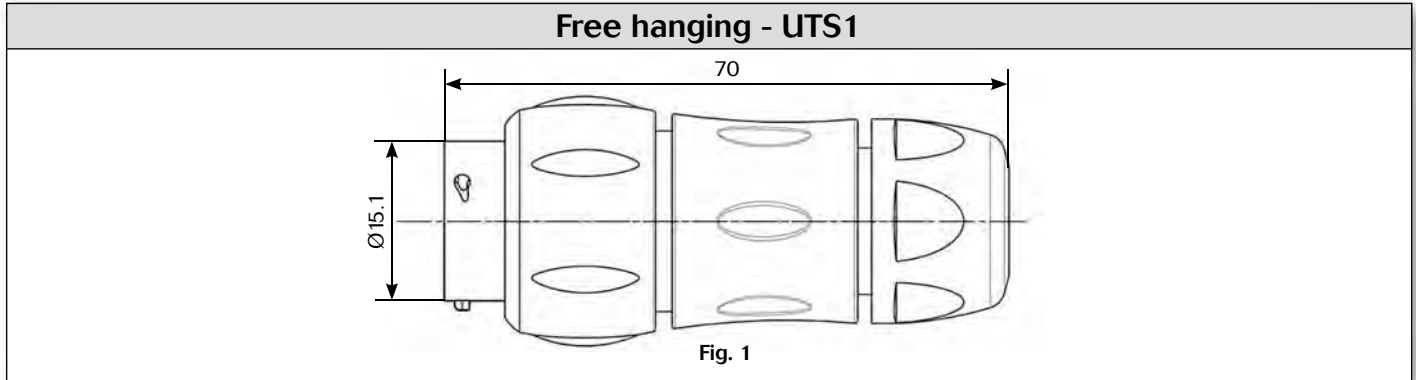



Note: all dimensions are in mm

# UTS Series

103W3 (3x#16 + 3x#20)



## Accessories and tooling

Jam nut sealing caps	
	
Part number	Part number
UTS10DCG	UTS10DCGR

Metal terminal

Handle

Part number
SHANGLES

Tool kit

Part number
TOOLKIT

Plug sealing cap

Part number
UTS610DCG



Square flange sealing cap

Part number
UTS10DCGE

Metal terminal

Plastic protective cap	
	
Part numbers	
Receptacle cap	Plug cap
85005586A	85005595

Gasket

Part numbers / neoprene
UTFD12B

Color coding rings	
G for Green	
Y for Yellow	
R for Red	
Part numbers	
Receptacles	Plugs
UTS710CCRR	UTS610CCRR
UTS710CCRY	UTS610CCRY
UTS710CCRG	UTS610CCRG

\* Add G for Green, Y for Yellow, R for Red

Crimp tooling			
Contacts	Contact size	Part number of head	
RM/RC 28M1K <sup>(1)</sup>	Standard contacts #16 Ø 1.6mm	S16RCM20	
RM/RC 24M9K <sup>(1)</sup>		S16RCM20	
RM/RC 20M13K <sup>(1)</sup>		S16RCM20	
RM/RC 20M12K <sup>(1)</sup>		S16RCM20	
RM/RC 16M23K <sup>(1)</sup>		S16RCM16	
RM/RC 14M50K <sup>(1)</sup>		S16RCM1450	
RM/RC 14M30K <sup>(1)</sup>		S16RCM14	
SM/SC 24ML1TK6 <sup>(1)</sup>		S16SCM20	
SM/SC 20ML1TK6 <sup>(1)</sup>		S16SCM20	
SM/SC 16ML1TK6 <sup>(1)</sup>		S16SCML1	
SM/SC 14ML1TK6 <sup>(1)</sup>		S16SCML1	
SM/SC 16ML11TK6 <sup>(1)</sup>		S16SCML11	
RMDXK10D28K		Coaxial contacts	M10S-1J
RCDXK1D28K			M10S-1J
RM/RC DX60xxD28K	M10S-1J		
RM/RC DXK10D28 + york090	M10S-1J		
RM/RC DX60xxD28	M10S-1J		
RM/RC 24W3K <sup>(1)</sup>	Standard contacts #20 Ø 1mm	S20RCM	
RM/RC 20W3K <sup>(1)</sup>		S20RCM	
RM/RC 18W3K <sup>(1)</sup>		S20RCM	
SM/SC 24W3S <sup>(2)</sup>		S20SCM20	
SM/SC 24WL3S <sup>(3)</sup>		S20SCM20	
SM/SC 20W3S <sup>(2)</sup>		S20SCM20	
SM/SC 20WL3S <sup>(3)</sup>		S20SCM20	

(1): example of plating, for other plating see UTS catalog page 143  
 (2): contact reeled  
 (3): loose contact

# UTS Series

103W3 (3x#16 + 3x#20)



6 contacts  
5A/32V  
per IEC 61984

## Contacts

#16	Contact type	AWG	Part number		Max wire Ø	Max insulator Ø
			Male	Female		
Crimp	Machined	30-28	RM28M1K <sup>(1)</sup>	RC28M1K <sup>(1)</sup>	0.55	1.1
		26-24	RM24M9K <sup>(1)</sup>	RC24M9K <sup>(1)</sup>	0.8	1.6
		22-20	RM20M13K <sup>(1)</sup>	RC20M13K <sup>(1)</sup>	1.18	1.8
		22-20	RM20M12K <sup>(1)</sup>	RC20M12K <sup>(1)</sup>	1.18	2.2
		20-16	RM16M23K <sup>(1)</sup>	RC16M23K <sup>(1)</sup>	1.8	3.2
		16-14	RM14M50K <sup>(1)</sup>	RC14M50K <sup>(1)</sup>	2.05	3.2
		16-14	RM14M30K <sup>(1)</sup>	RC14M30K <sup>(1)</sup>	2.28	3.2
	Stamped & formed reeled contacts	26-24	SM24M1TK6 <sup>(1)(2)</sup>	SC24M1TK6 <sup>(1)(2)</sup>	0.89-1.28	-
		22-20	SM20M1TK6 <sup>(1)(2)</sup>	SC20M1TK6 <sup>(1)(2)</sup>	1.17-2.08	-
		18-16	SM16M1TK6 <sup>(1)(2)</sup>	SC16M1TK6 <sup>(1)(2)</sup>	3.0	-
18-16		SM16M11TK6 <sup>(1)(2)</sup>	SC16M11TK6 <sup>(1)(2)</sup>	2.0-3.0	-	
14		SM14M1TK6 <sup>(1)(2)</sup>	SC14M1TK6 <sup>(1)(2)</sup>	3.2	-	
PCB	Machined <sup>(3)</sup>	-	RM20M12E8K <sup>(1)</sup>	RC20M12E84K <sup>(1)</sup>	-	-
Coaxial	Cable Multipiece	-	RMDXK10D28	RCDXK1D28	-	-
	Cable Monocrimp	-	RMDX60xxD28	RCDX60xxD28	-	-
	Twisted pair Multipiece	-	RMDXK10D28 + york090	RCDXK1D28 + york090	-	-
	Twisted pair Monocrimp	-	RMDX60xxD28	RCDX60xxD28	-	-
Fiber optic	POF contacts Plastic optical fibre	-	RMP0F1000	RCPOF1000B	-	-
#20						
Crimp	Machined	26-24	RM24W3K <sup>(1)</sup>	RC24W3K <sup>(1)</sup>	-	1.58
		22-20	RM20W3K <sup>(1)</sup>	RC20W3K <sup>(1)</sup>	-	1.58
		20-18	RM18W3K <sup>(1)</sup>	RC18W3K <sup>(1)</sup>	-	2.1
	Stamped & formed reeled contacts	26-24	SM24W3TK6 <sup>(2)</sup>	SC24W3TK6 <sup>(2)</sup>	-	0.89-1.58
		26-24	SM24W3S26 <sup>(2)</sup>	SC24W3S25 <sup>(2)</sup>	-	0.89-1.58
		22-20	SM20W3TK6 <sup>(2)</sup>	SC20W3TK6 <sup>(2)</sup>	-	1.17-2.08
		22-20	SM20W3S26 <sup>(2)</sup>	SC20W3S25 <sup>(2)</sup>	-	1.17-2.08
		PCB	Machined <sup>(3)</sup>	-	RMW5016K	RCW5016K

(1): Example of plating, for other plating see page 143 (2): Loose piece contact available if putting L. Example: SM20ML1-TK6 (3): For dimensions see page 148

### Electrical characteristics

UL  
10A 500V UL94 V-0

CSA  
7A 500V UL94 V-0

IEC  
5A 32V 1.5kV 3  
Temperature elevation: 50°C

### UTS 103W3 derating curves

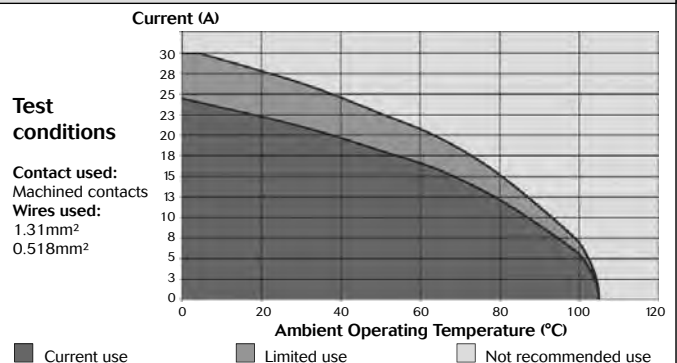



# UTS Series

## 106 - 10E6/10D6

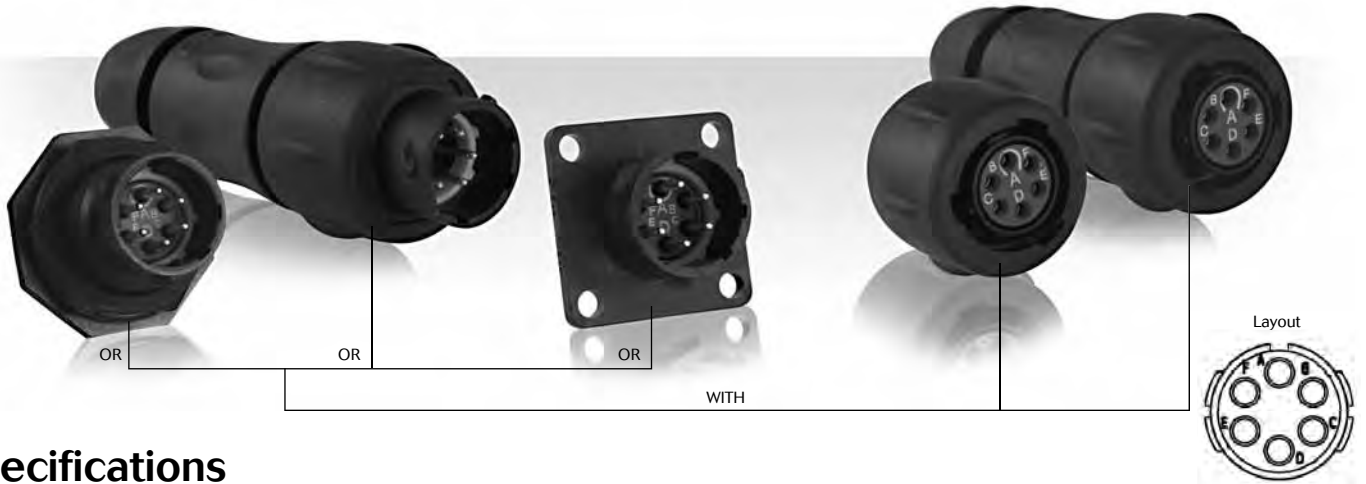

### Specifications

Contact type	Connector type	Backshell	Part number	
			Male insert	Female insert
Crimp contacts supply separately see page 83	Free hanging receptacle	Cable gland (Fig.1)	UTS1JC106P	UTS1JC106S
	Plug	Without (Fig.2)	UTS6106P	UTS6106S
	Plug	Cable gland (Fig.3)	UTS6JC106P	UTS6JC106S
	Jam nut receptacle	Without (Fig.4)	UTS7106P	UTS7106S
Hand solder electrical contacts loaded	Square flange receptacle	Without (Fig.9)	UTS010E6P	UTS010E6S
	Plug	Without (Fig.2)	UTS610E6P	UTS610E6S
		Cable gland (Fig.3)	UTS6JC10E6P	UTS6JC10E6S
	Jam nut receptacle	Without (Fig.5)	UTS710E6P	UTS710E6S
PCB contacts supply separately see page 83	Jam nut receptacle	Without (Fig.4)	UTS7106P	UTS7106S
PCB contacts loaded	Square flange receptacle	Without (Fig.8)	UTS010D6P	UTS010D6S
	Jam nut receptacle with stand off and with hold down clips	Without (Fig.6)	UTS710D6P32	UTS710D6S32
	Jam nut receptacle with stand off and without hold down clip	Without (Fig.7)	UTS710D6P	UTS710D6S

Sealed unmatred



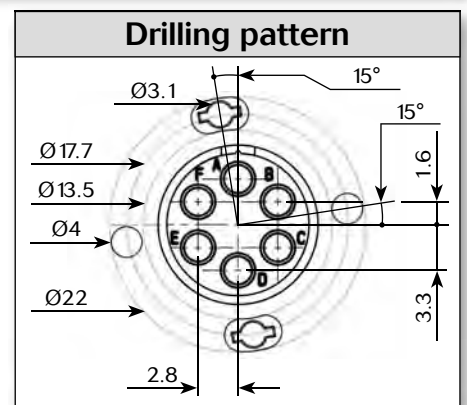
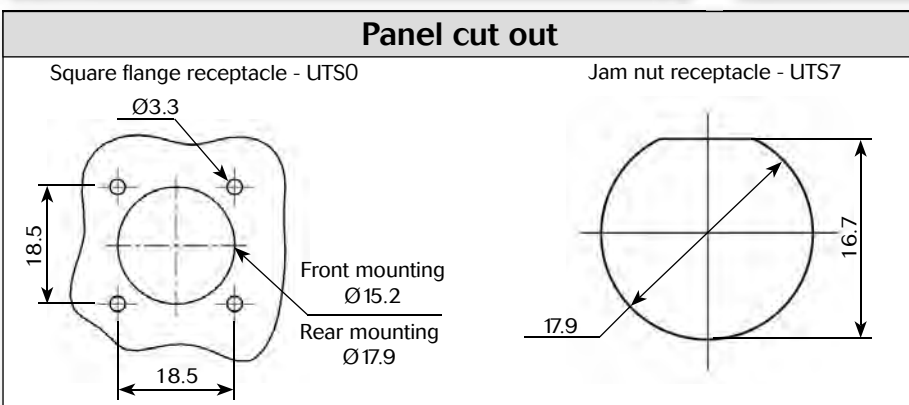
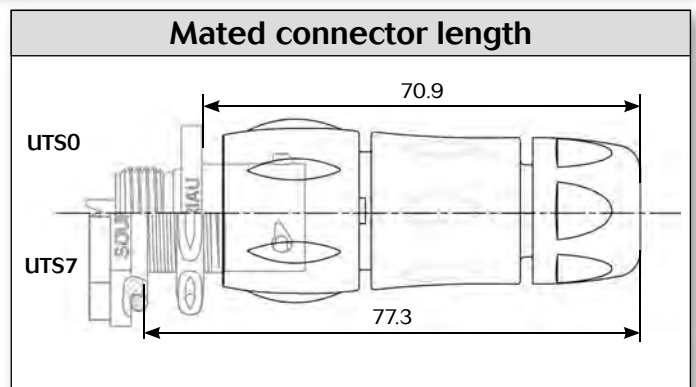
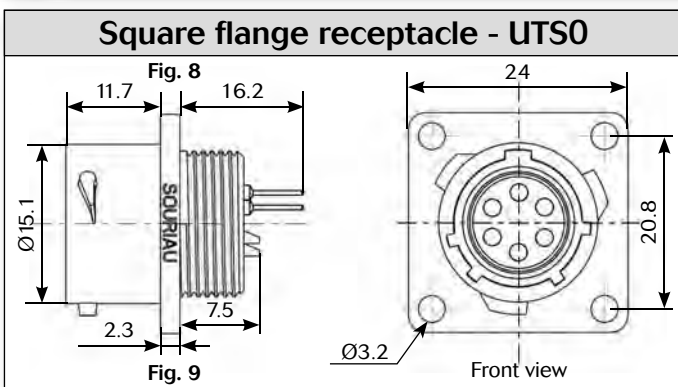
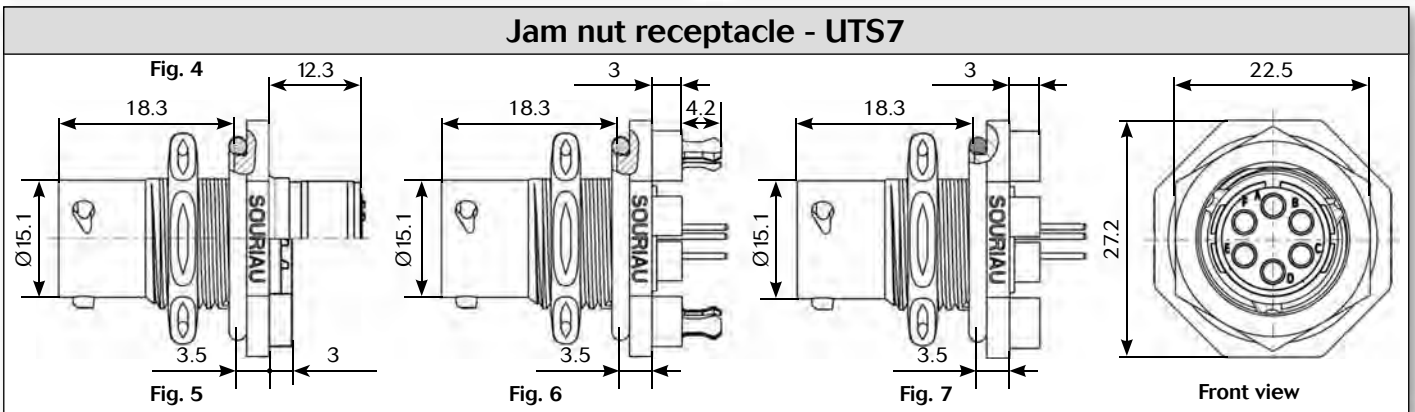
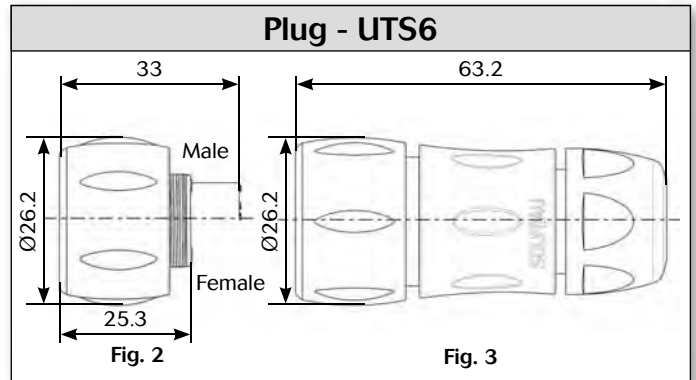
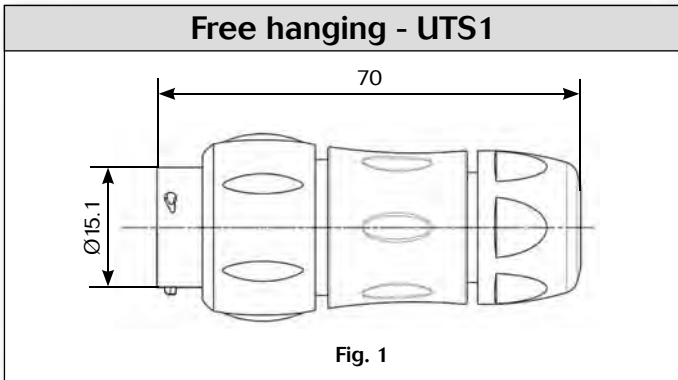

### Dimensions



Note: all dimensions are in mm



### Accessories and tooling

Jam nut sealing caps	
	
Part number	Part number
UTS10DCG	UTS10DCGR

Metal terminal

Handle

Part number
SHANGLES

Tool kit

Part number
TOOLKIT

Plug sealing cap

Part number
UTS610DCG

Square flange sealing cap

Part number
UTS10DCGE



Metal terminal

Plastic protective cap	
	
Part numbers	
Receptacle cap	Plug cap
85005586A	85005595

Gasket

Part numbers / neoprene
UTFD12B

Crimp tooling		
		
Contacts	Contact size	Part number of head
RM/RC 24W3K <sup>(1)</sup>	Standard contacts #20 Ø 1mm	S20RM
RM/RC 20W3K <sup>(1)</sup>		S20RM
RM/RC 18W3K <sup>(1)</sup>		S20RM
SM/SC 24W3S <sup>(2)</sup>		S20SCM20
SM/SC 24WL3S <sup>(3)</sup>		S20SCM20
SM/SC 20W3S <sup>(2)</sup>		S20SCM20
SM/SC 20WL3S <sup>(3)</sup>	S20SCM20	

(1): example of plating, for other plating see UTS catalog page 143  
 (2): contact reeled  
 (3): loose contact

Color coding rings	
G for Green	
Y for Yellow	
R for Red	
Part numbers	
Receptacles	Plugs
UTS710CCRR	UTS610CCRR
UTS710CCRY	UTS610CCRY
UTS710CCRG	UTS610CCRG

\* Add G for Green, Y for Yellow, R for Red

# UTS Series

## 106 - 10E6/10D6



6 contacts  
7A/32V  
per IEC 61984

### Contacts

#20	Contact type	AWG	Part number		Max wire Ø	Max insulator Ø
			Male	Female		
Crimp	Machined	26-24	RM24W3K <sup>(1)</sup>	RC24W3K <sup>(1)</sup>	-	1.58
		22-20	RM20W3K <sup>(1)</sup>	RC20W3K <sup>(1)</sup>	-	1.58
		20-18	RM18W3K <sup>(1)</sup>	RC18W3K <sup>(1)</sup>	-	2.1
	stamped & formed reeled contacts	26-24	SM24W3TK6 <sup>(2)</sup>	SC24W3TK6 <sup>(2)</sup>	-	0.89-1.58
		26-24	SM24W3TK6 <sup>(2)</sup>	SC24W3TK6 <sup>(2)</sup>	-	0.89-1.58
		22-20	SM20W3TK6 <sup>(2)</sup>	SC20W3TK6 <sup>(2)</sup>	-	1.17-2.08
		22-20	SM20W3TK6 <sup>(2)</sup>	SC20W3TK6 <sup>(2)</sup>	-	1.17-2.08
	PCB	Machined <sup>(3)</sup>	-	RMW5016K	RCW5016K	-

(1): Example of plating, for other plating see page 143  
 (2): Loose piece contact available if putting L. Example: SM20ML1-TK6  
 (3): For dimensions see page 148

Electrical characteristics	
<b>UTS 106</b> UL 5A 250V UL94 V-0  CSA 4A 250V UL94 V-0	<b>UTS 10E6/10D6</b> UL 6A 250V UL94 HB  CSA 6A 250V UL94 HB  IEC 7A 32V 1.5kV 3

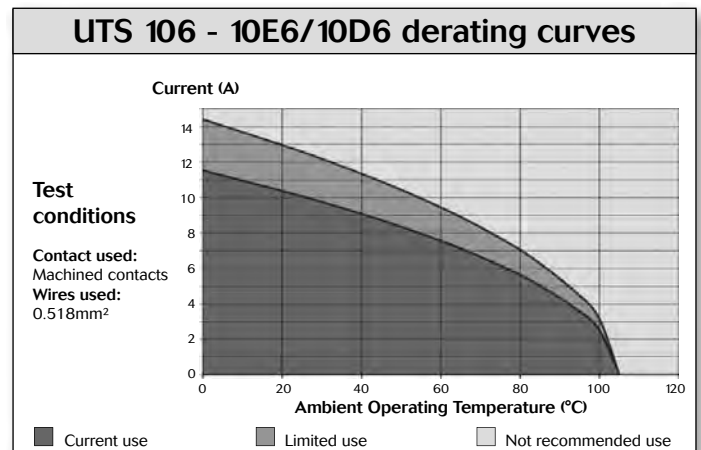

# UTS Series

## 10E98/10D98

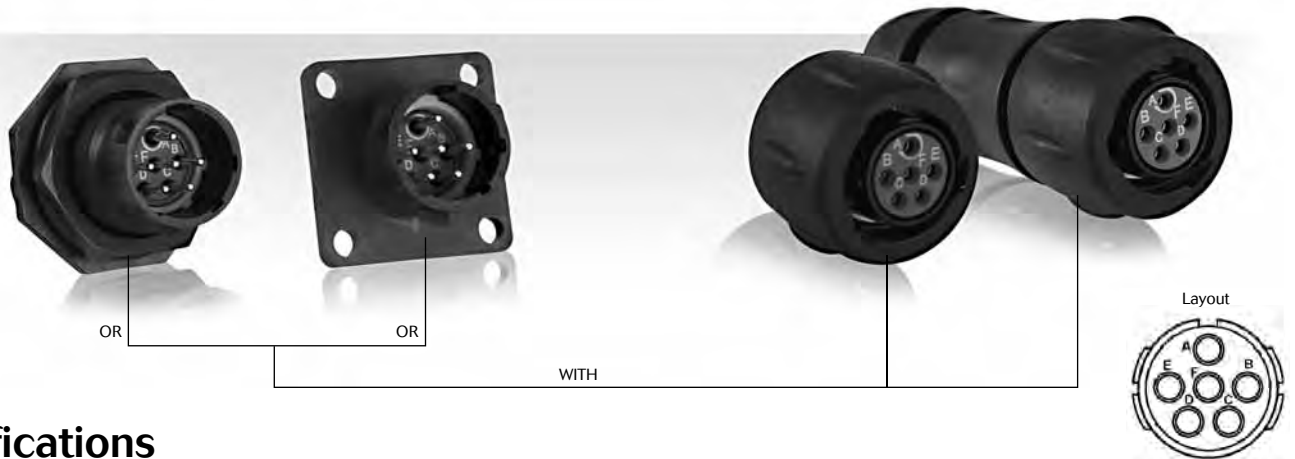

## Specifications

Contact type	Connector type	Backshell	Part number	
			Male insert	Female insert
Hand solder electrical contacts loaded	Square flange receptacle	Without (Fig.6)	UTS010E98P	UTS010E98S
	Plug	Without (Fig.1)	UTS610E98P	UTS610E98S
		Cable gland (Fig.2)	UTS6JC10E98P	UTS6JC10E98S
	Jam nut receptacle	Without (Fig.3)	UTS710E98P	UTS710E98S
PCB contacts loaded	Square flange receptacle	Without (Fig.7)	UTS010D98P	UTS010D98S
	Jam nut receptacle with stand off and with hold down clips	Without (Fig.4)	UTS710D98P32	UTS710D98S32
	Jam nut receptacle with stand off and without hold down clip	Without (Fig.5)	UTS710D98P	UTS710D98S

Sealed unsealed



### Dimensions

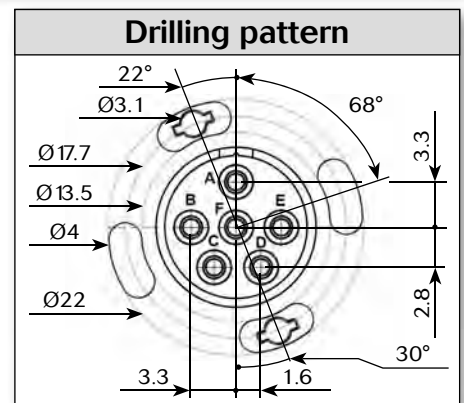
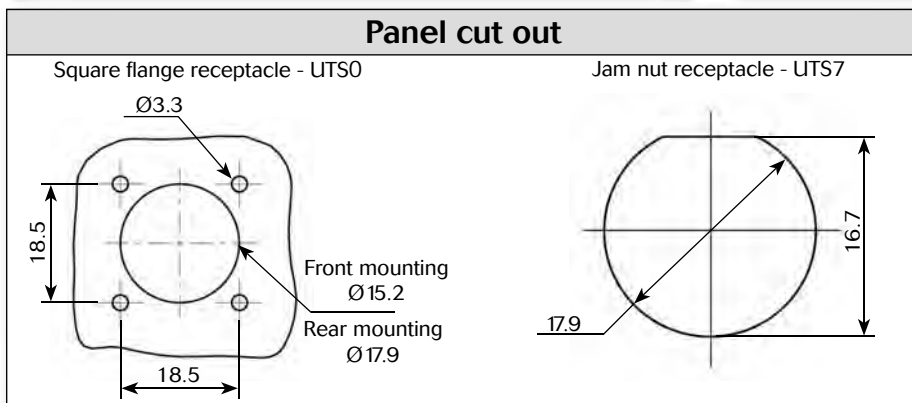
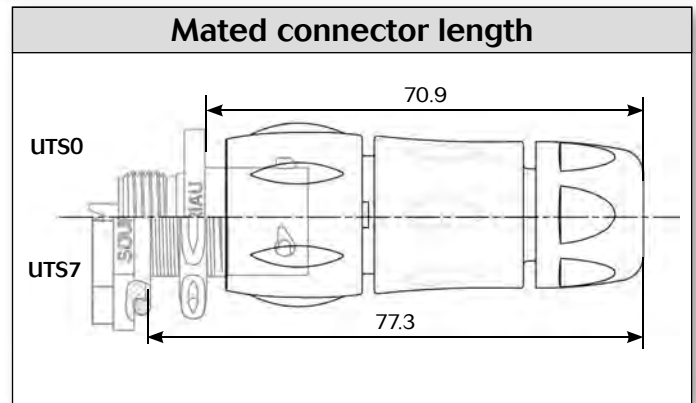
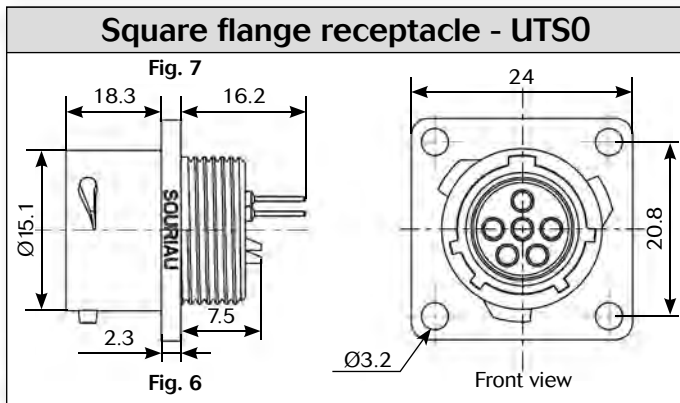
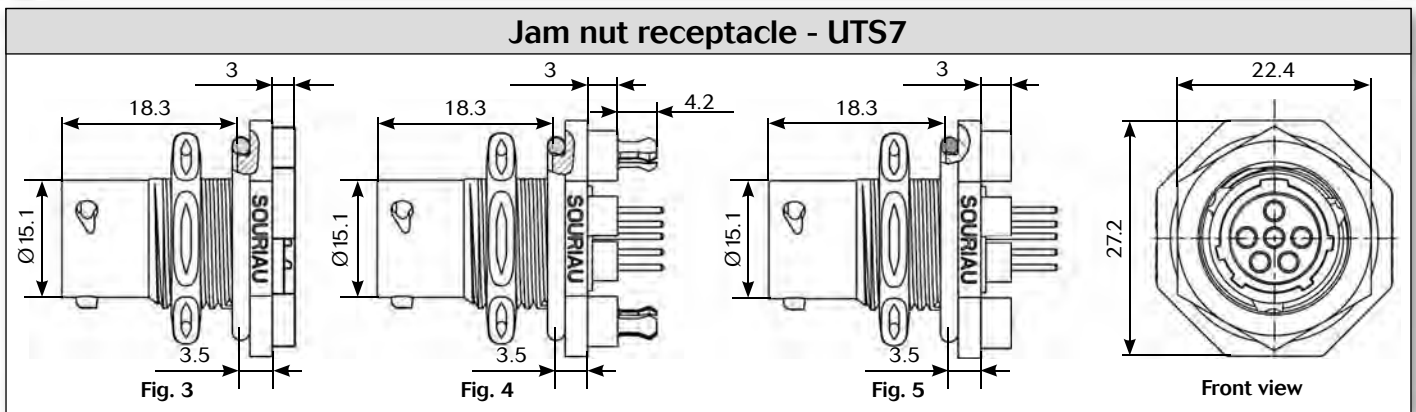
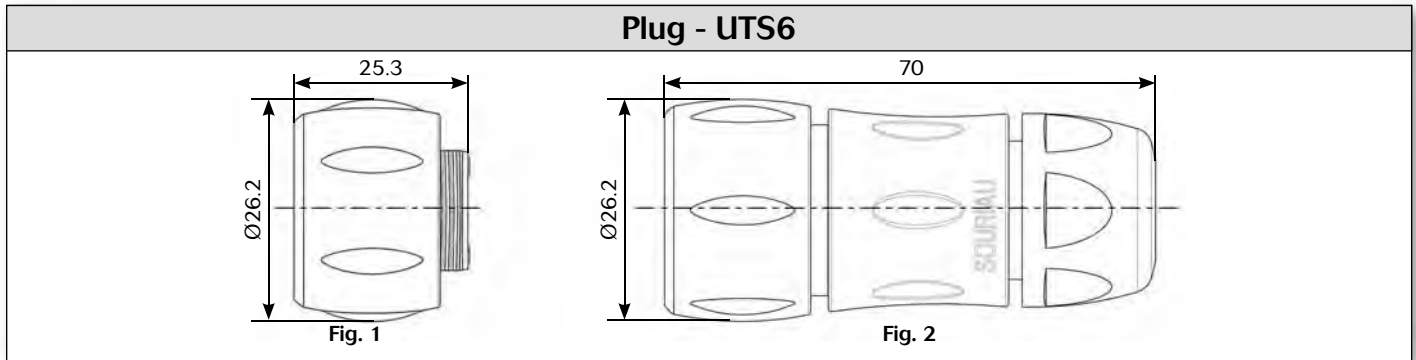

Note: all dimensions are in mm



### Accessories

#### Jam nut sealing caps

Part number	Part number
UTS10DCG	UTS10DCGR

Metal terminal

#### Plug protective cap

Part number
UTS610DCG

#### Square flange sealing cap

Part number
UTS10DCGE

Metal terminal

#### Plastic protective cap

Part numbers	
Receptacle cap	Plug cap
85005586A	85005595

#### Gasket

Part numbers / neoprene
UTFD12B

#### Color coding rings

Part numbers	
Receptacles	Plugs
UTS710CCR	UTS610CCR
UTS710CCRY	UTS610CCRY
UTS710CCRG	UTS610CCRG

\* Add G for Green, Y for Yellow, R for Red

#### Electrical characteristics

**UL**  
6A 250V UL94 HB

**CSA**  
6A 250V UL94 HB

**IEC**  
7A 50V 1.5kV 3

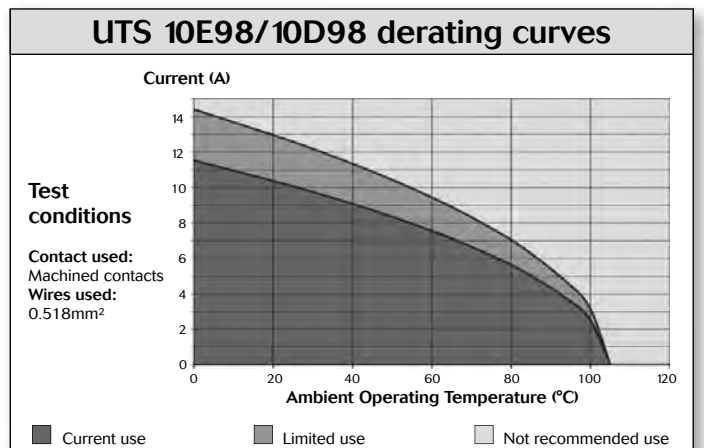

# UTS Series

10E98/10D98





# UTS Series

## 147 - 14E7/14D7

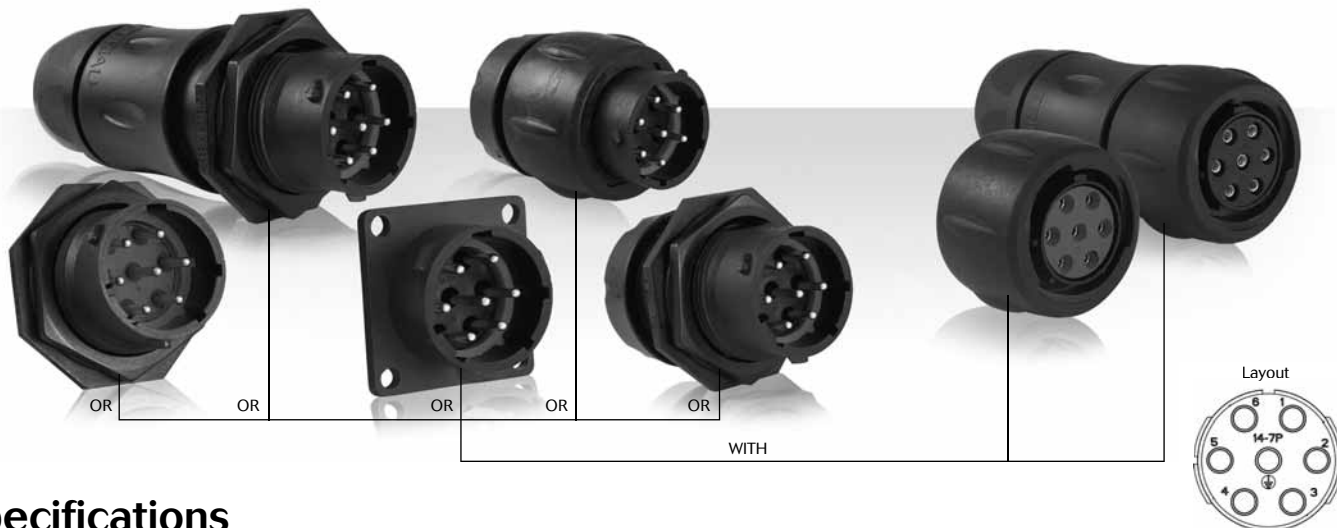

## Specifications

Contact type	Connector type	Backshell	Part number	
			Male insert	Female insert
Crimp contacts supply separately see page 91	Square flange receptacle	Without (Fig.2)	UTS0147P	
	Free hanging receptacle	Cable gland and grommet (Fig.3)	UTS1GJC147P	
	Free hanging receptacle	Nut and grommet (Fig.4)	UTS1GN147P	
	Free hanging receptacle	Cable gland (Fig.3)	UTS1JC147P	UTS1JC147S
	Plug	Without (Fig.5)	UTS6147P	UTS6147S
	Plug	Cable gland and grommet (Fig.6)		UTS6GJC147S
	Plug	Nut and grommet (Fig.7)		UTS6GN147S
	Plug	Cable gland (Fig.6)	UTS6JC147P	UTS6JC147S
	Jam nut receptacle	Without (Fig.8)	UTS7147P	UTS7147S
	Jam nut receptacle	Cable gland and grommet (Fig.10)	UTS7GJC147P	
	Jam nut receptacle	Nut and grommet (Fig.9)	UTS7GN147P	
Handsolder electrical contacts loaded	Square flange receptacle	Without (Fig.2)	UTS014E7P	UTS014E7S
	Plug	Cable gland (Fig.6)	UTS6JC14E7P	UTS6JC14E7S
	Jam nut receptacle	Without (Fig.11)	UTS714E7P	UTS714E7S
PCB contacts loaded	Square flange receptacle	Without (Fig.1)	UTS014D7P	UTS014D7S
	Jam nut receptacle with stand off and hold down clips	Without (Fig.11)	UTS714D7P32	UTS714D7S32
	Jam nut receptacle with stand off and without hold down clip	Without (Fig.11)	UTS714D7P	UTS714D7S
	Jam nut receptacle	With stand off and hold down clip (Fig.11)	UTS7147PSEK9	
Screw contacts loaded	Jam nut receptacle	Without (Fig.8)	UTS7147PSCR	UTS7147SSCR
	Free hanging receptacle	Cable gland (Fig.3)	UTS1JC147PSCR	
	Plug	Cable gland (Fig.6)	UTS6JC147PSCR	UTS6JC147SSCR

Sealed unmatred



### Dimensions

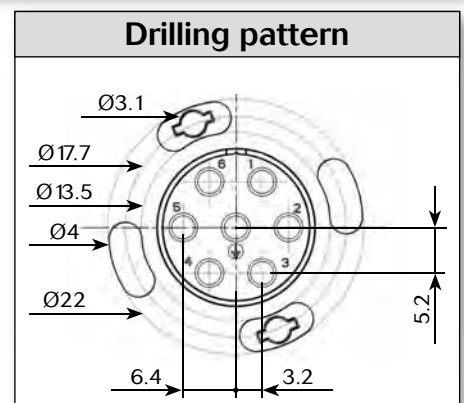
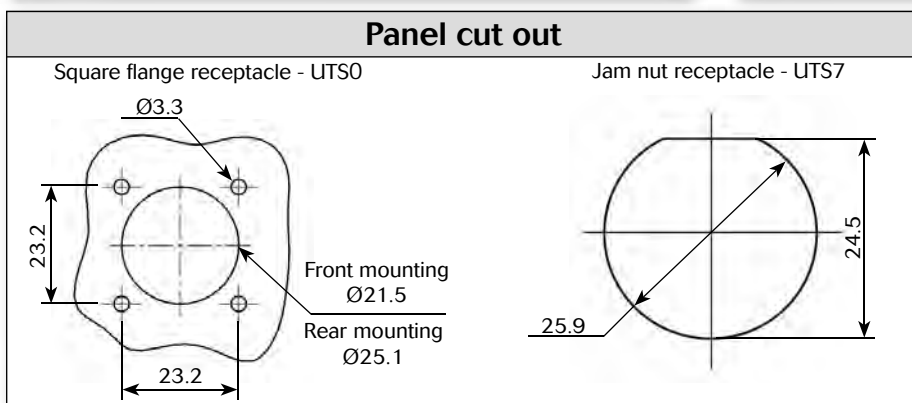
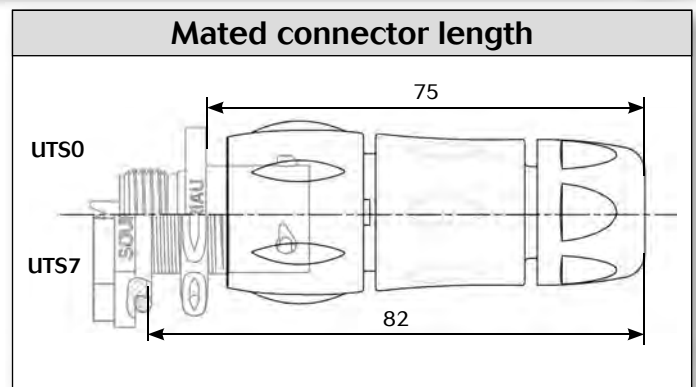
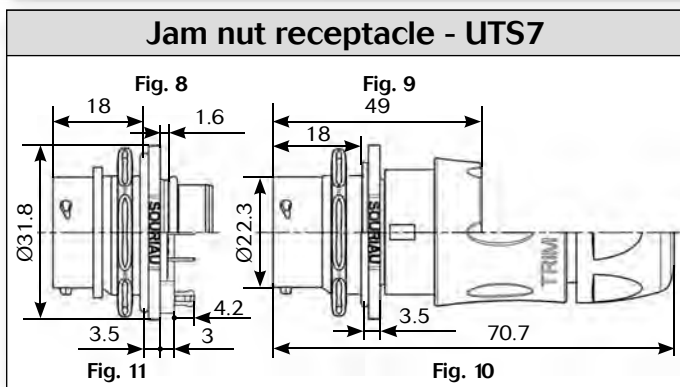
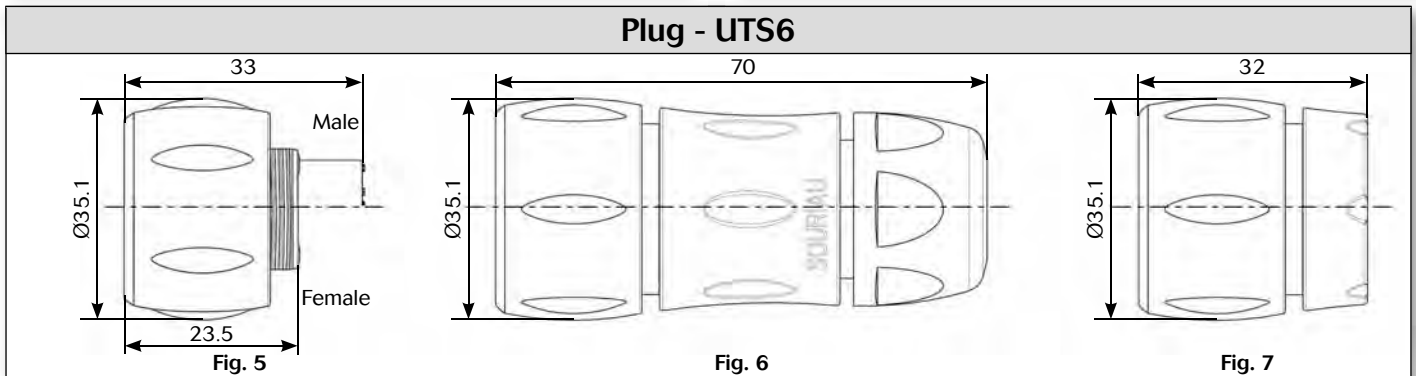
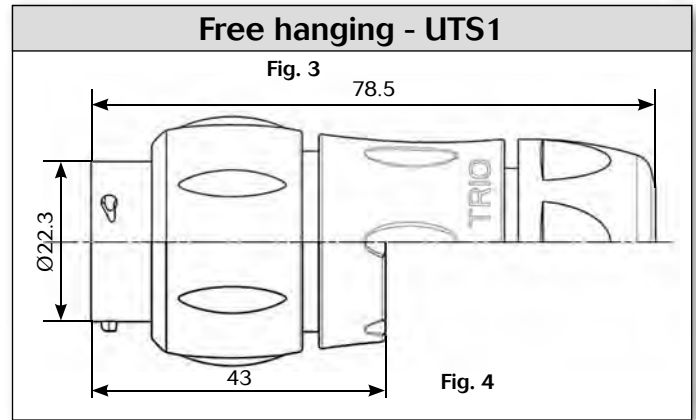
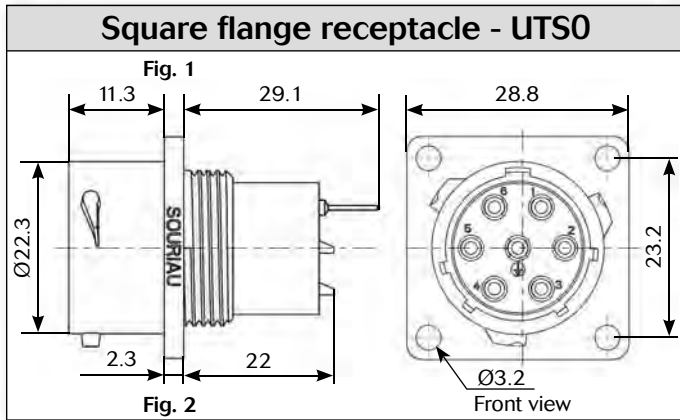

Note: all dimensions are in mm



### Accessories and tooling

Jam nut sealing caps	
	
Part number	Part number
UTS14DCG	UTS14DCGR

Metal terminal

Handle

Part number
SHANGLES

Tool kit

Part number
TOOLKIT

Plug sealing cap

Part number
UTS614DCG





Square flange sealing cap

Part number
UTS14DCGE

Metal terminal

Plastic protective cap	
	
Part numbers	
Receptacle cap	Plug cap
85005588A	85005597

Gasket

Part numbers / neoprene
UTFD14B

Color coding rings												
G for Green		<table border="1"> <thead> <tr> <th colspan="2">Part numbers</th> </tr> <tr> <th>Receptacles</th> <th>Plugs</th> </tr> </thead> <tbody> <tr> <td>UTS714CCR</td> <td>UTS614CCR</td> </tr> <tr> <td>UTS714CCRY</td> <td>UTS614CCRY</td> </tr> <tr> <td>UTS714CCRG</td> <td>UTS614CCRG</td> </tr> </tbody> </table>	Part numbers		Receptacles	Plugs	UTS714CCR	UTS614CCR	UTS714CCRY	UTS614CCRY	UTS714CCRG	UTS614CCRG
Part numbers												
Receptacles	Plugs											
UTS714CCR	UTS614CCR											
UTS714CCRY	UTS614CCRY											
UTS714CCRG	UTS614CCRG											
Y for Yellow												
R for Red												
												

\* Add G for Green, Y for Yellow, R for Red

Crimp tooling			
			
Contacts	Contact size	Part number of head	
RM/RC 28M1K <sup>(1)</sup>	Standard contacts #16 Ø 1.6mm	S16RCM20	
RM/RC 24M9K <sup>(1)</sup>		S16RCM20	
RM/RC 20M13K <sup>(1)</sup>		S16RCM20	
RM/RC 20M12K <sup>(1)</sup>		S16RCM20	
RM/RC 16M23K <sup>(1)</sup>		S16RCM16	
RM/RC 14M50K <sup>(1)</sup>		S16RCM1450	
RM/RC 14M30K <sup>(1)</sup>		S16RCM14	
SM/SC 24ML1TK6 <sup>(1)</sup>		S16SCM20	
SM/SC 20ML1TK6 <sup>(1)</sup>		S16SCM20	
SM/SC 16ML1TK6 <sup>(1)</sup>		S16SCML1	
SM/SC 14ML1TK6 <sup>(1)</sup>		S16SCML1	
SM/SC 16ML11TK6 <sup>(1)</sup>		S16SCML11	
RMDXK10D28K		Coaxial contacts	M10S-1J
RCDXK1D28K			M10S-1J
RM/RC DX60xxD28K	M10S-1J		
RM/RC DXK10D28 + york090	M10S-1J		
RM/RC DX60xxD28		M10S-1J	

(1): example of plating, for other plating see UTS catalog page 143



### Contacts

#16	Contact type	AWG	Part number		Max wire Ø	Max insulator Ø
			Male	Female		
Crimp	Machined	30-28	RM28M1K <sup>(1)</sup>	RC28M1K <sup>(1)</sup>	0.55	1.1
		26-24	RM24M9K <sup>(1)</sup>	RC24M9K <sup>(1)</sup>	0.8	1.6
		22-20	RM20M13K <sup>(1)</sup>	RC20M13K <sup>(1)</sup>	1.18	1.8
		22-20	RM20M12K <sup>(1)</sup>	RC20M12K <sup>(1)</sup>	1.18	2.2
		20-16	RM16M23K <sup>(1)</sup>	RC16M23K <sup>(1)</sup>	1.8	3.2
		16-14	RM14M50K <sup>(1)</sup>	RC14M50K <sup>(1)</sup>	2.05	3.2
		16-14	RM14M30K <sup>(1)</sup>	RC14M30K <sup>(1)</sup>	2.28	3.2
	Stamped & formed reeled contacts	26-24	SM24M1TK6 <sup>(1)(2)</sup>	SC24M1TK6 <sup>(1)(2)</sup>	0.89-1.28	-
		22-20	SM20M1TK6 <sup>(1)(2)</sup>	SC20M1TK6 <sup>(1)(2)</sup>	1.17-2.08	-
		18-16	SM16M1TK6 <sup>(1)(2)</sup>	SC16M1TK6 <sup>(1)(2)</sup>	3.0	-
18-16		SM16M11TK6 <sup>(1)(2)</sup>	SC16M11TK6 <sup>(1)(2)</sup>	2.0-3.0	-	
14		SM14M1TK6 <sup>(1)(2)</sup>	SC14M1TK6 <sup>(1)(2)</sup>	3.2	-	
PCB	Machined <sup>(3)</sup>	-	RM20M12E8K <sup>(1)</sup>	RC20M12E84K <sup>(1)</sup>	-	-
Coaxial	Cable Multipiece	-	RMDXK10D28	RCDXK1D28	-	-
	Cable Monocrimp	-	RMDX60xxD28	RCDX60xxD28	-	-
	Twisted pair Multipiece	-	RMDXK10D28 + york090	RCDXK1D28 + york090	-	-
	Twisted pair Monocrimp	-	RMDX60xxD28	RCDX60xxD28	-	-
Fiber optic	POF contacts Plastic optical fibre	-	RMPOF1000	RCPOF1000B	-	-

(1): Example of plating, for other plating see page 143  
 (2): Loose piece contact available if putting L. Example: SM20ML1-TK6  
 (3): For dimensions see page 148

Electrical characteristics
<p><b>UL</b> 10A 500V UL94 V-0</p> <p><b>CSA</b> 7A 500V UL94 V-0</p> <p><b>IEC</b> 16A 300V 4kV 3 Temperature elevation: 50°C</p>

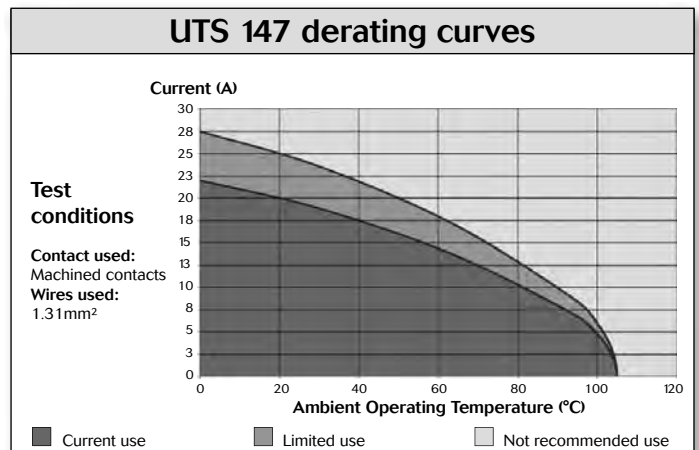

# UTS Series

## 10E7/10D7

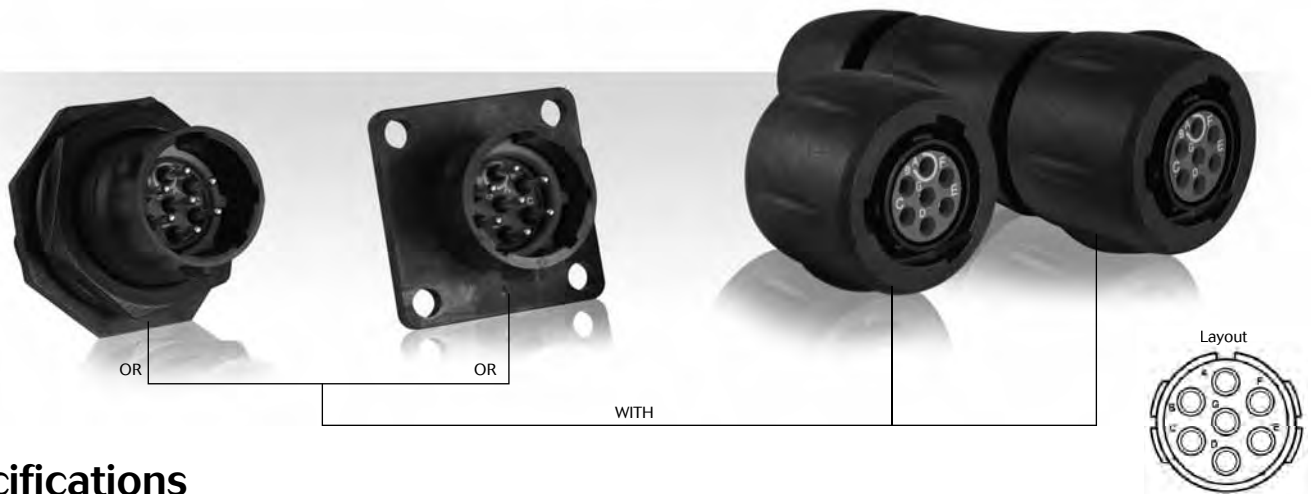

## Specifications

Contact type	Connector type	Backshell	Part number	
			Male insert	Female insert
Hand solder electrical contacts loaded	Square flange receptacle	Without (Fig.6)	UTS010E7P	UTS010E7S
	Plug	Without (Fig.1)	UTS610E7P	UTS610E7S
		Cable gland (Fig.2)	UTS6JC10E7P	UTS6JC10E7S
	Jam nut receptacle	Without (Fig.3)	UTS710E7P	UTS710E7S
PCB contacts loaded	Square flange receptacle	Without (Fig.7)	UTS010D7P	UTS010D7S
	Jam nut receptacle with stand off and with hold down clips	Without (Fig.4)	UTS710D7P32	UTS710D7S32
	Jam nut receptacle with stand off and without hold down clip	Without (Fig.5)	UTS710D7P	UTS710D7S

Sealed unmated



### Dimensions

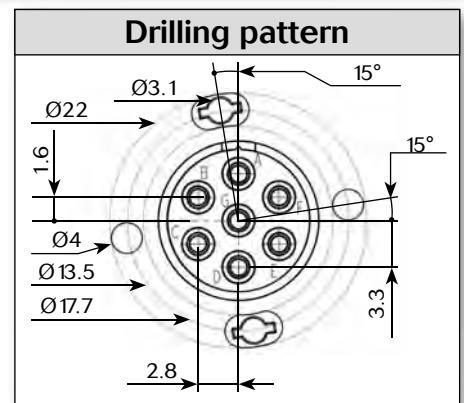
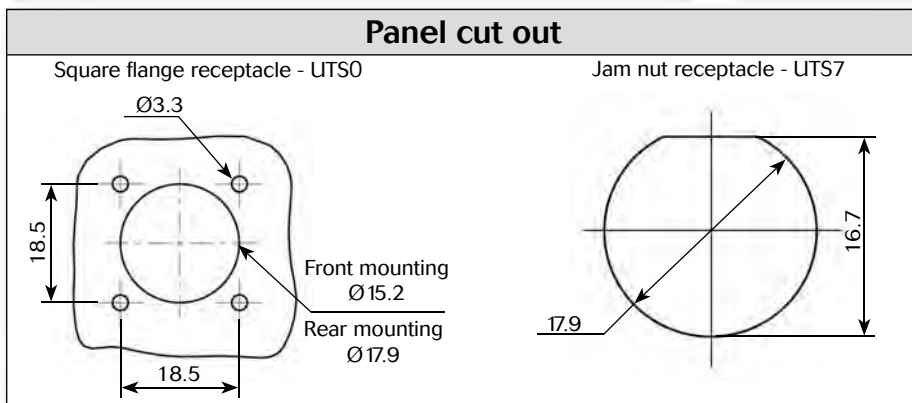
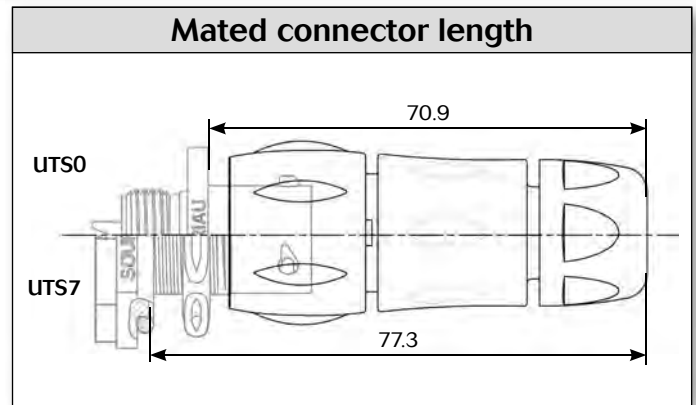
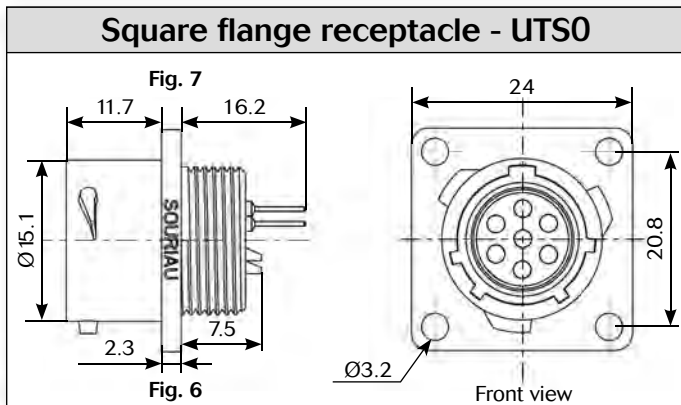
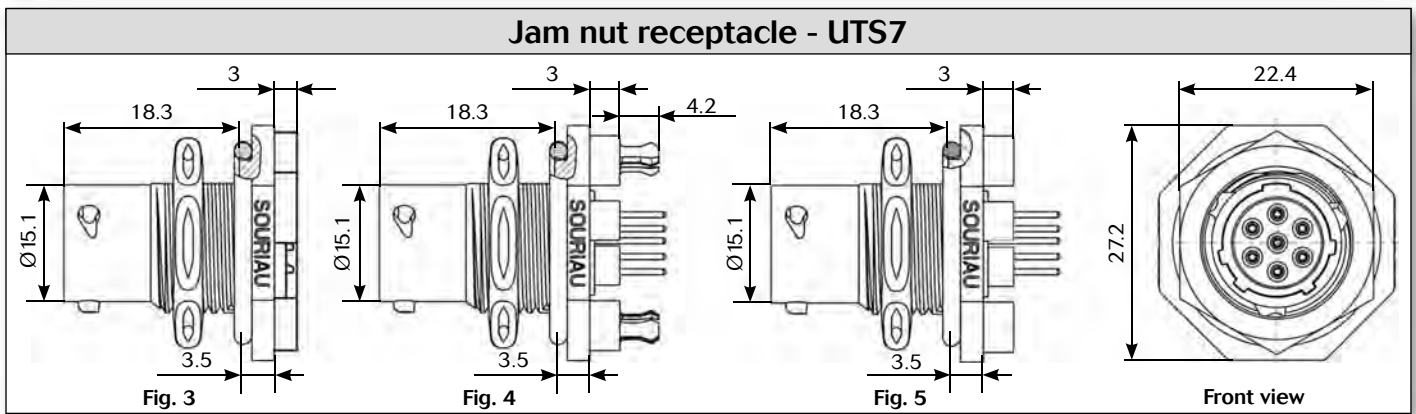
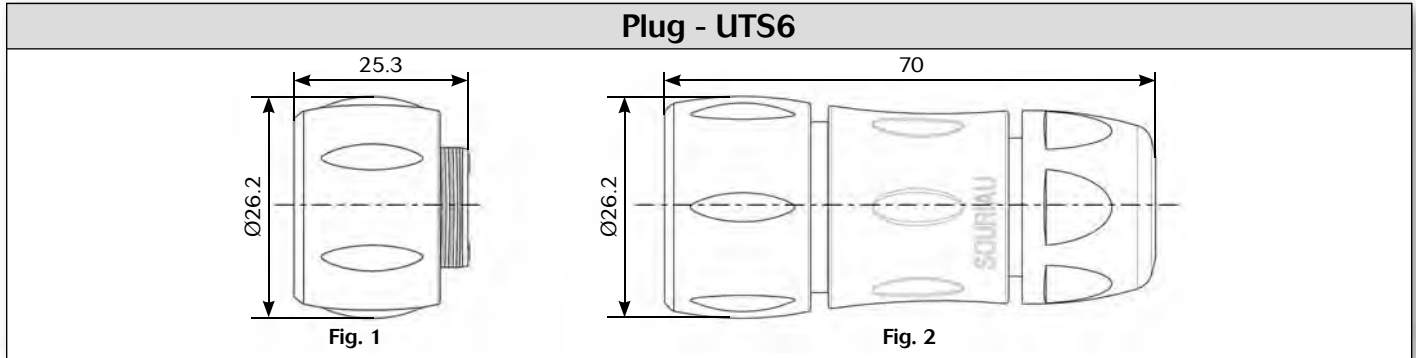

Note: all dimensions are in mm



### Accessories

#### Jam nut sealing caps

Metal terminal

Part number
UTS10DCG

Part number
UTS10DCGR

#### Plug sealing cap

Part number
UTS610DCG

#### Square flange sealing cap

Metal terminal

Part number
UTS10DCGE

#### Plastic protective cap

Part numbers	
Receptacle cap	Plug cap
85005586A	85005595

#### Gasket

Part numbers / neoprene
UTFD12B

#### Color coding rings

G for Green  
Y for Yellow  
R for Red

Part numbers	
Receptacles	Plugs
UTS710CCR	UTS610CCR
UTS710CCRY	UTS610CCRY
UTS710CCRG	UTS610CCRG

\* Add G for Green, Y for Yellow, R for Red

#### Electrical characteristics

**UL**  
6A 250V UL94 HB

**CSA**  
6A 250V UL94 HB

**IEC**  
7A 50V 1.5kV 3

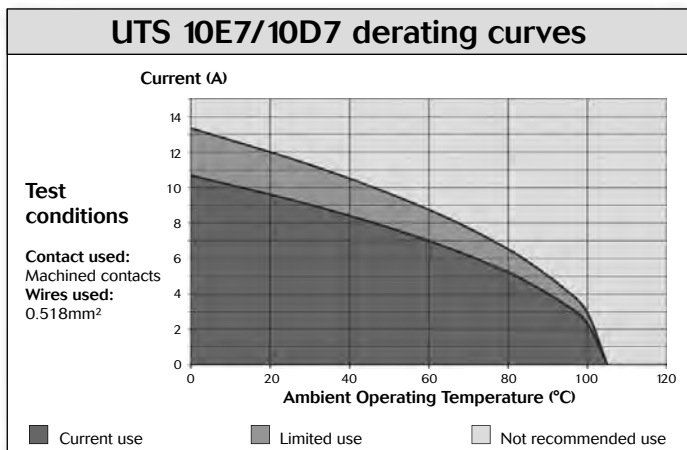

UTS Series  
10E7/10D7





# UTS Series

## 128

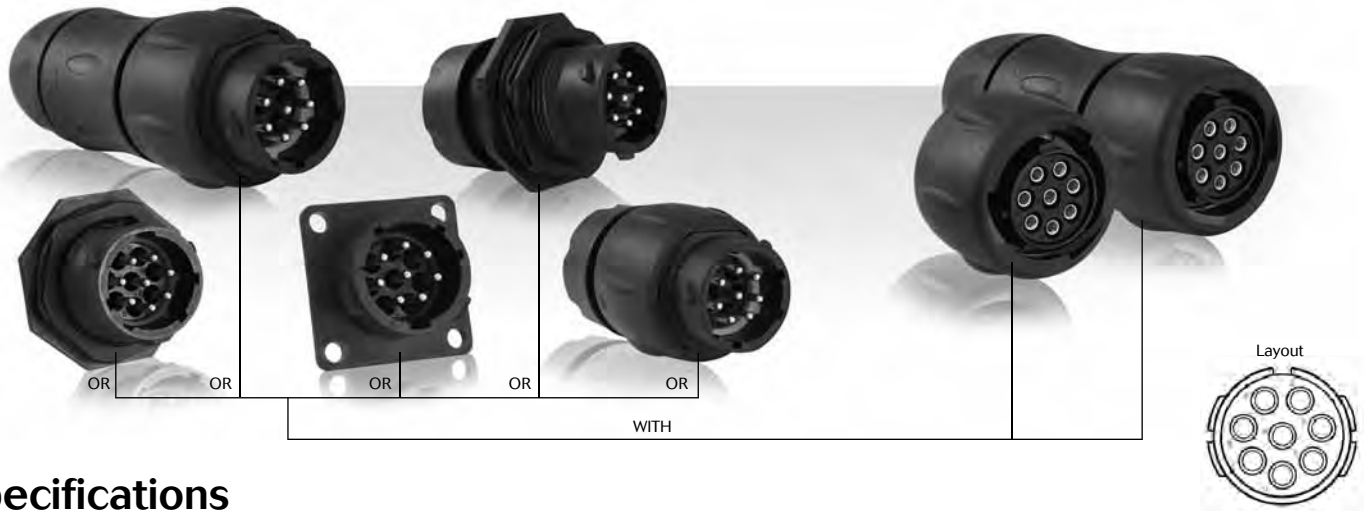

## Specifications

Contact type	Connector type	Backshell	Part number	
			Male insert	Female insert
Crimp contacts supply separately see page 99	Square flange receptacle	Without (Fig.1)	UTS0128P	UTS0128S
	Free hanging receptacle	Cable gland and grommet (Fig.2)	UTS1GJC128P	
	Free hanging receptacle	Nut and grommet (Fig.3)	UTS1GN128P	
	Free hanging receptacle	Cable gland (Fig.2)	UTS1JC128P	UTS1JC128S
	Plug	Without (Fig.4)	UTS6128P	UTS6128S
	Plug	Cable gland and grommet (Fig.5)		UTS6GJC128S
	Plug	Nut and grommet (Fig.6)		UTS6GN128S
	Plug	Cable gland (Fig.5)	UTS6JC128P	UTS6JC128S
	Jam nut receptacle	Without (Fig.8)	UTS7128P	UTS7128S
	Jam nut receptacle	Cable gland and grommet (Fig.10)	UTS7GJC128P	
	Jam nut receptacle	Nut and grommet (Fig.9)	UTS7GN128P	
PCB contacts loaded	Jam nut receptacle	With stand off and hold down clip (Fig.11)	UTS7128PSEK9	



### Dimensions

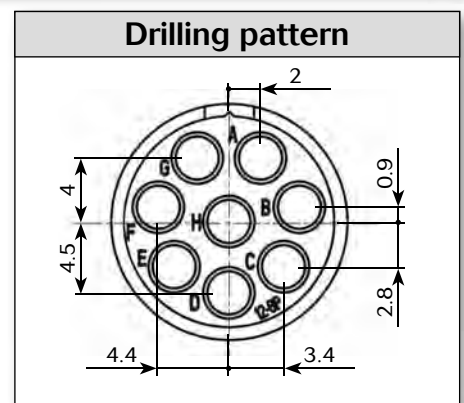
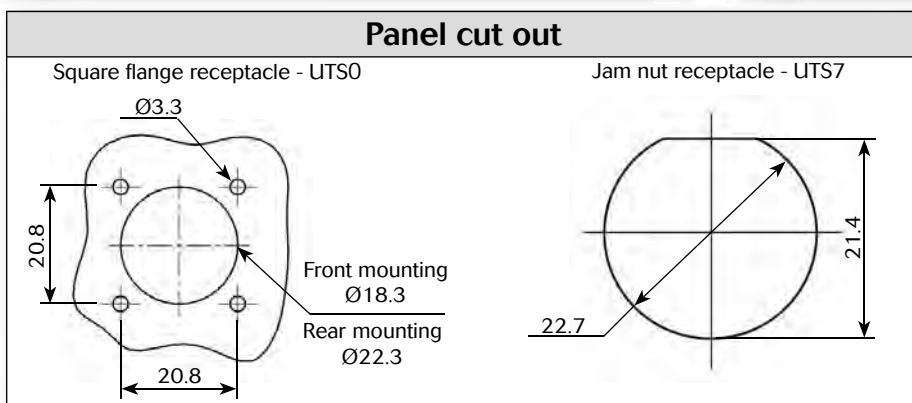
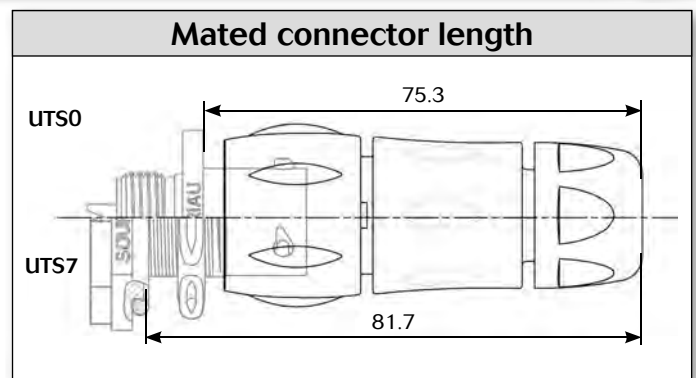
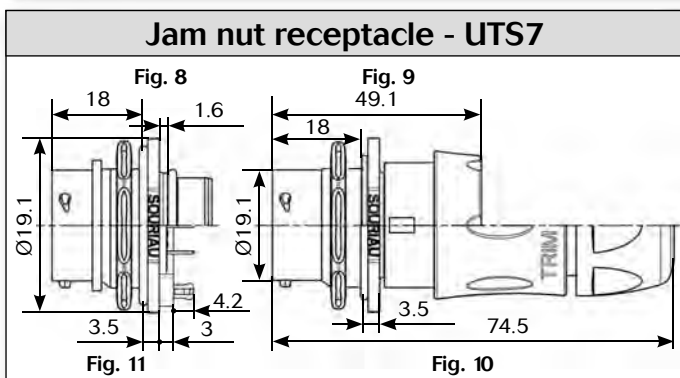
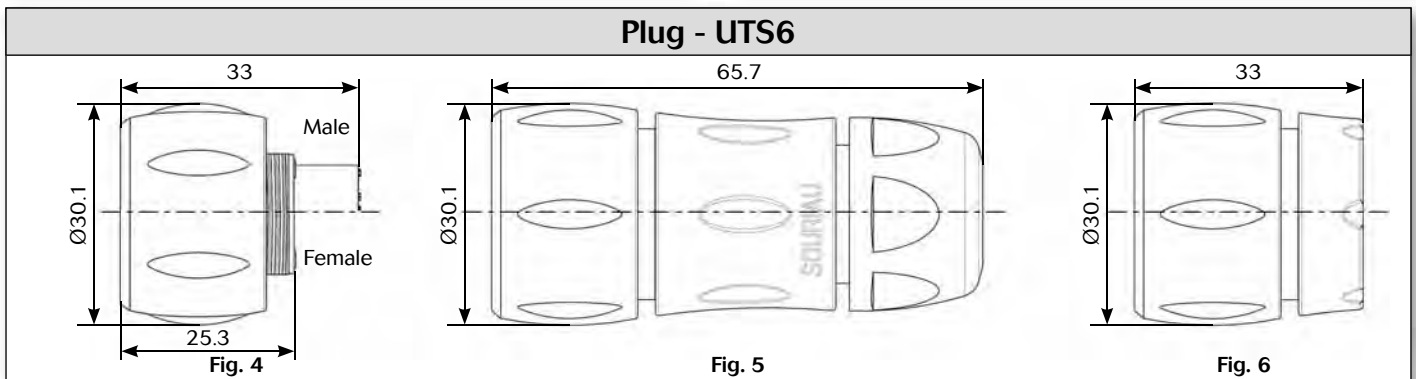
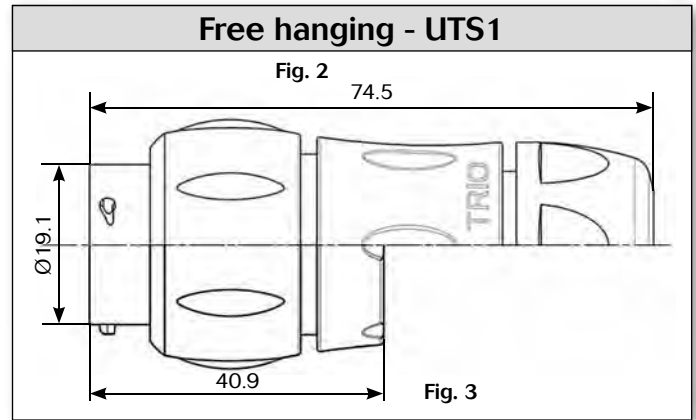
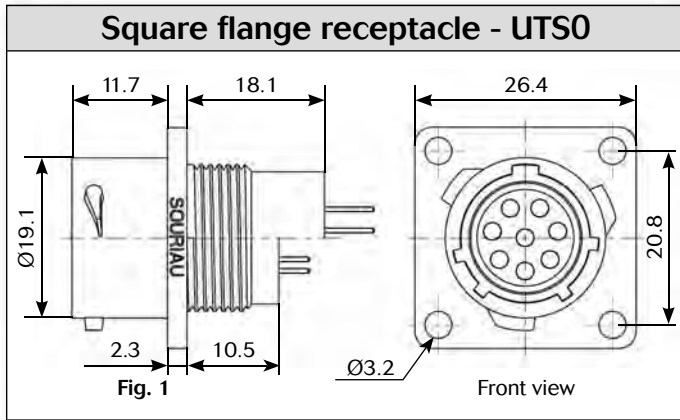



### Accessories and tooling

Jam nut sealing caps	
	
Part number	Part number
UTS12DCG	UTS12DCGR

Metal terminal

Handle

Part number
SHANDLES

Tool kit

Part number
TOOLKIT

Plug sealing cap

Part number
UTS612DCG





Square flange sealing cap

Part number
UTS12DCGE

Metal terminal

Plastic protective cap	
	
Part numbers	
Receptacle cap	Plug cap
85005587A	85005596

Gasket

Part numbers / neoprene
UTFD13B

Color coding rings												
G for Green		<table border="1"> <thead> <tr> <th colspan="2">Part numbers</th> </tr> <tr> <th>Receptacles</th> <th>Plugs</th> </tr> </thead> <tbody> <tr> <td>UTS712CCRR</td> <td>UTS612CCRR</td> </tr> <tr> <td>UTS712CCRY</td> <td>UTS612CCRY</td> </tr> <tr> <td>UTS712CCRG</td> <td>UTS612CCRG</td> </tr> </tbody> </table>	Part numbers		Receptacles	Plugs	UTS712CCRR	UTS612CCRR	UTS712CCRY	UTS612CCRY	UTS712CCRG	UTS612CCRG
Part numbers												
Receptacles	Plugs											
UTS712CCRR	UTS612CCRR											
UTS712CCRY	UTS612CCRY											
UTS712CCRG	UTS612CCRG											
Y for Yellow												
												
R for Red												

\* Add G for Green, Y for Yellow, R for Red

Crimp tooling			
			
Contacts	Contact size	Part number of head	
RM/RC 28M1K <sup>(1)</sup>	Standard contacts #16 Ø 1.6mm	S16RCM20	
RM/RC 24M9K <sup>(1)</sup>		S16RCM20	
RM/RC 20M13K <sup>(1)</sup>		S16RCM20	
RM/RC 20M12K <sup>(1)</sup>		S16RCM20	
RM/RC 16M23K <sup>(1)</sup>		S16RCM16	
RM/RC 14M50K <sup>(1)</sup>		S16RCM1450	
RM/RC 14M30K <sup>(1)</sup>		S16RCM14	
SM/SC 24ML1TK6 <sup>(1)</sup>		S16SCM20	
SM/SC 20ML1TK6 <sup>(1)</sup>		S16SCM20	
SM/SC 16ML1TK6 <sup>(1)</sup>		S16SCML1	
SM/SC 14ML1TK6 <sup>(1)</sup>		S16SCML1	
SM/SC 16ML1TK6 <sup>(1)</sup>		S16SCML11	
RMDXK10D28K		Coaxial contacts	M10S-1J
RCDXK1D28K			M10S-1J
RM/RC DX60xxD28K			M10S-1J
RM/RC DXK10D28 + york090	M10S-1J		
RM/RC DX60xxD28		M10S-1J	

(1): example of plating, for other plating see UTS catalog page 143



### Contacts

#16	Contact type	AWG	Part number		Max wire Ø	Max insulator Ø
			Male	Female		
Crimp	Machined	30-28	RM28M1K <sup>(1)</sup>	RC28M1K <sup>(1)</sup>	0.55	1.1
		26-24	RM24M9K <sup>(1)</sup>	RC24M9K <sup>(1)</sup>	0.8	1.6
		22-20	RM20M13K <sup>(1)</sup>	RC20M13K <sup>(1)</sup>	1.18	1.8
		22-20	RM20M12K <sup>(1)</sup>	RC20M12K <sup>(1)</sup>	1.18	2.2
		20-16	RM16M23K <sup>(1)</sup>	RC16M23K <sup>(1)</sup>	1.8	3.2
		16-14	RM14M50K <sup>(1)</sup>	RC14M50K <sup>(1)</sup>	2.05	3.2
		16-14	RM14M30K <sup>(1)</sup>	RC14M30K <sup>(1)</sup>	2.28	3.2
	Stamped & formed reeled contacts	26-24	SM24M1TK6 <sup>(1)(2)</sup>	SC24M1TK6 <sup>(1)(2)</sup>	0.89-1.28	-
		22-20	SM20M1TK6 <sup>(1)(2)</sup>	SC20M1TK6 <sup>(1)(2)</sup>	1.17-2.08	-
		18-16	SM16M1TK6 <sup>(1)(2)</sup>	SC16M1TK6 <sup>(1)(2)</sup>	3.0	-
18-16		SM16M11TK6 <sup>(1)(2)</sup>	SC16M11TK6 <sup>(1)(2)</sup>	2.0-3.0	-	
14		SM14M1TK6 <sup>(1)(2)</sup>	SC14M1TK6 <sup>(1)(2)</sup>	3.2	-	
PCB	Machined <sup>(3)</sup>	-	RM20M12E8K <sup>(1)</sup>	RC20M12E84K <sup>(1)</sup>	-	-
Coaxial	Cable Multipiece	-	RMDXK10D28	RCDXK1D28	-	-
	Cable Monocrimp	-	RMDX60xxD28	RCDX60xxD28	-	-
	Twisted pair Multipiece	-	RMDXK10D28 + york090	RCDXK1D28 + york090	-	-
	Twisted pair Monocrimp	-	RMDX60xxD28	RCDX60xxD28	-	-
Fiber optic	POF contacts Plastic optical fibre	-	RMPOF1000	RCPOF1000B	-	-

(1): Example of plating, for other plating see page 143  
 (2): Loose piece contact available if putting L. Example: SM20ML1-TK6  
 (3): For dimensions see page 148

Electrical characteristics
<p><b>UL</b> 10A 500V UL94 V-0</p> <p><b>CSA</b> 7A 500V UL94 V-0</p> <p><b>IEC</b> 10A 80V 1.5kV 3</p>

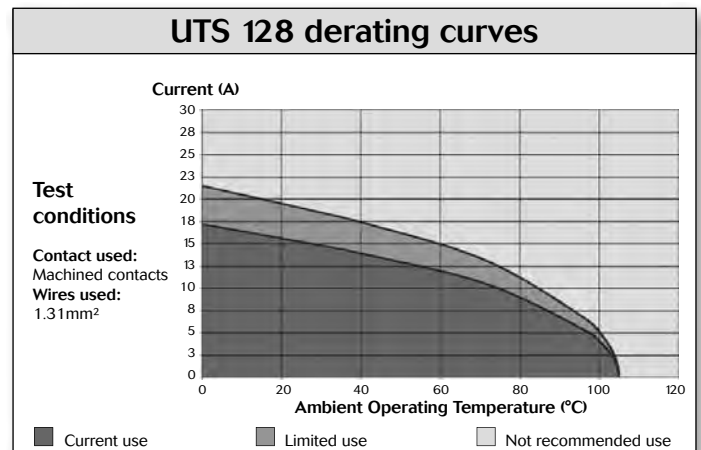

# UTS Series

## 12E8/12D8

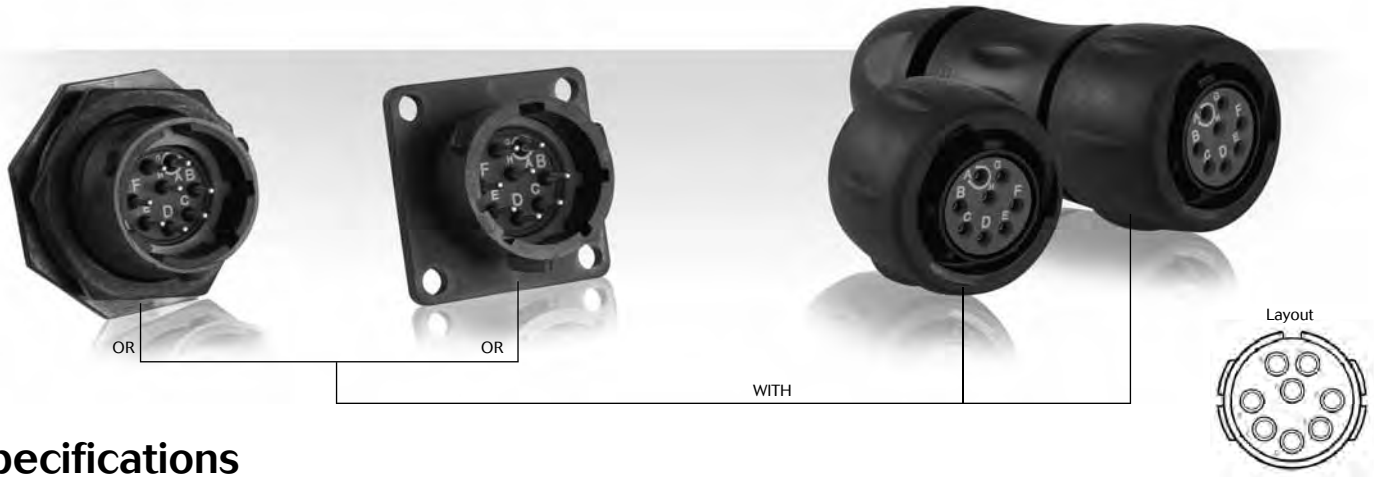

## Specifications

Contact type	Connector type	Backshell	Part number	
			Male insert	Female insert
Hand solder electrical contacts loaded	Square flange receptacle	Without (Fig.6)	UTS012E8P	UTS012E8S
	Plug	Without (Fig.1)	UTS612E8P	UTS612E8S
		Cable gland (Fig.2)	UTS6JC12E8P	UTS6JC12E8S
	Jam nut receptacle	Without (Fig.3)	UTS712E8P	UTS712E8S
PCB contacts loaded	Square flange receptacle	Without (Fig.7)	UTS012D8P	UTS012D8S
	Jam nut receptacle with stand off and with hold down clips	Without (Fig.4)	UTS712D8P32	UTS712D8S32
	Jam nut receptacle with stand off and without hold down clip	Without (Fig.5)	UTS712D8P	UTS712D8S

Sealed unmated



### Dimensions

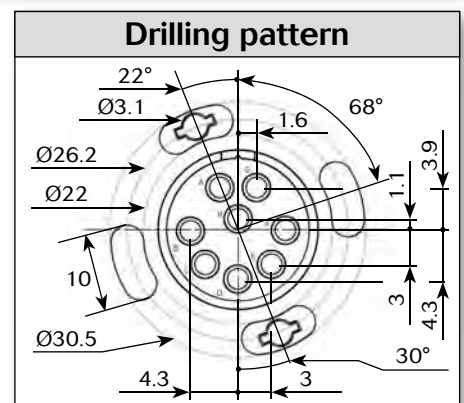
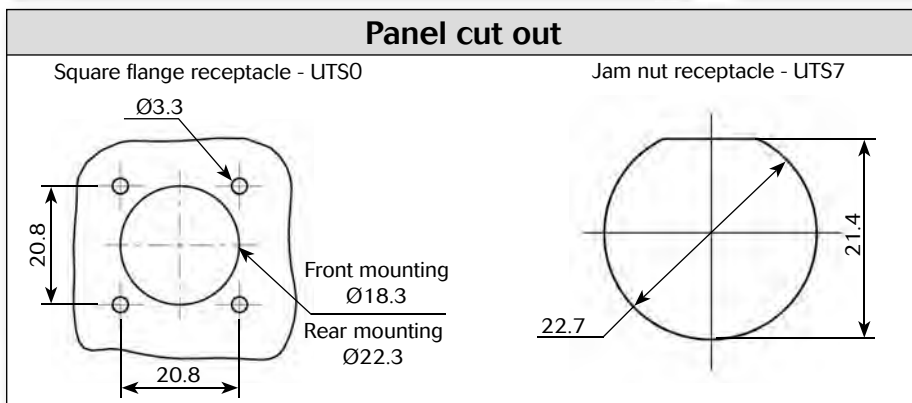
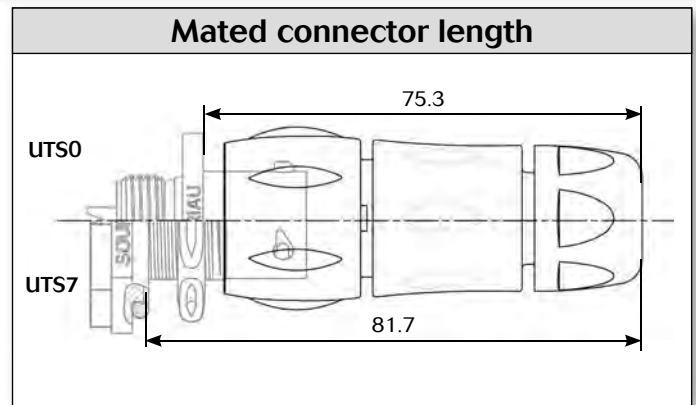
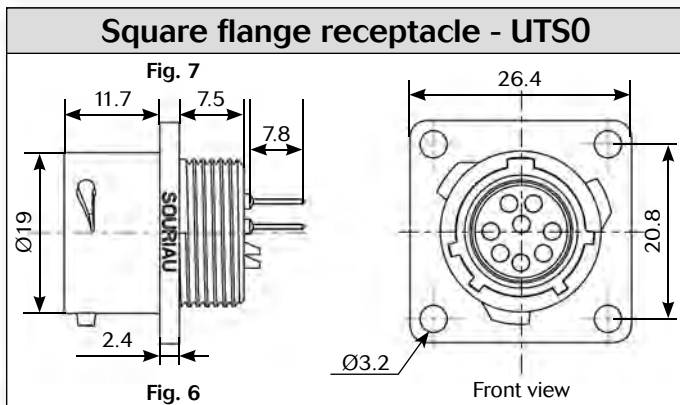
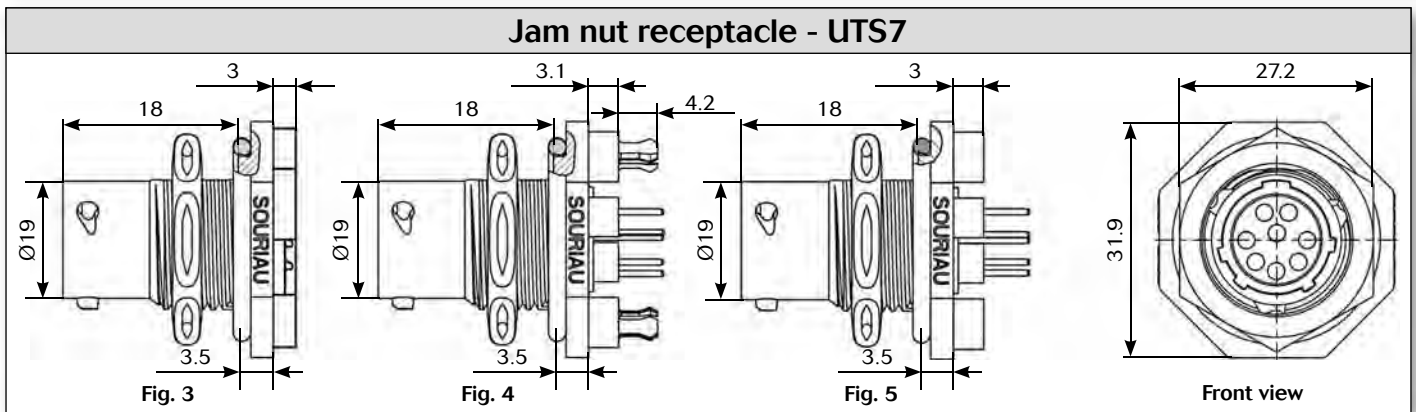
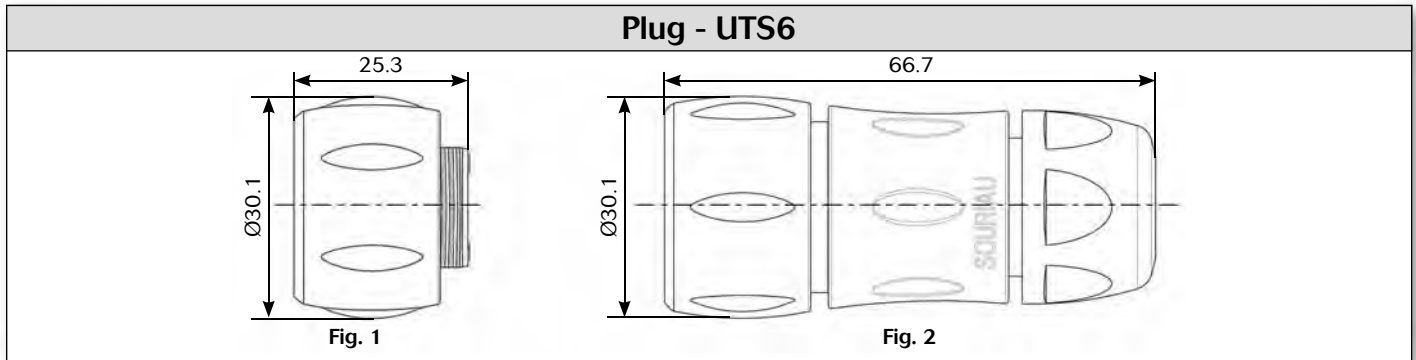



### Accessories

#### Jam nut sealing caps

Metal terminal

Part number
UTS12DCG

Part number
UTS12DCGR

#### Plug sealing cap

Part number
UTS612DCG

#### Square flange sealing cap

Metal terminal

Part number
UTS12DCGE

#### Plastic protective cap

Part numbers	
Receptacle cap	Plug cap
85005587A	85005596

#### Gasket

Part numbers / neoprene
UTFD13B

#### Color coding rings

G for Green  
Y for Yellow  
R for Red

Part numbers	
Receptacles	Plugs
UTS712CCR	UTS612CCR
UTS712CCRY	UTS612CCRY
UTS712CCRG	UTS612CCRG

\* Add G for Green, Y for Yellow, R for Red

#### Electrical characteristics

**UL**  
4.5A 250V UL94 HB

**CSA**  
4.5A 250V UL94 HB

**IEC**  
6A 32V 1.5kV 3

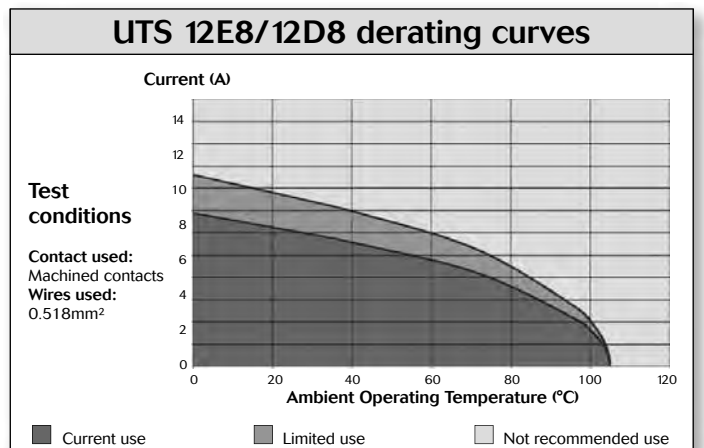

# UTS Series

12E8/12D8





# UTS Series

## 1210 - 12E10/12D10

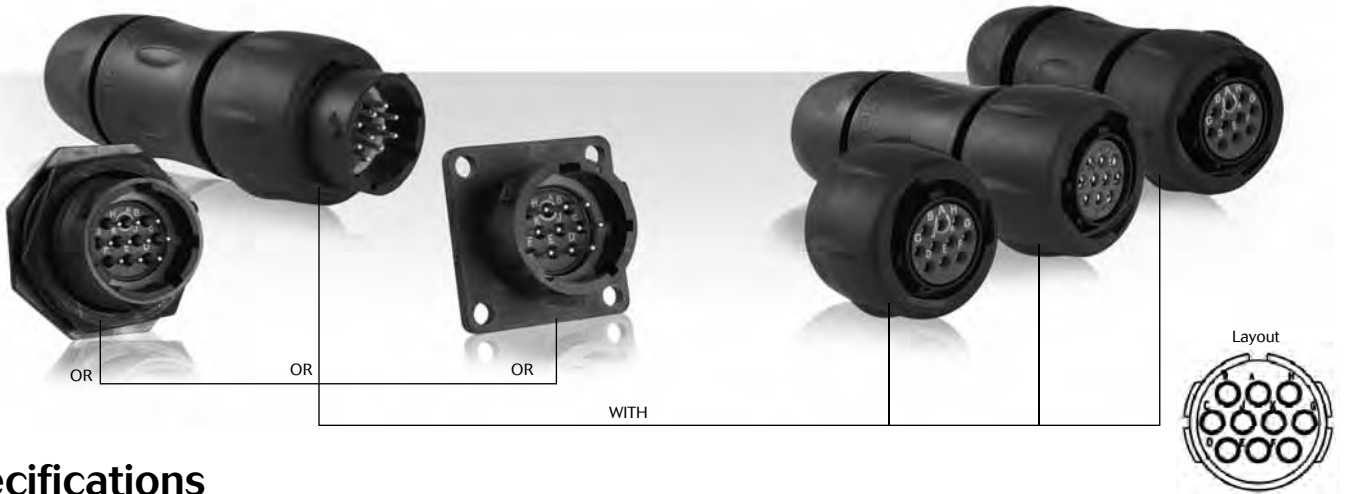

### Specifications

Contact type	Connector type	Backshell	Part number	
			Male insert	Female insert
Crimp contacts supply separately see page107	Free hanging receptacle	Cable gland (Fig.1)	UTS1JC1210P	UTS1JC1210S
	Plug	Without (Fig.2)	UTS61210P	UTS61210S
	Plug	Cable gland (Fig.3)	UTS6JC1210P	UTS6JC1210S
	Jam nut receptacle	Without (Fig.4)	UTS71210P	UTS71210S
Handsolder electrical contacts loaded	Square flange receptacle	Without (Fig.6)	UTS012E10P	UTS012E10S
	Plug	Without (Fig.2)	UTS612E10P	UTS612E10S
		Cable gland (Fig.3)	UTS6JC12E10P	UTS6JC12E10S
	Jam nut receptacle	Without (Fig.5)	UTS712E10P	UTS712E10S
PCB contacts loaded	Square flange receptacle	Without (Fig.7)	UTS012D10P	UTS012D10S
	Jam nut receptacle with stand off and with hold down clips	Without (Fig.6)	UTS712D10P32	UTS712D10S32
	Jam nut receptacle with stand off and without hold down clip	Without (Fig.7)	UTS712D10P	UTS712D10S

Sealed unmated

# UTS Series

## 1210 - 12E10/12D10



10 contacts  
6A/50V  
per IEC 61984

### Dimensions

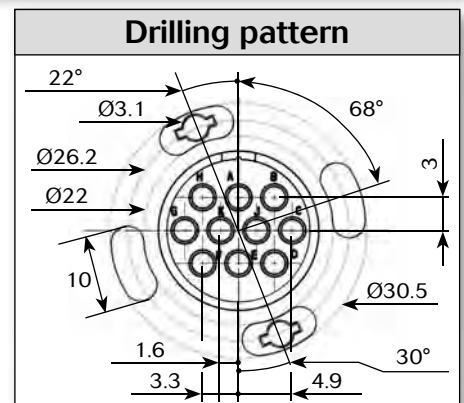
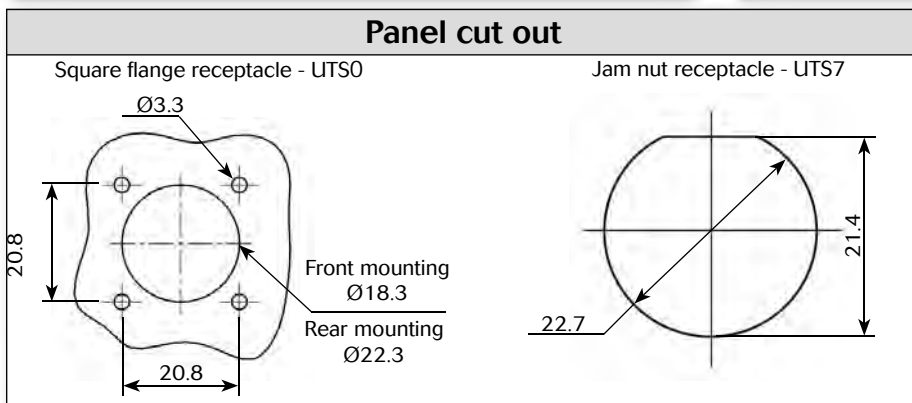
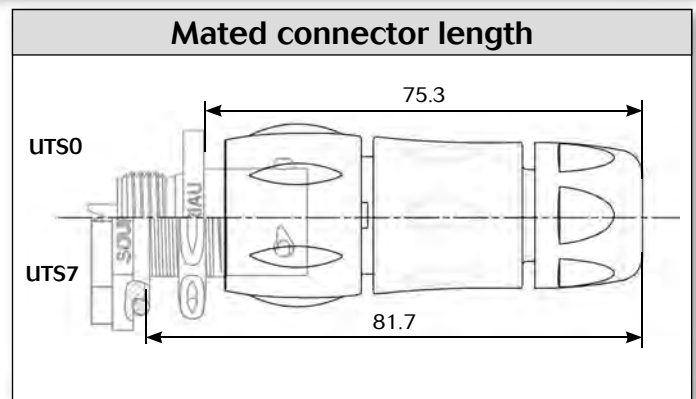
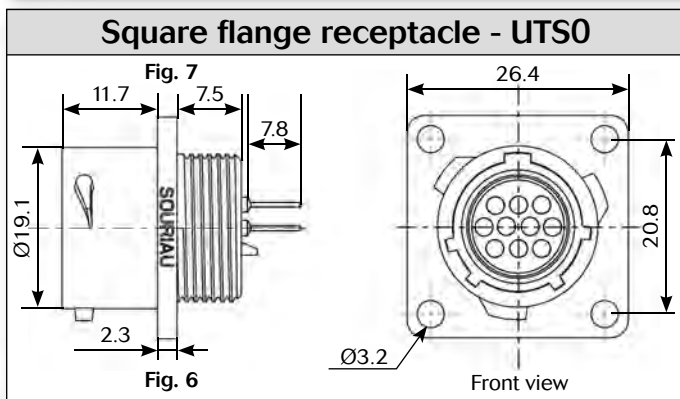
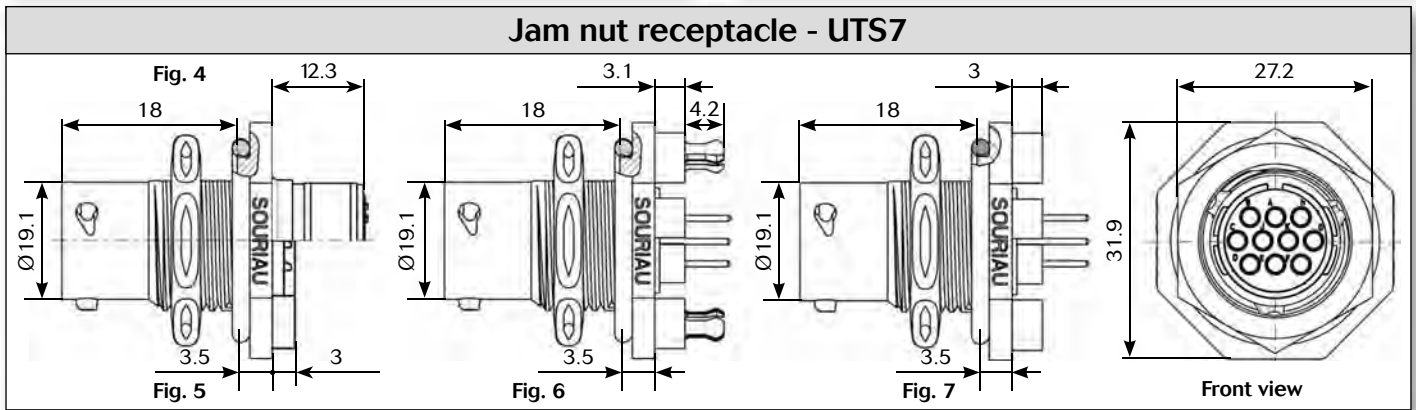
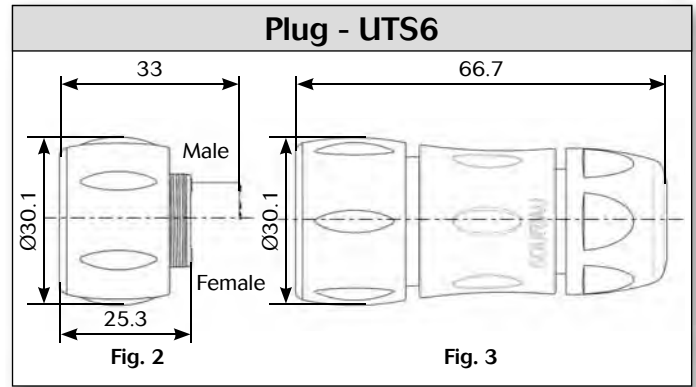
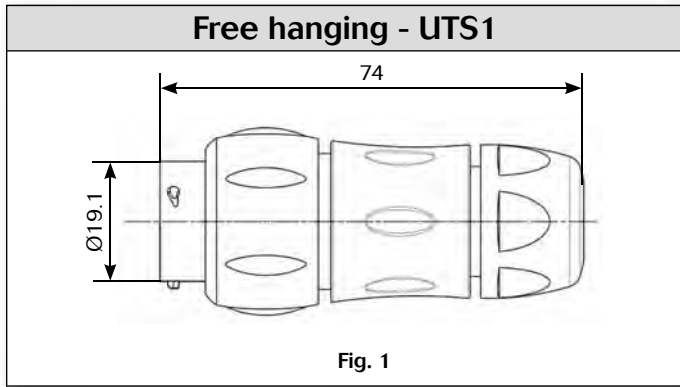

Note: all dimensions are in mm



### Accessories and tooling

Jam nut sealing caps	
	
Part number	Metal terminal
UTS12DCG	UTS12DCGR

Handle

Part number
SHANGLES

Tool kit

Part number
TOOLKIT

Plug sealing cap

Part number
UTS612DCG

Square flange sealing cap



Metal terminal
Part number
UTS12DCGE

Plastic protective cap	
	
Part numbers	
Receptacle cap	Plug cap
85005587A	85005596

Gasket

Part numbers / neoprene
UTFD13B

Crimp tooling		
		
Contacts	Contact size	Part number of head
RM/RC 24W3K <sup>(1)</sup>	Standard contacts #20 Ø 1mm	S20RM
RM/RC 20W3K <sup>(1)</sup>		S20RM
RM/RC 18W3K <sup>(1)</sup>		S20RM
SM/SC 24W3S <sup>(2)</sup>		S20SCM20
SM/SC 24WL3S <sup>(3)</sup>		S20SCM20
SM/SC 20W3S <sup>(2)</sup>		S20SCM20
SM/SC 20WL3S <sup>(3)</sup>		S20SCM20

(1): example of plating, for other plating see UTS catalog page 143  
 (2): contact reeled  
 (3): loose contact

Color coding rings	
G for Green	
Y for Yellow	
R for Red	
Part numbers	
Receptacles	Plugs
UTS712CCRR	UTS612CCRR
UTS712CCRY	UTS612CCRY
UTS712CCRG	UTS612CCRG

\* Add G for Green, Y for Yellow, R for Red

# UTS Series

## 1210 - 12E10/12D10



10 contacts  
6A/50V  
per IEC 61984

### Contacts

#20	Contact type	AWG	Part number		Max wire Ø	Max insulator Ø
			Male	Female		
Crimp	Machined	26-24	RM24W3K <sup>(1)</sup>	RC24W3K <sup>(1)</sup>	-	1.58
		22-20	RM20W3K <sup>(1)</sup>	RC20W3K <sup>(1)</sup>	-	1.58
		20-18	RM18W3K <sup>(1)</sup>	RC18W3K <sup>(1)</sup>	-	2.1
	stamped & formed reeled contacts	26-24	SM24W3TK6 <sup>(2)</sup>	SC24W3TK6 <sup>(2)</sup>	-	0.89-1.58
		26-24	SM24W3TK6 <sup>(2)</sup>	SC24W3TK6 <sup>(2)</sup>	-	0.89-1.58
		22-20	SM20W3TK6 <sup>(2)</sup>	SC20W3TK6 <sup>(2)</sup>	-	1.17-2.08
		22-20	SM20W3TK6 <sup>(2)</sup>	SC20W3TK6 <sup>(2)</sup>	-	1.17-2.08
	PCB	Machined <sup>(3)</sup>	-	RMW5016K	RCW5016K	-

(1): Example of plating, for other plating see page 143  
 (2): Loose piece contact available if putting L. Example: SM20ML1-TK6  
 (3): For dimensions see page 148

Electrical characteristics	
<b>UTS 1210</b> <b>UL</b> 5A 250V UL94 V-0	<b>UTS 12E10/12D10</b> <b>UL</b> 4.5A 250V UL94 HB
<b>CSA</b> 4A 250V UL94 V-0	<b>CSA</b> 4.5A 250V UL94 HB
<b>IEC</b> 6A 50V 1.5kV 3	

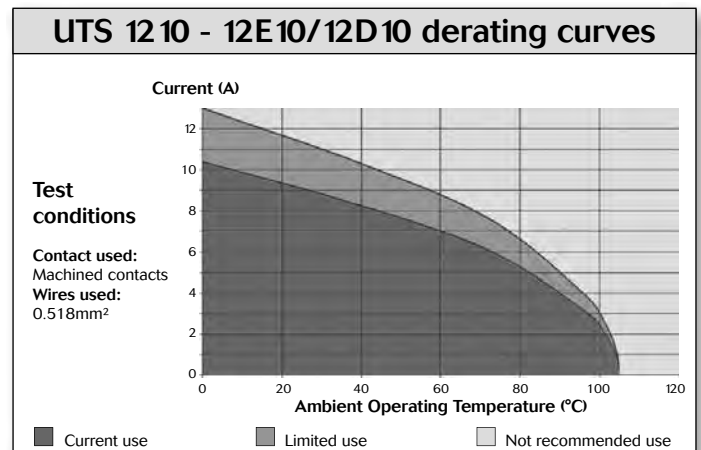

# UTS Series 1412

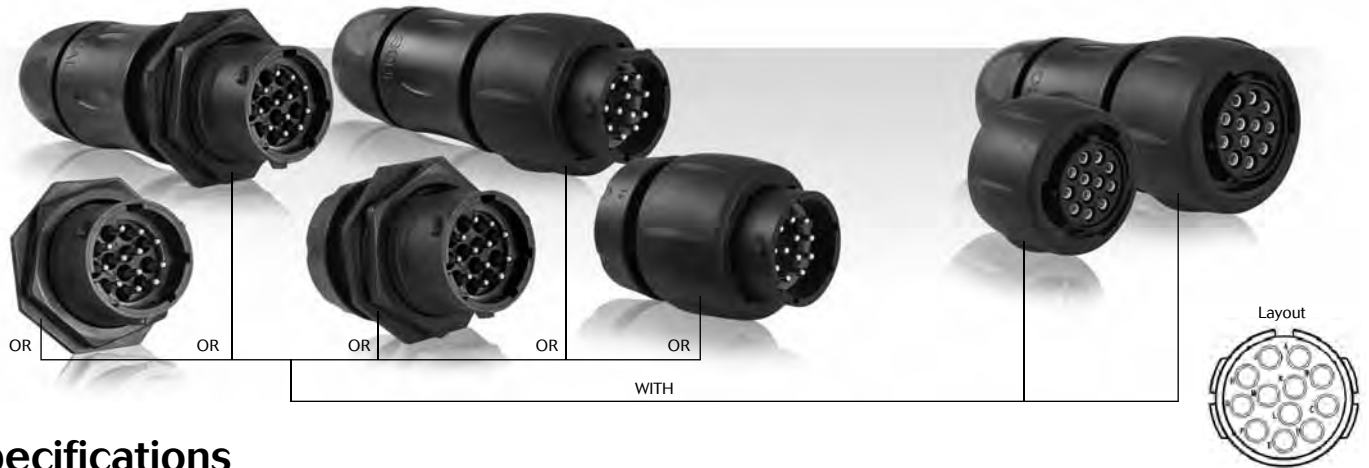

## Specifications

Contact type	Connector type	Backshell	Part number	
			Male insert	Female insert
Crimp contacts supply separately see page 111	Square flange receptacle	Without (Fig.1)	UTS01412P	UTS01412S
	Free hanging receptacle	Cable gland and grommet (Fig.2)	UTS1GJC1412P	
	Free hanging receptacle	Nut and grommet (Fig.3)	UTS1GN1412P	
	Free hanging receptacle	Cable gland (Fig.2)	UTS1JC1412P	UTS1JC1412S
	Plug	Without (Fig.4)	UTS61412P	UTS61412S
	Plug	Cable gland and grommet (Fig.5)		UTS6GJC1412S
	Plug	Nut and grommet (Fig.6)		UTS6GN1412S
	Plug	Cable gland (Fig.5)	UTS6JC1412P	UTS6JC1412S
	Jam nut receptacle	Without (Fig.7)	UTS71412P	UTS71412S
	Jam nut receptacle	Cable gland and grommet (Fig.9)	UTS7GJC1412P	
	Jam nut receptacle	Nut and grommet (Fig.8)	UTS7GN1412P	
PCB contacts supply separately see page 111	Square flange receptacle	Without (Fig.1)	UTS01412P	UTS01412S
	Jam nut receptacle	Without (Fig.7)	UTS71412P	UTS71412S



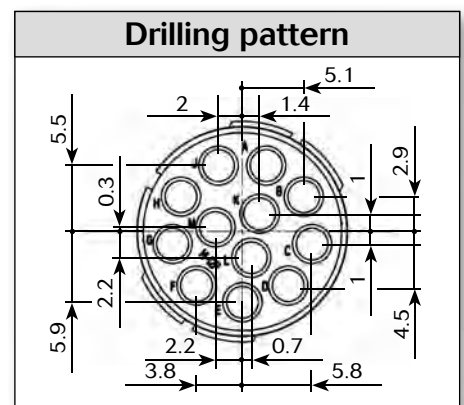
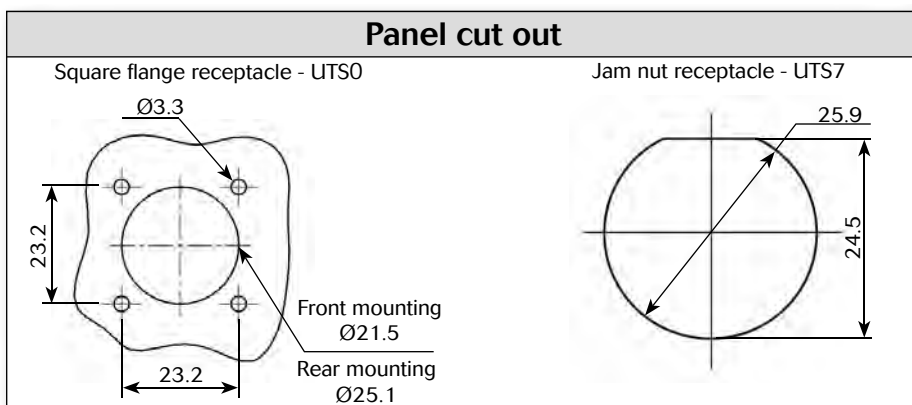
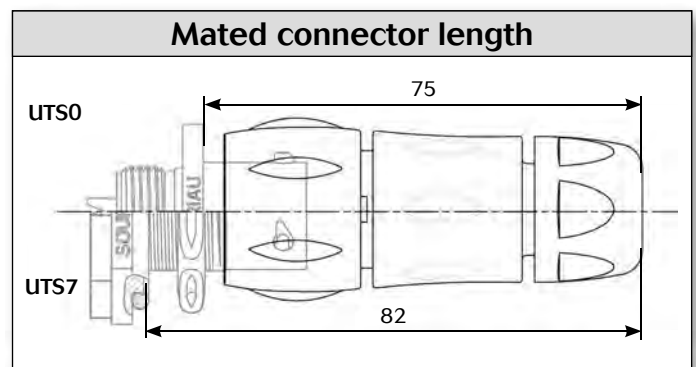
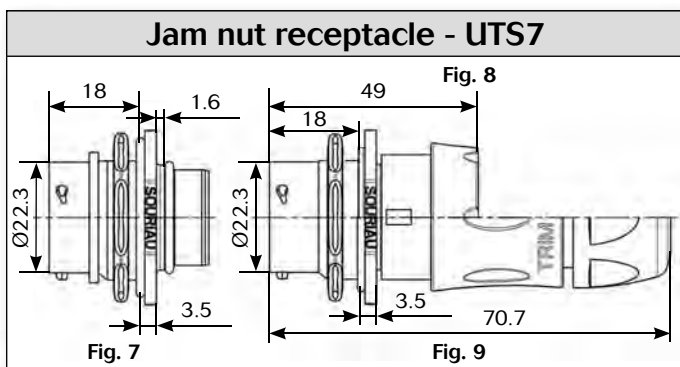
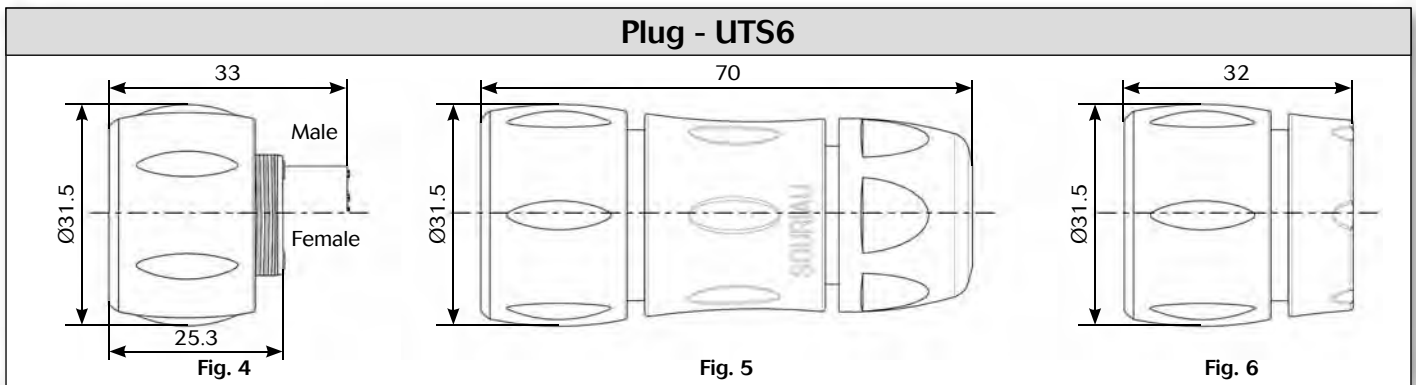
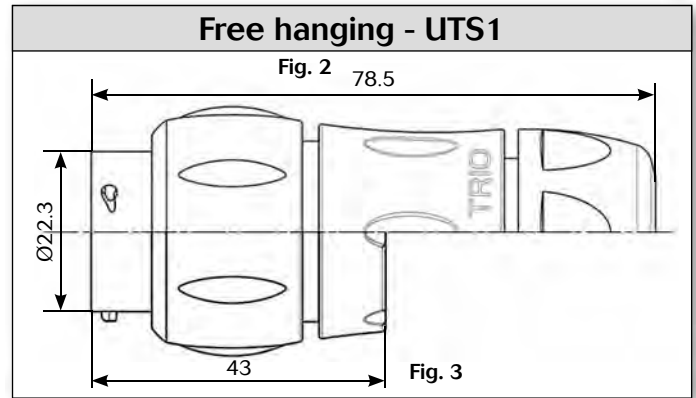
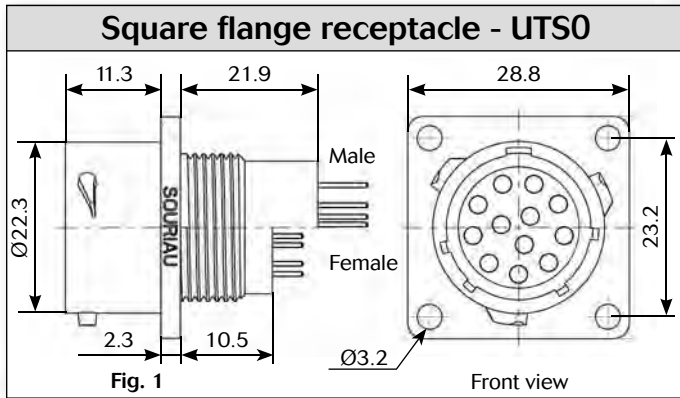

### Dimensions





### Accessories and tooling

Jam nut sealing caps	
	
Part number	Part number
UTS14DCG	UTS14DCGR

Metal terminal

Handle

Part number
SHANGLES

Tool kit

Part number
TOOLKIT

Plug sealing cap

Part number
UTS614DCG





Square flange sealing cap

Part number
UTS14DCGE

Metal terminal

Plastic protective cap	
	
Part numbers	
Receptacle cap	Plug cap
85005588A	85005597

Gasket

Part numbers / neoprene
UTFD14B

Color coding rings												
G for Green		<table border="1"> <thead> <tr> <th colspan="2">Part numbers</th> </tr> <tr> <th>Receptacles</th> <th>Plugs</th> </tr> </thead> <tbody> <tr> <td>UTS714CCRR</td> <td>UTS614CCRR</td> </tr> <tr> <td>UTS714CCRY</td> <td>UTS614CCRY</td> </tr> <tr> <td>UTS714CCRG</td> <td>UTS614CCRG</td> </tr> </tbody> </table>	Part numbers		Receptacles	Plugs	UTS714CCRR	UTS614CCRR	UTS714CCRY	UTS614CCRY	UTS714CCRG	UTS614CCRG
Part numbers												
Receptacles	Plugs											
UTS714CCRR	UTS614CCRR											
UTS714CCRY	UTS614CCRY											
UTS714CCRG	UTS614CCRG											
Y for Yellow												
												
R for Red												

\* Add G for Green, Y for Yellow, R for Red

Crimp tooling			
			
Contacts	Contact size	Part number of head	
RM/RC 28M1K <sup>(1)</sup>	Standard contacts #16 Ø 1.6mm	S16RCM20	
RM/RC 24M9K <sup>(1)</sup>		S16RCM20	
RM/RC 20M13K <sup>(1)</sup>		S16RCM20	
RM/RC 20M12K <sup>(1)</sup>		S16RCM20	
RM/RC 16M23K <sup>(1)</sup>		S16RCM16	
RM/RC 14M50K <sup>(1)</sup>		S16RCM1450	
RM/RC 14M30K <sup>(1)</sup>		S16RCM14	
SM/SC 24ML1TK6 <sup>(1)</sup>		S16SCM20	
SM/SC 20ML1TK6 <sup>(1)</sup>		S16SCM20	
SM/SC 16ML1TK6 <sup>(1)</sup>		S16SCML1	
SM/SC 14ML1TK6 <sup>(1)</sup>		S16SCML1	
SM/SC 16ML1TK6 <sup>(1)</sup>		S16SCML11	
RMDXK10D28K		Coaxial contacts	M10S-1J
RCDXK1D28K			M10S-1J
RM/RC DX60xxD28K	M10S-1J		
RM/RC DXK10D28 + york090	M10S-1J		
RM/RC DX60xxD28		M10S-1J	

(1): example of plating, for other plating see UTS catalog page 143



### Contacts

#16	Contact type	AWG	Part number		Max wire Ø	Max insulator Ø
			Male	Female		
Crimp	Machined	30-28	RM28M1K <sup>(1)</sup>	RC28M1K <sup>(1)</sup>	0.55	1.1
		26-24	RM24M9K <sup>(1)</sup>	RC24M9K <sup>(1)</sup>	0.8	1.6
		22-20	RM20M13K <sup>(1)</sup>	RC20M13K <sup>(1)</sup>	1.18	1.8
		22-20	RM20M12K <sup>(1)</sup>	RC20M12K <sup>(1)</sup>	1.18	2.2
		20-16	RM16M23K <sup>(1)</sup>	RC16M23K <sup>(1)</sup>	1.8	3.2
		16-14	RM14M50K <sup>(1)</sup>	RC14M50K <sup>(1)</sup>	2.05	3.2
		16-14	RM14M30K <sup>(1)</sup>	RC14M30K <sup>(1)</sup>	2.28	3.2
	Stamped & formed reeled contacts	26-24	SM24M1TK6 <sup>(1)(2)</sup>	SC24M1TK6 <sup>(1)(2)</sup>	0.89-1.28	-
		22-20	SM20M1TK6 <sup>(1)(2)</sup>	SC20M1TK6 <sup>(1)(2)</sup>	1.17-2.08	-
		18-16	SM16M1TK6 <sup>(1)(2)</sup>	SC16M1TK6 <sup>(1)(2)</sup>	3.0	-
18-16		SM16M11TK6 <sup>(1)(2)</sup>	SC16M11TK6 <sup>(1)(2)</sup>	2.0-3.0	-	
14		SM14M1TK6 <sup>(1)(2)</sup>	SC14M1TK6 <sup>(1)(2)</sup>	3.2	-	
PCB	Machined <sup>(3)</sup>	-	RM20M12E8K <sup>(1)</sup>	RC20M12E84K <sup>(1)</sup>	-	-
Coaxial	Cable Multipiece	-	RMDXK10D28	RCDXK1D28	-	-
	Cable Monocrimp	-	RMDX60xxD28	RCDX60xxD28	-	-
	Twisted pair Multipiece	-	RMDXK10D28 + york090	RCDXK1D28 + york090	-	-
	Twisted pair Monocrimp	-	RMDX60xxD28	RCDX60xxD28	-	-
Fiber optic	POF contacts Plastic optical fibre	-	RMPOF1000	RCPOF1000B	-	-

(1): Example of plating, for other plating see page 143  
 (2): Loose piece contact available if putting L. Example: SM20ML1-TK6  
 (3): For dimensions see page 148

#### Electrical characteristics

**UL**  
10A 500V UL94 V-0

**CSA**  
7A 500V UL94 V-0

**IEC**  
10A 63V 1.5kV 3

#### UTS 1412 derating curves

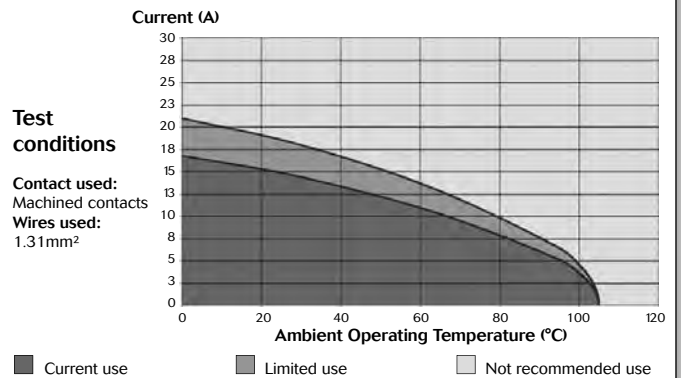



# UTS Series

14E12/14D12 (4x#16 + 8x#20)

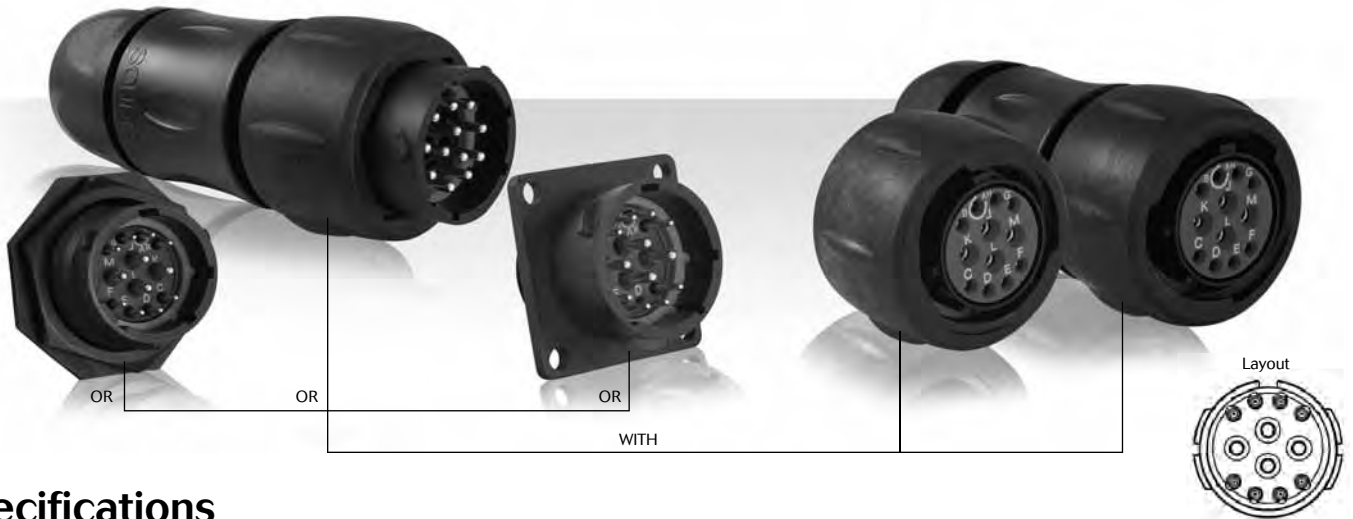

## Specifications

Contact type	Connector type	Backshell	Part number	
			Male insert	Female insert
Hand solder electrical contacts loaded	Square flange receptacle	Without (Fig.6)	UTS014E12P	UTS014E12S
	Plug	Without (Fig.1)	UTS614E12P	UTS614E12S
		Cable gland (Fig.2)	UTS6JC14E12P	UTS6JC14E12S
	Jam nut receptacle	Without (Fig.3)	UTS714E12P	UTS714E12S
PCB contacts loaded	Square flange receptacle	Without (Fig.6)	UTS014D12P	UTS014D12S
	Jam nut receptacle with stand off and with hold down clips	Without (Fig.4)	UTS714D12P32	UTS714D12S32
	Jam nut receptacle with stand off and without hold down clip	Without (Fig.5)	UTS714D12P	UTS714D12S

Sealed unmatred

# UTS Series

14E12/14D12 (4x#16 + 8x#20)



12 contacts  
4A/50V  
per IEC 61984

## Dimensions

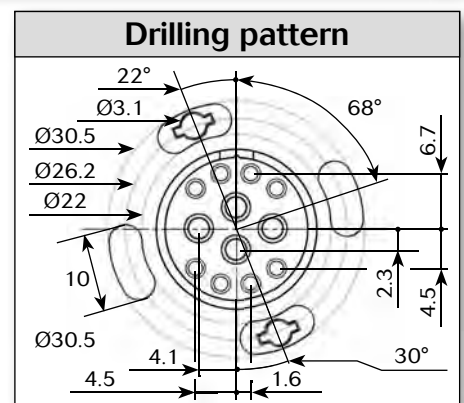
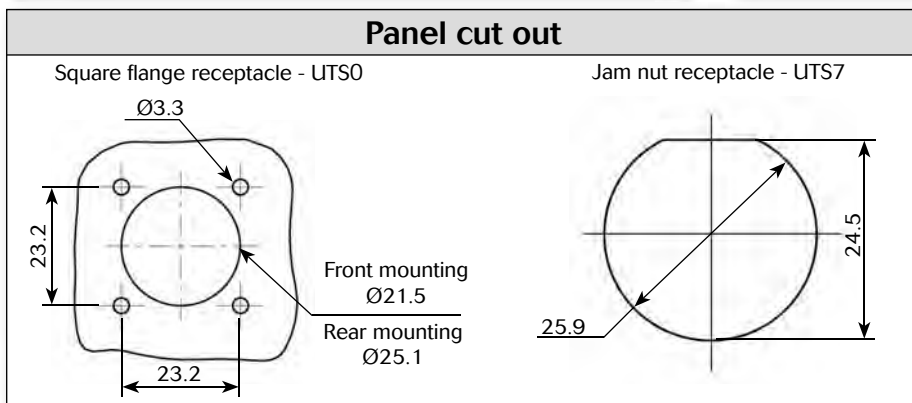
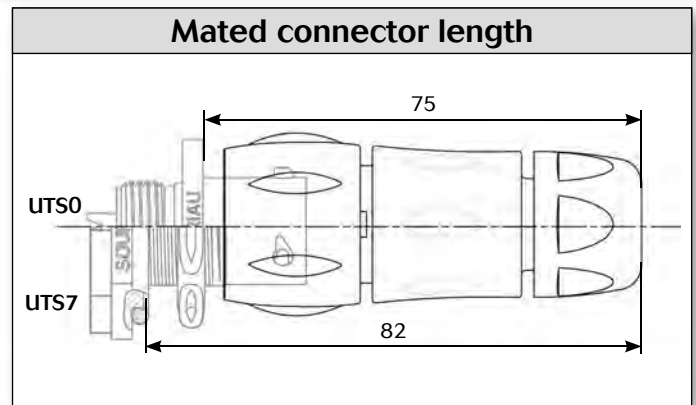
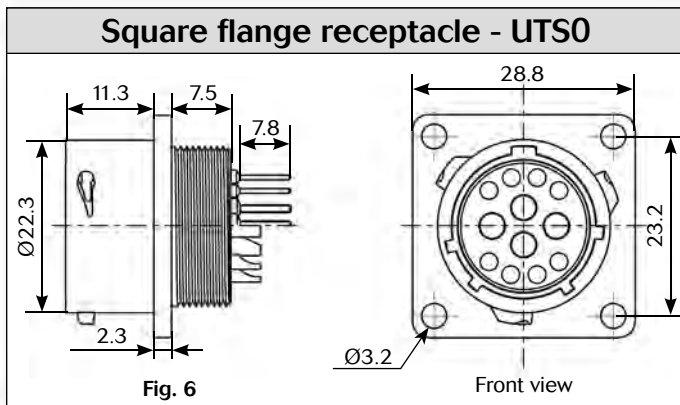
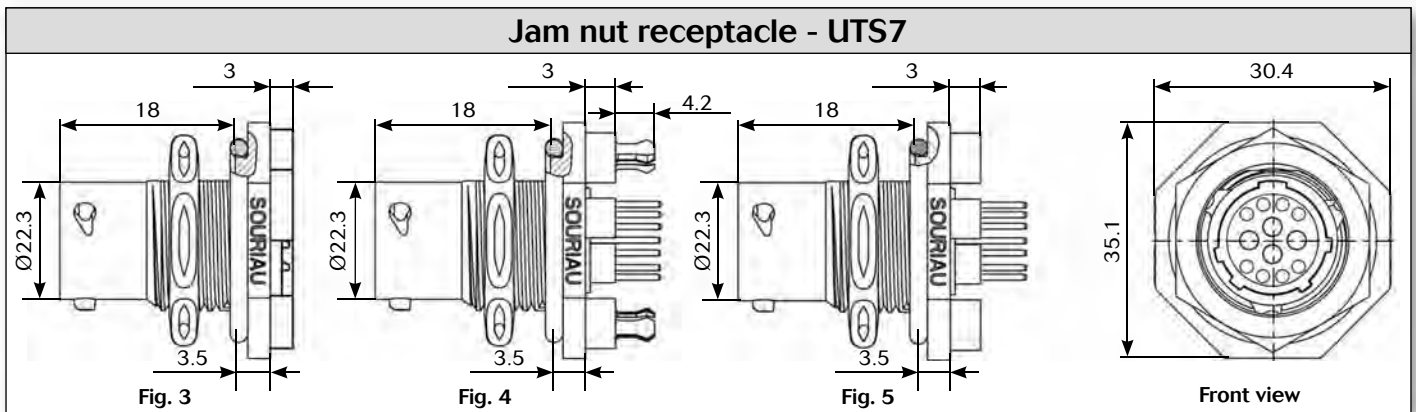
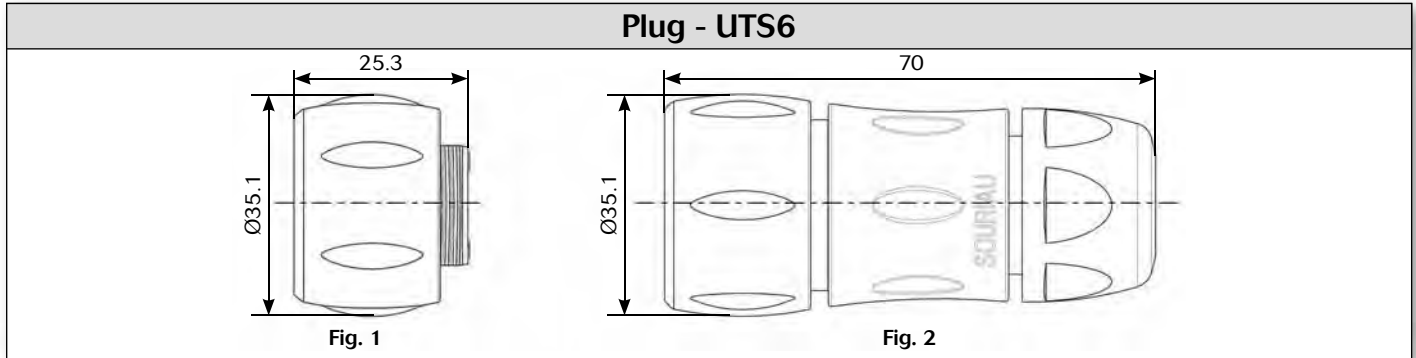

# UTS Series

14E12/14D12 (4x#16 + 8x#20)



## Accessories

### Jam nut sealing caps

Metal terminal

Part number	Part number
UTS14DCG	UTS14DCGR

### Plug sealing cap

Part number
UTS614DCG

### Square flange sealing cap

Metal terminal

Part number
UTS14DCGE

### Plastic protective cap

Part numbers	
Receptacle cap	Plug cap
85005588A	85005597

### Gasket

Part numbers / neoprene
UTFD14B

### Color coding rings

G for Green  
Y for Yellow  
R for Red

Part numbers	
Receptacles	Plugs
UTS714CCR	UTS614CCR
UTS714CCRY	UTS614CCRY
UTS714CCRG	UTS614CCRG

\* Add G for Green, Y for Yellow, R for Red

### Electrical characteristics

**UL**  
4.5A 250V UL94 HB

**CSA**  
4.5A 250V UL94 HB

**IEC**  
4A 50V 1.5kV 3

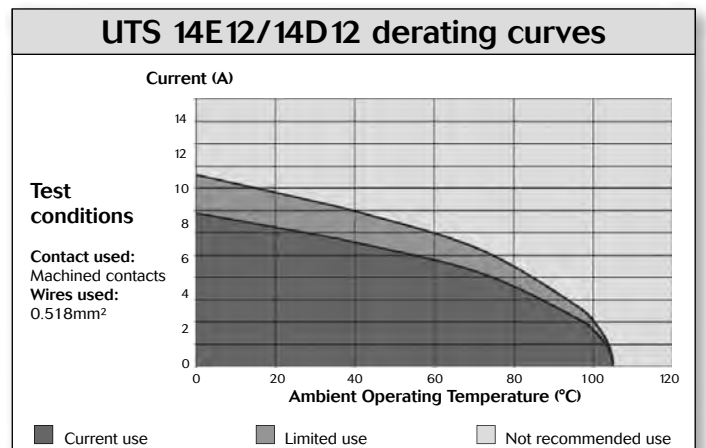

# UTS Series

14E12/14D12 (4x#16 + 8x#20)



# UTS Series

## 12E14/12D14

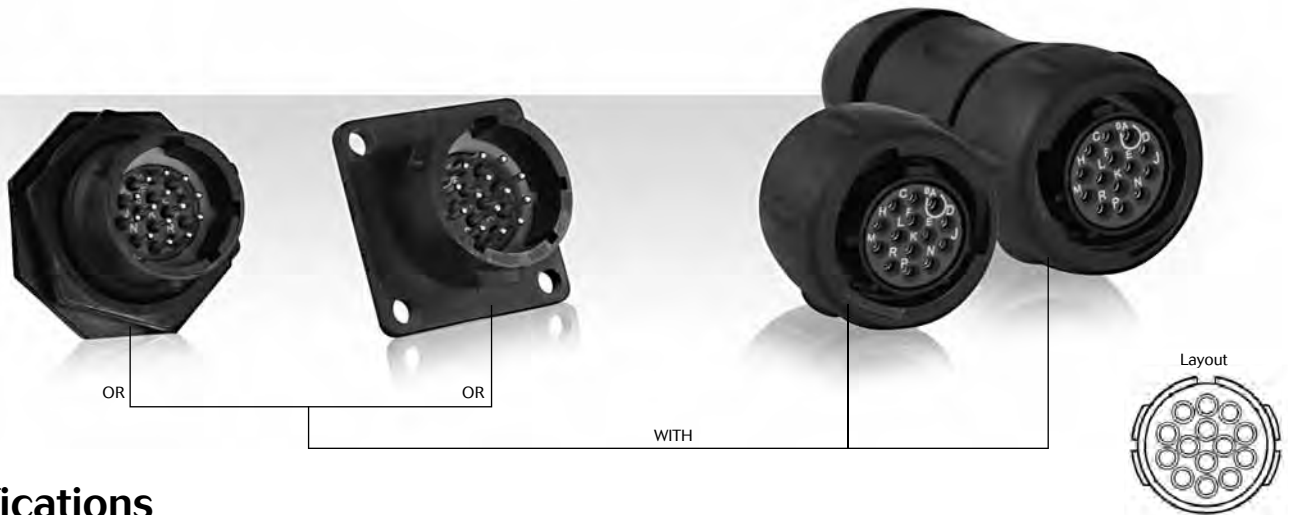
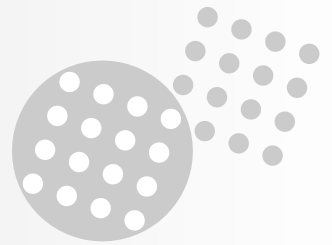

## Specifications

Contact type	Connector type	Backshell	Part number	
			Male insert	Female insert
Hand solder electrical contacts loaded	Square flange receptacle	Without (Fig.6)	UTS012E14P	UTS012E14S
	Plug	Without (Fig.1)	UTS612E14P	UTS612E14S
		Cable gland (Fig.2)	UTS6JC12E14P	UTS6JC12E14S
	Jam nut receptacle	Without (Fig.3)	UTS712E14P	UTS712E14S
PCB contacts loaded	Square flange receptacle	Without (Fig.7)	UTS012D14P	UTS012D14S
	Jam nut receptacle with stand off and with hold down clips	Without (Fig.4)	UTS712D14P32	UTS712D14S32
	Jam nut receptacle with stand off and without hold down clip	Without (Fig.5)	UTS712D14P	UTS712D14S

Sealed unmated



### Dimensions

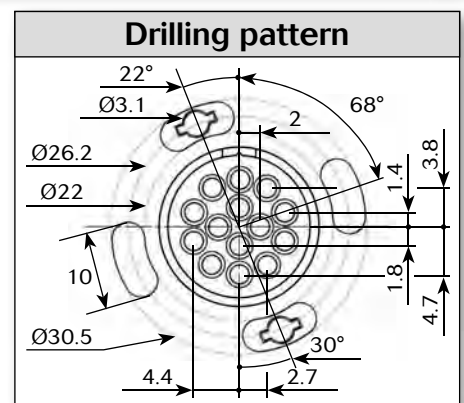
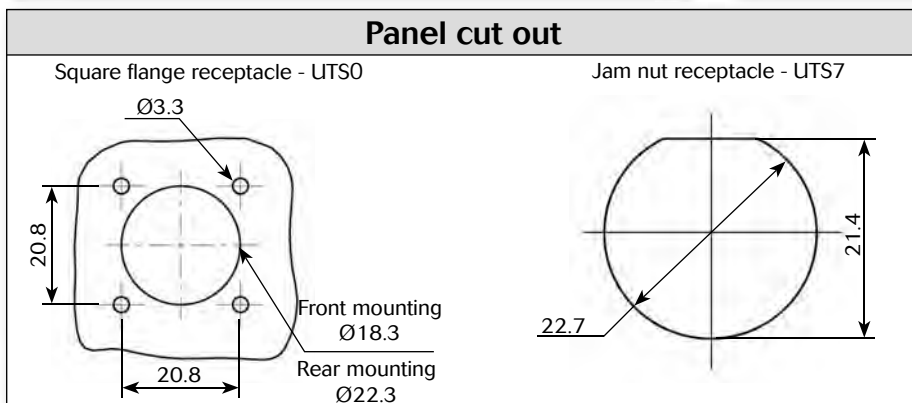
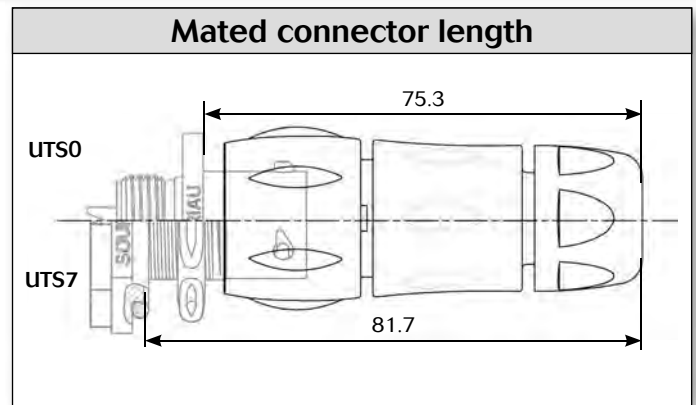
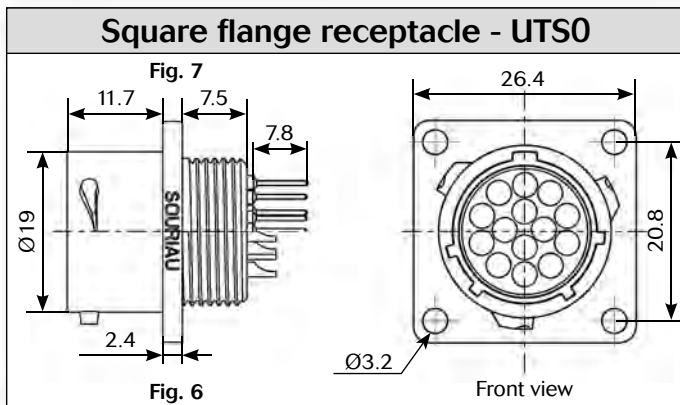
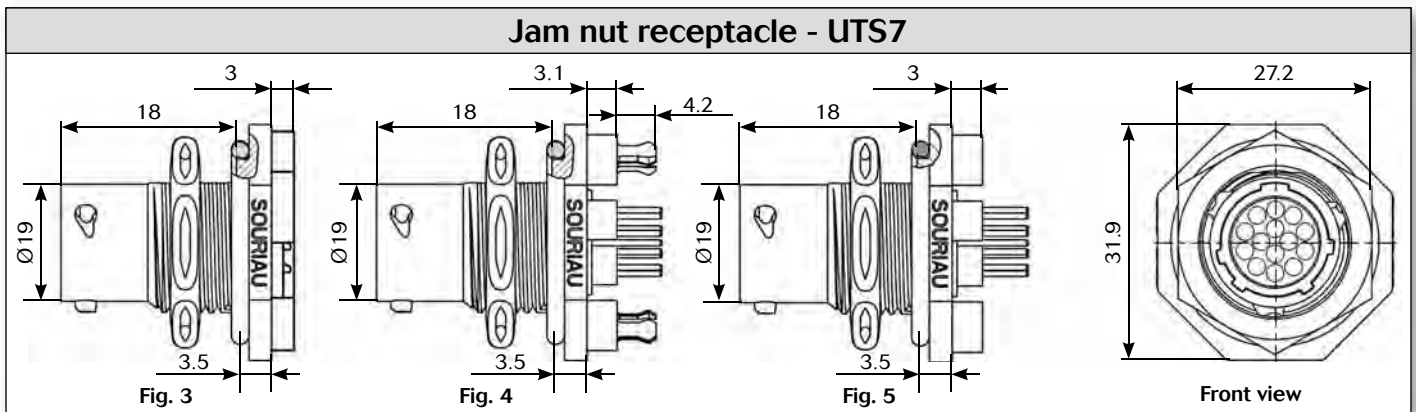
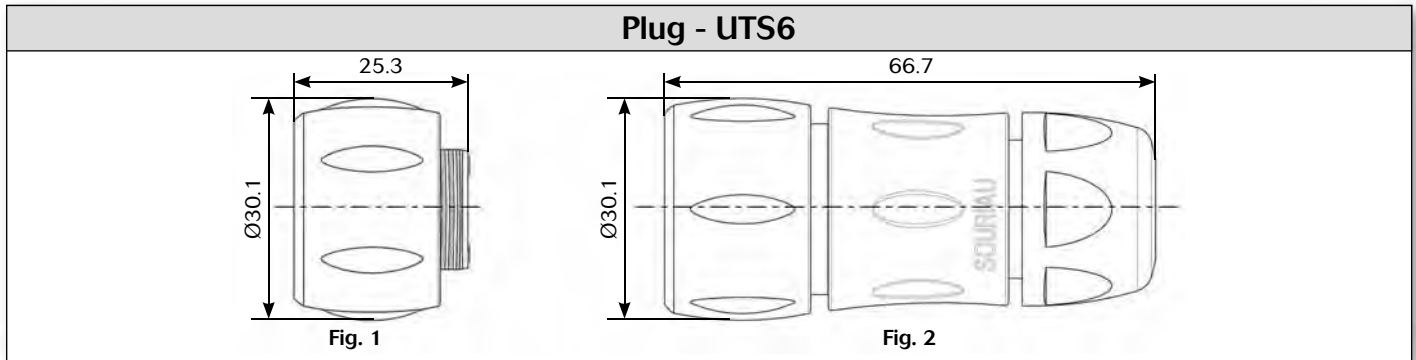

Note: all dimensions are in mm



### Accessories

#### Jam nut sealing caps

Part number	Part number
UTS12DCG	UTS12DCGR

Metal terminal

#### Plug sealing cap

Part number
UTS612DCG

#### Square flange sealing cap

Part number
UTS12DCGE

Metal terminal

#### Plastic protective cap

Part numbers	
Receptacle cap	Plug cap
85005587A	85005596

#### Gasket

Part numbers / neoprene
UTFD13B

#### Color coding rings

Part numbers	
Receptacles	Plugs
UTS712CCR	UTS612CCR
UTS712CCRY	UTS612CCRY
UTS712CCRG	UTS612CCRG

\* Add G for Green, Y for Yellow, R for Red

#### Electrical characteristics

**UL**  
4.5A 250V UL94 HB

**CSA**  
4.5A 250V UL94 HB

**IEC**  
5A 32V 1.5kV 3

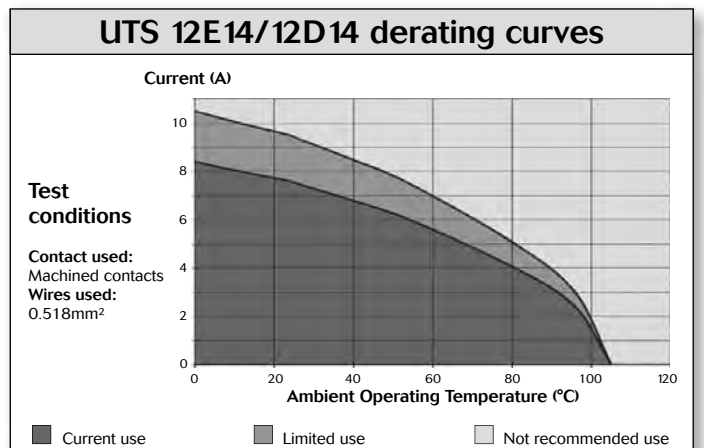

UTS Series  
12E14/12D14





# UTS Series

## 14E 15/14D 15

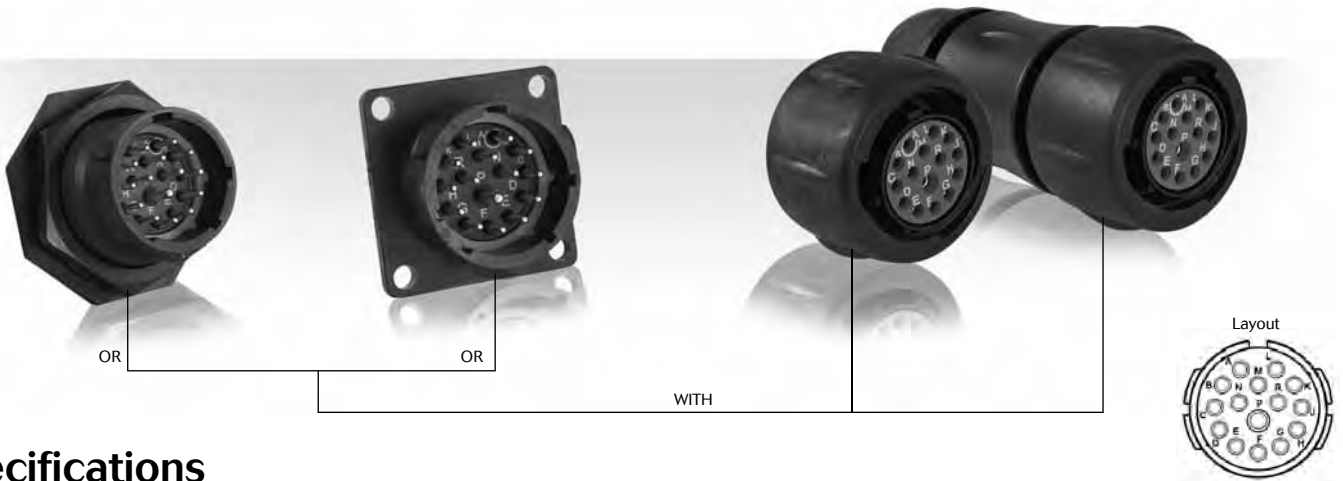

### Specifications

Contact type	Connector type	Backshell	Part number	
			Male insert	Female insert
Hand solder electrical contacts loaded	Square flange receptacle	Without (Fig.6)	UTS014E15P	UTS014E15S
	Plug	Without (Fig.1)	UTS614E15P	UTS614E15S
		Cable gland (Fig.2)	UTS6JC14E15P	UTS6JC14E15S
	Jam nut receptacle	Without (Fig.3)	UTS714E15P	UTS714E15S
PCB contacts loaded	Square flange receptacle	Without (Fig.7)	UTS014D15P	UTS014D15S
	Jam nut receptacle with stand off and with hold down clips	Without (Fig.4)	UTS714D15P32	UTS714D15S32
	Jam nut receptacle with stand off and without hold down clip	Without (Fig.5)	UTS714D15P	UTS714D15S

Sealed unmatred



### Dimensions

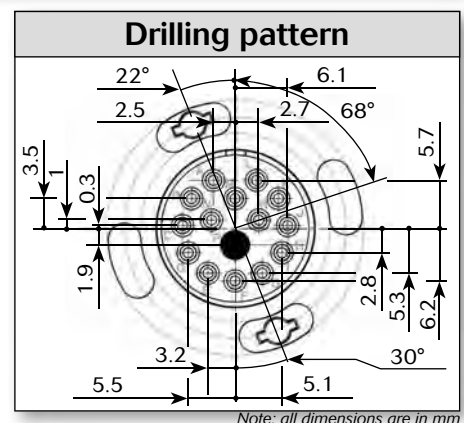
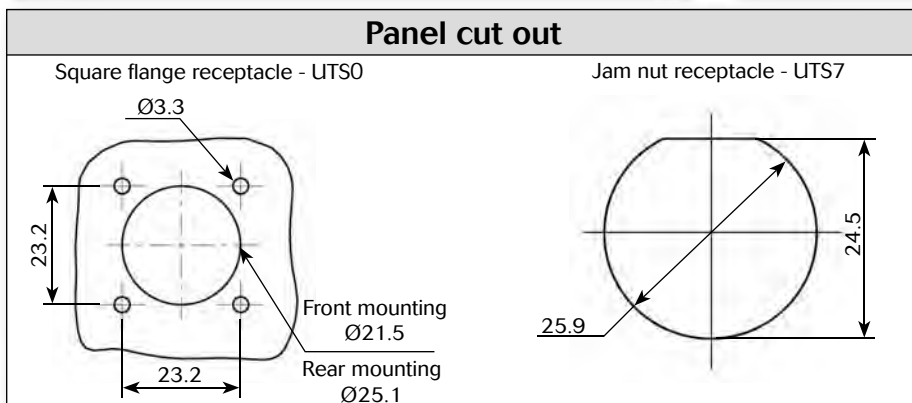
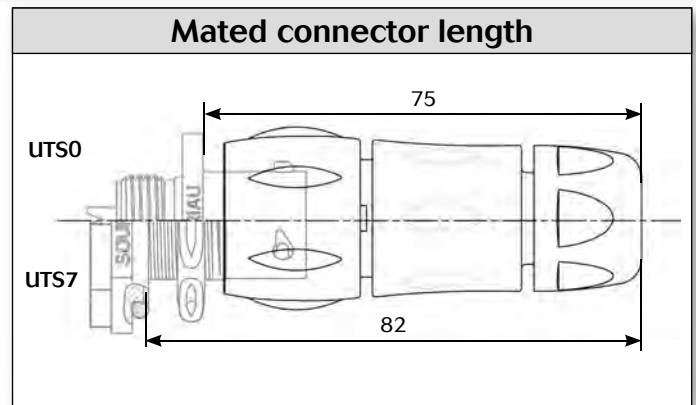
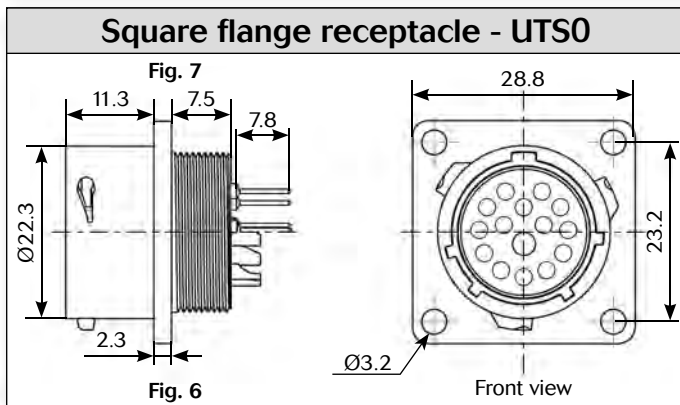
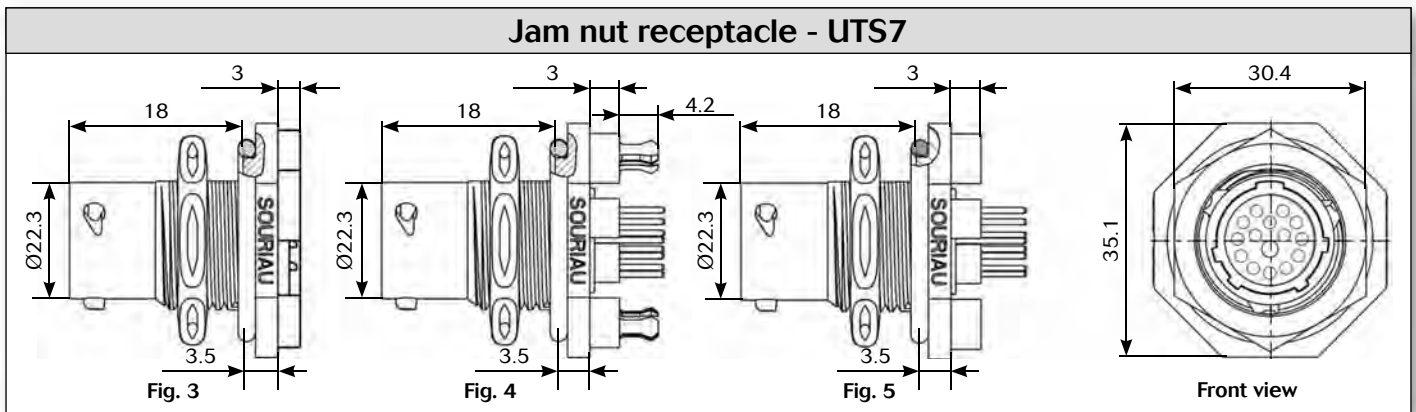
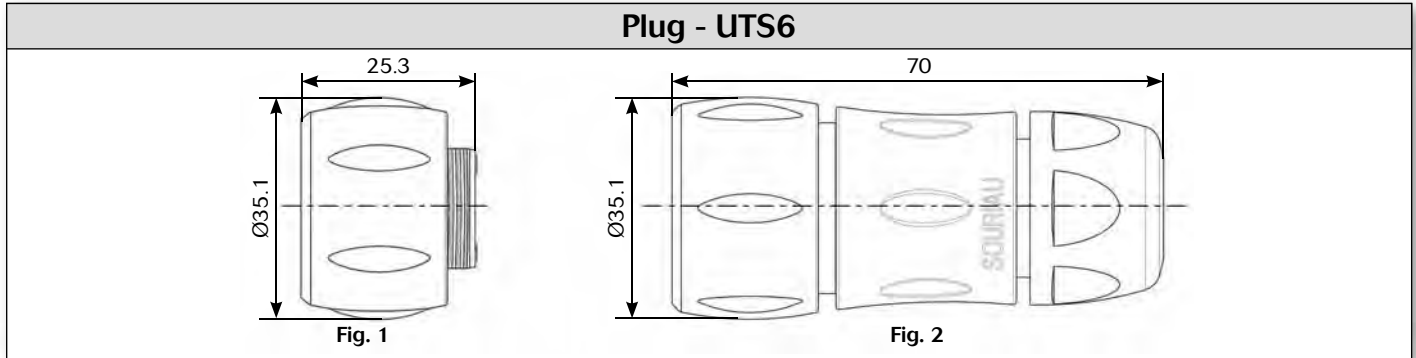



### Accessories

#### Jam nut sealing caps

Part number	Part number
UTS14DCG	UTS14DCGR

#### Plug sealing cap

Part number
UTS614DCG

#### Square flange sealing cap

Part number
UTS14DCGE

#### Plastic protective cap

Part numbers	
Receptacle cap	Plug cap
85005588A	85005597

#### Gasket

Part numbers / neoprene
UTFD14B

#### Color coding rings

Part numbers	
Receptacles	Plugs
UTS714CCR	UTS614CCR
UTS714CCRY	UTS614CCRY
UTS714CCRG	UTS614CCRG

\* Add G for Green, Y for Yellow, R for Red

#### Electrical characteristics

**UL**  
12A 650V UL94 HB

**CSA**  
12A 650V UL94 HB

**IEC**  
4A 50V 1.5kV 3

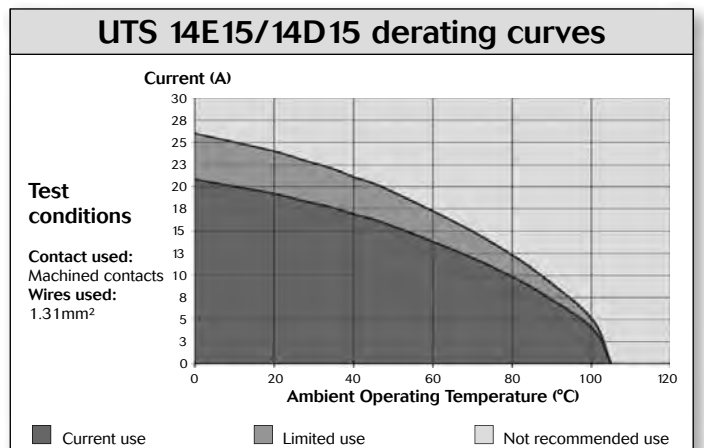

UTS Series  
14E15/14D15



# UTS Series

## 14E18/14D18

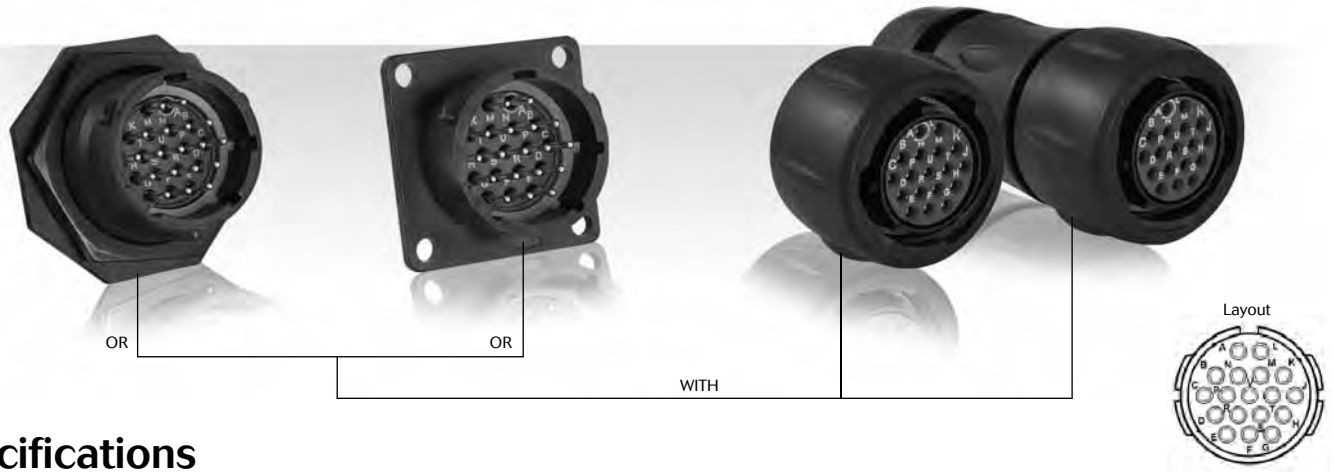

## Specifications

Contact type	Connector type	Backshell	Part number	
			Male insert	Female insert
Hand solder electrical contacts loaded	Square flange receptacle	Without (Fig.6)	UTS014E18P	UTS014E18S
	Plug	Without (Fig.1)	UTS614E18P	UTS614E18S
		Cable gland (Fig.2)	UTS6JC14E18P	UTS6JC14E18S
	Jam nut receptacle	Without (Fig.3)	UTS714E18P	UTS714E18S
PCB contacts loaded	Square flange receptacle	Without (Fig.7)	UTS014D18P	UTS014D18S
	Jam nut receptacle with stand off and with hold down clips	Without (Fig.4)	UTS714D18P32	UTS714D18S32
	Jam nut receptacle with stand off and without hold down clip	Without (Fig.5)	UTS714D18P	UTS714D18S

Sealed unmatred



### Dimensions

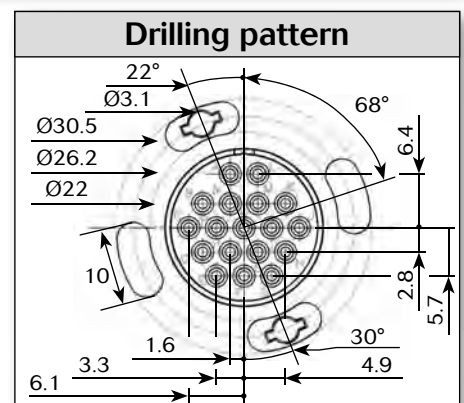
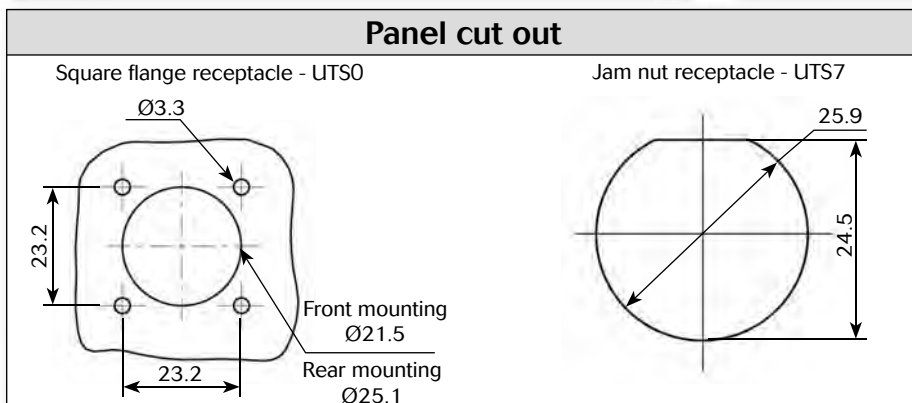
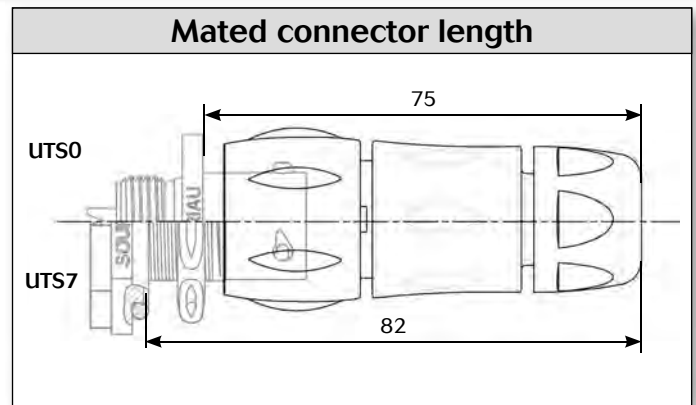
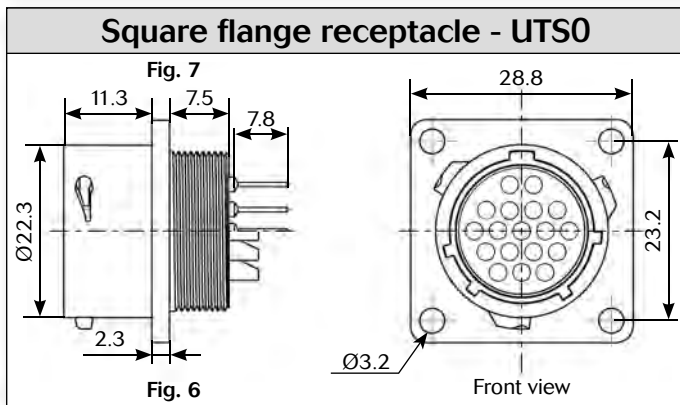
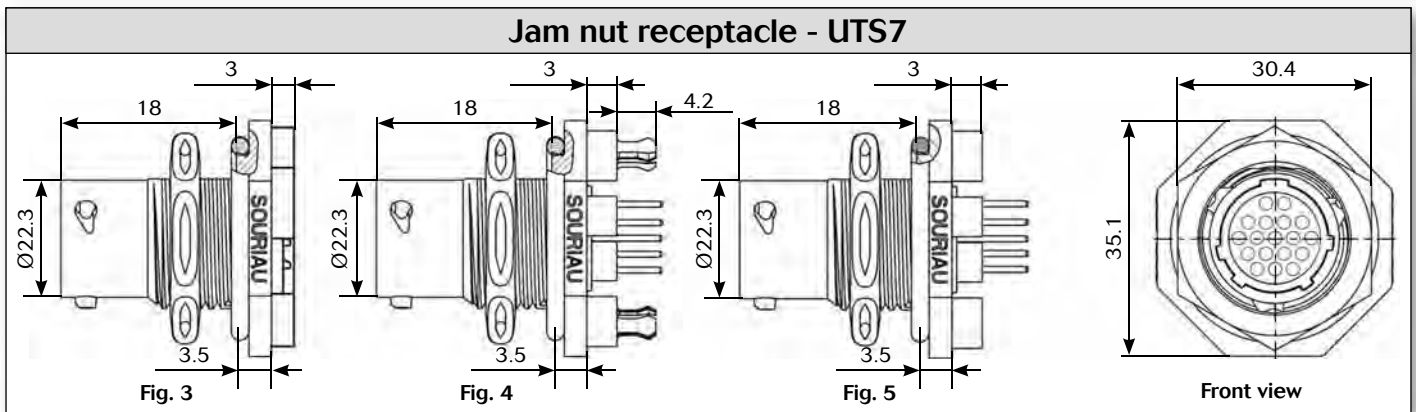
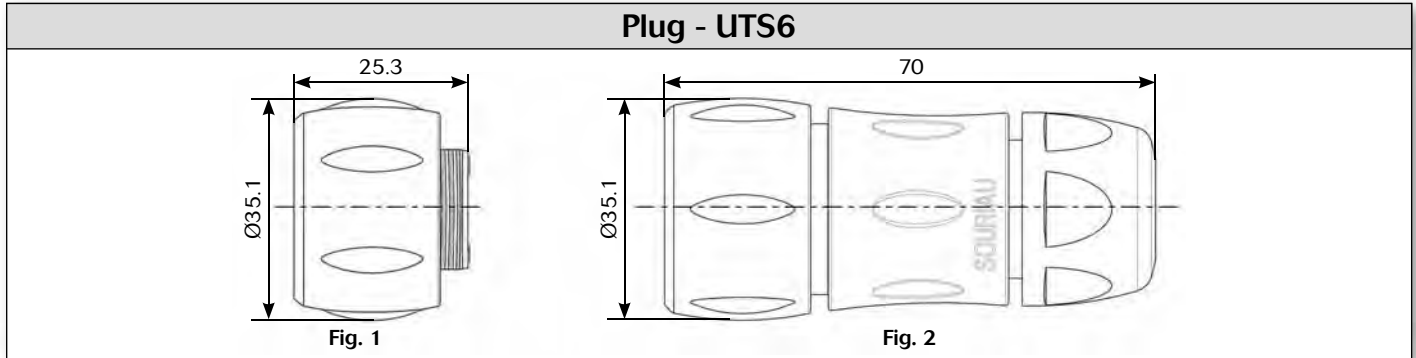

Note: all dimensions are in mm



### Accessories

#### Jam nut sealing caps

Metal terminal

Part number
UTS14DCG

Part number
UTS14DCGR

#### Plug sealing cap

Part number
UTS614DCG

#### Square flange sealing cap

Metal terminal

Part number
UTS14DCGE

#### Plastic protective cap

Part numbers	
Receptacle cap	Plug cap
85005588A	85005597

#### Gasket

Part numbers / neoprene
UTFD14B

#### Color coding rings

G for Green  
Y for Yellow  
R for Red

Part numbers	
Receptacles	Plugs
UTS714CCR	UTS614CCR
UTS714CCRY	UTS614CCRY
UTS714CCRG	UTS614CCRG

\* Add G for Green, Y for Yellow, R for Red

#### Electrical characteristics

**UL**  
4A 250V UL94 HB

**CSA**  
4A 250V UL94 HB

**IEC**  
5A 50V 1.5kV 3

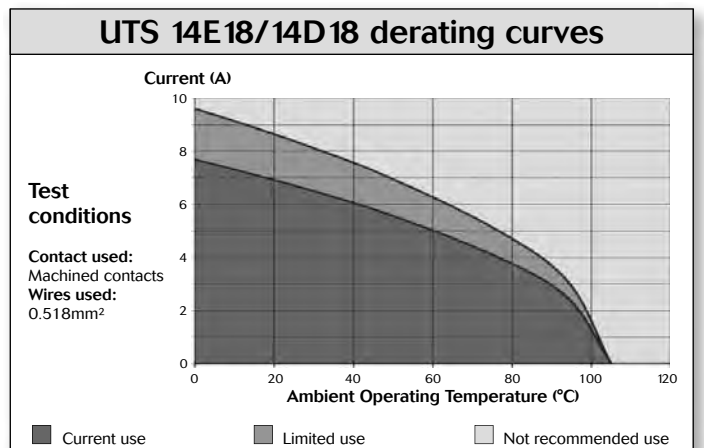

UTS Series  
14E18/14D18





# UTS Series

## 1419 - 14E19/14D19

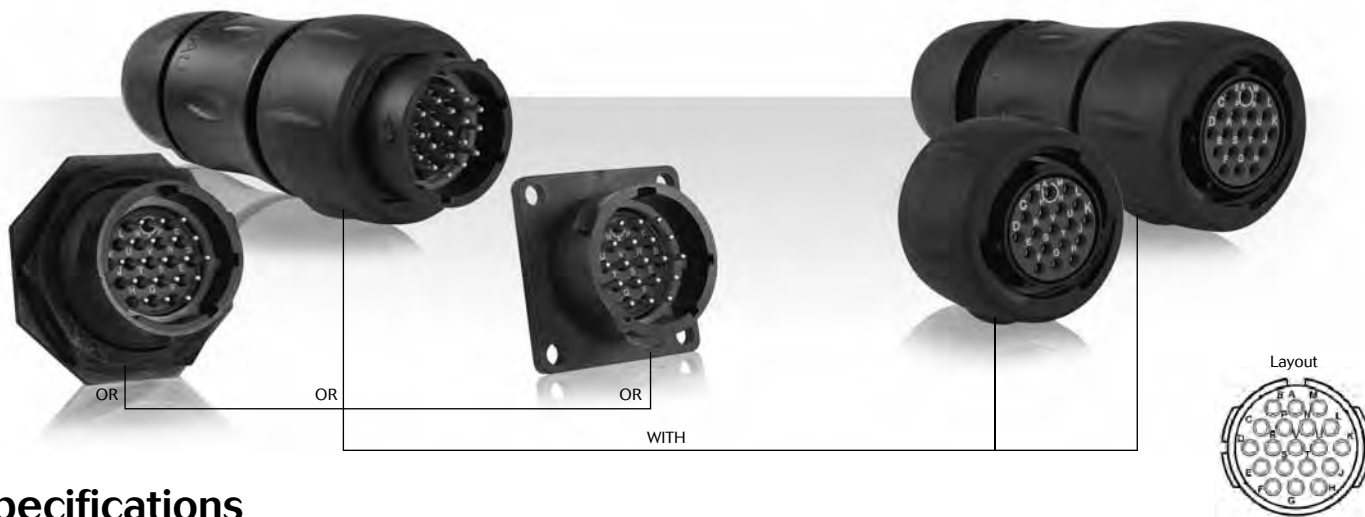

## Specifications

Contact type	Connector type	Backshell	Part number	
			Male insert	Female insert
Crimp contacts supply separately see page 131	Free hanging receptacle	Cable gland (Fig.1)	UTS1JC1419P	UTS1JC1419S
	Plug	Without (Fig.2)	UTS61419P	UTS61419S
	Plug	Cable gland (Fig.3)	UTS6JC1419P	UTS6JC1419S
	Jam nut receptacle	Without (Fig.4)	UTS71419P	UTS71419S
PCB contacts supply separately see page 131	Jam nut receptacle	Without (Fig.4)	UTS71419P	UTS71419S
Hand solder electrical contacts loaded	Square flange receptacle	Without (Fig.8)	UTS014E19P	UTS014E19S
	Plug	Without (Fig.2)	UTS614E19P	UTS614E19S
		Cable gland (Fig.3)	UTS6JC14E19P	UTS6JC14E19S
	Jam nut receptacle	Without (Fig.5)	UTS714E19P	UTS714E19S
PCB contacts loaded	Square flange receptacle	Without (Fig.9)	UTS014D19P	UTS014D19S
	Jam nut receptacle with stand off and with hold down clips	Without (Fig.6)	UTS714D19P32	UTS714D19S32
	Jam nut receptacle with stand off and without hold down clip	Without (Fig.7)	UTS714D19P	UTS714D19S

Sealed unmatred

## Square flange receptacle



### Dimensions

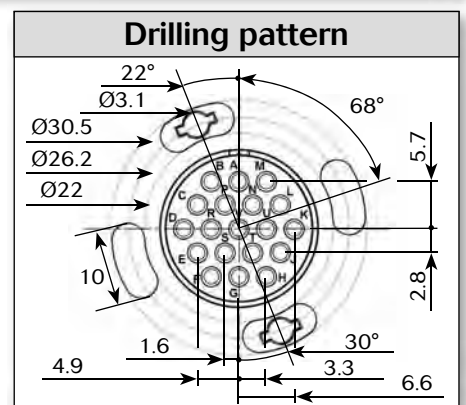
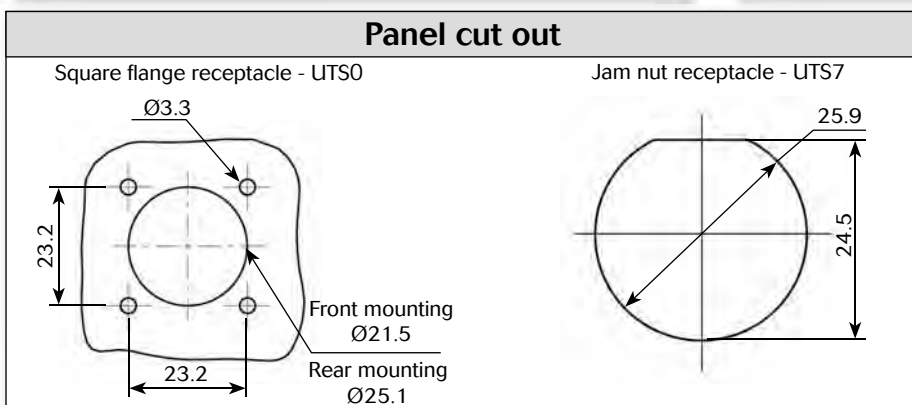
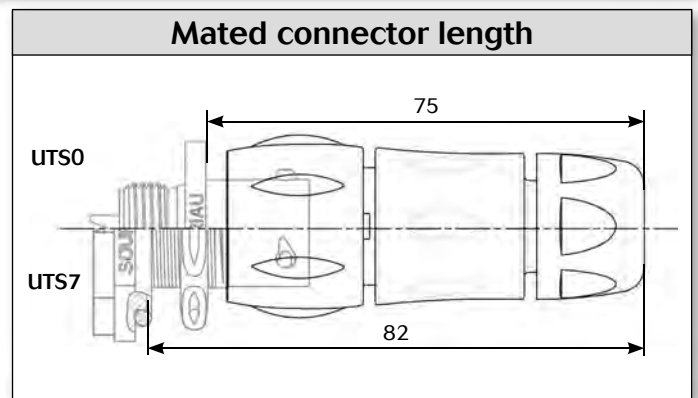
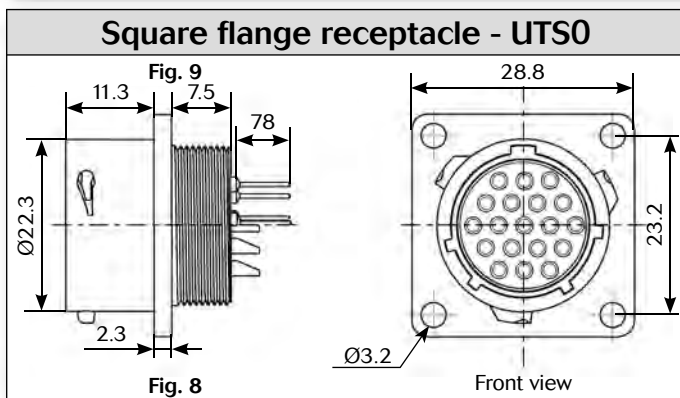
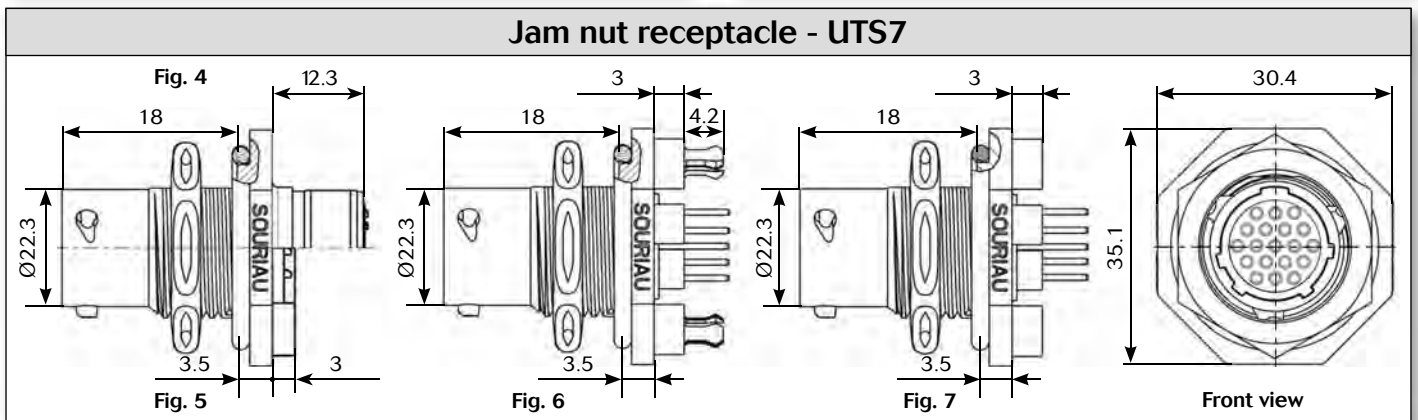
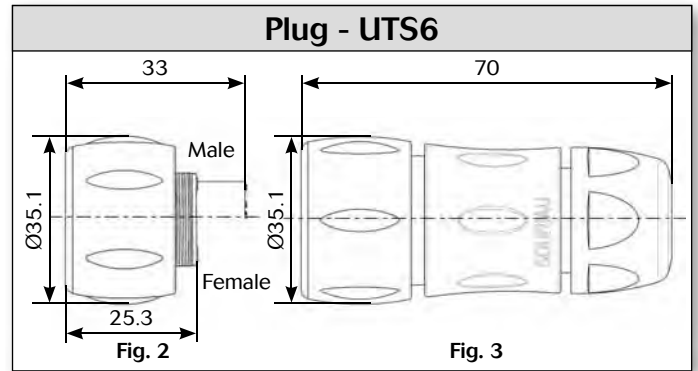
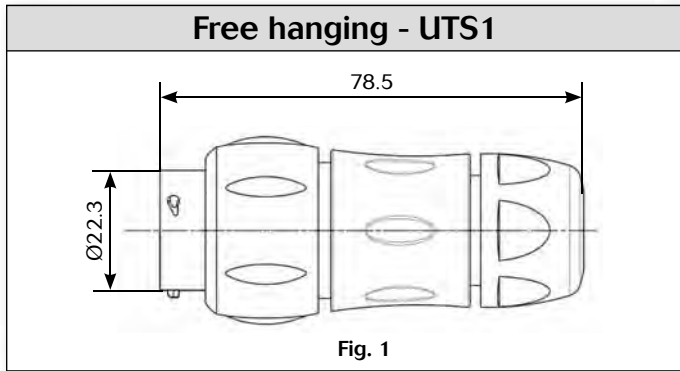



### Accessories and tooling

#### Jam nut sealing caps



Part number
UTS14DCG



Metal terminal

Part number
UTS14DCGR

#### Handle



Part number
SHANGLES

#### Tool kit



Part number
TOOLKIT

#### Plug sealing cap



Part number
UTS614DCG

#### Square flange sealing cap



Metal terminal

Part number
UTS14DCGE

#### Plastic protective cap



Part numbers	
Receptacle cap	Plug cap
85005588A	85005597

#### Gasket



Part numbers / neoprene
UTFD14B

#### Crimp tooling



Contacts	Contact size	Part number of head
RM/RC 24W3K <sup>(1)</sup>	Standard contacts #20 Ø 1mm	S20RM
RM/RC 20W3K <sup>(1)</sup>		S20RM
RM/RC 18W3K <sup>(1)</sup>		S20RM
SM/SC 24W3S <sup>(2)</sup>		S20SCM20
SM/SC 24WL3S <sup>(3)</sup>		S20SCM20
SM/SC 20W3S <sup>(2)</sup>		S20SCM20
SM/SC 20WL3S <sup>(3)</sup>		S20SCM20

(1): example of plating, for other plating see UTS catalog page 143  
 (2): contact reeled  
 (3): loose contact

#### Color coding rings

G for Green

Y for Yellow

R for Red



Part numbers	
Receptacles	Plugs
UTS714CCRR	UTS614CCRR
UTS714CCRY	UTS614CCRY
UTS714CCRG	UTS614CCRG

\* Add G for Green, Y for Yellow, R for Red

# UTS Series

## 1419 - 14E19/14D19



19 contacts  
5A/32V  
per IEC 61984

### Contacts

#20	Contact type	AWG	Part number		Max wire Ø	Max insulator Ø
			Male	Female		
Crimp	Machined	26-24	RM24W3K <sup>(1)</sup>	RC24W3K <sup>(1)</sup>	-	1.58
		22-20	RM20W3K <sup>(1)</sup>	RC20W3K <sup>(1)</sup>	-	1.58
		20-18	RM18W3K <sup>(1)</sup>	RC18W3K <sup>(1)</sup>	-	2.1
	stamped & formed reeled contacts	26-24	SM24W3TK6 <sup>(2)</sup>	SC24W3TK6 <sup>(2)</sup>	-	0.89-1.58
		26-24	SM24W3TK6 <sup>(2)</sup>	SC24W3TK6 <sup>(2)</sup>	-	0.89-1.58
		22-20	SM20W3TK6 <sup>(2)</sup>	SC20W3TK6 <sup>(2)</sup>	-	1.17-2.08
		22-20	SM20W3TK6 <sup>(2)</sup>	SC20W3TK6 <sup>(2)</sup>	-	1.17-2.08
	PCB	Machined <sup>(3)</sup>	-	RMW5016K	RCW5016K	-

(1): Example of plating, for other plating see page 143  
 (2): Loose piece contact available if putting L. Example: SM20ML1-TK6  
 (3): For dimensions see page 148

Electrical characteristics	
<b>UTS 1419</b>	<b>UTS 14E19/14D19</b>
<b>UL</b>	<b>UL</b>
5A 250V UL94 V-0	4A 250V UL94 HB
<b>CSA</b>	<b>CSA</b>
4A 250V UL94 V-0	4A 250V UL94 HB
<b>IEC</b>	
5A 32V 1.5kV 3	

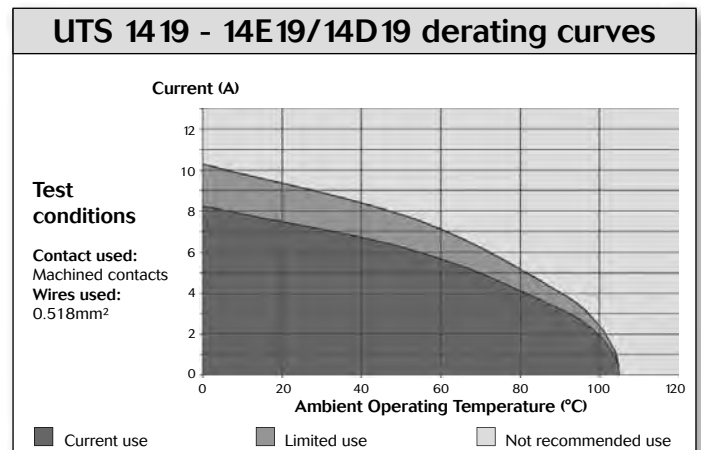

# UTS Series 1823

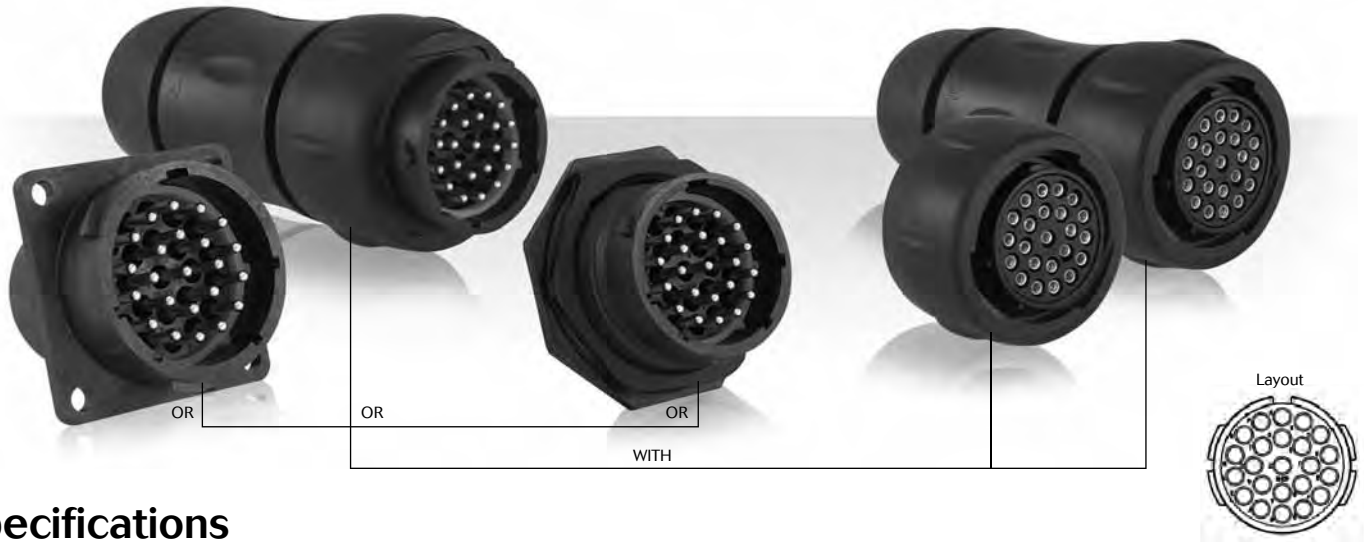

## Specifications

Contact type	Connector type	Backshell	Part number	
			Male insert	Female insert
Crimp contacts supply separately see page 135	Square flange receptacle	Without (Fig.1)	UTS01823P	UTS01823S
	Free hanging receptacle	Cable gland (Fig.2)	UTS1JC1823P	UTS1JC1823S
	Plug	Without (Fig.3)	UTS61823P	UTS61823S
	Plug	Cable gland (Fig.4)	UTS6JC1823P	UTS6JC1823S
	Jam nut receptacle	Without (Fig.5)	UTS71823P	UTS71823S
PCB contacts supply separately see page 135	Square flange receptacle	Without (Fig.1)	UTS01823P	UTS01823S
	Jam nut receptacle	Without (Fig.5)	UTS71823P	UTS71823S



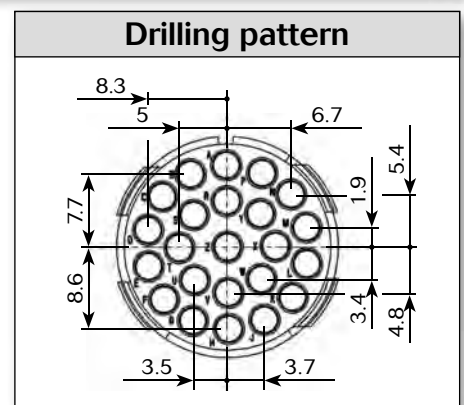
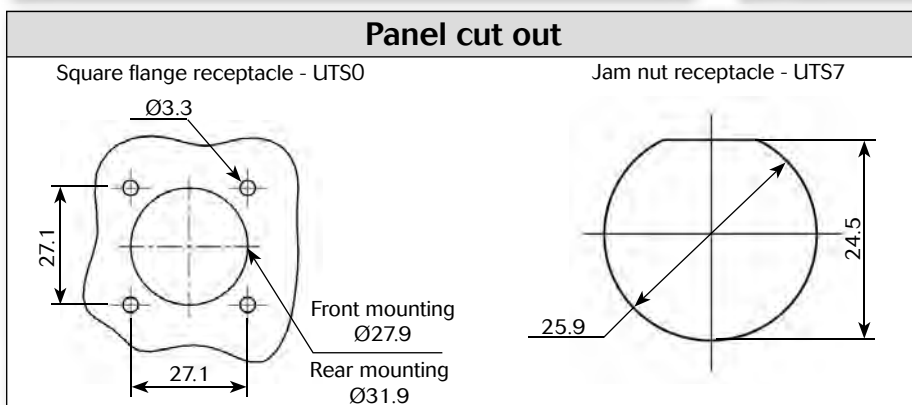
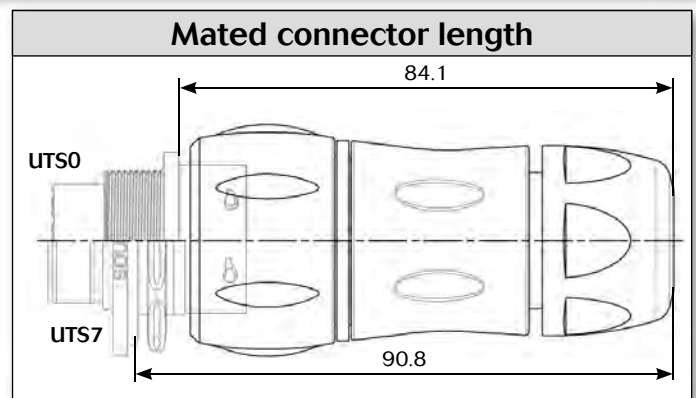
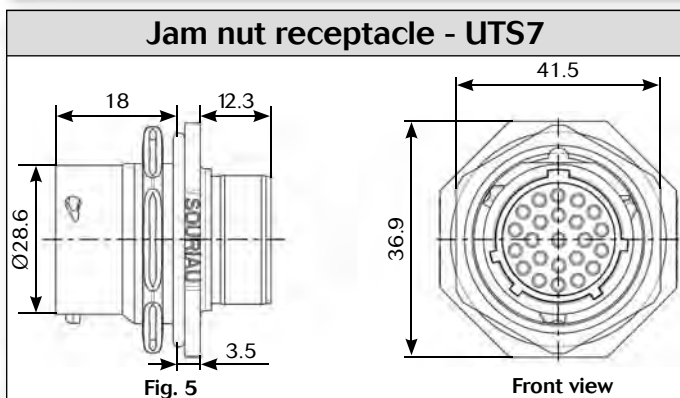
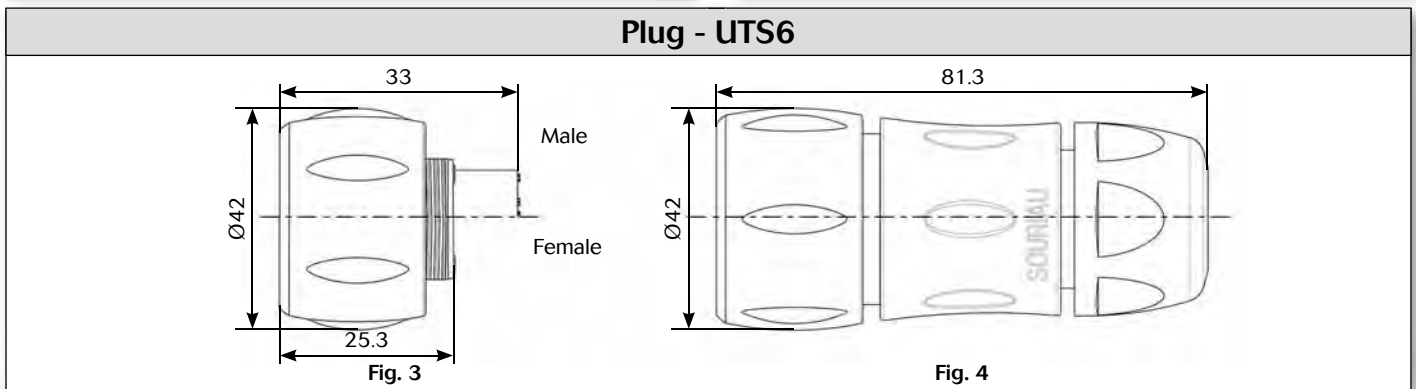
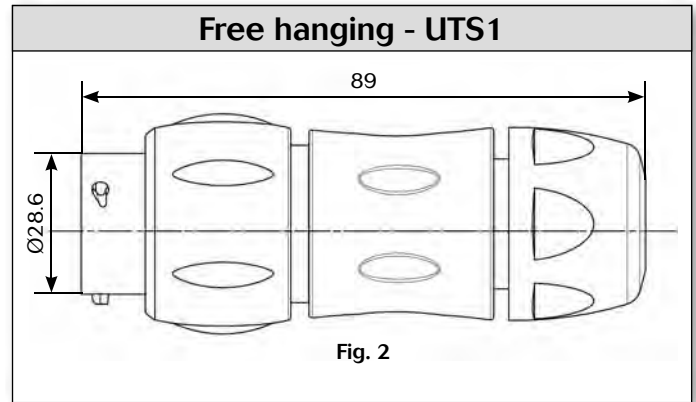
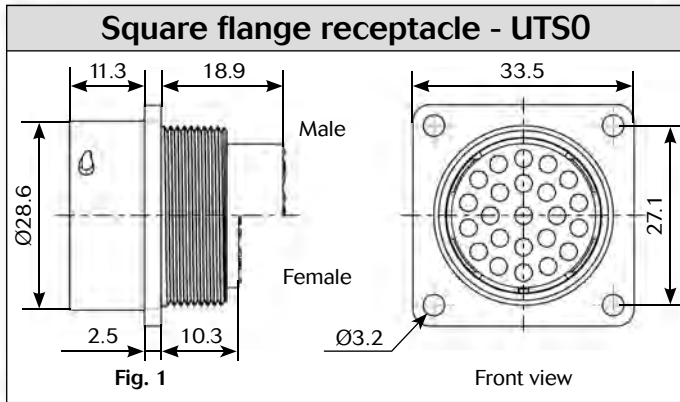

### Dimensions



Note: all dimensions are in mm



### Accessories and tooling

Jam nut sealing caps	
	
Part number	Part number
UTS18DCG	UTS18DCGR

Metal terminal

Handle

Part number
SHANDLES

Tool kit

Part number
TOOLKIT

Plug sealing cap

Part number
UTS618DCG

Square flange sealing cap

Part number
UTS18DCGE

Metal terminal

Plastic protective cap	
	
Part numbers	
Receptacle cap	Plug cap
8500-5590A	8500-5599

Gasket

Part numbers / neoprene
UTFD16B

Crimp tooling			
			
Contacts	Contact size	Part number of head	
RM/RC 28M1K <sup>(1)</sup>	Standard contacts #16 Ø 1.6mm	S16RCM20	
RM/RC 24M9K <sup>(1)</sup>		S16RCM20	
RM/RC 20M13K <sup>(1)</sup>		S16RCM20	
RM/RC 20M12K <sup>(1)</sup>		S16RCM20	
RM/RC 16M23K <sup>(1)</sup>		S16RCM16	
RM/RC 14M50K <sup>(1)</sup>		S16RCM1450	
RM/RC 14M30K <sup>(1)</sup>		S16RCM14	
SM/SC 24ML1TK6 <sup>(1)</sup>		S16SCM20	
SM/SC 20ML1TK6 <sup>(1)</sup>		S16SCM20	
SM/SC 16ML1TK6 <sup>(1)</sup>		S16SCML1	
SM/SC 14ML1TK6 <sup>(1)</sup>		S16SCML1	
SM/SC 16ML1TK6 <sup>(1)</sup>		S16SCML11	
RMDXK10D28K		Coaxial contacts	M10S-1J
RCDXK1D28K			M10S-1J
RM/RC DX60xxD28K	M10S-1J		
RM/RC DXK10D28 + york090	M10S-1J		
RM/RC DX60xxD28	M10S-1J		

(1): example of plating, for other plating see UTS catalog page 143



### Contacts

#16	Contact type	AWG	Part number		Max wire Ø	Max insulator Ø
			Male	Female		
Crimp	Machined	30-28	RM28M1K <sup>(1)</sup>	RC28M1K <sup>(1)</sup>	0.55	1.1
		26-24	RM24M9K <sup>(1)</sup>	RC24M9K <sup>(1)</sup>	0.8	1.6
		22-20	RM20M13K <sup>(1)</sup>	RC20M13K <sup>(1)</sup>	1.18	1.8
		22-20	RM20M12K <sup>(1)</sup>	RC20M12K <sup>(1)</sup>	1.18	2.2
		20-16	RM16M23K <sup>(1)</sup>	RC16M23K <sup>(1)</sup>	1.8	3.2
		16-14	RM14M50K <sup>(1)</sup>	RC14M50K <sup>(1)</sup>	2.05	3.2
		16-14	RM14M30K <sup>(1)</sup>	RC14M30K <sup>(1)</sup>	2.28	3.2
	Stamped & formed reeled contacts	26-24	SM24M1TK6 <sup>(1)(2)</sup>	SC24M1TK6 <sup>(1)(2)</sup>	0.89-1.28	-
		22-20	SM20M1TK6 <sup>(1)(2)</sup>	SC20M1TK6 <sup>(1)(2)</sup>	1.17-2.08	-
		18-16	SM16M1TK6 <sup>(1)(2)</sup>	SC16M1TK6 <sup>(1)(2)</sup>	3.0	-
18-16		SM16M11TK6 <sup>(1)(2)</sup>	SC16M11TK6 <sup>(1)(2)</sup>	2.0-3.0	-	
14		SM14M1TK6 <sup>(1)(2)</sup>	SC14M1TK6 <sup>(1)(2)</sup>	3.2	-	
PCB	Machined <sup>(3)</sup>	-	RM20M12E8K <sup>(1)</sup>	RC20M12E84K <sup>(1)</sup>	-	-
Coaxial	Cable Multipiece	-	RMDXK10D28	RCDXK1D28	-	-
	Cable Monocrimp	-	RMDX60xxD28	RCDX60xxD28	-	-
	Twisted pair Multipiece	-	RMDXK10D28 + york090	RCDXK1D28 + york090	-	-
	Twisted pair Monocrimp	-	RMDX60xxD28	RCDX60xxD28	-	-
Fiber optic	POF contacts Plastic optical fibre	-	RMPOF1000	RCPOF1000B	-	-

(1): Example of plating, for other plating see page 143  
 (2): Loose piece contact available if putting L. Example: SM20ML1-TK6  
 (3): For dimensions see page 148

Electrical characteristics
<p><b>UL</b> 10A 500V UL94 V-0</p> <p><b>CSA</b> 7A 500V UL94 V-0</p> <p><b>IEC</b> 9A 63V 1.5kV 3</p>

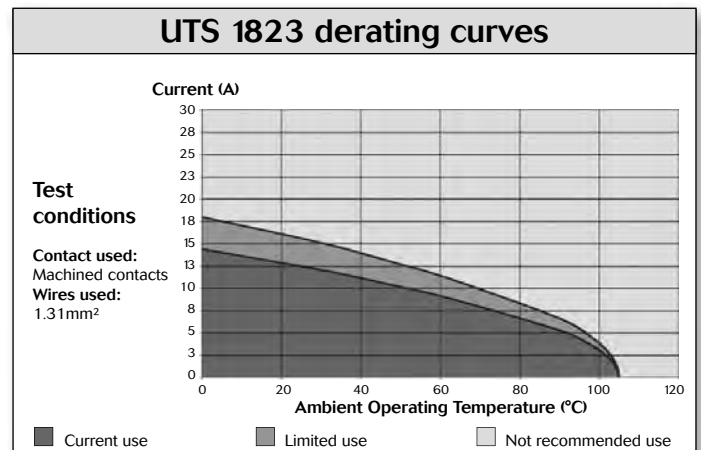



# UTS Series 1832

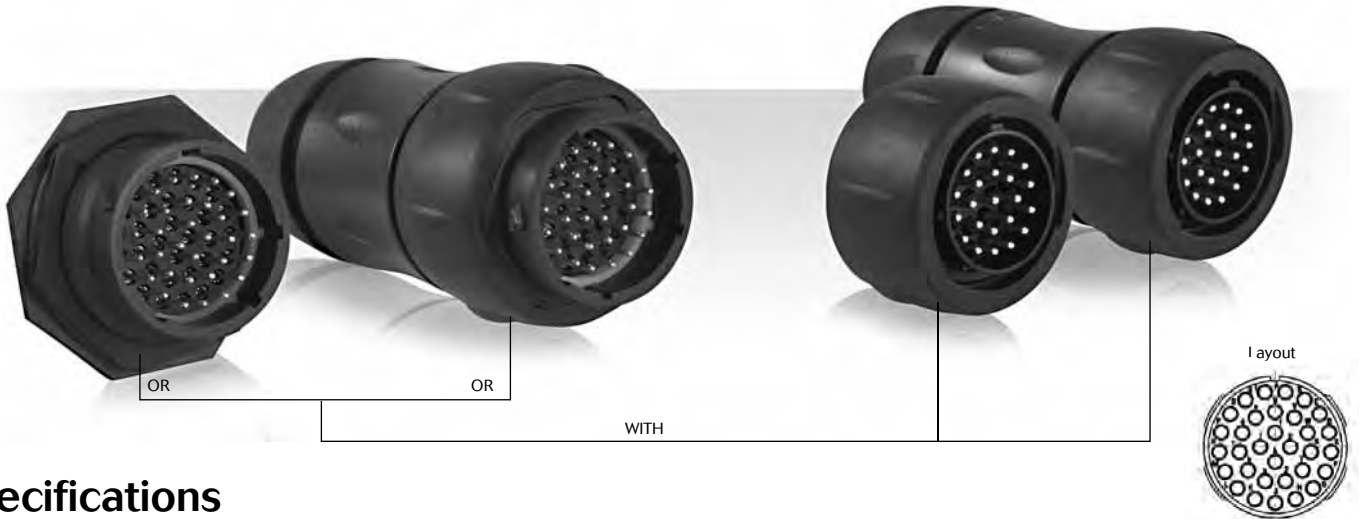

## Specifications

Contact type	Connector type	Backshell	Part number	
			Male insert	Female insert
Crimp contact supply separately see page 139	Free hanging receptacle	Cable gland (Fig.1)	UTS1JC1832P	UTS1JC1832S
	Plug	Without (Fig.2)	UTS61832P	UTS61832S
	Plug	Cable gland (Fig.3)	UTS6JC1832P	UTS6JC1832S
	Jam nut receptacle	Without (Fig.4)	UTS71832P	UTS71832S
PCB contacts supply separately see page 139	Jam nut receptacle	Without (Fig.4)	UTS71832P	UTS71832S



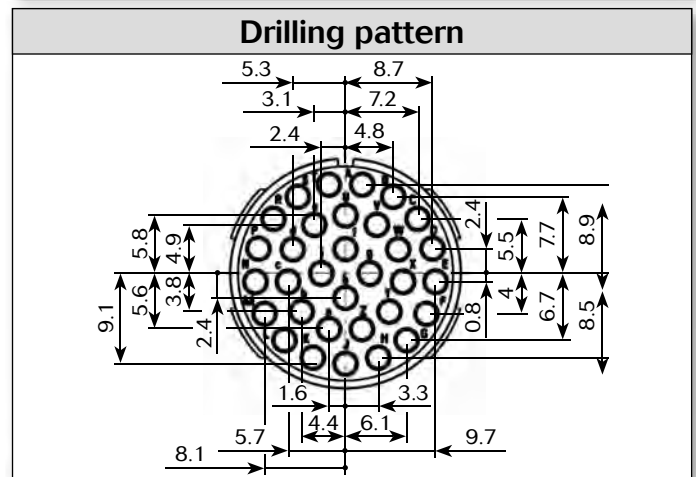
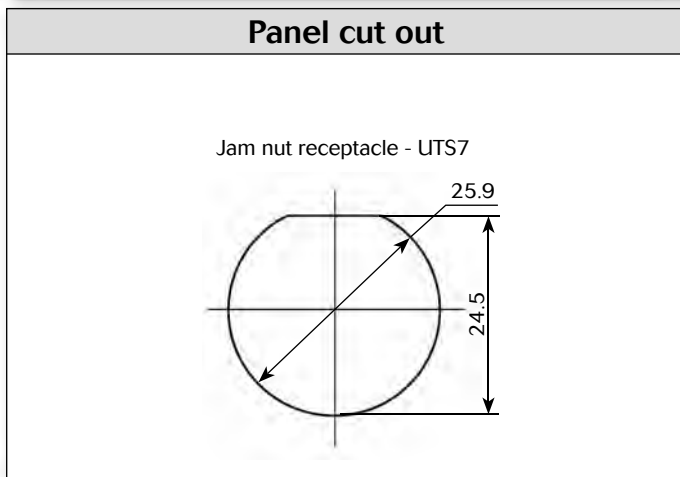
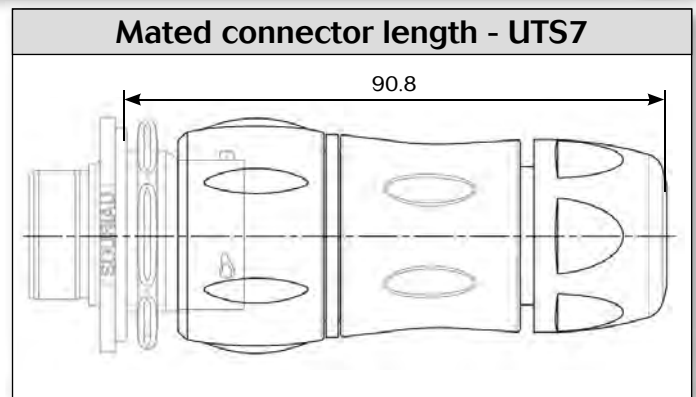
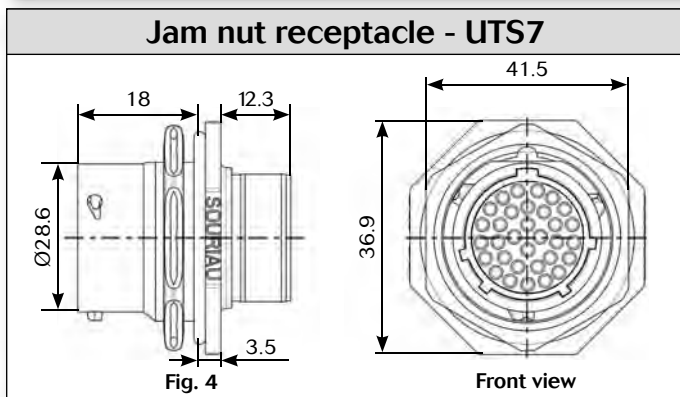
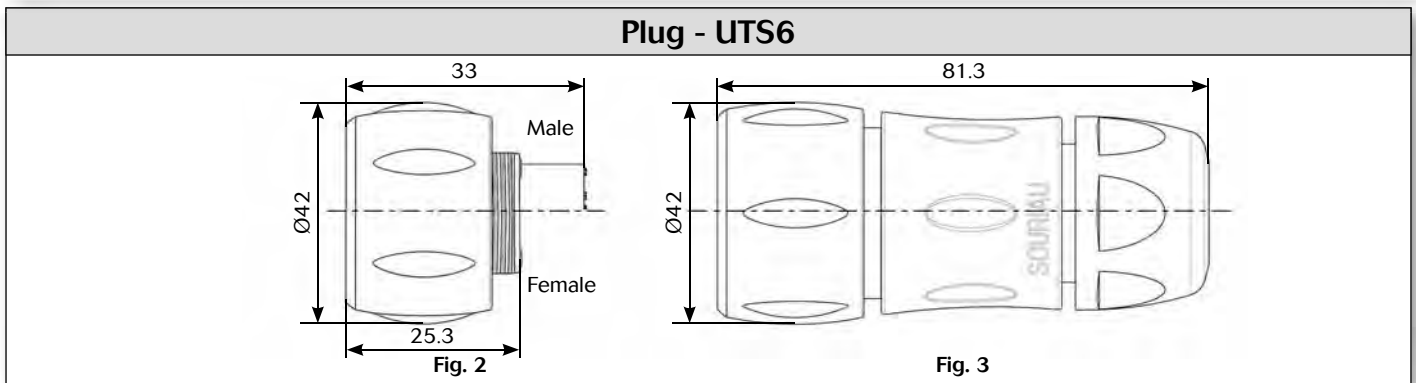
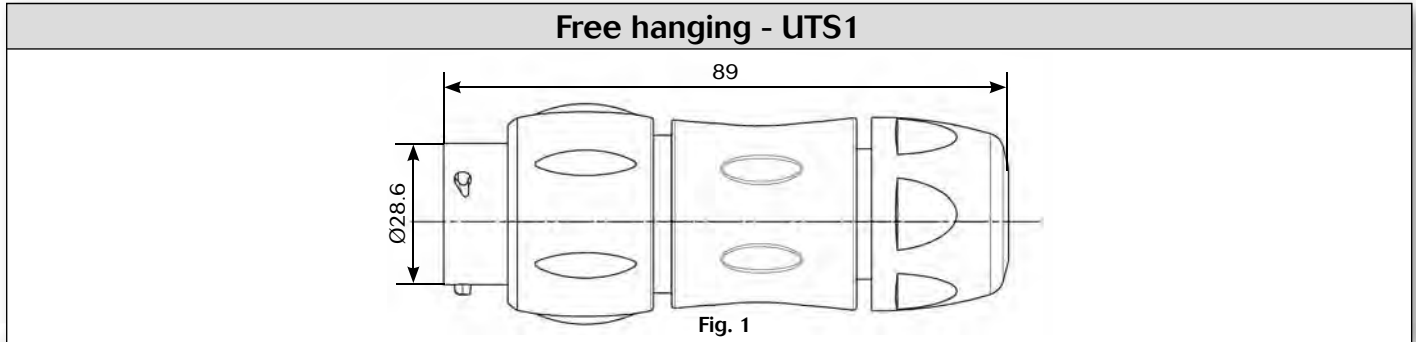

### Dimensions



Note: all dimensions are in mm



### Accessories and tooling

Jam nut sealing caps	
	
Part number	Part number
UTS18DCG	UTS18DCGR

Metal terminal

Handle

Part number
SHANDLES

Tool kit

Part number
TOOLKIT

Plug sealing cap

Part number
UTS618DCG

Square flange sealing cap

Part number
UTS18DCGE

Metal terminal

Crimp tooling		
		
Contacts	Contact size	Part number of head
RM/RC 24W3K <sup>(1)</sup>	Standard contacts #20 Ø 1mm	S2ORM
RM/RC 20W3K <sup>(1)</sup>		S2ORM
RM/RC 18W3K <sup>(1)</sup>		S2ORM
SM/SC 24W3S <sup>(2)</sup>		S20SCM20
SM/SC 24WL3S <sup>(3)</sup>		S20SCM20
SM/SC 20W3S <sup>(2)</sup>		S20SCM20
SM/SC 20WL3S <sup>(3)</sup>		S20SCM20

(1): example of plating, for other plating see UTS catalog page 143  
 (2): contact reeled  
 (3): loose contact

Plastic protective cap	
	
Part numbers	
Receptacle cap	Plug cap
8500-5590A	8500-5599

Gasket

Part numbers / neoprene
UTFD16B



### Contacts

#20	Contact type	AWG	Part number		Max wire Ø	Max insulator Ø
			Male	Female		
Crimp	Machined	26-24	RM24W3K <sup>(1)</sup>	RC24W3K <sup>(1)</sup>	-	1.58
		22-20	RM20W3K <sup>(1)</sup>	RC20W3K <sup>(1)</sup>	-	1.58
		20-18	RM18W3K <sup>(1)</sup>	RC18W3K <sup>(1)</sup>	-	2.1
	stamped & formed reeled contacts	26-24	SM24W3TK6 <sup>(2)</sup>	SC24W3TK6 <sup>(2)</sup>	-	0.89-1.58
		26-24	SM24W3TK6 <sup>(2)</sup>	SC24W3TK6 <sup>(2)</sup>	-	0.89-1.58
		22-20	SM20W3TK6 <sup>(2)</sup>	SC20W3TK6 <sup>(2)</sup>	-	1.17-2.08
		22-20	SM20W3TK6 <sup>(2)</sup>	SC20W3TK6 <sup>(2)</sup>	-	1.17-2.08
	PCB	Machined <sup>(3)</sup>	-	RMW5016K	RCW5016K	-

(1): Example of plating, for other plating see page 143  
 (2): Loose piece contact available if putting L. Example: SM20ML1-TK6  
 (3): For dimensions see page 148

Electrical characteristics
<p><b>UL</b> 5A 250V UL94 V-0</p> <p><b>CSA</b> 4A 250V UL94 V-0</p> <p><b>IEC</b> 4A 32V 1.5kV 3</p>

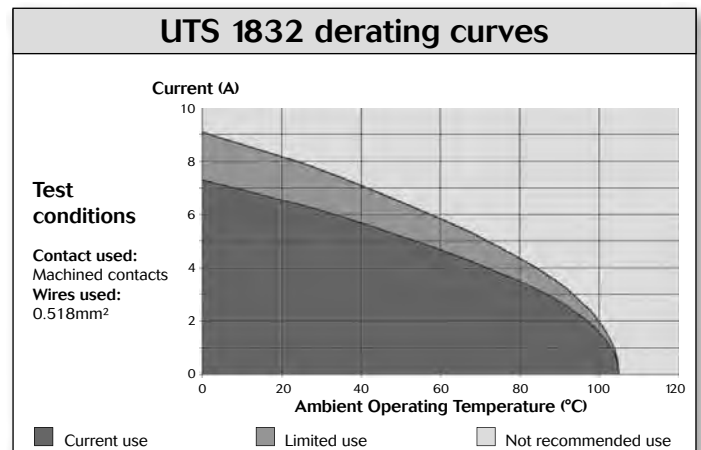



QUIT'S SERIES

# Contacts

- Description ..... 142
- Contact plating selector guide ..... 143
- Contact selector guide ..... 144
- Packaging ..... 144
- Crimp contacts ..... 145
- #16 coaxial contacts ..... 147
- PCB contacts ..... 148
- Fibre optic contacts ..... 149



## Contacts



### Description

The UTS series is delivered with (solder and PCB versions) or without contact (crimp version). When contacts are not loaded, this series offers the unique possibility to use the same contact in any layout as long as it receives the same active part size. Thus it is possible to buy only one contact reference and equip all connectors even if housings are different.

The main benefit is the standardisation which means reduction of inventory cost.

Bearing in mind that any additional tool or complicated assembly process should be avoided, our contacts are based on a snap-in principle which avoid the use of an insertion tool.

Crimp contacts are available in different versions:



• machined



• stamped & formed



• coaxial



• fiber optic

In addition, UTS series can obviously be equipped with solder contacts, PCB contacts, screw termination.



## Contact plating selector guide

As soon as you know what contact size you need, you next have to decide on which type to use.

Souriau proposes mainly two different types of electrical contacts:

- Machined
- Stamped & formed

Machined contacts are generally chosen for low quantities purpose as well as a better solution for power applications.

Stamped & formed contacts offer the ability to be crimped automatically which makes them more suitable for high volume production applications.

Then comes the question: What plating should I choose ?

Hereunder is a graph with criteria to guide you:

*NB: do not mix different plating (e.g. tin plated pin contact with gold plated socket contact).*

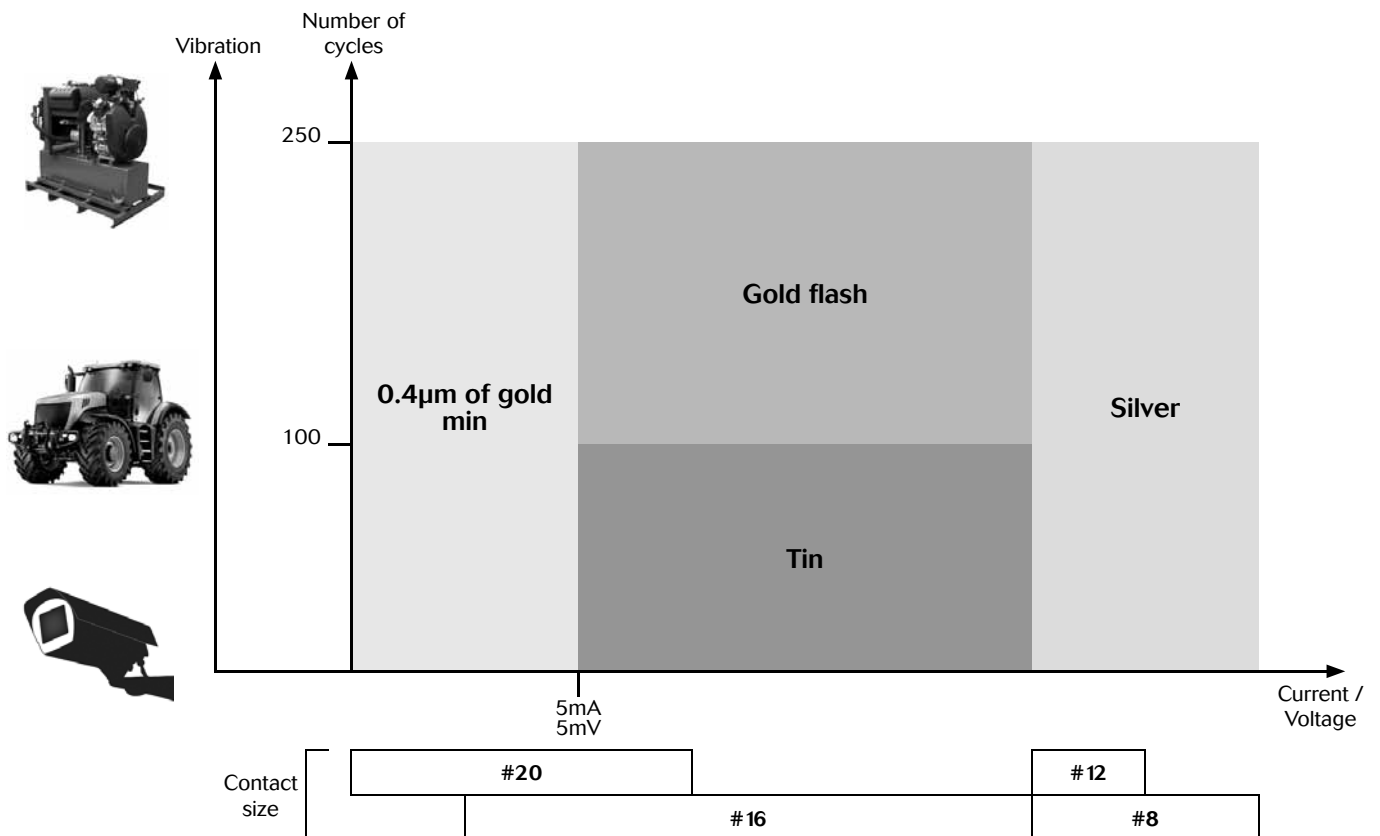



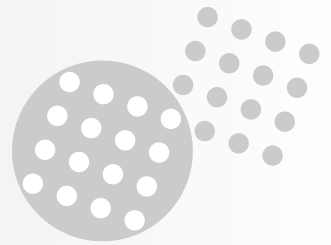

## Contact selector guide

### Contact preloaded

Electrical characteristics: contact resistance		
#20 Ø1mm	Machined	< 4mΩ
#16 Ø1.6mm	Machined	< 3mΩ

Available platings (contact preloaded)
Min 0.4μ gold over 2μ Ni

### Contact supply separately

Electrical characteristics: contact resistance		
#20 Ø1mm	Machined	< 6mΩ
	Stamped & formed	< 15mΩ
#16 Ø1.6mm	Machined	< 3mΩ
	Stamped & formed	< 6mΩ
#12 Ø2.4mm	Machined	< 5mΩ
#8 Ø3.6mm	Machined	< 5mΩ

Available platings (contact supply separately)	
A	2μ Ni + 2μ Ag
J	Gold flash over 2μ Ni
K	Min 0.4μ gold over 2μ Ni
S31	Active part: Gold flash over Ni Crimp area: Nickel
S18	Active part: 0.75μ gold min over 2μ Ni Crimp area: 1.3μ tin over Ni Other: Nickel
S25 S26	Active part: 0.75μ Au over Ni Crimp area: flash Au over Ni
TK6	2-5μ Sn pre-plated

## Packaging

Conscious of the wide variety of applications, contact packaging has been considered for small series (bulk packaging) and high volume production (reeled contacts):

### Size contacts #20 & #16



- 25 pieces bulk packing (stamped & formed contacts)



- 50 pieces bulk packing (machined contacts)



- 1000 pieces bulk packing (machined contacts)



- 3000 pieces reeled (stamped & formed contacts)



- 5000 pieces reeled (machined contacts)

### Size contacts #12 & #8



- 100 pieces bulk packing (stamped & formed contacts)

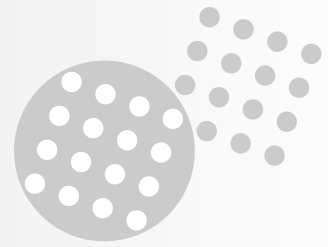

## Crimp contacts

### Standard version



Contact size	Type	Wire size		Part number		Max wire Ø	Max insulator Ø	Plating available
		AWG	mm <sup>2</sup>	Male	Female			
#20 Ø1 mm	Machined	26-24	0.13-0.20	RM24W3K	RC24W3K		1.58 max	K
	Stamped & Formed	26-24	0.13-0.25	SM24W3-(1)	SC24W3-(1)		0.89-1.58	TK6 S25 (female) S26 (male)
				SM24WL3-(2)	SC24WL3-(2)			
	Machined	22-20	0.32-0.52	RM20W3K	RC20W3K		1.58 max	K
	Stamped & Formed	22-20	0.35-0.5	SM20W3-(1)	SC20W3-(1)		1.17-2.08	TK6 S25 (female) S26 (male)
SM20WL3-(2)				SC20WL3-(2)				
Machined	20-18	0.50-0.93	RM18W3K	RC18W3K		2.10 max	K	
#16 Ø1.6 mm	Machined	30-28	0.05-0.08	RM28M1-	RC28M1-	0.55	1.1	K, J
	Machined	26-24	0.13-0.2	RM24M9-	RC24M9-	0.8	1.6	K, J
	Stamped & Formed	26-24	0.13-0.25	SM24M1-(1)	SC24M1-(1)	0.89-1.28	Insulation grip	S31, S18, TK6
				SM24ML1-(2)	SC24ML1-(2)			
	Machined	22-20	0.32-0.52	RM20M13-	RC20M13-	1.18	1.8	K, J
				RM20M12-	RC20M12-		2.2	
	Stamped & Formed	22-20	0.35-0.5	SM20M1-(1)	SC20M1-(1)	1.17-2.08	Insulation grip	S31, S18, TK6
				SM20ML1-(2)	SC20ML1-(2)			
	Machined	20-16	0.52-1.5	RM16M23-	RC16M23-	1.8	3.2	K, J
	Stamped & Formed	18-16	0.8-1.5	SM16M1-(1)	SC16M1-(1)	3.0	No insulation grip	S31, S18, TK6
				SM16ML1-(2)	SC16ML1-(2)			
Stamped & Formed	18-16	0.8-1.5	SM16M11-(1)	SC16M11-(1)	2.0-3.0	Insulation grip	S31, S18, TK6	
			SM16ML11-(2)	SC16ML11-(2)				
Machined	16-14	1.5-2.5	RM14M50-	RC14M50-	2.05	3.2	K, J	
Machined	16-14	1.5-2.5	RM14M30-	RC14M30-	2.28	3.2	K, J	
Stamped & Formed	14	2.0-2.5	SM14M1-(1)	SC14M1-(1)	3.2	No insulation grip	S31, S18, TK6	
			SM14ML1-(2)	SC14ML1-(2)				
#12 Ø2.4 mm	Machined	22	0.13-0.4	82911457NA	82911456A	-	4.9	A, K
		20	0.5	82911459NA	82911458A			
		18	0.75-1.0	82911461NA	82911460A			
		16	1.5	82911463NA	82911462A			
		14	2.5	82911465NA	82911464A			
		12	4	82911467NA	82911466A			
#8 Ø3.6 mm	Machined	16	1.5	82913601A	82913600A	-	6.5	A
		14	2.5	82913603A	82913602A			
		12	4	82913605A	82913604A			
		10	6.0	82913607A	82913606A			
		8	10.0	82913609A	82913608A			

(1) contact reeled (2) loose contact

Example: RM24W3K - Size #20, Machined, AWG24 wire.



## Crimp contacts

### First Mate Last Break contacts

Contact size	Type	Wire size		Part number		Max wire Ø	Max insulator Ø	Color band		Plating available
		AWG	mm <sup>2</sup>	Male	Female			Front	Rear	
# 16 Ø1.6 mm Longer male contact (+1mm)	Machined	30-28	0.05-0.08	RM28M1GE1□	-	0.55	1.1	-	Red	□ = K, J
		26-24	0.13-0.2	RM24M9GE1□		0.8	1.6	Red	Red	
		22-20	0.32-0.52	RM20M13GE1□		1.18	1.8	Black	Red	
				RM20M12GE1□			2.2	Blue	Red	
		20-16	0.52-1.5	RM16M23GE1□		1.8	3.2	-	Red	
		16-14	1.5-2.5	RM14M50GE1□		2.05	-	-	Red	
16-14	1.5-2.5	RM14M30GE1□	2.28	-	-	Red				
# 16 Ø1.6 mm Shorter female contact (-0.7mm)	Machined	30-28	0.05-0.08	-	RC28M1GE7□	0.55	1.1	-	Blue	□ = K, J
		26-24	0.13-0.2		RC24M9GE7□	0.8	1.6	Red	Blue	
		22-20	0.32-0.52		RC20M13GE7□	1.18	1.8	Black	Blue	
					RC20M12GE7□		2.2	Blue	Blue	
		20-16	0.52-1.5		RC16M23GE7□	1.8	3.2	-	Blue	
		16-14	1.5-2.5		RC14M50GE7□	2.05	-	-	Blue	
16-14	1.5-2.5	RC14M30GE7□	2.28	-	-	Blue				

Example: RM16M3GE1K - Size #16, Machined, Longer male, AWG16 wire.

### How to make FMLB / LMFB connection

Contact 1 \ Contact 2	Standard male contact	Standard female contact	Longer male contact
Standard male contact		✓	
Standard female contact	✓		✓ FMLB
Shorter female contact	✓ LMFB		

First Mate Last Break contacts should be chosen only if the cavity is not marked with the earth symbol. For cavities marked with the earth symbol, standard contacts will fulfill the same role as a first mate, last break contact used in a standard cavity.



Ground symbol



## #16 coaxial contacts

### Coaxial contact range

We provide 2 types of coaxial contacts suitable for 50 or 75Ω, coaxial cable or twisted pair cable.

#### Monocrimp coaxial contact

- The monocrimp one-piece coaxial contacts offer high reliability plus the economic advantage of a 95% reduction in installation time over conventional assembly methods.
- This economy is achieved by simultaneously crimping both the inner conductor and outer braid or drain wire.



#### Multipiece crimp coaxial contact

- The inner conductor and outer braid is crimped individually.
- The thermoplastic insulating bushing in the outer body is designed to accept and permanently retain the inner contact.
- An outer ferrule is used to connect the braid to the outer contact and provide cable support to ensure against bending and vibration.



#### Suitable for Coaxial cable or Twisted cable

- For jacket diameter from 1.78 to 3.05mm  
Inner conductor up to 2.44mm diameter



- For jacket diameter from 0.64 to 1.45mm  
Inner conductor from AWG30 to AWG24

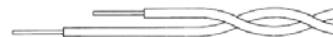

#### Contacts for coaxial cable summary

Contact type	Contact range		Contact part number with cable combination	Cabling notice
	Male contact	Female contact		
Multipiece	RMDXK10D28	RCDXK1D28	See page 176	See pages 180 & 181
Monocrimp	RMDX60xxD28	RCDX60xxD28		See page 182

#### Contacts for twisted pairs cable summary

Contact type	Contact range		Contact part number with cable combination	Cabling notice
	Male contact	Female contact		
Multipiece	RMDXK10D28 + YORK090	RCDXK1D28 + YORK090	See page 177	See page 178
Monocrimp	RMDX60xxD28	RCDX60xxD28		See page 179



## PCB contacts

### PCB contacts

#### PCB soldering

UTS range can be carried out with a wave soldering process, but not reflow soldering process.  
All high temperature processes are prohibited.



Contact size	Type	Part number		Plating
		Male	Female	
#20 Ø1 mm	Short version	RMW50A7K	RCW50A7K	K
	Long version	RMW5016K	RCW5016K	
#16 Ø1.6 mm	Short version	RM20M12E8K	RC20M12E8K	K
	Long version	RM20M12E83K	RC20M12E83K	
			RC20M12E84K	

Exemple: RM50A7K - Size #20, Short version, male.

#### Nominal length (G)

Dimension of dipsolder contacts out of connector (contacts to be ordered separately).

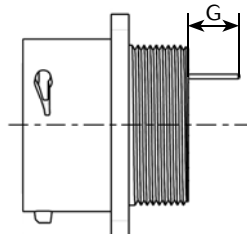

#### UTS0

Connector size	Pin contact		Socket contact		
	RM20M12E8*□	RM20M12E83*□	RC20M12E8*□	RC20M12E83*□	RC20M12E84*□
10	4	9.1	3.3	8.5	12.1
12	4	9.1	3.3	8.5	12.1
14	4	9.1	3.3	8.5	12.1
16	4	9.1	3.3	8.5	12.1

#### UTS7

Connector size	Pin contact				Socket contact			
	RM20M12E8*□	RM20M12E83*□	RMW50A7K	RMW5016K	RC20M12E8*□	RC20M12E83*□	RCW50A7K	RCW5016K
10	4.1	9.2	9.51	10.41	4.65	8.5	2.4	3.04
12	4	9.2	9.51	10.41	3.3	8.5	2.4	3.04
14	4	9.2	9.51	10.41	3.3	8.5	2.4	3.04
16	4	9.2	9.51	10.41	3.3	8.5	2.4	3.04

\* Plating indication: see plating table

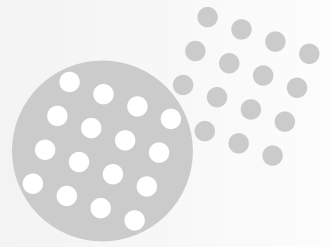

## Fibre optic contacts

### Description

#### Size 16 Fibre optic contacts for TRIM TRIO® connectors

Size 16 Fibre optic contacts are optical contacts designed for the integration of optical links in all TRIM TRIO® cable connectors.

The Fibre optic contacts are designed to accommodate:

- Plastic Optical Fibre (POF)
  - 1 mm core and 2.2 mm jacket
- Plastic Clad Fibre (PCF)
  - 230µm core and 2.2 mm jacket

Typical features and benefits are:

- Socket contact is spring loaded to avoid any air gap between the two optical faces.
- Low insertion loss is provided by high precision pieces.
- Single jumpers, multiway harness and active device housings can be supplied regarding customer requirement.



### Technical characteristics

#### Performance

- Fibre type: .....POF
- Wave length:.....650 nm
- Optical insertion loss (typ.): .....2 dB max.
- Jacketed external diameter:.....2.2mm
- Temperature range:.....-25°C to +70°C
- Cable retention:.....49N
- Mating cycles without cleaning:.....50
- Max. mating cycles:.....500

#### Construction

- Contact body: Copper alloy

#### Connector accommodation

Any TRIM TRIO® size 16 contact can be used in any contact position in any connector in the TRIM TRIO® size 16 interconnection system : UTP, UTS, UTG, UTO.



### Fibre optic contacts

Ordering information	
<b>POF Contacts (Plastic Optical Fibre)</b>	
Male contact.....RMPOF1000	Female contact.....RCPOF1000B

POF Contact (Plastic Optical Fibre)																																					
<p><b>STANDARD TOOLING KIT - P/N 80MS0004</b>                      The <i>standard tooling kit</i> is made of the part numbers below that can be ordered separately as well.</p> <table border="1"> <thead> <tr> <th>Part numbers</th> <th>Descriptions</th> </tr> </thead> <tbody> <tr> <td>80WD0005</td> <td>Stripping tool</td> </tr> <tr> <td>80WD0025</td> <td>Automatic stripping tool for Ø 0.5 mm, 0.6 mm, 0.7 mm &amp; 3.8 mm</td> </tr> <tr> <td>80WM0006</td> <td>Ruler</td> </tr> <tr> <td>80WP0005</td> <td>Polishing plate</td> </tr> <tr> <td>80WP0013</td> <td>Non slip base (to hold the polishing plate)</td> </tr> <tr> <td>80WP0014</td> <td>Polishing disk (grain size 9µm)</td> </tr> <tr> <td>80WP0018</td> <td>Polishing tool</td> </tr> <tr> <td>80WP0019</td> <td>Polishing disk (grain size 30µm)</td> </tr> <tr> <td>80WS0002</td> <td>Crimping plier</td> </tr> </tbody> </table>	Part numbers	Descriptions	80WD0005	Stripping tool	80WD0025	Automatic stripping tool for Ø 0.5 mm, 0.6 mm, 0.7 mm & 3.8 mm	80WM0006	Ruler	80WP0005	Polishing plate	80WP0013	Non slip base (to hold the polishing plate)	80WP0014	Polishing disk (grain size 9µm)	80WP0018	Polishing tool	80WP0019	Polishing disk (grain size 30µm)	80WS0002	Crimping plier	<p><b>SPECIFIC TOOLING LIST - can be ordered only separately</b></p> <table border="1"> <thead> <tr> <th>Part numbers</th> <th>Descriptions</th> </tr> </thead> <tbody> <tr> <td>80WG0010</td> <td>Needle</td> </tr> <tr> <td>80WG0015</td> <td>Capsule</td> </tr> <tr> <td>80WG0016</td> <td>Syringe</td> </tr> <tr> <td>80WN0005</td> <td>Dry air spray</td> </tr> <tr> <td>80WN0006</td> <td>Optical paper</td> </tr> <tr> <td>80WN0012</td> <td>Dropping bottle</td> </tr> <tr> <td>80WN0008</td> <td>Wiping solvent</td> </tr> </tbody> </table>	Part numbers	Descriptions	80WG0010	Needle	80WG0015	Capsule	80WG0016	Syringe	80WN0005	Dry air spray	80WN0006	Optical paper	80WN0012	Dropping bottle	80WN0008	Wiping solvent
Part numbers	Descriptions																																				
80WD0005	Stripping tool																																				
80WD0025	Automatic stripping tool for Ø 0.5 mm, 0.6 mm, 0.7 mm & 3.8 mm																																				
80WM0006	Ruler																																				
80WP0005	Polishing plate																																				
80WP0013	Non slip base (to hold the polishing plate)																																				
80WP0014	Polishing disk (grain size 9µm)																																				
80WP0018	Polishing tool																																				
80WP0019	Polishing disk (grain size 30µm)																																				
80WS0002	Crimping plier																																				
Part numbers	Descriptions																																				
80WG0010	Needle																																				
80WG0015	Capsule																																				
80WG0016	Syringe																																				
80WN0005	Dry air spray																																				
80WN0006	Optical paper																																				
80WN0012	Dropping bottle																																				
80WN0008	Wiping solvent																																				

# UTS Series

## Contacts







UTS Series

# Technical information

- Tooling ..... 154
- Assembly intruction ..... 156
- Dimensions overmoulded harnesses ..... 162
- Extraction tools ..... 162
- Rated current & working voltage ..... 163
- UV resistance ..... 164
- UL94 + UL1977 ..... 165
- IEC 61984 & IP codes explained ..... 168
- What is NEMA rating ? ..... 170
- Ethernet for the layman ..... 171

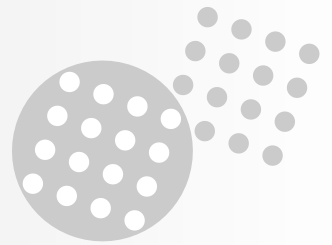

## Tooling

### Automatic crimping tools



**Mecal is leader in manufacturing tooling for crimping terminals over a stripped wire.**

Established in 1976, Mecal has become one of the world's leading companies dedicated to the design and manufacture of semi automatic production tools for strip fed, open barrel crimp terminals, serving the Automotive, Telecom and Datacomm industry.



**The extreme environment interconnect specialist "from deep sea to deep space".**

Souriau designs manufactures and markets high performance interconnect solutions for severe environments dedicated to the aerospace, defence, light and heavy industry markets.

**Souriau has been working in partnership with Mecal for a good number of years. With sales offices located in all major industrial regions of the world, the combined strengths of both organisations has resulted in a truly global solution to all your production tooling needs.**



Mini Applicator



Stripper



Presses

Mecal sales network:

[www.mecal.net/eng/retevendita.php](http://www.mecal.net/eng/retevendita.php)



### Crimptooling table

#### Standard contacts

Contact size	Part number	Head	Handles
#20 1mm	RM/RC 24W3 -	S20RCM	SHANGLES
	RM/RC 20W3 -		
	RM/RC 18W3 -		
	SM 24W3S-(1) SC 24W3S-(1)	S20SCM20	
	SM 24WL3S-(2) SC 24WL3S-(2)		
	SM/SC 20W3S-(1) SM/SC 20WL3S-(2)		
#16 1.6mm	RM/RC 28M1 -	S16RCM20	
	RM/RC 24M9 -		
	RM/RC 20M13 -		
	RM/RC 20M12 -		
	RM/RC 16M23 -	S16RCM16	
	RM/RC 14M50 -	S16RCM1450	
	RM/RC 14M30 -	S16RCM14	
	SM/SC 24M1 - SM/SC 24ML1 -	S16SCM20	
	SM/SC 20M1 - SM/SC 20ML1 -		
	SM/SC 16M1 - SM/SC 16ML1 -	S16SCML1	
	SM/SC 14M1 - SM/SC 14ML1 -		
	SM/SC 16M11 - SM/SC 16ML11 -	S16SCML11	



(1) contact reeled (2) loose contact  
Note: endurance of SHANGLES tool = 5 000 cycles.

Contact size	Part number	Tool with separate locator			Extraction tools
		Hand tool	Positioner + locator setting		
#12 2.4mm	8291 1457N- / 8291 1456-	M317	VGE10077A	1-2	5106020924
	8291 1459N- / 8291 1458-			2	
	8291 1461N- / 8291 1460-			2	
	8291 1463N- / 8291 1462-			3	
	8291 1465N- / 8291 1464-			3	
	8291 1467N- / 8291 1466-			4	
#8 3.6mm	8291 3601A / 8291 3600A	M317	VGE10078A	3	51060210936
	8291 3603A / 8291 3602A			3	
	8291 3605A / 8291 3604A			4	
	8291 3607A / 8291 3606A			5	
	8291 3609A / 8291 3608A			6/7	

#### Specific contacts



Contact size	Part number	Hand tools (SHANGLES) head	Tool with separate locator			Extraction tools			
			Hand tool	Positioner + locator setting					
#16 Ø 1.6mm Longer RM contact	RM28M1GE1 - RM24M9GE1 - RM20M13GE1 -	S16RCM20	M317	UH25	3				
	RM16M23 GE1 -					MH860	MH86186	6/8	
	RM14M50 GE1 -					S16RCM1450			
	RM14M30 GE1 -	S16RCM14							
	#16 Ø 1.6mm Shorter RC contact	RC28M1GE7 - RC24M9GE7 -				S16RCM20	MH860	MH86164G	3
		RC20M13GE7 - RC20M12GE7 -							
RC16M23GE7 -		5/6							
RC14M50GE7 -		S16RCM16	5/7						
RC14M30GE7 -		S16RCM14	6/8						

#### Coaxial contacts

See cabling notice chapter Appendices, pages 178 to 182.

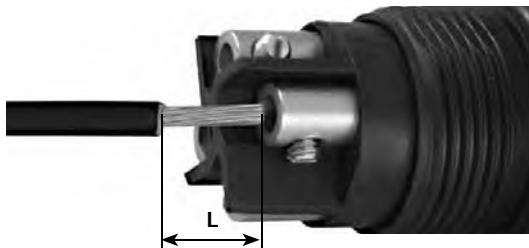

### Assembly instruction

Wire stripping crimp version			
	Part number		Stripping length L (mm)
	Male	Female	
<b>Machined contact</b>	<b>#16</b>		
	RM28M1- / RM24M9- RM20M13- / RM20M12-	RC28M1- / RC24M9- RC20M13- / RC20M12-	4.8
	RM16M23- / RM14M50- RM14M30-	RC16M23- / RC14M50- RC14M30-	7.1
	<b>#20</b>		
	RM24W3- / RM20W3- RM18W3-	RC24W3- / RC20W3- RC18W3-	4.8
<b>Stamped &amp; formed</b>	<b>#16</b>		
<b>Without insulation support</b>			
	SM24M1- / SM24ML1- SM20M1- / SM20ML1	SC24M1- / SC24ML1- SC20M1- / SC20ML1-	4
	SM16M11- / SM16ML11-	SC16M11- / SC16ML11-	4.65
<b>With insulation support</b>			
	SM16M1- / SM16ML1-	SC16M1- / SC16ML1-	6.35
	SM14M1- / SM14ML1-	SC16M11- / SC16ML11-	6.35
<b>Screw contacts</b>	<b>Power contacts #12</b>		
	8291 1457- / 8291 1459- / 8291 1461- / 8291 1463- / 8291 1465- / 8291 1467-	8291 1456- / 8291 1458- / 8291 1460- / 8291 1462- / 8291 1464- / 8291 1466 -	7 to 8
	<b>Power contacts #8</b>		
	8291 3601- / 8291 3603- / 8291 3605- 8291 3607- / 8291 3609-	8291 3600- / 8291 3602- / 8291 3604- / 8291 3606- / 8291 3608-	6.5 to 7.5
	<b>Contact delivered with connector</b>		5.8

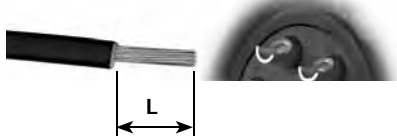
Wire stripping solder version			
	Part number		Stripping length L (mm)
	Male	Female	
<b>Machined contact</b>	<b>#16 &amp; #20</b>		5
			

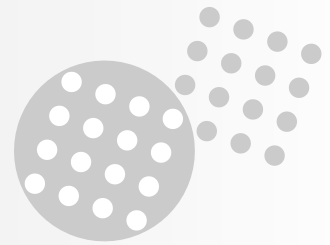

### Crimping

One of the key factors which affects the performance of a connector, is the way contacts are terminated. Crimped connections are nowadays seen as the best solution to ensure quality throughout the lifetime of the product. Here are some reasons why we recommend this method of termination for UTS connectors:

#### Advantages (Extract from the IEC 60352-2):

- Efficient processing of connections at each production level
- Processing by fully-automatic or semi-automatic crimping machines, or with hand operated tools
- No cold-soldered joints
- No degradation of the spring characteristic of female contacts by the soldering temperature

- No health risk from heavy metal and flux steam
- Preservation of conductor flexibility behind the crimped connection
- No burnt, discolored and overheated wire insulation
- Good connections with reproducible electrical and mechanical performances
- Easy production control.

To ensure that the crimp tooling is performing according to original specifications, it is important to carry out regular checks. A common way to check the performance of tooling is with a simple pull test, ideally using a dedicated electric pull tester. Minimum recommended full forces are indicated in the tables below:

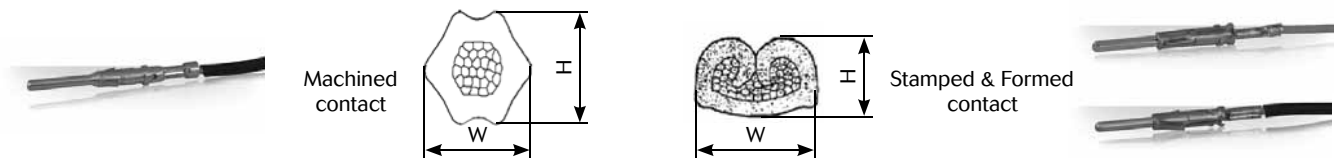

Active contact part	Contact type	Die location on heads	Wire section range	Section (mm <sup>2</sup> )	Tensile straight test (mini)	Height (Mm) H (±0.075)	Width (Mm) W (±0.075)	Head's P/N
Machined contacts size 20	RM/RC 24W3*	26/24	AWG 26	0.12 min	15 N	0.95	1.27	S20RCM
			AWG 24	0.25 max	32 N			
	RM/RC 20W3*	22/20	AWG 22	0.32 min	40 N	1.26	1.78	
AWG 20			0.50 max	60 N				
RM/RC 18W3*	20/18	AWG 20	0.50 max	60 N	1.35	1.86		
		AWG 18	0.82 max	90 N				
S & F contacts size 20	SM/SC 24WL3TK6*	26/24	AWG 26	0.12 min	15 N	0.80	1.49	S20SCM20
			AWG 24	0.25 max	32 N			
	SM/SC 20WL3TK6*	22/20	AWG 22	0.32 min	40 N	1.01	1.53	
AWG 20			0.50 max	60 N				
Machined contacts size 16	RM/RC 28M1K*	30/28	AWG 30	0.05 min	11 N	1.14	1.41	S16RCM20
			AWG 28	0.08 max	11 N			
	RM/RC 24M9K*	26/24	AWG 26	0.12 min	15 N	1.15	1.41	
			AWG 24	0.25 max	32 N			
	RM/RC 20M13K*	22/20	AWG 22	0.32 min	40 N	1.26	1.76	
			AWG 20	0.50 max	60 N			
			AWG 22	0.32 min	40 N			
	RM/RC 20M12K*	20	AWG 20	0.50 max	60 N	1.66	2.18	
			18	AWG 18	0.82 max			90 N
	RM/RC 16M23K*	16	AWG 16	1.50 max	150 N	1.96	2.43	S16RCM16
16			AWG 16	1.50 min	150 N	2.10	2.68	
RM/RC 14M30K*	14	AWG 14	2.50 min	230 N	2.30	2.78	S16RCM14	
		16	AWG 16	1.50 min	150 N	2.09		2.59
RM/RC 14M50K*	14	AWG 14	2.50 max	230 N	2.26	2.71	S16RCM1450	
		16	AWG 16	1.50 max	150 N	1.79		2.58
S & F contacts size 16	SM/SC 24ML1TK6*	26/24	AWG 26	0.12 min	15 N	0.84	1.50	S16SCM20
			AWG 24	0.25 max	32 N			
	SM/SC 20ML1TK6*	22/20	AWG 22	0.32 min	40 N	1.02	1.54	
			AWG 20	0.50 max	60 N			
	SM/SC 16ML11TK6*	18	AWG 18	0.82 min	90 N	1.32	2.09	S16SCML11
			AWG 16	1.50 max	150 N	1.36	2.10	
SM/SC 16ML1TK6*	16	AWG 16	1.50 min	150 N	1.49	2.02	S16SCML1	
		AWG 16	1.50 max	150 N	1.7	2.05		
SM/SC14ML1TK6*	14	AWG 14	2.50 max	230 N	1.79	2.58		

(1): example of plating, for other plating see page 143



### UTS 0 assembly (mounting suggestion)

- Strip wires, crimp or solder contacts
- Insert contacts into connector cavities (insert manually or use tool RTM205 crimp contacts only)
- Place receptacle in the panel cut-out, with optional gasket
- Secure receptacle with screws (not supplied)

**Front mounting : Crimp version**

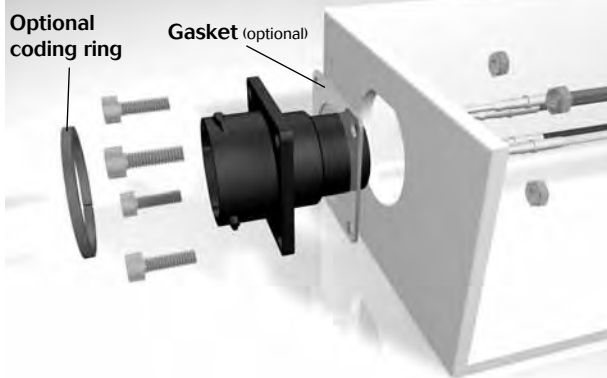

**Rear mounting : Crimp version**

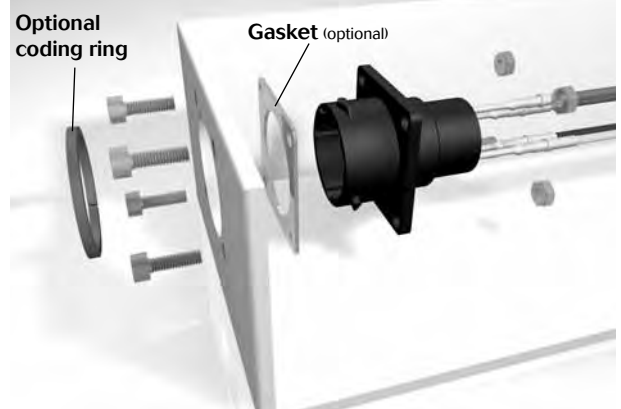

**Front mounting : Solder version**

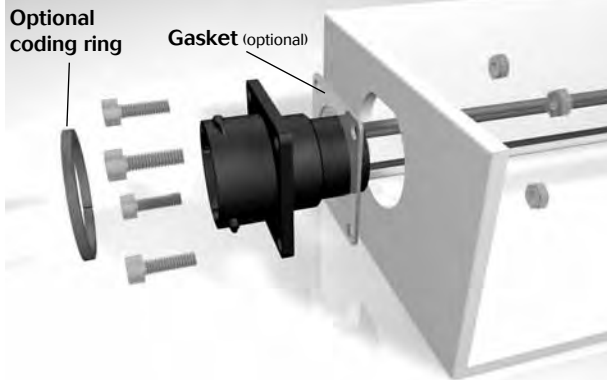

**Rear mounting : Solder version**

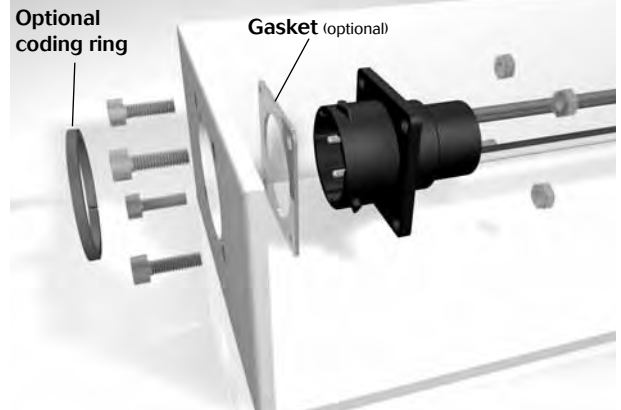

3mm max → ← Receptacle flange

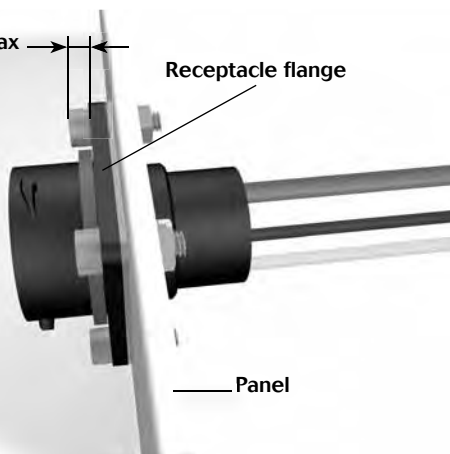

3mm max → ← Receptacle flange

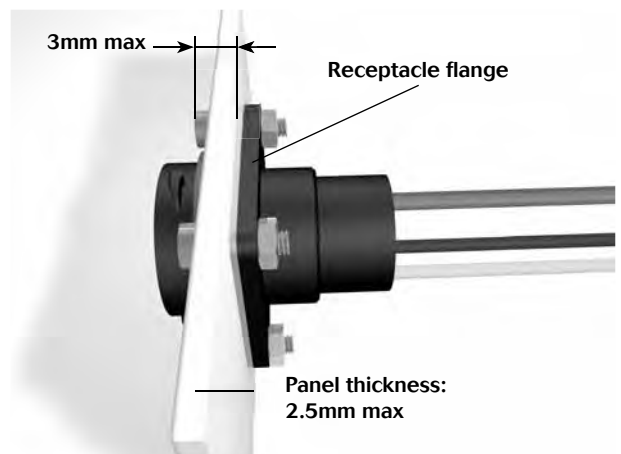

# UTS Series

## Technical information



### UTS 7 assembly (mounting suggestion)

- Strip wires, crimp or solder contacts
- Insert contacts into connector cavities (insert manually or use tool RTM205 crimp contacts only)
- Seat o-ring, place receptacle in the panel cut-out
- Tighten jam nut

Shell size	Jam nut torque (Nm)	Tool tightening	Ø Wire	
			Standard version	Discrete wire sealing
8	1.5	19.05	3.2 mm max.	from 1.7 mm to 3.0 mm
10	3	22.25		
12	4	27.15		
14	5	30.19		
18	5	36.5		

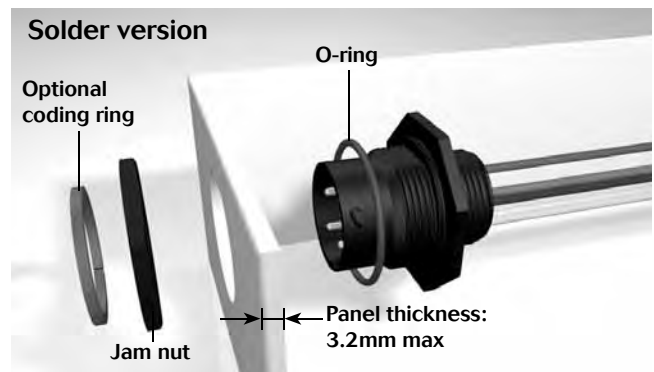
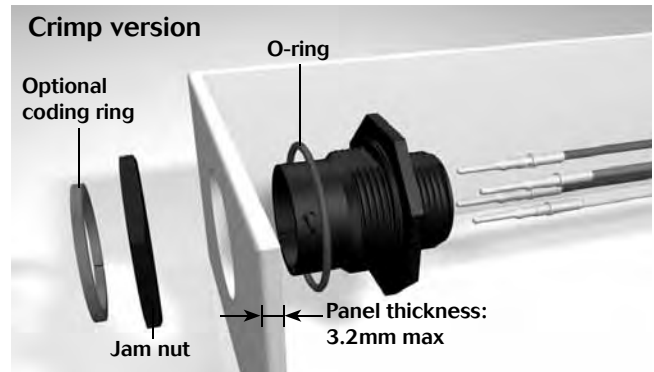
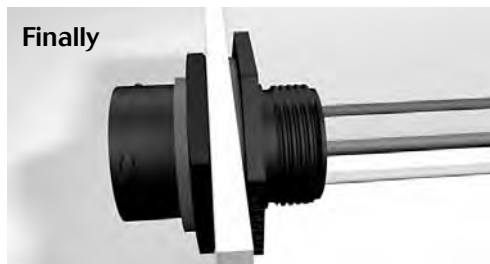

### UTS 6 GN / UTS 7 GN assembly

- Slide accessories on the cable (make sure to keep compression ring on the grommet)
- Strip wires and crimp contacts
- Insert first contact into the grommet (first contact in cavity A, use male contact to pierce the grommet, no tool is required), then insert the contact in the connector cavity A (insert manually or use tool RTM205)
- Place the grommet and compression ring on the insulator
- Insert the other contacts
- Tighten nut (recommended torque: see note)

Shell size	Nut tightening torque (Nm)	Ø Wire
10	1	from 1.7 mm to 3.0 mm
12	1.5	
14	1.5	

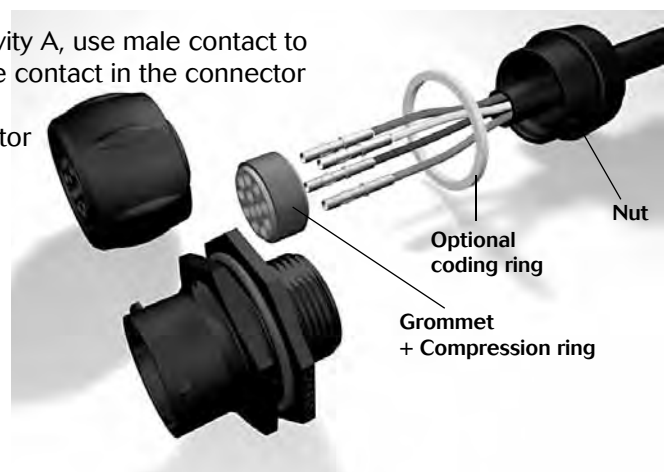





### Assembly instruction

#### UTS 1 JC / UTS 6 JC assembly: Crimp version

- Slide accessories on the cable

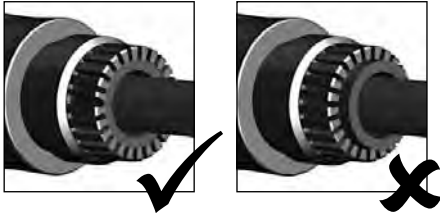

Make sure the seal is positioned as shown.

- Strip external cable jacket
- Strip wires and crimp contacts
- Insert contacts into connector cavities (insert manually or use tool RTM205)
- Tight adapter with plug, choose right seal (waste the other seal), tight nut with adapter (recommended torque values to be applied according to the table - right)
- Caution: only one of both delivered gasket should be used !

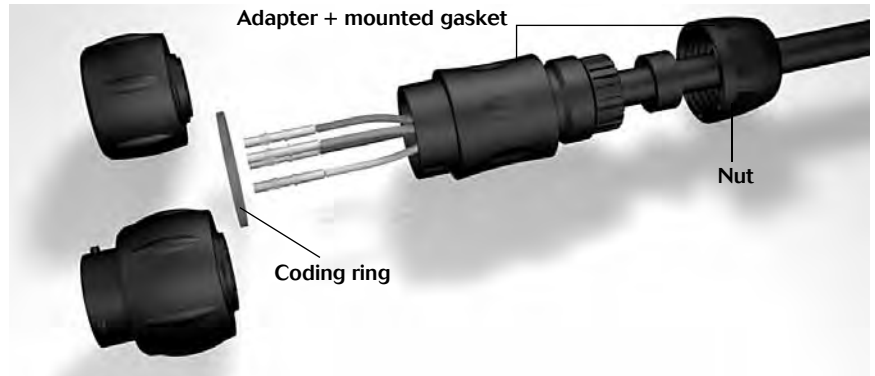

Shell size	Recommended jacket strip length (mm)		Adapter tightening torque (Nm)	Nut tightening torque (Nm)	Ø Cable range Standard seal	Ø Cable range Reducing seal	Ø Wire
	Male	Female					
10	21	29	1.5	2	2.5/8.0	1.5/5.0	3.2 mm max.
12	25	33	2	2.5	5.0/12.0	3.0/9.0	
14	29	36	3	2.5	7.0/14.0	5.0/12.0	
18	37	45	4	3.5	9.0/18.0	7.0/16.0	

#### UTS 6 JC assembly: Solder version

- Slide accessories on the cable

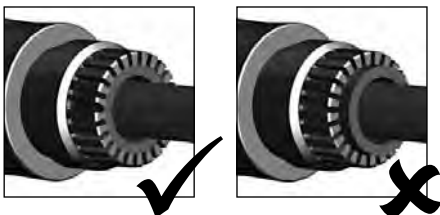

Make sure the seal is positioned as shown.

- Strip external cable jacket
- Strip wires and solder contacts
- Tight adapter with plug, choose right seal (waste the other seal), tight nut with adapter (recommended torque values to be applied according to the table - right)
- Caution: only one of both delivered gasket should be used !

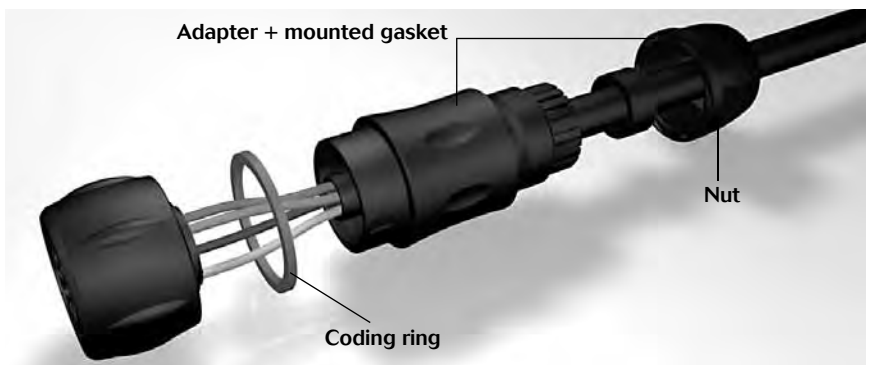

Shell size	Recommended jacket strip length (mm)		Adapter tightening torque (Nm)	Nut tightening torque (Nm)	Ø Cable range Standard seal	Ø Cable range Reducing seal	Ø Wire
	Male						
8	17		1	0.75	2.5/6.5	1.5/5.0	3.2 mm max.
10	21		1.5	2	2.5/8.0	1.5/5.0	
12	25		2	2.5	5.0/12.0	3.0/9.0	
14	29		3	2.5	7.0/14.0	5.0/12.0	

# UTS Series

## Technical information



### UTS 1 GJC / UTS 6 GJC assembly

- Slide accessories on the cable (make sure to keep compression ring on the grommet)
- Strip external cable jacket
- Strip wires and crimp contacts
- Insert first contact into the grommet (first contact in cavity A, the contact pierces the grommet, no tool is required), then insert the contact in the connector cavity A (insert manually or use tool RTM205)
- Place the grommet and compression ring on the insulator
- Insert the other contacts
- Tight adapter with plug, choose right seal (waste the other seal), tight nut with adapter (recommended torque values to be applied according to the table - right).

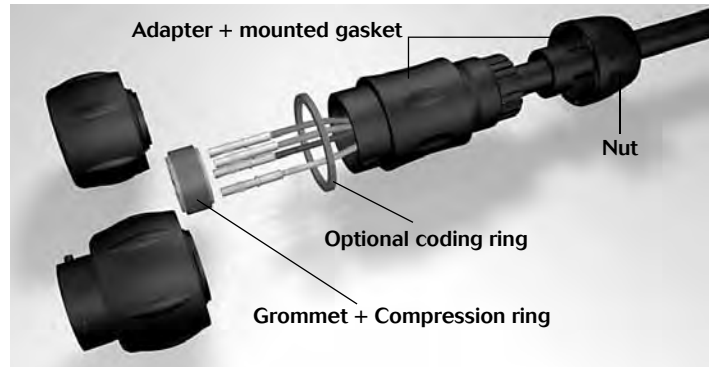

Shell size	Recommended jacket strip length (mm)		Adapter tightening torque (Nm)	Nut tightening torque (Nm)	Ø Cable range Standard seal	Ø Cable range Reducing seal	Ø Wire
	Male	Female					
10	21	29	1.5	2	2.5/8.0	1.5/5.0	from 1.7 mm to 3.0 mm
12	25	33	2	2.5	5.0/12.0	3.0/9.0	
14	29	36	3	2.5	7.0/14.0	5.0/12.0	

### Mated connector length

UTS0 + UTS6

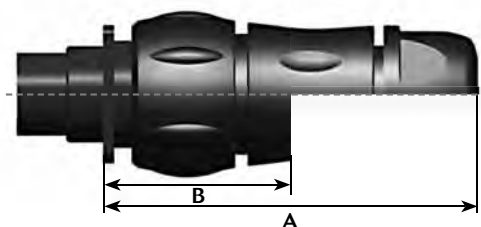

UTS7 + UTS6

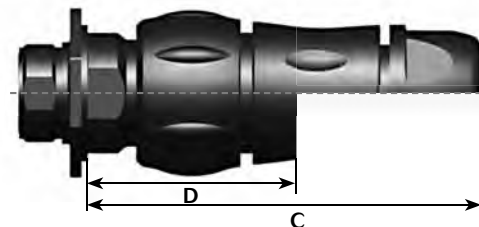

Shell size	UTS0 + UTS6 EN JC & CJC	UTS0 + UTS6 EN GN	UTS7 + UTS6 EN JC & CJC	UTS7 + UTS6 EN GN
	A max	B max	C max	D max
8	61.1	-	66.6	-
10	73.2	39.6	77.3	43.7
12	77.6	39.4	81.7	43.5
14	83.5	40	87.6	44.1
18	93.1	-	97.2	-

Note: all dimensions are in mm



### Dimensions overmoulded harnesses

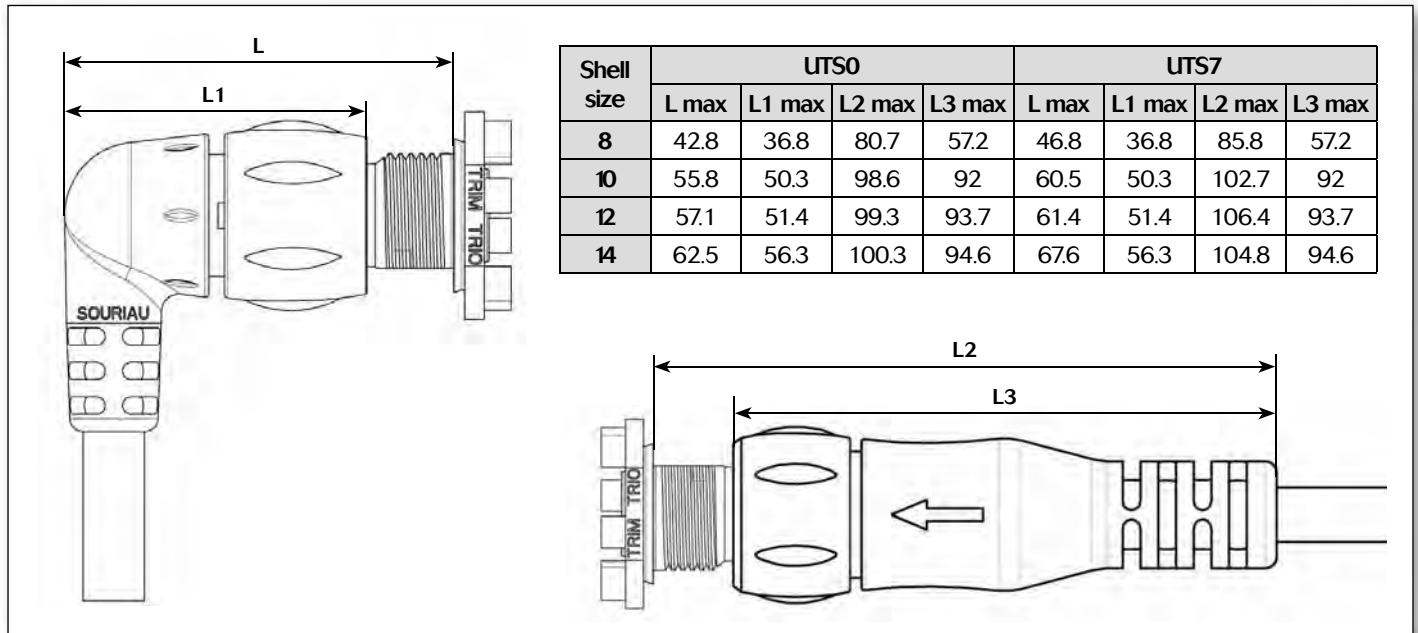

### Extraction tools

Contact size	Extractor
#20	RX20D44
#16	RX2025GE1
#12	51060210924
#8	51060210936



#### Extraction tools instruction for size 16

Special case with the tool RX2025GE1:

A - When setting up in the cell, keep firmly the tool by the hexagonal metallic part and insert tool in cavity.

B - Push the tool by the handle to extract the contact.



Extraction:

Place the tool into the cavity from front face of the connector, push on the handle, then remove the contact..



### Rated current & working voltage

#### Current carrying capacity

The current carrying capacity of a connector is limited by the thermal properties of materials used in its construction. The amount of current that can be handled depends on the size of cable used, the ambient temperature and the heat that is generated inside the connector. Part 3 of the IEC 60512 standard determines through a derating curve, the maximum current permissible, which varies from one layout to another (Fig.1 & Fig.2). Wire size plays an important role as well, since they help to dissipate heat and avoid overheating (Fig.1 & Fig.3).

Please note that the curve should be adjusted when dealing with potential hot spots, which can occur as a result of unequal loading of current across a number of contacts. As a general rule, it is best to avoid locating power handling contacts in the middle of the connector; try to locate them towards the edge where heat can be dissipated more effectively. Eventually you should find a level which represents the permissible operating range:

**Fig.1: UTS 12-4 – 1.5mm<sup>2</sup> wires**

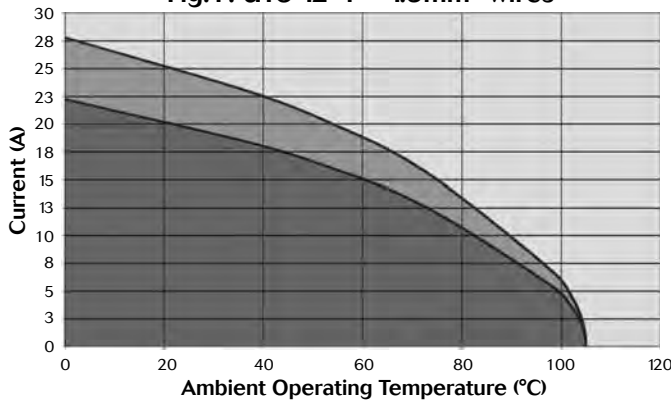

**Fig.2: UTS 12-8 – 1.5mm<sup>2</sup> wires**

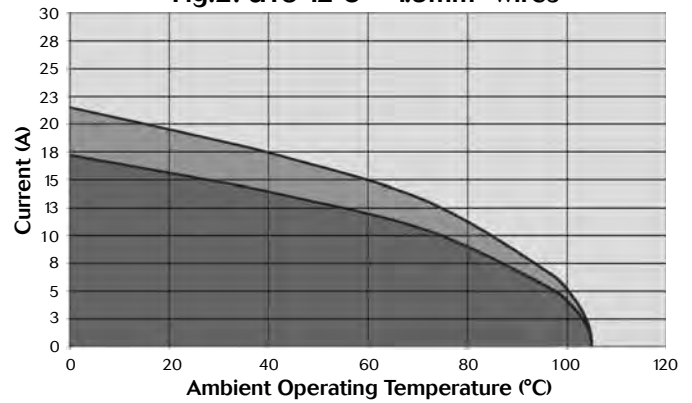

**Fig.3: UTS 12-4 – 2.5mm<sup>2</sup> wires**

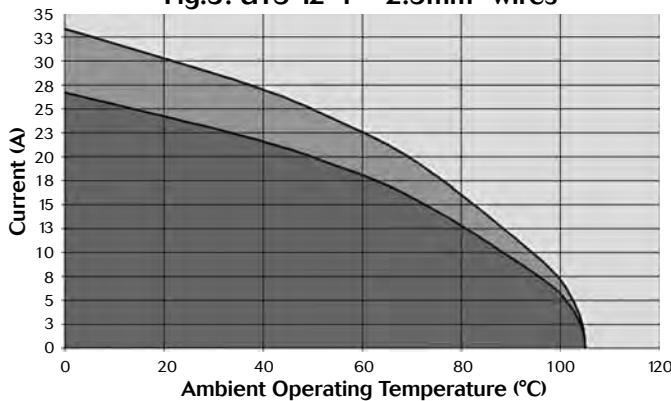

- Current use
- Limited use
- Not recommended use

The **rated current** is defined as uninterrupted continuous current that a connector can take when all contacts are energized simultaneously without exceeding the maximum limit of temperature. The earth contact is never loaded.



### UV resistance

Solar radiation affects all materials, but plastics can be susceptible to extreme degradation over time. The choice of materials for the UTS series was therefore a critical consideration.

All over the world we are not exposed to the same amount of energy given by the sun. The chart shown here clearly illustrates this.

So we performed test according to the ISO 4892-2 and simulated 5 years exposure to outdoor environments (temperature, humidity, etc...)

After this period there was no significant colour variation, no crazing, no cracking and no major variation of mechanical properties.

Yearly mean of daily irradiation in UV (280-400 nm) on horizontal plane (J/cm<sup>2</sup>) (1990-2004)

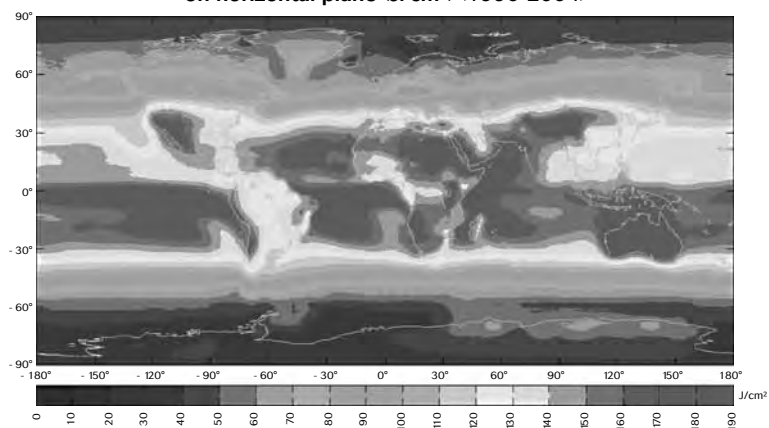



### There are two main standards for industrial connectors: UL94 & UL1977

## UL94

This standard is dedicated to plastics flammability. It characterises how the material burns in various orientation and thicknesses.

The UTS series has been rated at **V-0 & HB**.

Procedure: A specimen is supported in a vertical or horizontal position and a flame is applied to the bottom of the specimen. The flame is applied for ten seconds and then removed until flaming stops, at which time the flame is reapplied for another ten seconds and then removed. Two sets of five specimens are tested. The two sets are conditioned under different conditions.

#### V-0 Vertical burning:

- Specimens must not burn with flaming combustion for more than 10 seconds after either test flame application.
- Total flaming combustion time must not exceed 50 seconds for each set of 5 specimens.
- Specimens must not burn with flaming or glowing combustion up to the specimen holding clamp.
- Specimens must not drip flaming particles that ignite the cotton.
- No specimen can have glowing combustion remain for longer than 30 seconds after removal of the test flame.

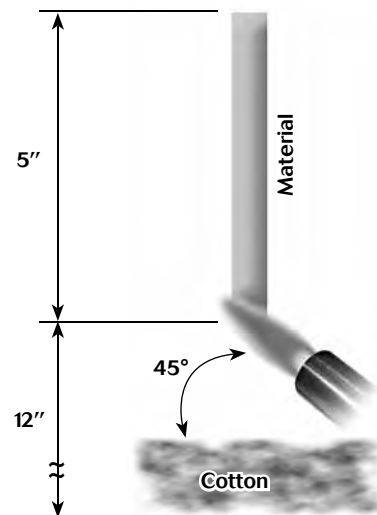

#### HB Horizontal burning:

- A material classed HB shall not have a burning rate exceeding 40 mm per minute over a 75 mm span for specimens having a thickness of 3.0 to 13 mm.
- A material classed HB shall not have a burning rate exceeding 75 mm per minute over a 75 mm span for specimens having a thickness less than 3.0 mm.
- A material classed HB shall cease to burn before the 100 mm reference mark.

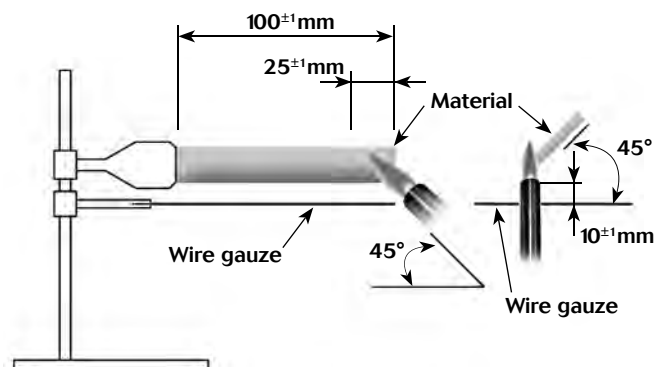



### UL 1977

There are several standards which deal with plug and receptacle. Each of them is only for a small area of applications. It could be telecommunication, Etc. The UL 1977 covers single and multipole connectors intended for factory assembly.

Requirements apply to devices in taking into account intensity and voltage. There are categories as follows:

	0	30 V (42 V peak)	600 V
0	Type 0	Type 1A	
8.3 A			
31 A	Type 1B	Type 2	
200 A		Type 3	
1000 A	Type 4		

According to above table, the level of performance that has to be reached could be different. Most of them are explained in the following page.

### Insulating materials:

Material uses for electrical insulation, as a minimum, have to comply with the characteristics shown below:

• **Minimum ratings for polymeric materials**

Type	Flame rating	Relative thermal index (RTI) Electrical/mechanical w/o impact **/**
0	-	50/50
1A	HB	50/50
1B	HB	50/50
2	HB	50/50
3	HB	50/50
4	HB	50/50

\* The RTI of the material shall not be lower than the temperature measured during the Temperature Test.  
 \*\* For a thickness less than that for which a value has been established, the RTI of the minimum thickness with an established value shall be used.

### Assembly:

Connector has to be keyed to prevent any mismatching that can damage the machine or hurt the user. In the same way, plugs and sockets have to be equipped to protect persons against contact with live parts.

Finally the identified grounding contact shall be located so that the corresponding electrical continuity has to be completed before any other contact.



## UL1977

### Spacing:

For a 250V max connector, distance through air or over material shall be 1.2mm whereas from 250V to 600V connector the spacing is 3.2 minimum. These distances have to be taken between uninsulated live parts as shown in the matrix below:

• **Applicability of spacing requirements**

Type	Uninsulated live part - uninsulated live part of opposite polarity	Uninsulated live part - uninsulated grounded metal part	Uninsulated live part - exposed dead metal part
0	No	No	No
1A	Yes	Yes	Yes
1B	Yes	Yes	No
2	Yes	Yes	Yes
3	Yes	Yes	Yes
4	Yes	Yes	Yes

An alternative way to determine voltage rating is with the Dielectric-Withstand test. If during one minute there is no arc-over or breakdown the rated voltage is given as given below:

- a) 500 volts for a type 1B device
- b) 1000 volts plus twice rated voltage for types 1A, 2, 3 and 4 devices.

### Marking:

A device shall be legibly marked with the manufacturer's trade name, trade mark, or other descriptive marking by which the organisation responsible for the product may be identified. (Exception: If the device is too small, or where the legibility would be difficult to attain, the manufacturer's name, trademark, or other descriptive marking may appear on the smallest unit container or carton)

The following shall be marked on the device or on the smallest unit container or carton or on a stuffer sheet in the smallest unit container or carton:

- a) The catalogue number or an equivalent designation
- b) The electrical rating in both volts and amperes, if assigned
- c) Whether ac or dc, if restricted
- d) Flammability class, if identified

Example - Marking for the arrangement 10-3: **10A 500V UL94 V-0**





### IEC 61984

The norm is dedicated to connectors with rated voltage above 50V and up to 1000V and rated currents up to 125A per contact. But depending of your application connectors should be compliant with another standard. This has to be double checked with the customer.

There are lot of constructional requirements and performances specified in that standard. Most of them are illustrated in greater details hereafter.

#### Provisions for earthing:

The UTS connector is intended to be used on Class II systems. Even if the purpose of our connector is not to interrupt current, we often see a need to add a protective earth contact. Then this one shall be a "First mate, last break" style. Critically, among all of the normal assumptions we make in designing a connector, this contact has to be considered as a live part and must be protected against electric shock by double or reinforced insulation.

#### IP Code:

IP is a coding system defined by the IEC 60529 to indicate the degrees of protection provided by an enclosure. The aim of this is to give information regarding the accessibility of live parts against ingress of water and other foreign bodies.

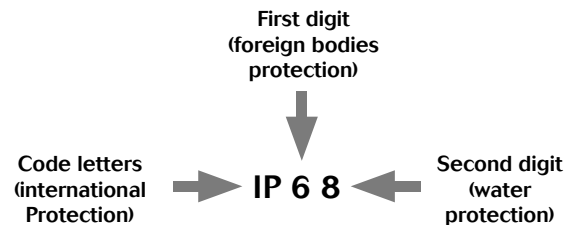

1 <sup>st</sup> digit	Degree of protection	2 <sup>nd</sup> digit	Degree of protection
0	No protection against accidental contact. No protection against solid foreign bodies.	0	No protection against water.
1	Protection against contacts with any large area by hand and against large solid foreign bodies with a diameter bigger than 50 mm.	1	Drip-proof. Protection against vertical water drips.
2	Protection against contacts with the fingers. Protection against solid foreign bodies with a diameter bigger than 12 mm.	2	Drip-proof. Protection against water drips up to a 15° angle.
3	Protection against tools, wires or similar objects with a diameter bigger than 2.5 mm. Protection against small solid bodies with a diameter bigger than 2.5 mm.	3	Spray-proof. Protection against diagonal water drips up to a 60° angle.
4	As 3 however diameter is bigger than 1 mm.	4	Splash-proof. Protection against splashed water from all directions.
5	Full protection against contacts. Protection against interior injurious dust deposits.	5	Hose-proof. Protection against water (out of a nozzle) from all directions.
6	Total protection against contacts. Protection against penetration of dust.	6	Protection against temporary flooding.
		7	Protection against temporary immersions.
		8	Protection against water pressure. Pressure to be specified by supplier.

UTS offers high sealing performance IP68 / 69K...  
Even in dynamic situations.

In addition to the IEC 60529 we conjointly use the DIN 40050 part 9 which are dedicated to road vehicles. The main differences are:

- **First digit:** 5 replaced by 5K, 6 by 6K. In the DIN the tested equipment is not depressurized as it is in the IEC.
- **Second digit:** 5K and 6K has been added and are equivalent respectively to 5 and 6 but with higher pressure. 9K which represents the High pressure cleaning.

9K	High pressure hose-proof. Protection against high pressure water (out of a nozzle) from all directions.
----	--

IEC 61984 ed.2.0 "Copyright © 2008 IEC Geneva, Switzerland.www.iec.ch"  
IEC 60664-1 ed.2.0 "Copyright © 2007 IEC Geneva, Switzerland.www.iec.ch"



### IEC 61984

#### Overvoltage

UTS connectors are qualified to be used on systems rated at Overvoltage category III

Per the IEC 60664-1 (formerly VDE 0110) each category is linked to the end application and where the device will be implemented:

- **Category IV** (primary overcurrent protection equipment):  
Origin of the installation
- **Category III** (Any fixed installation with a permanent connection)  
Fixed installation and equipment and for cases where the reliability and the availability is subject to special requirements
- **Category II** (Domestic appliances):  
Energy consuming equipment to be supplied from the fixed installation
- **Category I** (Protected electronic circuit):  
For connection to circuit in which measures are taken to limit transient overvoltage.

#### Pollution degree

Per the IEC 60664-1 (formerly VDE 0110) the environment affects the performance of the insulation. Particles can build a bridge between two metal parts. As a rule dust mixed with water can be conductive and more generally speaking metal dust is conductive. Finally, the standard defines 4 levels of pollution:

- **Degree 1** (Air conditioned dry room):  
No pollution or only dry, non conductive pollution occurs. The pollution has no influence.
- **Degree 2** (Personal computer in a residential area):  
Only non conductive pollution occurs except that occasionally a temporary conductivity caused by condensation is to be expected.
- **Degree 3** (Machine tools):  
Conductive pollution occurs or dry non-conductive pollution occurs which becomes conductive due to condensation which is to be expected.
- **Degree 4** (Equipments on roof, locomotives):  
Continuous conductivity occurs due to conductive dust, rain or other wet conditions.

Finally, the harsher the environment is, the longer clearance and creepage distances should be. Nonetheless, according the IEC 61984, enclosure rated at IP54 or higher can be dimensioned for a lower pollution degree. This applies to mated connectors disengaged for test and maintenance.

#### Marking

The marking should give enough details to the user to know what the main characteristics are and without going deep in technical documentation. Below examples identify the suitability of the connector:

- **Example 1:**  
Marking of a connector with rated current 16A, rated voltage 400V, rated impulse voltage 6kV and pollution degree 3, 2 and 1 for use in any system, preferably unearthed or delta-earthed systems:

16A 400V 6kV 3

- **Example 2:**  
Marking of a connector with rated current 16A, rated insulation voltages line-to-earth 250V, line-to-line 400V, rated impulse voltage 4kV and pollution degree 3, 2 and 1 for use in earthed systems:

16A 250V 400V 4kV 3



### What is NEMA rating ?

- NEMA ratings vs IP ratings

Whereas IP ratings only consider protection against ingress of foreign bodies - first digit - and ingress of water (second digit), NEMA ratings consider these but also verify protection from external ice, corrosive materials, oil immersion, etc.

The correlation between NEMA & IP being limited only to dust and water, we can state that a NEMA type is *equivalent to* an IP rating but it is not possible to say the contrary.

Below a list of some NEMA standards:

Enclosure rating	IP20	IP22	IP55	IP64	IP65	IP66	IP67
Type 1	•						
Type 3				•			
Type 3R		•					
Type 3S				•			
Type 4						•	
Type 4X						•	
Type 6							•
Type 12			•				
Type 13					•		

• indicates compliance



Type 6 rating can be either Type 6 or Type 6P - please see below:

6	IP67	Enclosures constructed for either indoor or outdoor use to provide a degree of protection to personnel against incidental contact with the enclosed equipment, falling dirt, hose-directed water, the entry of water during occasional temporary submersion at a limited depth and damage from external ice formation.
6P	IP67	Enclosures constructed for either indoor or outdoor use to provide a degree of protection to personnel against incidental contact with the enclosed equipment, falling dirt, hose-directed water, the entry of water during prolonged submersion at a limited depth and damage from external ice formation.



### Ethernet for the layman

In order to explain basic Ethernet theory, we can use a functional comparison to a busy city with highways, buildings, and cars. To illustrate this, the table below provides correlation between the different components/pieces/links that encompass Ethernet network connectivity, and the larger scale infrastructure of a metropolitan city.

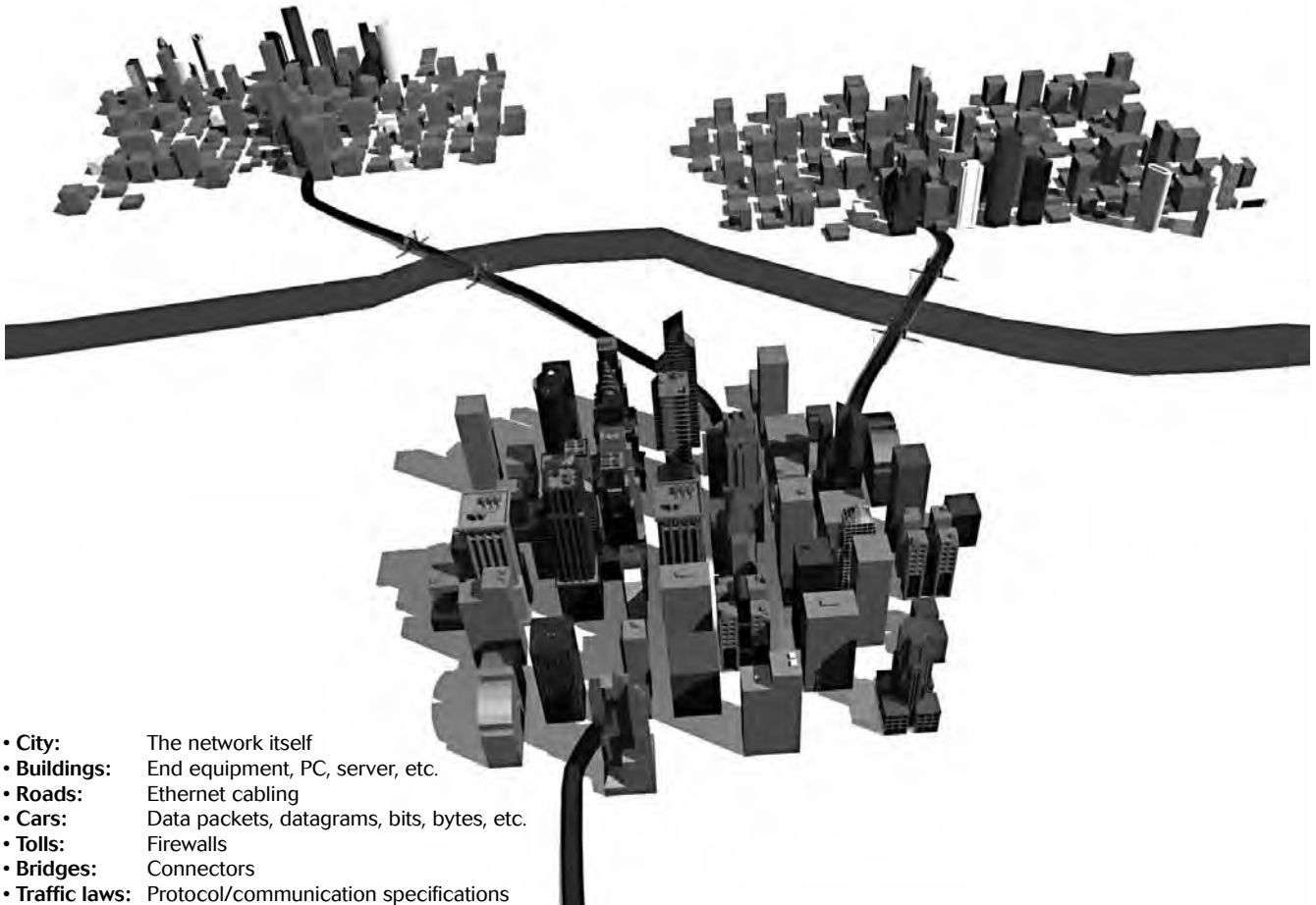

- **City:** The network itself
- **Buildings:** End equipment, PC, server, etc.
- **Roads:** Ethernet cabling
- **Cars:** Data packets, datagrams, bits, bytes, etc.
- **Tolls:** Firewalls
- **Bridges:** Connectors
- **Traffic laws:** Protocol/communication specifications

### Ethernet Basics

Ethernet is a widely used communications protocol that is used to transmit data packets (datagrams) between network devices. Imagine a highway in a large metropolitan area six lanes wide at rush hour. The vehicles on the highway need rules to follow so that they get to their destination without crashing into each other. In an Ethernet network link, there could be 100 million bits of information transmitted in one second. In the Ethernet standard, there exist rules to govern packet structure, transmission requirements, error correction, communication with end equipment, etc.

### Examining the differences between 100Mhz, 100 Base TX, Cat5e; what does it all mean?

When discussing connectors and Ethernet, there are a few key details to be aware of:

- 100Mhz is a measurement of Frequency for the signal
  - Comparable to the Speed Limit of a highway
- 100BaseTX (or Fast Ethernet) is an Ethernet link standard and identifies available link bandwidth. The bandwidth is measured in units of MBits/S (megabits per second)
  - Comparable to the number of cars that pass a point in one second
- Cat5e is an EIA/TIA standard for performance and physical characteristics for cables and connectors
  - Comparable to performance specifications of the car and highway

In connectors and cables, Fast Ethernet uses 2 pairs, one for transmit, one for receive. This way data traffic can flow in both directions simultaneously.



### Ethernet for the layman

#### Souriau offering:

Standard solutions.

UTS Hi seal size 8, 4 contacts

- 1 (Pair 1) < A
- 2 (Pair 1) < C
- 3 (Pair 2) < B
- 4 (Pair 2) < D

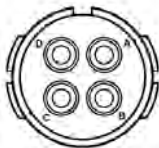

**8E4/8D4**  
4 Ø 1 (#20)

UTS size 10, 6 contacts

- 1 (Pair 1) < A
- 2 (Pair 1) < B
- 3 (Pair 2) < E
- 4 (Pair 2) < D



**106/10E6/10D6**  
6 Ø 1 (#20)

Shielding continuity done in cavity C&F.  
Note: Shielding can be replaced by DC power.

UTS size 12, 10 contacts

- 1 (Pair 1) < C
- 2 (Pair 1) < B
- 3 (Pair 2) < G
- 4 (Pair 2) < H

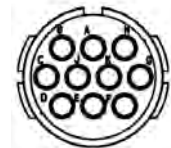

**12 10/12E 10/12D 10**  
10 Ø 1 (#20)

#### What about using coax contacts ?

Ethernet twisted pairs carry a symmetrical (balanced) signal. Once terminated into a coax contact, the inner core will be protected by a shield - but not the outer contact. Because of EMI issues, the signal will no longer be balanced. Conclusion - it does not work and is not recommended.

#### What about using Quadrax contacts ?

The Quadrax contact is used in railway applications because of the use of quad cable. In this specific market, the standard Ethernet twisted pairs wires cannot be offered, they are too thin and often solid (not stranded).

In the rest of industry, UTP (Unshielded Twisted Pairs) cables are widely used. The Quadrax contact is not designed to terminate them. And thus, are not advised for industrial applications.

#### Conclusion

To carry 100Mb/s data signal, 100BaseTX or Fast Ethernet recommends the use of Cat5e connectors as well as Cat5e cable with the support of a 100MHz signal. Nevertheless, a 100Mb/s signal can be transmitted in certain conditions (short distance, only one connector, lower frequency but a different code) thru many other connection materials - not necessarily Cat5e rated.

# UTS Series

Technical information





UNIT'S Series

# Appendices

- #16 coaxial contacts - cabling notices ..... 176
- Glossary of terms ..... 183
- Discrimination/Keying methods ..... 184
- Part number Index ..... 185







### #16 coaxial contacts

#### Coaxial cable - Contact monocrimp and multipiece

Cable type	Impedance	Contact type	Ø over jacket		Ø over dielectric		Inner cond size Ext. Ø mm	Ø outer braid		Male contact kit for coaxial cable	Female contact kit for coaxial cable
			inch	mm	inch	mm		inch	mm		
RG161/U	75	Multi piece	0.09	2.29	0.057	1.45				RMDXK10D28	RCDXK1D28
RG179A/U	75		0.105	2.67	0.063	1.6	0.3	0.084	2.13 max		
RG179B/U	75		0.105	2.67	0.063	1.6	0.3	0.084	2.13 max		
RG187/U	75		0.11	2.79 max	0.06	1.52	0.3				
RG188/U	50		0.11	2.79 max	0.06	1.52	0.51	0.078	1.98 max		
RG174/U	50		0.11	2.92	0.06	1.52	0.48	0.088	2.24 max		
AMPHENOL 21-598	50		0.105	2.67	0.06	1.52	0.48				
RG196/U	50		0.08	2.03 max	0.034	0.086	0.3				
RG178A/U	50		0.075	1.91	0.034	0.86	0.3	0.054	1.37 max		
RG188A/U	50	Mono crimp	0.110	2.79	0.06	1.52	0.51	0.078	1.98 max	RMDX6036D28	RCDX6036D28
KX21TVT (europe) RG178 B/U	50		0.075	1.91	0.034	0.86	0.3	0.054	1.37 max	RMDX6034D28	RCDX6034D28
RG178 / BU	50		0.075	1.91	0.034	0.86	0.3	0.054	1.37 max	RMDX6050D28	RCDX6016D28
RG174/U	50		0.115	2.92	0.06	1.52	0.48	0.088	2.24 max	RMDX6032D28	RCDX6032D28
RG188A/U	50		0.11	2.79	0.06	1.52	0.51	0.078	1.98 max	RMDX6036D28	RCDX6036D28
RG316/U	50		0.107	2.72	0.6	1.52	0.51	0.078	2.05 max	RMDX6036D28	RCDX6036D28
raychem 5024A3111	50		0.12	3.05	0.083	2.11	0.64	0.097	2.46	RMDX6052D28	RCDX6052D28
raychem 5026e1614	50		0.083	2.11	0.05	1.27	0.48	0.067	1.7	RMDX6036D28	RCDX6036D28
suprenant pn 8134	-		Multi piece	0.1	2.54	0.058	1.47	0.3			RMDXK10D28
PRD PN 247AS-C123-001	-	Mono crimp	0.103	2.62	0.06	1.52	0.51	0.078	1.98	RMDX6018D28	RCDX6018D28
PRD PN 247AS-C1251	-		0.092	2.34	0.05	1.27	0.64	0.067	1.7	RMDX6018D28	RCDX6018D28
JUDD C15013010902	-		0.087	2.13	0.05	1.27	0.48	0.066	1.67	RMDX6036D28	RCDX6036D28
CDC PIN22939200	-		0.09	2.29	0.048	1.22	0.3	0.064	1.63	RMDX6046D28	RCDX6016D28
CDC PIN22939200	-		0.09	2.29	0.048	1.22	0.3	0.064	1.63	RMDX6050D28	RCDX6016D28
CDC PIN245670000	-		0.104	2.64	0.067	1.7	0.3	0.083	2.11	RMDX6050D28	RCDX6016D28
ampex	-		0.114	2.9	0.075	1.91	0.38	0.09	1.29	RMDX6032D28	RCDX6032D28
TI PN 920580	-		0.7	1.78	0.038	0.96	0.48	0.054	1.37	RMDX6024D28	RCDX6024D28
Honeywell PN 58000062	-		0.12	3.05	0.077	1.96	0.41 solid	0.096	2.44	RMDX6026D28	RCDX6026D28
-	-		0.104	2.64	0.067	1.7	0.3		2.11	RMDX6050D28	-
-	-		0.09	2.29	0.048	1.22	0.3		1.63	RMDX6050D28	-
-	-		0.114	2.9	0.075	1.91	0.38		1.29	RMDX6032D28	RCDX6032D28
-	-		0.07	1.78	0.038	0.96	0.48		1.37	RMDX6024D28	RCDX6024D28
-	-		0.12	3.05	0.077	1.96	0.41		2.44	RMDX6026D28	RCDX6026D28



### Twisted cable - Contact monocrimp and multipiece

Cable type	Contact type	Inner AWG cond	Ø over jacket (single wire)		Inner cond size		Ø outer braid		Male contact kit for coaxial cable	Female contact kit for coaxial cable
			inch	mm	Stranded definition	Ext. Ø mm	inch	mm		
2#24 stranded mil w 16878 type B	Multi piece	24	0.049	1.24 max	7/.008		-	-	RMDXK10D28	RCDXK1D28
2 #24 solid mil-w-76 type LW		24	0.047	1.12 max	1/.0201		-	-	RMDXK10D28	RCDXK1D28
2 #26 stranded mil w 76 type LW or mil w16878 type b&e		26	0.043	1.09 max	7/.0063	0.16	-	-	RMDXK10D28	RCDXK1D28
2 #28 solid mil-w-81822/3		28	0.028	0.71 max			-	-	RMDXK10D28	RCDXK1D28
TWISTED PAIR 1/.201 SOLID MIL w 76 TYPE lw or MIL W 16878		26	0.044	1.12 max	1/.0201	0.511	-	-	RMDXK10D28	RCDXK1D28
twisted pair solid mil w 81822/3		28	0.028	0.71 max	1/.0126	0.32	-	-	RMDXK10D28	RCDXK1D28
#28 7/.0036 per Hitachi spec ec-711 (13-2820)	Mono crimp	-	0.046	1.17	7/.0036	-	-	-	RMDX6031D28 + YORX090	RCDX6031D28 + YORX090
20218201		-	0.028	0.71	-	-	-	-	RMDX6031D28 + YORX090	RCDX6031D28 + YORX090
#30 solid		-	0.025	0.64	-	-	-	-	RMDX6015D28 + YORX090	RCDX6015D28 + YORX090
#26 7/.0063		26	0.028	0.71	7/.063	0.16	-	-	RMDX6031D28 + YORX090	RCDX6031D28 + YORX090
#26 19/.004		26	0.049	1.24	19/.004	-	-	-	RMDX6019D28 + YORX090	RCDX6019D28 + YORX090
#24 7/.008		24	0.049	1.24	7/.008	-	-	-	RMDX6019D28 + YORX090	RCDX6019D28 + YORX090
#24 19/.005		24	0.057	1.45	19/.005	-	-	-	RMDX6019D28 + YORX090	RCDX6019D28 + YORX090
-		26	-	1.25	-	-	-	19x0.1	RMDX6019D28 + YORX090	RCDX6019D28 + YORX090
-		24	-	1.25	-	-	-	7x0.2	RMDX6019D28 + YORX090	RCDX6019D28 + YORX090
-		24	-	1.45	-	-	-	19x0.13	RMDX6019D28 + YORX090	RCDX6019D28 + YORX090
-		26	-	0.7	-	-	-	7x0.16	RMDX6031D28 + YORX090	RCDX6031D28 + YORX090



### #16 coaxial contacts

#### Twisted pair cable multipiece contact cabling

Cable reference	Contact type	Male contact	Female contact	Crimp tool	Die set	Stop bushing	Cable strip length			Inner conductor crimp		Braid crimp	
							A	B	C	g dim	t dim	g dim	t dim
2#24 stranded mil w 16878 type B	Multi piece	RMDXK10D28	RCDXK1D28	M10S1J	-	-				See assembly notice			
2 #24 solid mil-w-76 type LW													
2 #26 stranded mil w 76 type LW or mil w16878 type B & E													
2 #28 solid mil-w-81822/3													
twisted pair 1/.201 solid mil w 76 type LW or mil w 16878													
twisted pair solid mil w 81822/3													

#### Female contact

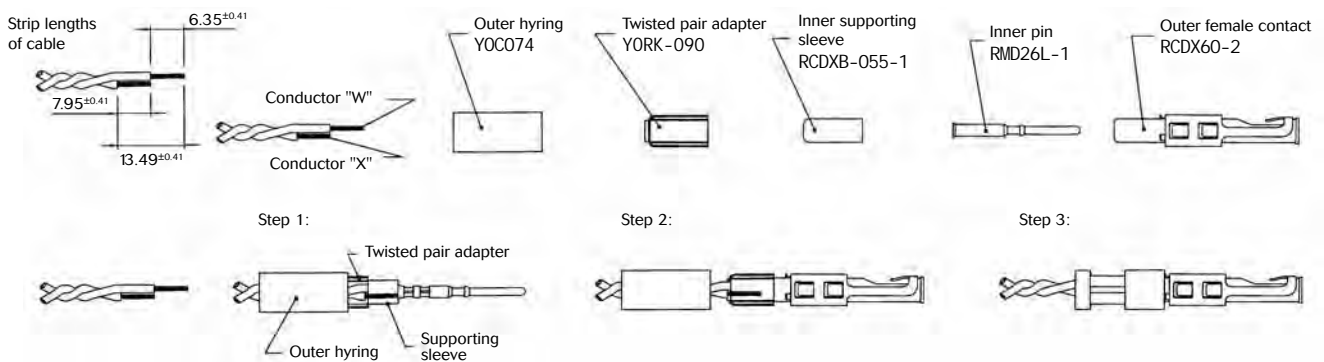

#### Male contact

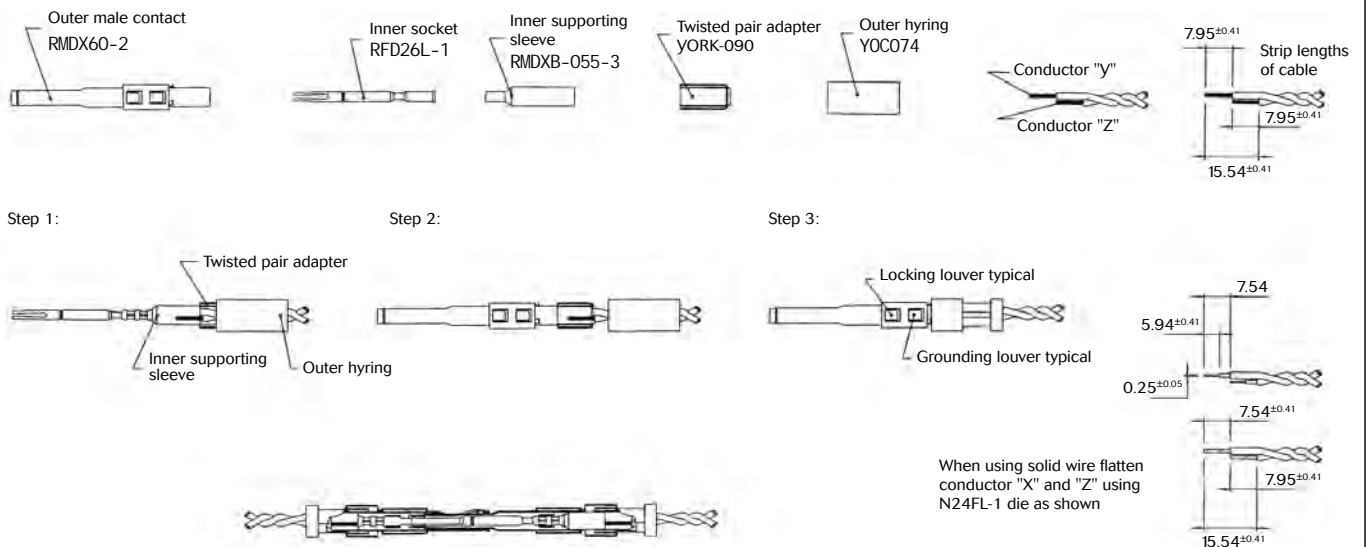

Note : all dimensions are in mm



### Twisted pair cable monocrimp contact cabling

Cable reference	Contact type	Male contact	Female contact	Crimp tool	Die set	Stop bushing	Cable strip length			Inner conductor crimp		Braid crimp	
							A	B	C	g dim	t dim	g dim	t dim
#28 7/0036 per Hitachi spec ec-711 (13-2820)	Mono crimp	RMDX6031D28 + YORX090	RCDX6031D28 + YORX090	M10S1J	S80	SL105	4.7	6.1	4.32	1.30 to 1.12	1.4 to 1.22	2.97 to 2.84	3.07 to 2.9
20218204					S80	SL105	3.94	6.1	3.16	1.30 to 1.17	1.4 to 1.22	2.97 to 2.84	3.07 to 2.79
#30 solid					S83	SL105	4.7	6.1	4.06	1.22 to 1.12	1.35 to 1.22	2.97 to 2.84	3.12 to 2.95
#26 7/0063					S80	SL105	4.7	6.1	4.06	1.30 to 1.17	1.4 to 1.22	2.97 to 2.84	3.07 to 2.9
#26 19/004					M10SG8 ASSY' Y TOOL DIE SET STOP BUSHING M10S1J TOOL	4.7	6.1	4.06	1.22 to 1.17	1.35 to 1.22	2.84 to 2.79	3.12 to 2.97	
#24 7/008						4.7	6.1	4.06	1.22 to 1.17	1.35 to 1.22	2.84 to 2.79	3.12 to 2.97	
#24 19/005						4.7	6.1	4.06	1.22 to 1.17	1.35 to 1.22	2.84 to 2.79	3.12 to 2.97	
AWG26 (19x0.1)					M10SG8 crimping kit	4.7	6	4	/		/		
AWG24 (7x0.2)													
AWG24 (19x0.13)													
AWG26 (7x0.16)													
									S80	SL150			

- Select appropriate monocrimp coax twisted pair contact and cable combination.
- Select appropriate crimp tooling (hand tool, S-die set, stop bushing).
- Strip the twisted pair cable to the designated wire strip lengths.
- Insert the stripped cable into the contact. One cable is to be inserted into the inside diameter of hyring, and pushed forward into the inner contact. The second cable is to be inserted between the outside diameter of hyring and the inside diameter of the outer contact body.
- Crimp the contact.

Cable strip length

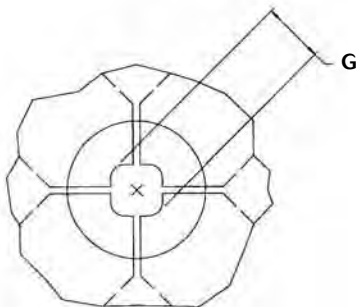
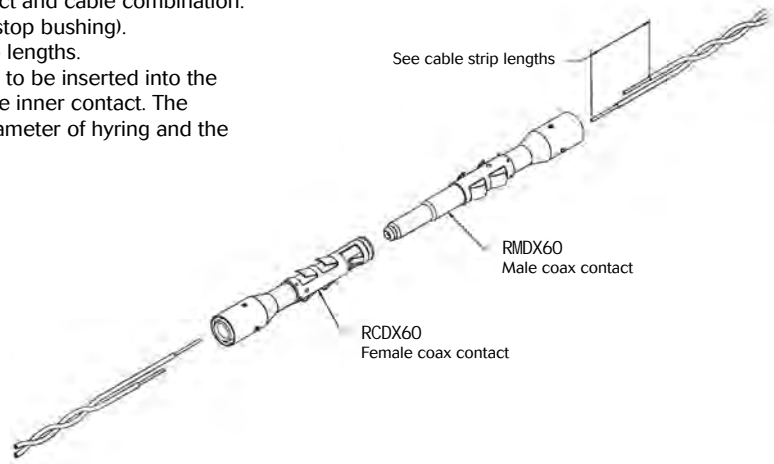
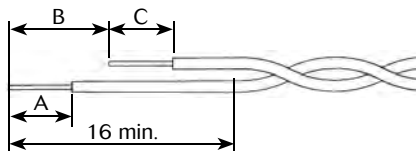

Braid crimp (G) to be measured with die set fully closed

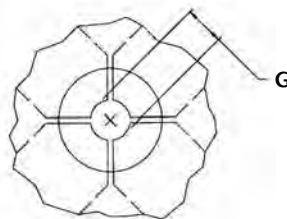

Inner conductor crimp (G) to be measured with die set fully closed

Note : all dimensions are in mm



### #16 coaxial contacts

#### Multipiece male contact with coax cable

Cable reference	Contact	Hyring complementary components	Outer contact crimp tool		Inner contact crimp tool		Cable strip length		
			Crimp tool M10S1J		Crimp tool M10S1J		A	B	C
			Die set	Stop bushing	Die set	Stop bushing			
RG161U	Male: RMDXK10D28	YOC074	S221	SL471	S23D2	SL46D2	4.37	7.95	15.88
RG179							4.37	7.95	15.88
RG187U							4.37	7.95	15.88
RG188/U							4.37	7.95	15.88
RG174/U		YOC074 + RMDXB0553			S23D2		7.54	9.12	17.53
RG178A/U					S23D2		7.54	9.12	17.53
RG196U		YOC074			-		4.37	7.95	15.88
AMPHENOL 21-598					-		4.37	7.95	15.88
surprenant pn 8134						4.37	7.95	15.88	

#### Multipiece kit details

RMDXK10D28 includes	Component	Description
	RMDX602D28	Outer contact
	RFD26L1D28	Inner contact
	YOC074	Outer hyring
	RMDXB0553	Inner supporting sleeve

#### Cable strip length

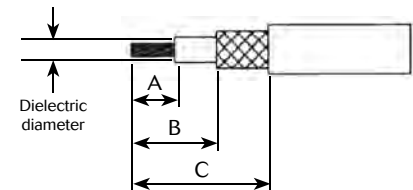

#### Contact assembly with dielectric diameter over 1.4mm - without inner supporting sleeve

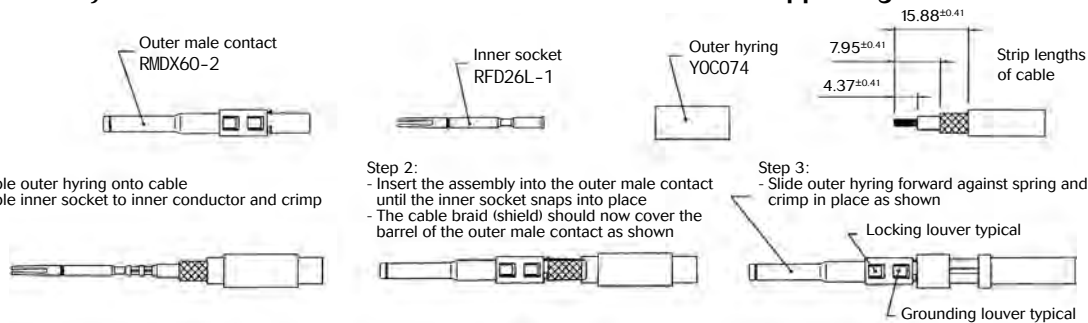

#### Contact assembly with dielectric diameter under 1.4mm - with inner supporting sleeve

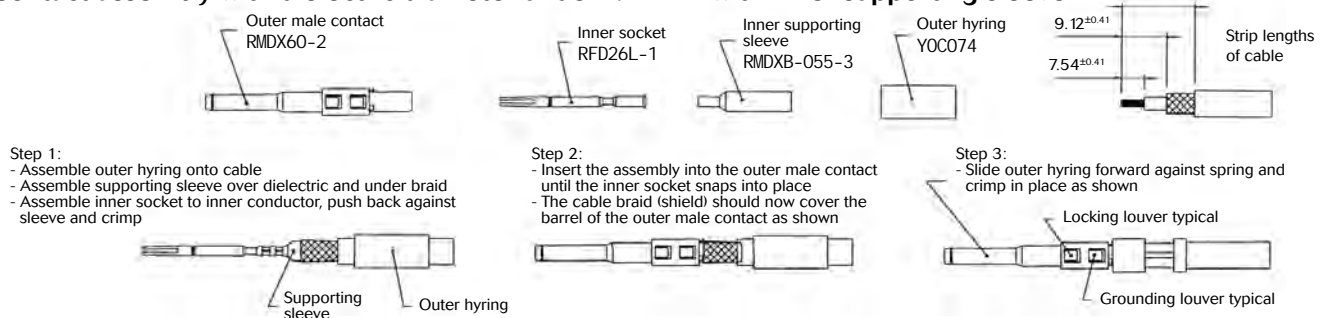

Note : all dimensions are in mm



### Multipiece female contact with coax cable

Cable reference	Contact	Hyring complementary components	Outer contact crimp tool		Inner contact crimp tool		Cable strip length		
			Crimp tool M10S1J		Crimp tool M10S1J		A	B	C
			Die set	Stop bushing	Die set	Stop bushing			
RG161U	Female: RCDXK1D28	YOC074	S221	SL471	S23D2	SL46D2	4.37	-	11.13
RG179							4.37		11.13
RG187U							4.37		11.13
RG188/U							4.37		11.13
RG174/U		YOC074 + RMDXB0553			6.35		11.13		
RG178A/U					6.35		11.13		
RG196U					6.35		11.13		
AMPHENOL 21-598		YOC074			-		4.37		11.13
surprenant pn 8134					-		4.37		11.13

#### Multipiece kit details

RCDXK1D28 includes	RCDX602D28	Outer contact
	RMD26L1D28	Inner contact
	YOC074	Outer hyring
	RCDXB0553	Inner supporting sleeve

#### Cable strip length

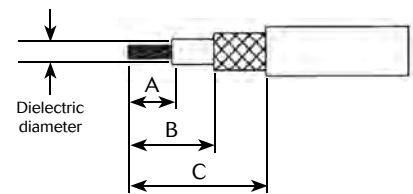

#### Contact assembly with dielectric diameter over 1.4mm - without inner supporting sleeve

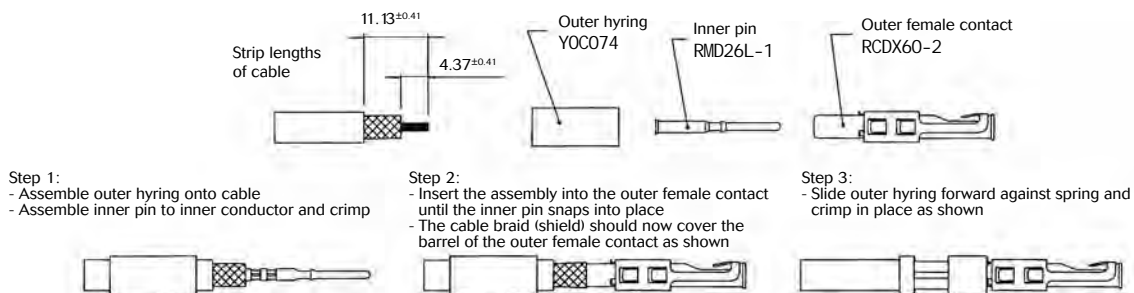

#### Contact assembly with dielectric diameter under 1.4mm - with inner supporting sleeve

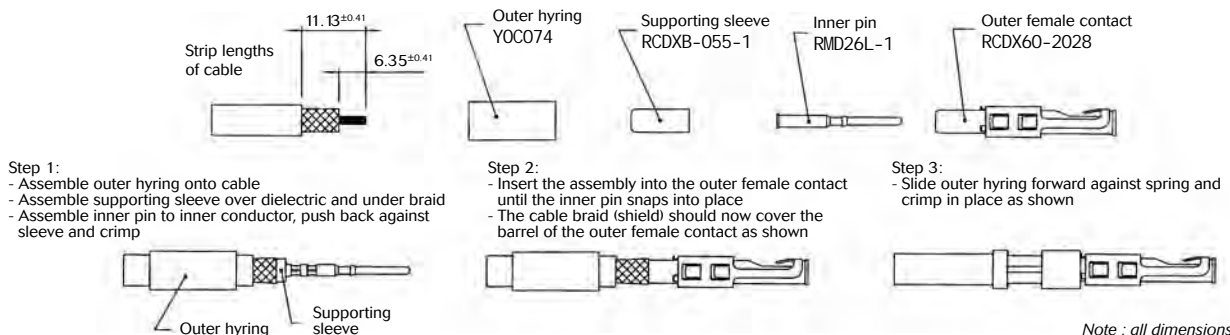

Note : all dimensions are in mm



### #16 coaxial contacts

#### Coax cable with monocrimp contact cabling

Cable reference	Male contact	Female contact	Crimp tool	Die set	Stop bushing	Cable strip length			Inner conductor crimp		Braid crimp	
						A	B	C	g dim	t dim	g dim	t dim
CDC PIN22939200	RMDX6046D28	RCDX6016D28	M10S1J	S80	SL105	4.19	5.97	8.51	1.30/1.17	1.40/1.22	2.77/2.64	3.02/2.84
CDC PIN22939200	RMDX6046D28	RCDX6016D28		S87	SL105	5.08	6.35	8.89	1.30/1.17	1.40/1.22	2.77/2.64	3.02/2.84
CDC PIN245670000	RMDX6050D28	RCDX6016D28		S80	SL105	5.08	6.35	8.89	1.30/1.17	1.40/1.22	2.97/2.84	3.12/2.95
KX21TVT (europe) RG178 B/U	RMDX6034D28	RCDX6034D28		S82	SL105	5.08	6.35	8.89	1.30/1.17	1.32/1.17	2.84/2.74	3.07/2.9
RG178 / BU	RMDX6050D28	RCDX6016D28		S87	SL105	5.08	6.35	8.89	1.30/1.17	1.40/1.22	2.77/2.64	3.02/2.84
ampex	RMDX6032D28	RCDX6032D28		S80	SL105	5.08	6.35	11.68	1.30/1.17	1.40/1.22	2.97/2.84	3.12/2.95
TI PN 920580	RMDX6024D28	RCDX6024D28		S82	SL105	5.08	6.35	8.89	1.35/1.19	1.42/1.27	2.87/2.74	3.07/2.9
RG174/U	RMDX6032D28	RCDX6032D28		S80	SL105	5.08	6.35	11.68	1.30/1.17	1.40/1.22	2.97/2.84	3.12/2.95
Honeywell PN 58000062	RMDX6026D28	RCDX6026D28		S82	SL105	5.08	6.35	8.89	1.35/1.19	1.42/1.27	2.87/2.74	3.07/2.9
RG188A/U	RMDX6036D28	RCDX6036D28		S80	SL105	5.08	6.35	11.68	1.30/1.17	1.40/1.22	2.97/2.84	3.12/2.95
RG316/U	RMDX6036D28	RCDX6036D28		S80	SL105	5.08	6.35	11.68	1.30/1.17	1.40/1.22	2.97/2.84	3.12/2.95
PRD PN 247AS-C123-001	RMDX6018D28	RCDX6018D28		M10SG8 ASSY' Y TOOL DIE SET STOP BUSHING M10S1J TOOL		5.08	6.35	8.89	1.22/1.17	1.35/1.22	2.92/2.79	3.12/2.97
PRD PN 247AS-C1251	RMDX6018D28	RCDX6018D28		M10S1J TOOL		5.08	6.35	8.89	1.22/1.17	1.35/1.22	2.92/2.79	3.12/2.97
raychem 5024A3111	RMDX6052D28	RCDX6052D28		S88	SL105	5.08	6.35	11.68	1.37/1.27	1.45/1.32	2.92/2.79	
raychem 5026e1614	RMDX6036D28	RCDX6036D28		M10SG8 ASSY' Y TOOL DIE SET STOP BUSHING M10S1J TOOL		5.08	6.35	8.89	1.22/1.17	1.35/1.22	2.92/2.79	3.12/2.97
JUDD C15013010902	RMDX6036D28	RCDX6036D28		M10S1J TOOL		5.08	6.35	8.89	1.22/1.17	1.35/1.22	2.92/2.79	3.12/2.97
inner cond. #30, braid diam 2.64	RMDX6050D28	-		S80	SL105	5.1	6.35	8.9	-	-	-	-
inner cond. #30, braid diam 2.29	RMDX6050D28	-		S87	SL105	4.2	6.35	8.5	-	-	-	-
inner cond. #28, braid diam 2.9	RMDX6032D28	RCDX6032D28		S80	SL105	5.1	6.35	11.7	-	-	-	-
inner cond. #26, braid diam 1.78	RMDX6024D28	RCDX6024D28		S82	SL105	5.1	6.35	8.9	-	-	-	-
inner cond. #26, braid diam 3.05	RMDX6026D28	RCDX6026D28	S82	SL105	5.1	6.35	8.9	-	-	-	-	

- Select appropriate cable and contact combination.
- Select appropriate crimp tooling (hand tool, S-die set, stop bushing).
- Strip coax cable to the designated wire strip lengths.
- Insert the stripped coax into the rear of the contact.
- Crimp the contact.

Cable strip length

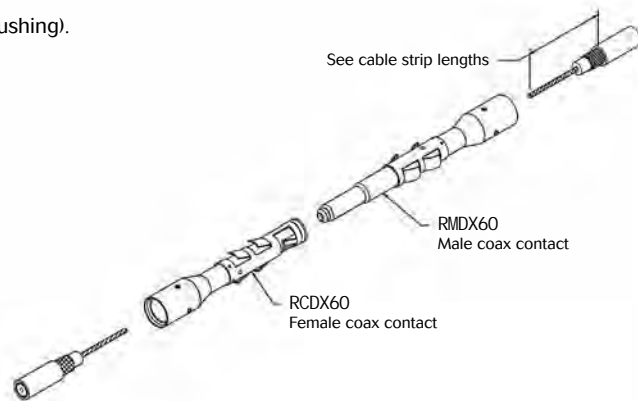
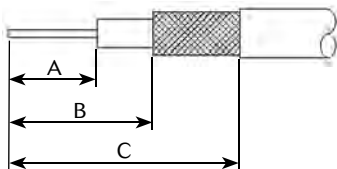

Note : all dimensions are in mm



### Glossary of terms

• **Clearance**

Per the IEC 60664-1 it is the shortest distance between two conductive parts even over the air.

• **Creepage distance**

Per the IEC 60664-1 it represents the shortest distance along the surface of the insulating material between two conductive parts.

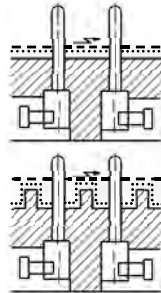

--- Air gap  
..... Creepage distance

• **Working voltage**

Per the IEC 60664-1 it is the highest r.m.s. value of A.C. or D.C. voltage across any particular insulation which can occur when the equipment is supplied at rated voltage.

• **Rated impulse voltage**

Impulse withstands voltage value assigned by the manufacturer to the equipment or to a part of it characterizing the specified withstand capability of its insulation against transient overvoltage.

• **Working current**

It is the maximum continuous and not interrupted current able to be carried by all contacts without exceeding the maximum temperature of the insulating material.

• **Transient voltage**

Extract from the IEC 60664-1: Short duration overvoltage of a few millisecond or less, oscillatory or non-oscillatory, usually highly damped.

• **CTI (Comparative Tracking Index)**

The CTI value is commonly used to characterize the electrical breakdown properties of an insulating material. It allows users to know the tendency to create creepage paths. This value represents the maximum voltage after 50 drops of ammonium chloride solution without any breakdown.

• **RTI (Relative temperature Index):**

Extract from ULs website:

“Maximum service temperature for a material, where a class of critical property will not be unacceptably compromised through chemical thermal degradation, over the reasonable life of an electrical product, relative to a reference material having a confirmed, acceptable corresponding performance defined RTI.

- **RTI Elec:** Electrical RTI, associated with critical electrical insulating properties.

- **RTI Mech Imp:** Mechanical Impact RTI, associated with critical impact resistance, resilience and flexibility properties.

- **RTI Mech Str:** Mechanical Strength (Mechanical without Impact) RTI, associated with critical mechanical strength where impact resistance, resilience and flexibility are not essential”



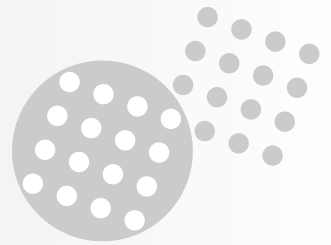

### Discrimination/Keying methods

In applications where similar connectors are used next to each other, mismatching can be a reason for disturbances, system failure or even danger to operating personnel.

To eliminate mismatching, all TRIM TRIO® connectors can be equipped with discrimination keys, which offer unlimited possibilities for an error avoiding interconnection system.

The other way around is to rotate the insert into the shell.

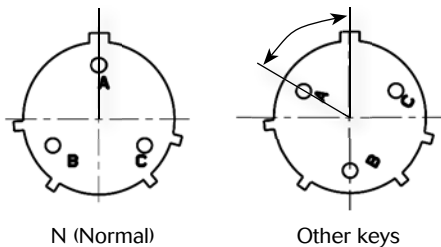

*Note: Insert rotated in body  
(viewed from front face of male insert)*

Connectors with rotated inserts can be ordered by adding the suffix W, X, Y or Z to the standard part number.

e.g. UTS6JC104S (N key) → UTS6JC104SW (W key)

Shell size	Layout	Discrimination keys degrees			
		W	X	Y	Z
8	8E2	58°	122°		
	8E3 8E3A	60°	210°		
	8E4	45°			
	8E33	90°			
10	102W2 103 104				
	106 10E6 10E7	90°			
	10E98	90°	180°	240°	270°
12	12E2				
	12E3			180°	
	124 128				
	12E8	90°	112°	203°	292°
	1210 12E10	60°	155°	270°	295°
	12E14	45°			
14	14E5	40°	92°	184°	273°
	142G1 147				
	1412	60°			
	14E12	43°	90°		
	14E15	17°	110°	155°	234°
	14E18	15°	90°	180°	270°
	1419	30°	165°	315°	
	14E19	30°	165°	315°	
18	18E11	62°	119°	241°	340°
	1823		158°		270°
	18E30	180°	193°	285°	350°
	1832 18E32	85°	138°	222°	265°



### Part number Index

#### Mechanics

UTS0104P.....	P. 68	UTS014D5P.....	P. 120	UTS1GJC147P.....	P. 88
UTS0104S.....	P. 68	UTS014D5S.....	P. 120	UTS1GN104P.....	P. 68
UTS010D6P.....	P. 68	UTS014E12P.....	P. 112	UTS1GN128P.....	P. 96
UTS010D6S.....	P. 68	UTS014E12S.....	P. 112	UTS1GN1412P.....	P. 108
UTS010D7P.....	P. 68	UTS014E15P.....	P. 120	UTS1GN147P.....	P. 88
UTS010D7S.....	P. 68	UTS014E15S.....	P. 120	UTS1JC102W2P.....	P. 64
UTS010D98P.....	P. 84	UTS014E18P.....	P. 124	UTS1JC102W2S.....	P. 64
UTS010D98S.....	P. 84	UTS014E18S.....	P. 124	UTS1JC103P.....	P. 40
UTS010E6P.....	P. 80	UTS014E19P.....	P. 128	UTS1JC103S.....	P. 40
UTS010E6S.....	P. 80	UTS014E19S.....	P. 128	UTS1JC103W3P.....	P. 40
UTS010E7P.....	P. 92	UTS014E5P.....	P. 120	UTS1JC103W3S.....	P. 40
UTS010E7S.....	P. 92	UTS014E5S.....	P. 120	UTS1JC104P.....	P. 68
UTS010E98P.....	P. 84	UTS014E7P.....	P. 88	UTS1JC104S.....	P. 68
UTS010E98S.....	P. 84	UTS014E7S.....	P. 88	UTS1JC106P.....	P. 80
UTS0124P.....	P. 52	UTS01823P.....	P. 132	UTS1JC106S.....	P. 80
UTS0128P.....	P. 96	UTS01823S.....	P. 132	UTS1JC1210P.....	P. 104
UTS0128S.....	P. 96	UTS08D2P.....	P. 20	UTS1JC1210S.....	P. 104
UTS012D10P.....	P. 104	UTS08D2P.....	P. 20	UTS1JC124P.....	P. 52
UTS012D10S.....	P. 104	UTS08D2S.....	P. 20	UTS1JC124PSCR.....	P. 52
UTS012D14P.....	P. 116	UTS08D2S.....	P. 20	UTS1JC124S.....	P. 52
UTS012D14S.....	P. 116	UTS08D33P.....	P. 44	UTS1JC128P.....	P. 96
UTS012D2P.....	P. 24	UTS08D33P.....	P. 44	UTS1JC128S.....	P. 96
UTS012D2S.....	P. 24	UTS08D33S.....	P. 44	UTS1JC1412P.....	P. 108
UTS012D3P.....	P. 48	UTS08D33S.....	P. 44	UTS1JC1412S.....	P. 108
UTS012D3S.....	P. 48	UTS08D3AP.....	P. 36	UTS1JC1419P.....	P. 128
UTS012D4P.....	P. 68	UTS08D3AS.....	P. 36	UTS1JC1419S.....	P. 128
UTS012D4S.....	P. 68	UTS08D3P.....	P. 36	UTS1JC142G1P.....	P. 32
UTS012D8P.....	P. 100	UTS08D3P.....	P. 36	UTS1JC142G1S.....	P. 32
UTS012D8S.....	P. 100	UTS08D3S.....	P. 36	UTS1JC147P.....	P. 88
UTS012E10P.....	P. 104	UTS08D3S.....	P. 36	UTS1JC147PSCR.....	P. 88
UTS012E10S.....	P. 104	UTS08D4P.....	P. 60	UTS1JC147S.....	P. 88
UTS012E14P.....	P. 116	UTS08D4P.....	P. 60	UTS1JC1823P.....	P. 132
UTS012E14S.....	P. 116	UTS08D4S.....	P. 60	UTS1JC1823S.....	P. 132
UTS012E2P.....	P. 24	UTS08D4S.....	P. 60	UTS1JC1832P.....	P. 136
UTS012E2S.....	P. 24	UTS08D98P.....	P. 40	UTS1JC1832S.....	P. 136
UTS012E3P.....	P. 48	UTS08D98S.....	P. 40	UTS6102W2P.....	P. 64
UTS012E3S.....	P. 48	UTS08E2P.....	P. 20	UTS6102W2S.....	P. 64
UTS012E4P.....	P. 52	UTS08E2S.....	P. 20	UTS6103P.....	P. 40
UTS012E4S.....	P. 52	UTS08E33P.....	P. 44	UTS6103S.....	P. 40
UTS012E8P.....	P. 100	UTS08E33S.....	P. 44	UTS6103W3P.....	P. 40
UTS012E8S.....	P. 100	UTS08E3AP.....	P. 40	UTS6103W3S.....	P. 40
UTS01412P.....	P. 108	UTS08E3AS.....	P. 40	UTS6104P.....	P. 68
UTS01412S.....	P. 108	UTS08E3P.....	P. 36	UTS6104S.....	P. 68
UTS0147P.....	P. 88	UTS08E3S.....	P. 36	UTS6106P.....	P. 80
UTS014D12P.....	P. 112	UTS08E4P.....	P. 60	UTS6106S.....	P. 80
UTS014D12S.....	P. 112	UTS08E4S.....	P. 60	UTS610E6P.....	P. 80
UTS014D15P.....	P. 120	UTS08E98P.....	P. 40	UTS610E6S.....	P. 80
UTS014D15S.....	P. 120	UTS08E98S.....	P. 40	UTS610E7P.....	P. 92
UTS014D18P.....	P. 124	UTS1GJC104P.....	P. 68	UTS610E7S.....	P. 92
UTS014D18S.....	P. 124	UTS1GJC128P.....	P. 96	UTS610E98P.....	P. 84
		UTS1GJC1412P.....	P. 108	UTS610E98S.....	P. 84

# UTS Series

## Appendices



UTS61210P.....	P. 104	UTS68E98P.....	P. 40	UTS6JC142G1S.....	P. 32
UTS61210S.....	P. 104	UTS68E98S.....	P. 40	UTS6JC147P.....	P. 88
UTS6124P.....	P. 52	UTS6GJC104S.....	P. 68	UTS6JC147PSCR.....	P. 88
UTS6124S.....	P. 52	UTS6GJC128S.....	P. 96	UTS6JC147S.....	P. 88
UTS6128P.....	P. 96	UTS6GJC1412S.....	P. 108	UTS6JC147SSCR.....	P. 88
UTS6128S.....	P. 96	UTS6GJC147S.....	P. 88	UTS6JC14E12P.....	P. 112
UTS612E10P.....	P. 104	UTS6GN104S.....	P. 68	UTS6JC14E12S.....	P. 112
UTS612E10S.....	P. 104	UTS6GN128S.....	P. 96	UTS6JC14E15P.....	P. 120
UTS612E14P.....	P. 116	UTS6GN1412S.....	P. 108	UTS6JC14E15S.....	P. 120
UTS612E14S.....	P. 116	UTS6GN147S.....	P. 88	UTS6JC14E18P.....	P. 124
UTS612E2P.....	P. 24	UTS6JC102W2P.....	P. 64	UTS6JC14E18S.....	P. 124
UTS612E2S.....	P. 24	UTS6JC102W2S.....	P. 64	UTS6JC14E19P.....	P. 128
UTS612E3P.....	P. 48	UTS6JC103P.....	P. 40	UTS6JC14E19S.....	P. 128
UTS612E3S.....	P. 48	UTS6JC103S.....	P. 40	UTS6JC14E5P.....	P. 72
UTS612E4P.....	P. 52	UTS6JC103W3P.....	P. 40	UTS6JC14E5S.....	P. 72
UTS612E4S.....	P. 52	UTS6JC103W3S.....	P. 40	UTS6JC14E7P.....	P. 88
UTS612E8P.....	P. 100	UTS6JC104P.....	P. 68	UTS6JC14E7S.....	P. 88
UTS612E8S.....	P. 100	UTS6JC104S.....	P. 68	UTS6JC1823P.....	P. 132
UTS61412P.....	P. 108	UTS6JC106P.....	P. 80	UTS6JC1823S.....	P. 132
UTS61412S.....	P. 108	UTS6JC106S.....	P. 80	UTS6JC1832P.....	P. 136
UTS61419P.....	P. 128	UTS6JC10E6P.....	P. 80	UTS6JC1832S.....	P. 136
UTS61419S.....	P. 128	UTS6JC10E6S.....	P. 80	UTS6JC183G1P.....	P. 56
UTS6142G1P.....	P. 32	UTS6JC10E7P.....	P. 92	UTS6JC8E2P.....	P. 20
UTS6142G1S.....	P. 32	UTS6JC10E7S.....	P. 92	UTS6JC8E2S.....	P. 20
UTS6147P.....	P. 88	UTS6JC10E98P.....	P. 84	UTS6JC8E33P.....	P. 44
UTS6147S.....	P. 88	UTS6JC10E98S.....	P. 84	UTS6JC8E33S.....	P. 44
UTS614E12P.....	P. 112	UTS6JC1210P.....	P. 104	UTS6JC8E3AP.....	P. 40
UTS614E12S.....	P. 112	UTS6JC1210S.....	P. 104	UTS6JC8E3AS.....	P. 40
UTS614E15P.....	P. 120	UTS6JC124P.....	P. 52	UTS6JC8E3P.....	P. 36
UTS614E15S.....	P. 120	UTS6JC124PSCR.....	P. 52	UTS6JC8E3S.....	P. 36
UTS614E18P.....	P. 124	UTS6JC124S.....	P. 52	UTS6JC8E4P.....	P. 60
UTS614E18S.....	P. 124	UTS6JC124SSCR.....	P. 52	UTS6JC8E4S.....	P. 60
UTS614E19P.....	P. 128	UTS6JC128P.....	P. 96	UTS6JC8E98P.....	P. 40
UTS614E19S.....	P. 128	UTS6JC128S.....	P. 96	UTS6JC8E98S.....	P. 40
UTS614E5P.....	P. 72	UTS6JC12E10P.....	P. 104	UTS7102W2P.....	P. 64
UTS614E5S.....	P. 72	UTS6JC12E10S.....	P. 104	UTS7102W2S.....	P. 64
UTS61823P.....	P. 132	UTS6JC12E14P.....	P. 116	UTS7103P.....	P. 40
UTS61823S.....	P. 132	UTS6JC12E14S.....	P. 116	UTS7103S.....	P. 40
UTS61832P.....	P. 136	UTS6JC12E2P.....	P. 24	UTS7103W3P.....	P. 40
UTS61832S.....	P. 136	UTS6JC12E2S.....	P. 24	UTS7103W3S.....	P. 40
UTS6183G1P.....	P. 56	UTS6JC12E3P.....	P. 48	UTS7104P.....	P. 68
UTS68E2P.....	P. 20	UTS6JC12E3S.....	P. 48	UTS7104S.....	P. 68
UTS68E2S.....	P. 20	UTS6JC12E4P.....	P. 52	UTS7106P.....	P. 80
UTS68E33P.....	P. 44	UTS6JC12E4S.....	P. 52	UTS7106S.....	P. 80
UTS68E33S.....	P. 44	UTS6JC12E8P.....	P. 100	UTS710D6P.....	P. 80
UTS68E3AP.....	P. 40	UTS6JC12E8S.....	P. 100	UTS710D6P32.....	P. 80
UTS68E3AS.....	P. 40	UTS6JC1412P.....	P. 108	UTS710D6S.....	P. 80
UTS68E3P.....	P. 36	UTS6JC1412S.....	P. 108	UTS710D6S32.....	P. 80
UTS68E3S.....	P. 36	UTS6JC1419P.....	P. 128	UTS710D7P.....	P. 92
UTS68E4P.....	P. 60	UTS6JC1419S.....	P. 128	UTS710D7P32.....	P. 92
UTS68E4S.....	P. 60	UTS6JC142G1P.....	P. 32	UTS710D7S.....	P. 92

# UTS Series

## Appendices



UTS710D7S32.....	P. 92	UTS712E2P.....	P. 24	UTS714E7S.....	P. 88
UTS710D98P.....	P. 84	UTS712E2S.....	P. 24	UTS71823P.....	P. 132
UTS710D98P32.....	P. 84	UTS712E3P.....	P. 48	UTS71823S.....	P. 132
UTS710D98S.....	P. 84	UTS712E3S.....	P. 48	UTS71832P.....	P. 136
UTS710D98S32.....	P. 84	UTS712E4P.....	P. 52	UTS71832S.....	P. 136
UTS710E6P.....	P. 80	UTS712E4S.....	P. 52	UTS7183G1SNPT.....	P. 56
UTS710E6S.....	P. 80	UTS712E8P.....	P. 100	UTS78D2P.....	P. 20
UTS710E7P.....	P. 92	UTS712E8S.....	P. 100	UTS78D2P32.....	P. 20
UTS710E7S.....	P. 92	UTS71412P.....	P. 108	UTS78D2S.....	P. 20
UTS710E98P.....	P. 84	UTS71412S.....	P. 108	UTS78D2S32.....	P. 20
UTS710E98S.....	P. 84	UTS71419P.....	P. 128	UTS78D33P.....	P. 44
UTS71210P.....	P. 104	UTS71419S.....	P. 128	UTS78D33P32.....	P. 44
UTS71210S.....	P. 104	UTS7142G1P.....	P. 32	UTS78D33S.....	P. 44
UTS7124P.....	P. 52	UTS7142G1S.....	P. 32	UTS78D33S32.....	P. 44
UTS7124PSCR.....	P. 52	UTS7142G1SNPT.....	P. 32	UTS78D3AP.....	P. 40
UTS7124S.....	P. 52	UTS7147P.....	P. 88	UTS78D3AP32.....	P. 40
UTS7124SSCR.....	P. 52	UTS7147PSCR.....	P. 88	UTS78D3AS.....	P. 40
UTS7128P.....	P. 96	UTS7147PSEK9.....	P. 88	UTS78D3AS32.....	P. 40
UTS7128PSEK9.....	P. 96	UTS7147S.....	P. 88	UTS78D3P.....	P. 36
UTS7128S.....	P. 96	UTS7147SSCR.....	P. 88	UTS78D3P32.....	P. 36
UTS712CCRG.....	P. 26	UTS714D12P.....	P. 112	UTS78D3S.....	P. 36
UTS712CCRR.....	P. 26	UTS714D12P32.....	P. 112	UTS78D3S32.....	P. 36
UTS712CCRY.....	P. 26	UTS714D12S.....	P. 112	UTS78D4P.....	P. 60
UTS712D10P.....	P. 104	UTS714D12S32.....	P. 112	UTS78D4P32.....	P. 60
UTS712D10P32.....	P. 104	UTS714D15P.....	P. 120	UTS78D4S.....	P. 60
UTS712D10S.....	P. 104	UTS714D15P32.....	P. 120	UTS78D4S32.....	P. 60
UTS712D10S32.....	P. 104	UTS714D15S.....	P. 120	UTS78D98P.....	P. 40
UTS712D14P.....	P. 116	UTS714D15S32.....	P. 120	UTS78D98P32.....	P. 40
UTS712D14P32.....	P. 116	UTS714D18P.....	P. 124	UTS78D98S.....	P. 40
UTS712D14S.....	P. 116	UTS714D18P32.....	P. 124	UTS78D98S32.....	P. 40
UTS712D14S32.....	P. 116	UTS714D18S.....	P. 124	UTS78E2P.....	P. 20
UTS712D2P.....	P. 24	UTS714D18S32.....	P. 124	UTS78E2S.....	P. 20
UTS712D2P32.....	P. 24	UTS714D19P.....	P. 128	UTS78E33P.....	P. 44
UTS712D2S.....	P. 24	UTS714D19P32.....	P. 128	UTS78E33S.....	P. 44
UTS712D2S32.....	P. 24	UTS714D19S.....	P. 128	UTS78E3AP.....	P. 40
UTS712D3P.....	P. 48	UTS714D19S32.....	P. 128	UTS78E3AS.....	P. 40
UTS712D3P32.....	P. 48	UTS714D5P.....	P. 120	UTS78E3P.....	P. 36
UTS712D3S.....	P. 48	UTS714D5P32.....	P. 120	UTS78E3S.....	P. 36
UTS712D3S32.....	P. 48	UTS714D5S.....	P. 120	UTS78E4P.....	P. 60
UTS712D4P.....	P. 52	UTS714D5S32.....	P. 120	UTS78E4S.....	P. 60
UTS712D4P32.....	P. 52	UTS714E12P.....	P. 112	UTS78E98P.....	P. 40
UTS712D4S.....	P. 52	UTS714E12S.....	P. 112	UTS78E98S.....	P. 40
UTS712D4S32.....	P. 52	UTS714E15P.....	P. 120	UTS7GJC104P.....	P. 68
UTS712D8P.....	P. 100	UTS714E15S.....	P. 120	UTS7GJC128P.....	P. 96
UTS712D8P32.....	P. 100	UTS714E18P.....	P. 124	UTS7GJC1412P.....	P. 108
UTS712D8S.....	P. 100	UTS714E18S.....	P. 124	UTS7GJC147P.....	P. 88
UTS712D8S32.....	P. 100	UTS714E19P.....	P. 128	UTS7GN104P.....	P. 68
UTS712E10P.....	P. 104	UTS714E19S.....	P. 128	UTS7GN128P.....	P. 96
UTS712E10S.....	P. 104	UTS714E5P.....	P. 72	UTS7GN1412P.....	P. 108
UTS712E14P.....	P. 116	UTS714E5S.....	P. 72	UTS7GN147P.....	P. 88
UTS712E14S.....	P. 116	UTS714E7P.....	P. 88		



### Accessories

85005585A.....	P. 22
85005586A.....	P. 30
85005587A.....	P. 26
85005588A.....	P. 34
85005590A.....	P. 134
85005594.....	P. 22
85005595.....	P. 30
85005596.....	P. 26
85005597.....	P. 34
85005599.....	P. 134
UT610CCRG.....	P. 30
UT610CCRR.....	P. 30
UT610CCRY.....	P. 30
UT612CCRG.....	P. 26
UT612CCRR.....	P. 26
UT612CCRY.....	P. 26
UT614CCRG.....	P. 34
UT614CCRR.....	P. 34
UT614CCRY.....	P. 34
UTFD11B.....	P. 22
UTFD12B.....	P. 30
UTFD13B.....	P. 26
UTFD14B.....	P. 34
UTFD16B.....	P. 134
UTS10DCG.....	P. 30
UTS10DCGE.....	P. 30
UTS10DCGR.....	P. 30
UTS12DCG.....	P. 26
UTS12DCGE.....	P. 26
UTS12DCGR.....	P. 26
UTS14DCG.....	P. 34
UTS14DCGE.....	P. 34
UTS14DCGR.....	P. 34
UTS18DCG.....	P. 134
UTS18DCGE.....	P. 134
UTS18DCGR.....	P. 134
UTS610DCG.....	P. 30
UTS612DCG.....	P. 26
UTS614DCG.....	P. 34
UTS618DCG.....	P. 134
UTS68C.....	P. 22
UTS710CCRG.....	P. 30
UTS710CCRR.....	P. 30
UTS710CCRY.....	P. 30
UTS712CCRG.....	P. 26
UTS712CCRR.....	P. 26
UTS712CCRY.....	P. 26
UTS714CCRG.....	P. 34
UTS714CCRR.....	P. 34
UTS714CCRY.....	P. 34

UTS8DCG.....	P. 22
UTS8DCGE.....	P. 22
UTS8DCGR.....	P. 22

### Contacts

82911456K.....	P. 145
82911457NK.....	P. 145
82911458K.....	P. 145
82911459NK.....	P. 145
82911460K.....	P. 145
82911461NK.....	P. 145
82911462K.....	P. 145
82911463NK.....	P. 145
82911464K.....	P. 145
82911465NK.....	P. 145
82911466K.....	P. 145
82911467NK.....	P. 145
82913600A.....	P. 145
82913601A.....	P. 145
82913602A.....	P. 145
82913603A.....	P. 145
82913604A.....	P. 145
82913605A.....	P. 145
82913606A.....	P. 145
82913607A.....	P. 145
82913608A.....	P. 145
82913609A.....	P. 145
RC14M30GE7K.....	P. 146
RC14M30K.....	P. 145
RC14M50GE7K.....	P. 146
RC14M50K.....	P. 145
RC16M23GE7K.....	P. 146
RC16M23K.....	P. 145
RC18W3K.....	P. 145
RC20M12E83K.....	P. 148
RC20M12E84K.....	P. 145
RC20M12E8K.....	P. 145
RC20M12GE7K.....	P. 146
RC20M12K.....	P. 145
RC20M13GE7K.....	P. 146
RC20M13K.....	P. 145
RC20W3K.....	P. 145
RC24M9GE7K.....	P. 146
RC24M9K.....	P. 145
RC24W3K.....	P. 145
RC28M1GE7K.....	P. 146
RC28M1K.....	P. 145
RCDX6016D28.....	P. 182
RCDX6019D28.....	P. 182

RCDX6024D28.....	P. 182
RCDX6026D28.....	P. 182
RCDX602D28.....	P. 181
RCDX6032D28.....	P. 182
RCDX6036D28.....	P. 182
RCDX6052D28.....	P. 182
RCDXK1D28.....	P. 181
RCPOF1000B.....	P. 150
RCW5016K.....	P. 145
RCW50A7K.....	P. 148
RM14M30GE1K.....	P. 146
RM14M30K.....	P. 145
RM14M50GE1K.....	P. 146
RM14M50K.....	P. 148
RM16M23GE1K.....	P. 146
RM16M23K.....	P. 145
RM18W3K.....	P. 145
RM20M12E83K.....	P. 145
RM20M12E8K.....	P. 145
RM20M12GE1k.....	P. 146
RM20M12K.....	P. 145
RM20M13GE1k.....	P. 146
RM20M13K.....	P. 145
RM20W3K.....	P. 145
RM24M9GE1k.....	P. 146
RM24M9K.....	P. 145
RM24W3K.....	P. 145
RM28M1GE1k.....	P. 146
RM28M1K.....	P. 145
RMDX6019D28.....	P. 177
RMDX6024D28.....	P. 176
RMDX6026D28.....	P. 176
RMDX602D28.....	P. 182
RMDX6031D28.....	P. 179
RMDX6032D28.....	P. 182
RMDX6036D28.....	P. 182
RMDX6050D28.....	P. 182
RMDXK10D28.....	P. 178
RMP0F1000.....	P. 150
RMW5016K.....	P. 148
RMW50A7K.....	P. 148
SC14M1TK6.....	P. 145
SC14ML1TK6.....	P. 145
SC16M11TK6.....	P. 145
SC16M1TK6.....	P. 145
SC16ML11TK6.....	P. 145
SC16ML1TK6.....	P. 145
SC20M1TK6.....	P. 145
SC20ML1TK6.....	P. 145
SC20W3TK6.....	P. 145
SC20WL3TK6.....	P. 145

# UTS Series

## Appendices



SC24M1TK6. ....	P. 145	sl 471. ....	P. 180
SC24ML1TK6. ....	P. 145	UH25. ....	P. 155
SC24W3TK6. ....	P. 145	VGE10077A. ....	P. 155
SC24WL3TK6. ....	P. 145	VGE10078A. ....	P. 155
SM14M1TK6. ....	P. 145		
SM14ML1TK6. ....	P. 145		
SM16M11TK6. ....	P. 145		
SM16M1TK6. ....	P. 145		
SM16ML11TK6. ....	P. 145		
SM16ML1TK6. ....	P. 145		
SM20M1TK6. ....	P. 145		
SM20ML1TK6. ....	P. 145		
SM20W3TK6. ....	P. 145		
SM20WL3TK6. ....	P. 145		
SM24M1TK6. ....	P. 145		
SM24ML1TK6. ....	P. 145		
SM24W3TK6. ....	P. 145		
SM24WL3TK6. ....	P. 145		

### Tooling

51060210924. ....	P. 155
51060210936. ....	P. 155
M10S1J. ....	P. 178
M10SG8. ....	P. 179
M317. ....	P. 155
MH860. ....	P. 155
MH86164G. ....	P. 155
MH86186. ....	P. 155
RX2025GE1. ....	P. 155
RX20D44. ....	P.162
S16RCM14. ....	P. 155
S16RCM1450. ....	P. 155
S16RCM16. ....	P. 155
S16SCM20. ....	P. 155
S16SCML1. ....	P. 155
S16SCML11. ....	P. 155
S20RCM. ....	P. 155
S16SCM20. ....	P. 155
S20SCM20. ....	P. 155
S221. ....	P. 180
S23D2. ....	P. 180
S80. ....	P. 179
S82. ....	P. 182
S83. ....	P. 179
S87. ....	P. 182
S88. ....	P. 182
SHANDLES. ....	P. 155
SL105. ....	P. 179
sl 46D2. ....	P. 180

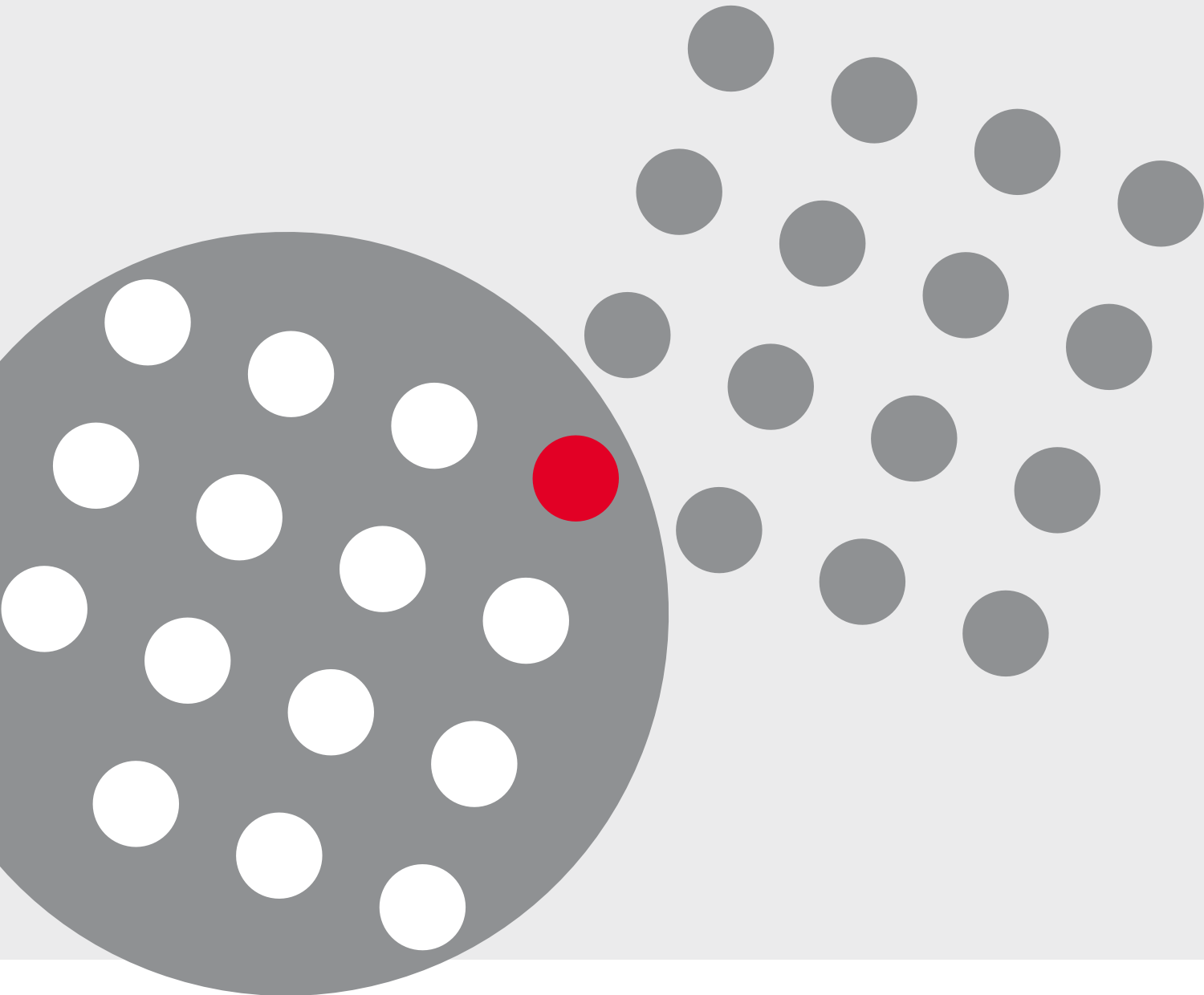

[www.souriau.com](http://www.souriau.com)  
[www.souriau-industrial.com](http://www.souriau-industrial.com)  
[contactindustry@souriau.com](mailto:contactindustry@souriau.com)

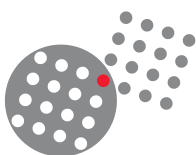

**SOURIAU**

Компания «Океан Электроники» предлагает заключение долгосрочных отношений при поставках импортных электронных компонентов на взаимовыгодных условиях!

Наши преимущества:

- Поставка оригинальных импортных электронных компонентов напрямую с производств Америки, Европы и Азии, а так же с крупнейших складов мира;
- Широкая линейка поставок активных и пассивных импортных электронных компонентов (более 30 млн. наименований);
- Поставка сложных, дефицитных, либо снятых с производства позиций;
- Оперативные сроки поставки под заказ (от 5 рабочих дней);
- Экспресс доставка в любую точку России;
- Помощь Конструкторского Отдела и консультации квалифицированных инженеров;
- Техническая поддержка проекта, помощь в подборе аналогов, поставка прототипов;
- Поставка электронных компонентов под контролем ВП;
- Система менеджмента качества сертифицирована по Международному стандарту ISO 9001;
- При необходимости вся продукция военного и аэрокосмического назначения проходит испытания и сертификацию в лаборатории (по согласованию с заказчиком);
- Поставка специализированных компонентов военного и аэрокосмического уровня качества (Xilinx, Altera, Analog Devices, Intersil, Interpoint, Microsemi, Actel, Aeroflex, Peregrine, VPT, Syfer, Eurofarad, Texas Instruments, MS Kennedy, Miteq, Cobham, E2V, MA-COM, Hittite, Mini-Circuits, General Dynamics и др.);

Компания «Океан Электроники» является официальным дистрибьютором и эксклюзивным представителем в России одного из крупнейших производителей разъемов военного и аэрокосмического назначения «JONHON», а так же официальным дистрибьютором и эксклюзивным представителем в России производителя высокотехнологичных и надежных решений для передачи СВЧ сигналов «FORSTAR».



## JONHON

«JONHON» (основан в 1970 г.)

Разъемы специального, военного и аэрокосмического назначения:

(Применяются в военной, авиационной, аэрокосмической, морской, железнодорожной, горно- и нефтедобывающей отраслях промышленности)

«FORSTAR» (основан в 1998 г.)

ВЧ соединители, коаксиальные кабели, кабельные сборки и микроволновые компоненты:

(Применяются в телекоммуникациях гражданского и специального назначения, в средствах связи, РЛС, а так же военной, авиационной и аэрокосмической отраслях промышленности).



Телефон: 8 (812) 309-75-97 (многоканальный)

Факс: 8 (812) 320-03-32

Электронная почта: [ocean@oceanchips.ru](mailto:ocean@oceanchips.ru)

Web: <http://oceanchips.ru/>

Адрес: 198099, г. Санкт-Петербург, ул. Калинина, д. 2, корп. 4, лит. А