



SY54011R

Low Voltage 1.2V/1.8V CML 1:2 Fanout Buffer, 3.2Gbps, 3.2GHz

General Description

The SY54011R is a fully differential, low voltage 1.2V/1.8V CML 1:2 fanout buffer. It is optimized to provide two identical output copies with less than 15ps of skew and less than 10ps_{pp} total jitter. The SY54011R can process clock signals as fast as 3.2GHz or data patterns up to 3.2Gbps.

The differential input includes Micrel's unique, 3-pin input termination architecture that interfaces to LVPECL, LVDS or CML differential signals, (AC- or DC-coupled from a 2.5V driver) as small as 100mV (200mV_{PP}) without any level-shifting or termination resistor networks in the signal path. For AC-coupled input interface applications, an integrated voltage reference (V_{REF-AC}) is provided to bias the VT pin. The outputs are CML, with extremely fast rise/fall times guaranteed to be less than 95ps.

The SY54011R operates from a 2.5V ±5% core supply and a 1.8V or 1.2V ±5% output supply and is guaranteed over the full industrial temperature range (−40°C to +85°C). The SY54011R is part of Micrel's high-speed, Precision Edge[®] product line.

Datasheets and support documentation can be found on Micrel's web site at: www.micrel.com.



Precision Edge[®]

Features

- 1.2V/1.8V CML 1:2 fanout buffer
- Guaranteed AC performance over temperature and voltage:
 - DC-to- > 3.2Gbps throughput
 - <300ps propagation delay (IN-to-Q)
 - <15ps within-device skew
 - <95ps rise/fall times
- Ultra-low jitter design
 - <1ps_{RMS} random jitter
- High-speed CML outputs
- 2.5V ±5% , 1.8/1.2V ±5% power supply operation
- Industrial temperature range: −40°C to +85°C
- Available in 16-pin (3mm x 3mm) MLF[®] package

Applications

- Data Distribution: OC-48, OC-48+FEC
- SONET clock and data distribution
- Fibre Channel clock and data distribution
- Gigabit Ethernet clock and data distribution

Markets

- Storage
- ATE
- Test and measurement
- Enterprise networking equipment
- High-end servers
- Access
- Metro area network equipment

Functional Block Diagram

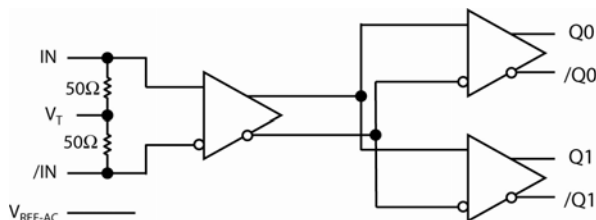

Precision Edge is a registered trademark of Micrel, Inc.
MLF and MicroLeadFrame are registered trademarks of Amkor Technology.

Micrel Inc. • 2180 Fortune Drive • San Jose, CA 95131 • USA • tel +1 (408) 944-0800 • fax + 1 (408) 474-1000 • <http://www.micrel.com>

Ordering Information⁽¹⁾

Part Number	Package Type	Operating Range	Package Marking	Lead Finish
SY54011RMG	MLF-16	Industrial	011R with Pb-Free bar-line indicator	NiPdAu Pb-Free
SY54011RMGTR ⁽²⁾	MLF-16	Industrial	011R with Pb-Free bar-line indicator	NiPdAu Pb-Free

Notes:

- Contact factory for die availability. Dice are guaranteed at $T_A = 25^\circ\text{C}$, DC Electricals only.
- Tape and Reel.

Pin Configuration

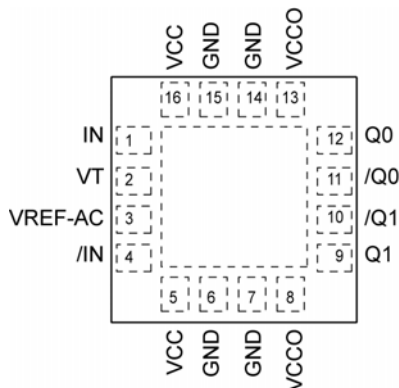

16-Pin MLF[®] (MLF-16)

Pin Description

Pin Number	Pin Name	Pin Function
1, 4	IN, /IN	Differential Input: This input pair is the differential signal input to the device. Input accepts differential signals as small as 100mV (200mV _{PP}). Each input pin internally terminates with 50Ω to the VT pin.
2	VT	Input Termination Center-Tap: Each side of the differential input pair terminates to VT pin. This pin provides a center-tap to a termination network for maximum interface flexibility. See "Interface Applications" subsection.
3	VREF-AC	Reference Voltage: This output biases to $V_{CC} - 1.15\text{V}$. It is used for AC-coupling inputs IN and /IN. Connect VREF-AC directly to the VT pin. Bypass with 0.1μF low ESR capacitor to VCC. Maximum sink/source current is ±0.5mA. See "Input Interface Applications" subsection.
5, 16	VCC	Positive Power Supply: Bypass with 0.1μF//0.01μF low ESR capacitors as close to the VCC pins as possible. Supplies input and core circuitry.
8, 13	VCCO	Output Supply: Bypass with 0.1μF//0.01μF low ESR capacitors as close to the VCCO pins as possible. Supplies the output buffers.
6, 7, 14, 15	GND, Exposed pad	Ground: Exposed pad must be connected to a ground plane that is the same potential as the ground pins.
10, 9 11, 12	/Q1, Q1 /Q0, Q0	CML Differential Output Pairs: Differential buffered copies of the input signal. The output swing is typically 390mV. See "Interface Applications" subsection for termination information.

Absolute Maximum Ratings⁽¹⁾

Supply Voltage (V_{CC})	-0.5V to +3.0V
Supply Voltage (V_{CCO})	-0.5V to +2.7V
$V_{CC} - V_{CCO}$	<1.8V
$V_{CCO} - V_{CC}$	<0.5V
Input Voltage (V_{IN})	-0.5V to V_{CC}
CML Output Voltage (V_{OUT})	0.6V to $V_{CCO}+0.5V$
Current (V_T)	
Source or sink current on V_T pin	$\pm 100mA$
Input Current	
Source or sink current on (IN, /IN)	$\pm 50mA$
Current (V_{REF-AC})	
Source or sink current on V_{REF-AC} ⁽⁴⁾	$\pm 0.5mA$
Maximum operating Junction Temperature	125°C
Lead Temperature (soldering, 20sec.)	260°C
Storage Temperature (T_s)	-65°C to +150°C

Operating Ratings⁽²⁾

Supply Voltage (V_{CC})	2.375V to 2.625V
(V_{CCO})	1.14V to 1.9V
Ambient Temperature (T_A)	-40°C to +85°C
Package Thermal Resistance ⁽³⁾	
MLF [®]	
Still-air (θ_{JA})	75°C/W
Junction-to-board (ψ_{JB})	33°C/W

DC Electrical Characteristics⁽⁵⁾

$T_A = -40^\circ\text{C}$ to $+85^\circ\text{C}$, unless otherwise stated.

Symbol	Parameter	Condition	Min	Typ	Max	Units
V_{CC}	Power Supply Voltage Range	V_{CC}	2.375	2.5	2.625	V
		V_{CCO}	1.14	1.2	1.26	V
		V_{CCO}	1.7	1.8	1.9	V
I_{CC}	Power Supply Current	Max. V_{CC}		15	22	mA
I_{CCO}	Power Supply Current	No Load. V_{CCO}		32	42	mA
R_{IN}	Input Resistance (IN-to- V_T , /IN-to- V_T)		45	50	55	Ω
R_{DIFF_IN}	Differential Input Resistance (IN-to-/IN)		90	100	110	Ω
V_{IH}	Input HIGH Voltage (IN, /IN)	IN, /IN	1.2		V_{CC}	V
V_{IL}	Input LOW Voltage (IN, /IN)	V_{IL} with V_{IH} of 1.2V	0.2		$V_{IH}-0.1$	V
V_{IH}	Input HIGH Voltage (IN, /IN)	IN, /IN	1.14		V_{CC}	V
V_{IL}	Input LOW Voltage (IN, /IN)	V_{IL} with V_{IH} of 1.14V, (1.2V-5%)	0.66		$V_{IH}-0.1$	V
V_{IN}	Input Voltage Swing (IN, /IN)	see Figure 3a	0.1		1.0	V
V_{DIFF_IN}	Differential Input Voltage Swing (IN - /IN)	see Figure 3b	0.2		2.0	V
V_{REF-AC}	Output Reference Voltage		$V_{CC}-1.3$	$V_{CC}-1.15$	$V_{CC}-1.0$	V
V_{T_IN}	Voltage from Input to V_T				1.28	V

Notes:

1. Permanent device damage may occur if absolute maximum ratings are exceeded. This is a stress rating only and functional operation is not implied at conditions other than those detailed in the operational sections of this data sheet. Exposure to absolute maximum ratings conditions for extended periods may affect device reliability.
2. The data sheet limits are not guaranteed if the device is operated beyond the operating ratings.
3. Package thermal resistance assumes exposed pad is soldered (or equivalent) to the device's most negative potential on the PCB. ψ_{JB} and θ_{JA} values are determined for a 4-layer board in still-air number, unless otherwise stated.
4. Due to the limited drive capability, use for input of the same package only.
5. The circuit is designed to meet the DC specifications shown in the above table after thermal equilibrium has been established.

CML Outputs DC Electrical Characteristics⁽⁶⁾

$V_{CCO} = 1.14V$ to $1.26V$ $R_L = 50\Omega$ to V_{CCO} ,

$V_{CCO} = 1.7V$ to $1.9V$, $R_L = 50\Omega$ to V_{CCO} or 100Ω across the outputs,

$V_{CC} = 2.375V$ to $2.625V$. $T_A = -40^\circ C$ to $+85^\circ C$, unless otherwise stated.

Symbol	Parameter	Condition	Min	Typ	Max	Units
V_{OH}	Output HIGH Voltage	$R_L = 50\Omega$ to V_{CCO}	$V_{CCO}-0.020$	$V_{CCO}-0.010$	V_{CCO}	V
V_{OUT}	Output Voltage Swing	See Figure 3a	300	390	475	mV
V_{DIFF_OUT}	Differential Output Voltage Swing	See Figure 3b	600	780	950	mV
R_{OUT}	Output Source Impedance		45	50	55	Ω

Note:

6. The circuit is designed to meet the DC specifications shown in the above table after thermal equilibrium has been established

AC Electrical Characteristics

$V_{CCO} = 1.14V$ to $1.26V$ $R_L = 50\Omega$ to V_{CCO} ,

$V_{CCO} = 1.7V$ to $1.9V$, $R_L = 50\Omega$ to V_{CCO} or 100Ω across the outputs,

$V_{CC} = 2.375V$ to $2.625V$. $T_A = -40^\circ C$ to $+85^\circ C$, unless otherwise stated.

Symbol	Parameter	Condition	Min	Typ	Max	Units
f_{MAX}	Maximum Frequency	NRZ Data	3.2			Gbps
		$V_{OUT} > 200mV$ Clock	3.2			GHz
t_{PD}	Propagation Delay IN-to-Q	Figure 1a	150	205	300	ps
t_{Skew}	Within Device Skew	Note 7		3	15	ps
	Part-to-Part Skew	Note 8			75	ps
t_{Jitter}	Random Jitter				1	ps _{RMS}
t_R t_F	Output Rise/Fall Times (20% to 80%)	At full output swing.	30	60	95	ps
	Duty Cycle	Differential I/O	47		53	%

Notes:

7. Within device skew is measured between two different outputs under identical input transitions.
8. Part-to-part skew is defined for two parts with identical power supply voltages at the same temperature and no skew at the edges at the respective inputs.

Interface Applications

For Input Interface Applications see Figures 4a-f and for CML Output Termination see Figures 5a-d.

CML Output Termination with VCCO 1.2V

For VCCO of 1.2V, Figure 5a, terminate the output with 50Ω-to-1.2V, DC-coupled, not 100Ω differentially across the outputs.

If AC-coupling is used, Figure 5d, terminate into 50Ω-to-1.2V before the coupling capacitor and then connect to a high value resistor to a reference voltage.

Do not AC couple with internally terminated receiver. For example, 50Ω ANY-IN input. AC-coupling will offset the output voltage by 200mV and this offset voltage will be too low for proper driver operation.

Any unused output pair needs to be terminated when VCCO is 1.2V, do not leave floating.

CML Output Termination with VCCO 1.8V

For VCCO of 1.8V, Figure 5a and Figure b, terminate with either 50Ω-to-1.8V or 100Ω differentially across the outputs. AC- or DC-coupling is fine.

Input AC Coupling

The SY54011R input can accept AC coupling from any driver. Tie VT to VREF-AC and bypass with a 0.1μF capacitor as shown in Figures 4c and 4d.

Timing Diagrams

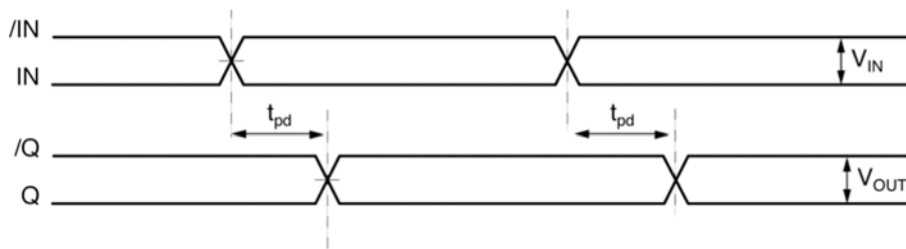
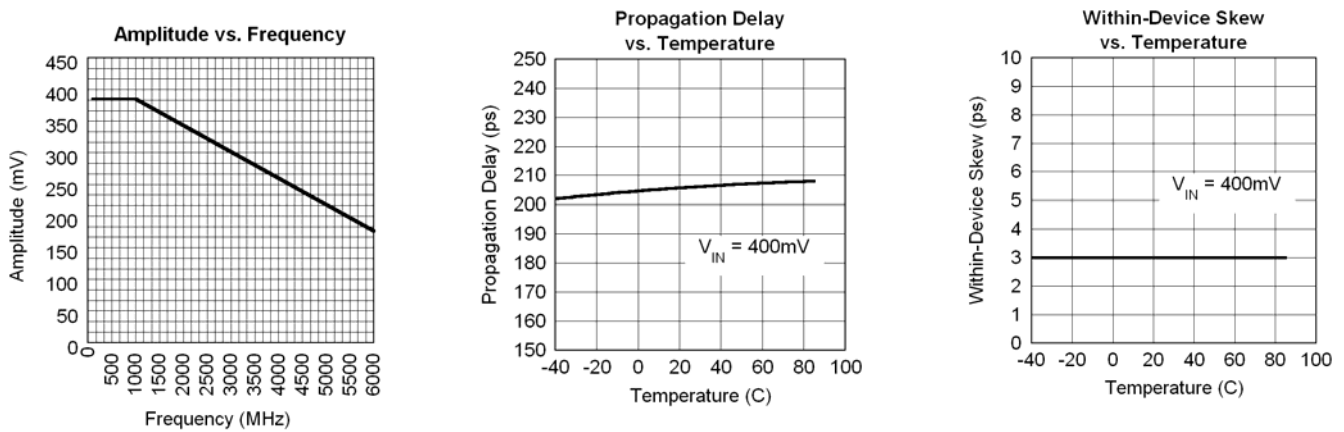

Figure 1a. Propagation Delay

Typical Characteristics

$V_{CC} = 2.5V$, $V_{CCO} = 1.2V$, $GND = 0V$, $V_{IN} = 100mV$; $R_L = 50\Omega$ to $1.2V$; $T_A = 25^\circ C$, unless otherwise stated.



Functional Characteristics

$V_{CC} = 2.5V$, $V_{CCO} = 1.2V$, $GND = 0V$, $V_{IN} = 100mV$; $R_L = 50\Omega$ to $1.2V$, Data Pattern: $2^{23}-1$; $T_A = 25^\circ C$, unless otherwise stated.

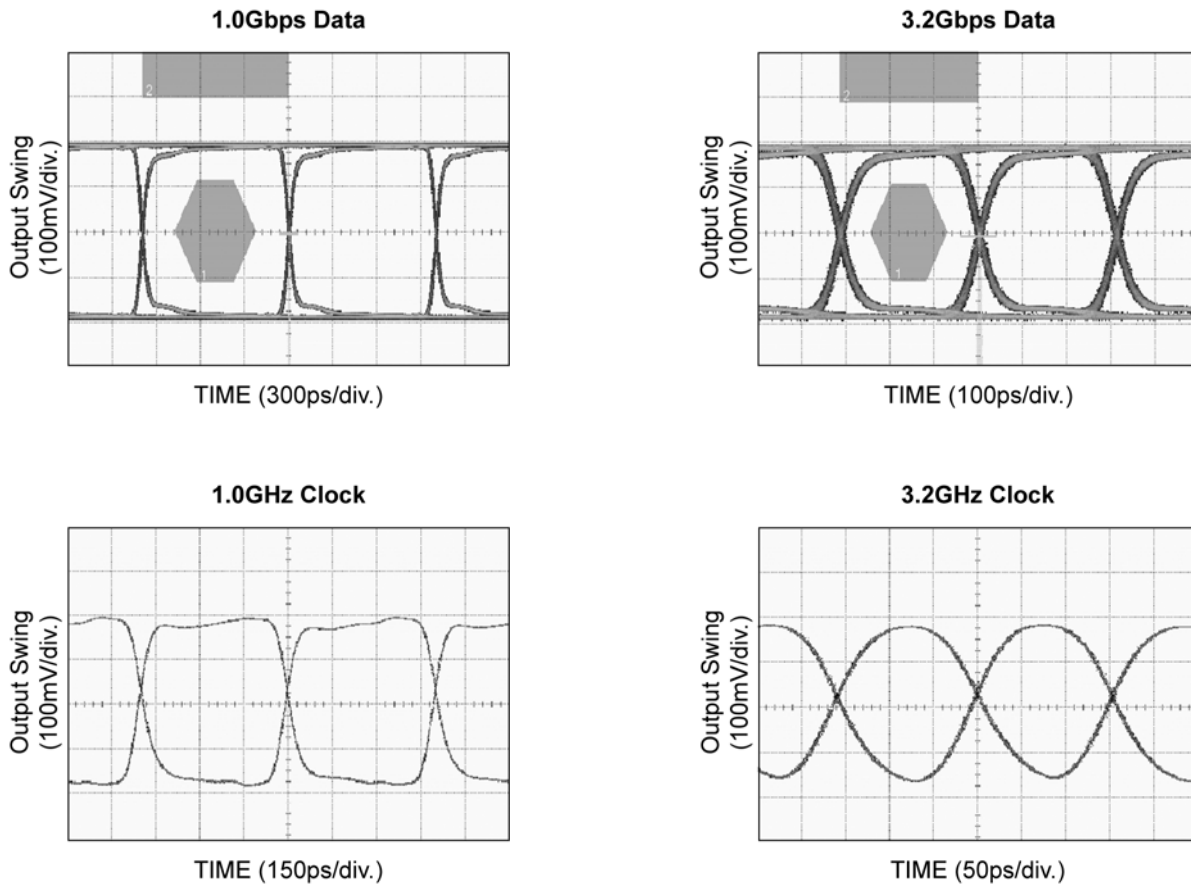

Input and Output Stage

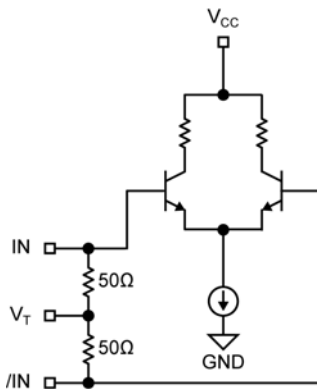

Figure 2a. Simplified Differential Input Buffer

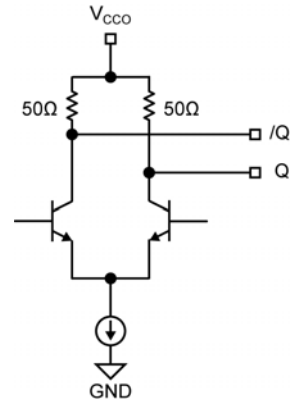

Figure 2b. Simplified CML Output Buffer

Single-Ended and Differential Swings

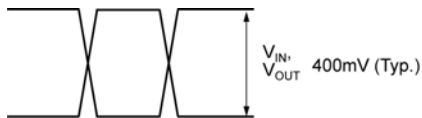

Figure 3a. Single-Ended Swing

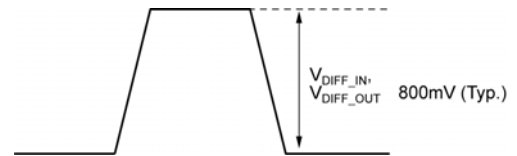

Figure 3b. Differential Swing

Input Interface Applications

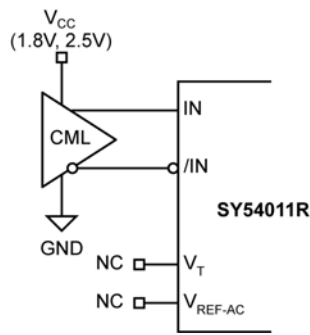

Figure 4a. CML Interface (DC-Coupled, 1.8V, 2.5V)

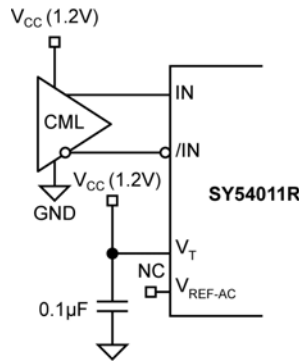

Figure 4b. CML Interface (DC-Coupled, 1.2V)

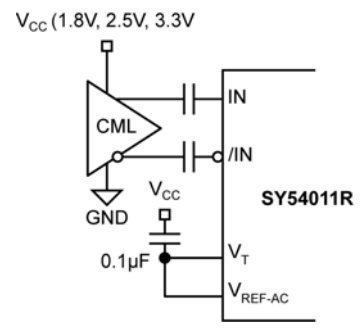

Figure 4c. CML Interface (AC-Coupled)

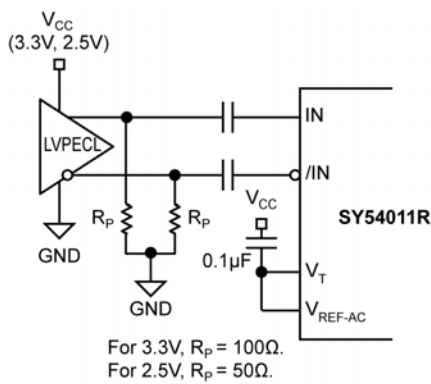

Figure 4d. LVPECL Interface (AC-Coupled)

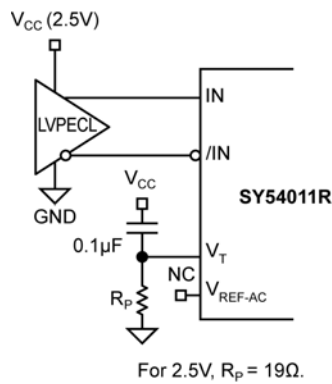

Figure 4e. LVPECL Interface (DC-Coupled)

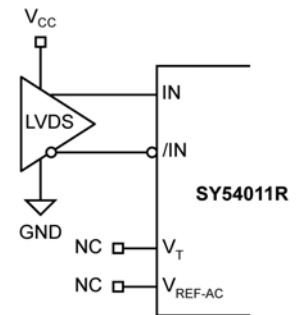

Figure 4f. LVDS Interface

CML Output Termination

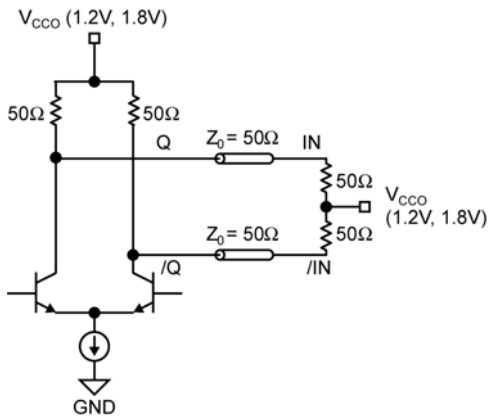

Figure 5a. 1.2V or 1.8V CML DC-Coupled Termination

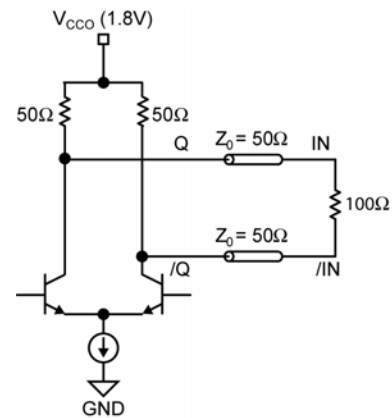

Figure 5b. 1.8V CML DC-Coupled Termination

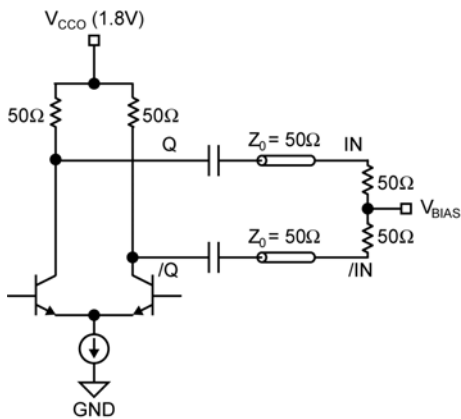

Figure 5c. CML AC-Coupled Termination (VCCO 1.8V only)

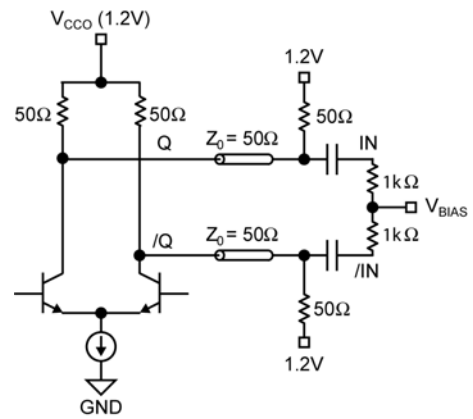
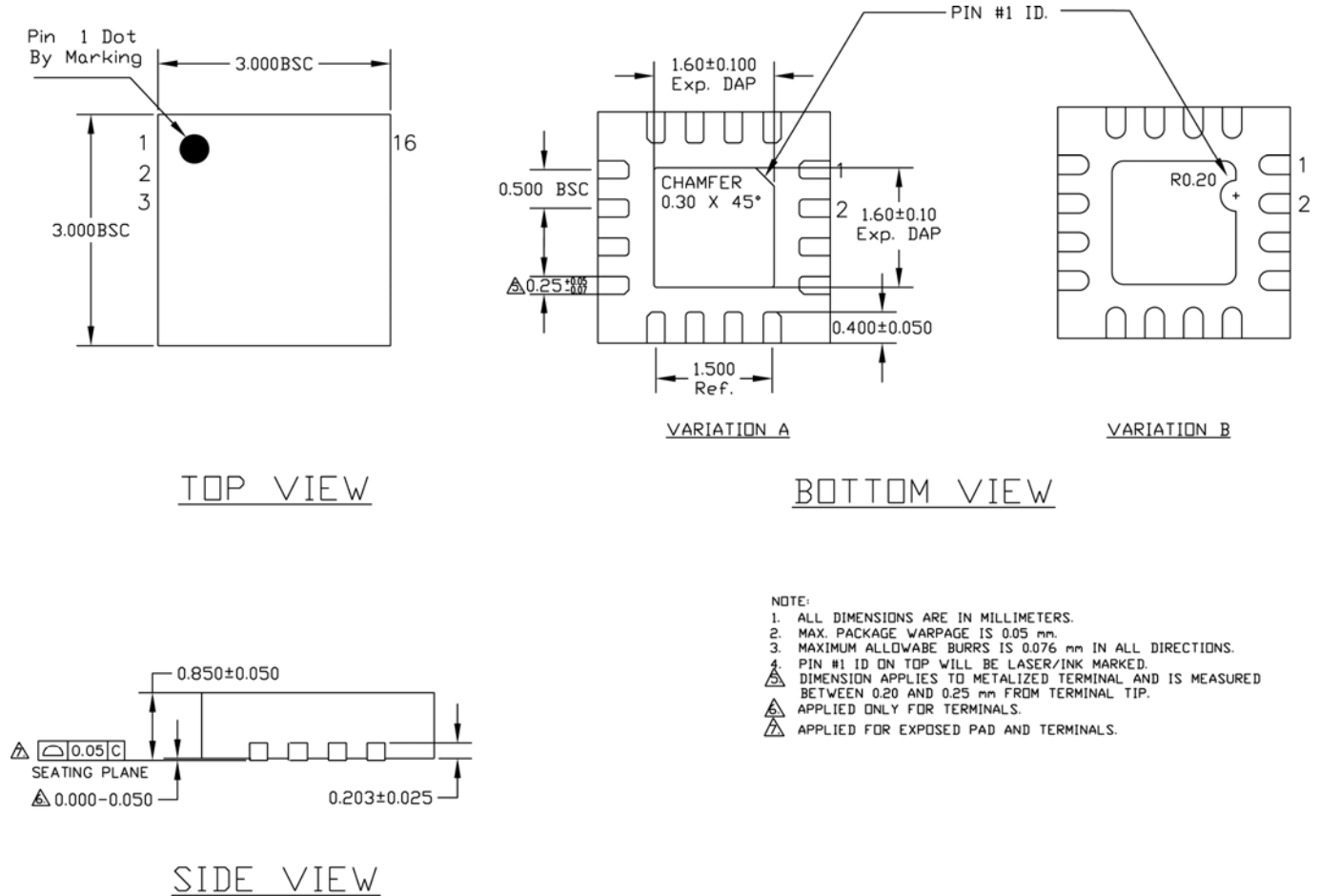

Figure 5d. CML AC-Coupled Termination (VCCO 1.2V only)

Related Product and Support Documents

Part Number	Function	Datasheet Link
HBW Solutions	New Products and Termination Application Notes	http://www.micrel.com/page.do?page=/product-info/as/HBWsolutions.shtml

Package Information



16-Pin MLF[®] (3mm x3mm) (MLF-16)

MICREL, INC. 2180 FORTUNE DRIVE SAN JOSE, CA 95131 USA
 TEL +1 (408) 944-0800 FAX +1 (408) 474-1000 WEB <http://www.micrel.com>

The information furnished by Micrel in this data sheet is believed to be accurate and reliable. However, no responsibility is assumed by Micrel for its use. Micrel reserves the right to change circuitry and specifications at any time without notification to the customer.

Micrel Products are not designed or authorized for use as components in life support appliances, devices or systems where malfunction of a product can reasonably be expected to result in personal injury. Life support devices or systems are devices or systems that (a) are intended for surgical implant into the body or (b) support or sustain life, and whose failure to perform can be reasonably expected to result in a significant injury to the user. A Purchaser's use or sale of Micrel Products for use in life support appliances, devices or systems is a Purchaser's own risk and Purchaser agrees to fully indemnify Micrel for any damages resulting from such use or sale.

© 2008 Micrel, Incorporated.

Компания «Океан Электроники» предлагает заключение долгосрочных отношений при поставках импортных электронных компонентов на взаимовыгодных условиях!

Наши преимущества:

- Поставка оригинальных импортных электронных компонентов напрямую с производств Америки, Европы и Азии, а так же с крупнейших складов мира;
- Широкая линейка поставок активных и пассивных импортных электронных компонентов (более 30 млн. наименований);
- Поставка сложных, дефицитных, либо снятых с производства позиций;
- Оперативные сроки поставки под заказ (от 5 рабочих дней);
- Экспресс доставка в любую точку России;
- Помощь Конструкторского Отдела и консультации квалифицированных инженеров;
- Техническая поддержка проекта, помощь в подборе аналогов, поставка прототипов;
- Поставка электронных компонентов под контролем ВП;
- Система менеджмента качества сертифицирована по Международному стандарту ISO 9001;
- При необходимости вся продукция военного и аэрокосмического назначения проходит испытания и сертификацию в лаборатории (по согласованию с заказчиком);
- Поставка специализированных компонентов военного и аэрокосмического уровня качества (Xilinx, Altera, Analog Devices, Intersil, Interpoint, Microsemi, Actel, Aeroflex, Peregrine, VPT, Syfer, Eurofarad, Texas Instruments, MS Kennedy, Miteq, Cobham, E2V, MA-COM, Hittite, Mini-Circuits, General Dynamics и др.);

Компания «Океан Электроники» является официальным дистрибьютором и эксклюзивным представителем в России одного из крупнейших производителей разъемов военного и аэрокосмического назначения «JONHON», а так же официальным дистрибьютором и эксклюзивным представителем в России производителя высокотехнологичных и надежных решений для передачи СВЧ сигналов «FORSTAR».



JONHON

«JONHON» (основан в 1970 г.)

Разъемы специального, военного и аэрокосмического назначения:

(Применяются в военной, авиационной, аэрокосмической, морской, железнодорожной, горно- и нефтедобывающей отраслях промышленности)

«FORSTAR» (основан в 1998 г.)

ВЧ соединители, коаксиальные кабели,
кабельные сборки и микроволновые компоненты:

(Применяются в телекоммуникациях гражданского и специального назначения, в средствах связи, РЛС, а так же военной, авиационной и аэрокосмической отраслях промышленности).



Телефон: 8 (812) 309-75-97 (многоканальный)

Факс: 8 (812) 320-03-32

Электронная почта: ocean@oceanchips.ru

Web: <http://oceanchips.ru/>

Адрес: 198099, г. Санкт-Петербург, ул. Калинина, д. 2, корп. 4, лит. А