

LTC3723-1, LTC3901,
 LTC4440, and LT1431
 Isolated Full-Bridge Con-
 verter with Synchronous
 Rectification

DESCRIPTION

Demonstration circuit 719 is an Isolated Full-Bridge Converter with Synchronous Rectification featuring the LTC3723-1, LTC3901, LTC4440, and LT1431.

This circuit was designed to demonstrate the high levels of performance, efficiency, and small solution size attainable using these parts in a full-bridge power supply. It operates at 300kHz and produces a regulated 12V, 20A output in a quarter-brick footprint from a typical telecom input voltage range of 42 to 56V. Synchronous rectification helps

to attain efficiency approaching 96%. Isolation voltage is 1500VDC.

Design files for this circuit board are available. Call the LTC factory.

LT, LTC, LTM, LT, Burst Mode, OPTI-LOOP, Over-The-Top and PolyPhase are registered trademarks of Linear Technology Corporation. Adaptive Power, C-Load, DirectSense, Easy Drive, FilterCAD, Hot Swap, LinearView, μ Module, Micropower SwitcherCAD, Multimode Dimming, No Latency $\Delta\Sigma$, No Latency Delta-Sigma, No R_{SENSE} , Operational Filter, PanelProtect, PowerPath, PowerSOT, SmartStart, SoftSpan, Stage Shedding, SwitcherCAD, ThinSOT, UltraFast and VLDO are trademarks of Linear Technology Corporation. Other product names may be trademarks of the companies that manufacture the products.

PERFORMANCE SUMMARY Specifications are at TA = 25°C

SYMBOL	PARAMETER	CONDITIONS	MIN	TYP	MAX	UNITS
V_{IN}	Input Supply Range		42		56	V
V_{OUT}	Output Voltage			12		V
I_{OUT}	Output Current Range	$V_{IN} = 42 - 56V$	0		20	A
F_{SW}	Switching (Clock) Frequency			300		kHz
$V_{OUT\ P-P}$	Output Ripple	$V_{IN} = 48V, I_{OUT} = 20A$ (20MHz BW)		240		mV _{P-P}
I_{REG}	Output Regulation	Line and Load (42-56V, 0-20A)		± 0.2		%
P_{OUT}/P_{IN}	Efficiency (see Figures 2 and 3)	$V_{IN} = 48V, I_{OUT} = 20A$		95		%

OPERATING PRINCIPLES

The LTC3723-1 Synchronous Push-Pull PWM Controller is used on the primary and works together with the LTC3901 Secondary Side Synchronous Driver to provide a synchronous rectified output. When an input voltage is applied, the LTC3723-1 begins a controlled soft-start of the output voltage. As this voltage begins to rise, the LT1431 Programmable Reference is quickly pow-

ered up via the output voltage. The LT1431 provides feedback via optocoupler ISO1 to set the output voltage at 12V. The LTC4440 High Voltage Gate Driver is used to level shift the high-side primary MOSFETs' gate signals. The LTC3723-1 provides precise control of gate signals to the primary MOSFETs, and to the secondary MOSFETs via T2 and U1 (LTC3901). The LTC3901 includes

LTC3723-1, LTC3901, LTC4440, AND LT1431

a timer and current sense to limit reverse inductor current.

For large values of input inductance, a 100V, 47 μ F electrolytic capacitor can be added across the in-

put terminals to damp the input filter and provide adequate stability. See Linear Technology Application Note AN19 for a discussion on input filter stability analysis. A recommended part is the Sanyo 100MV47AX.

QUICK START PROCEDURE

Demonstration circuit 719 is easy to set up to evaluate the performance of the LTC3723-1, LTC3901, LTC4440, and LT1431. Refer to Figure 1 for proper measurement equipment setup and follow the procedure below:

NOTE. When measuring the output voltage ripple, care must be taken to avoid a long ground lead on the oscilloscope probe. Measure the output voltage ripple by touching the probe tip and ground ring directly across the last ceramic output capacitor as shown in Figure 1.

1. Set an input power supply that is capable of 42V to 56V to 48V. Then turn off the supply.
2. Direct an airflow of 200lfm across the unit for sustained operation at full load.
3. With power off, connect the supply to the input terminals +Vin and –Vin.
 - a. Input voltages lower than 42V can keep the converter from turning on due to the undervoltage lockout feature of the LTC3723-1.
 - b. If efficiency measurements are desired, an ammeter capable of measuring 10Adc or a resistor shunt can be put in series with the input supply in order to measure the DC719A's input current.
 - c. A voltmeter with a capability of measuring at least 56V can be placed across the input terminals in order to get an accurate input voltage measurement.
4. Turn on the power at the input.

NOTE. Make sure that the input voltage never exceeds 56V.

5. Check for the proper output voltage of 12V. Turn off the power at the input.
6. Once the proper output voltages are established, connect a variable load capable of sinking 20A at 12V to the output terminals +Vout and –Vout. Set the current for 0A.
 - a. If efficiency measurements are desired, an ammeter or a resistor shunt that is capable of handling 20Adc can be put in series with the output load in order to measure the DC719A's output current.
 - b. A voltmeter with a capability of measuring at least 12V can be placed across the output terminals in order to get an accurate output voltage measurement.
7. Turn on the power at the input.

NOTE. If there is no output, temporarily disconnect the load to make sure that the load is not set too high.

8. Once the proper output voltage is again established, adjust the load within the operating range and observe the output voltage regulation, ripple voltage, efficiency and other desired parameters.

LTC3723-1, LTC3901, LTC4440, AND LT1431

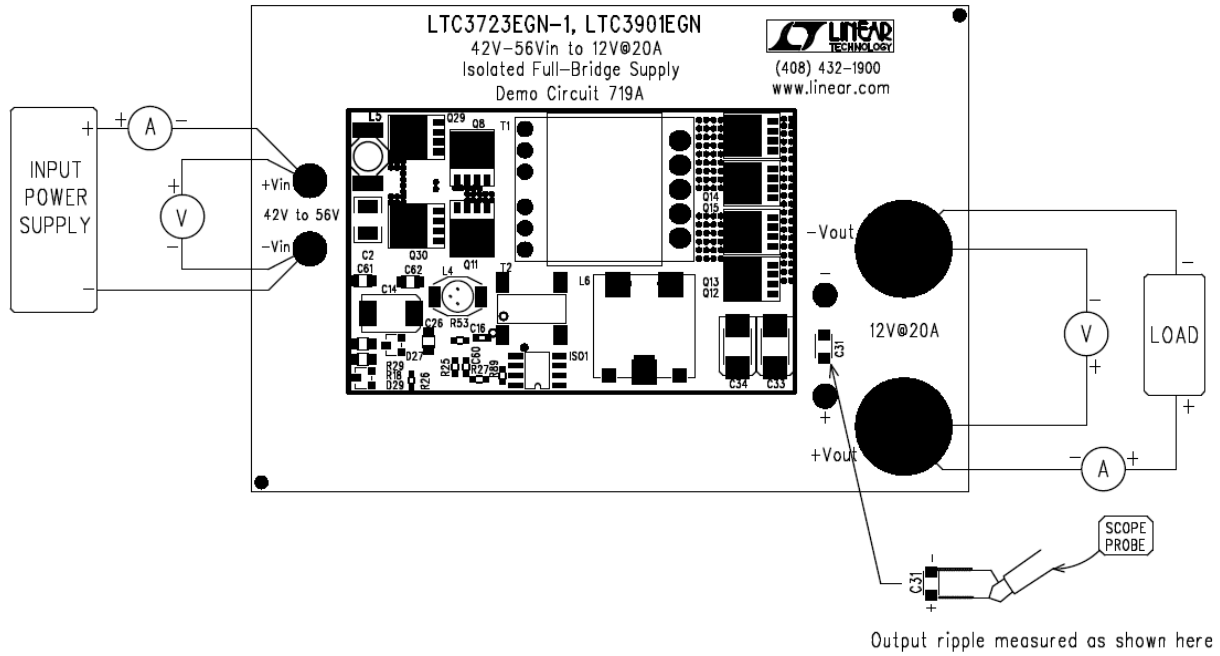

Figure 1. Proper Measurement Equipment Setup

LTC3723-1, LTC3901, LTC4440, AND LT1431

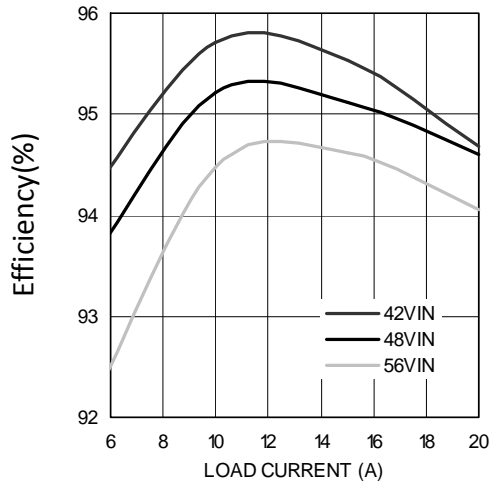

Figure 2. Efficiency with Demo Board Inductor

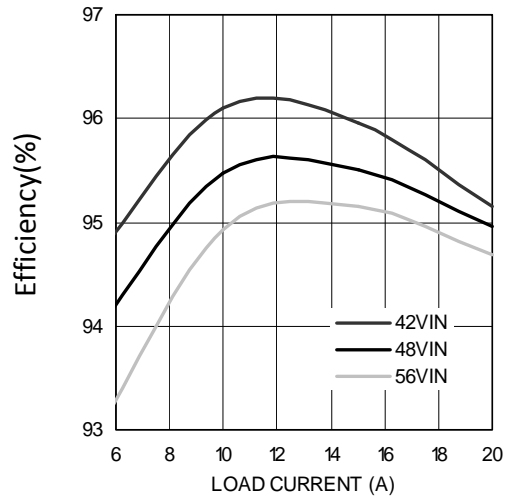

Figure 3. Efficiency with Pulse 1294.132 OR Inductor

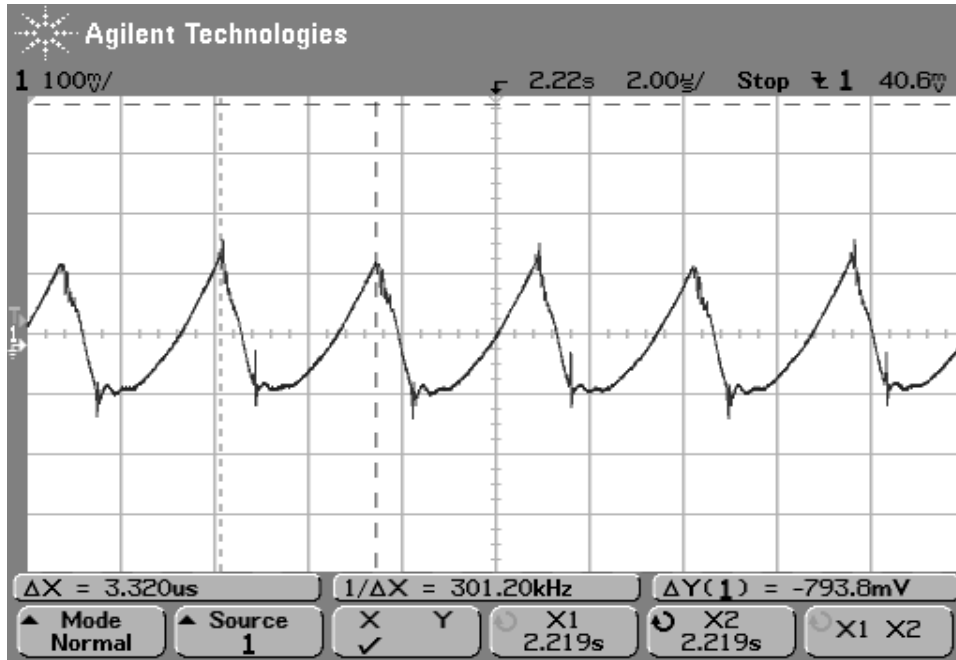
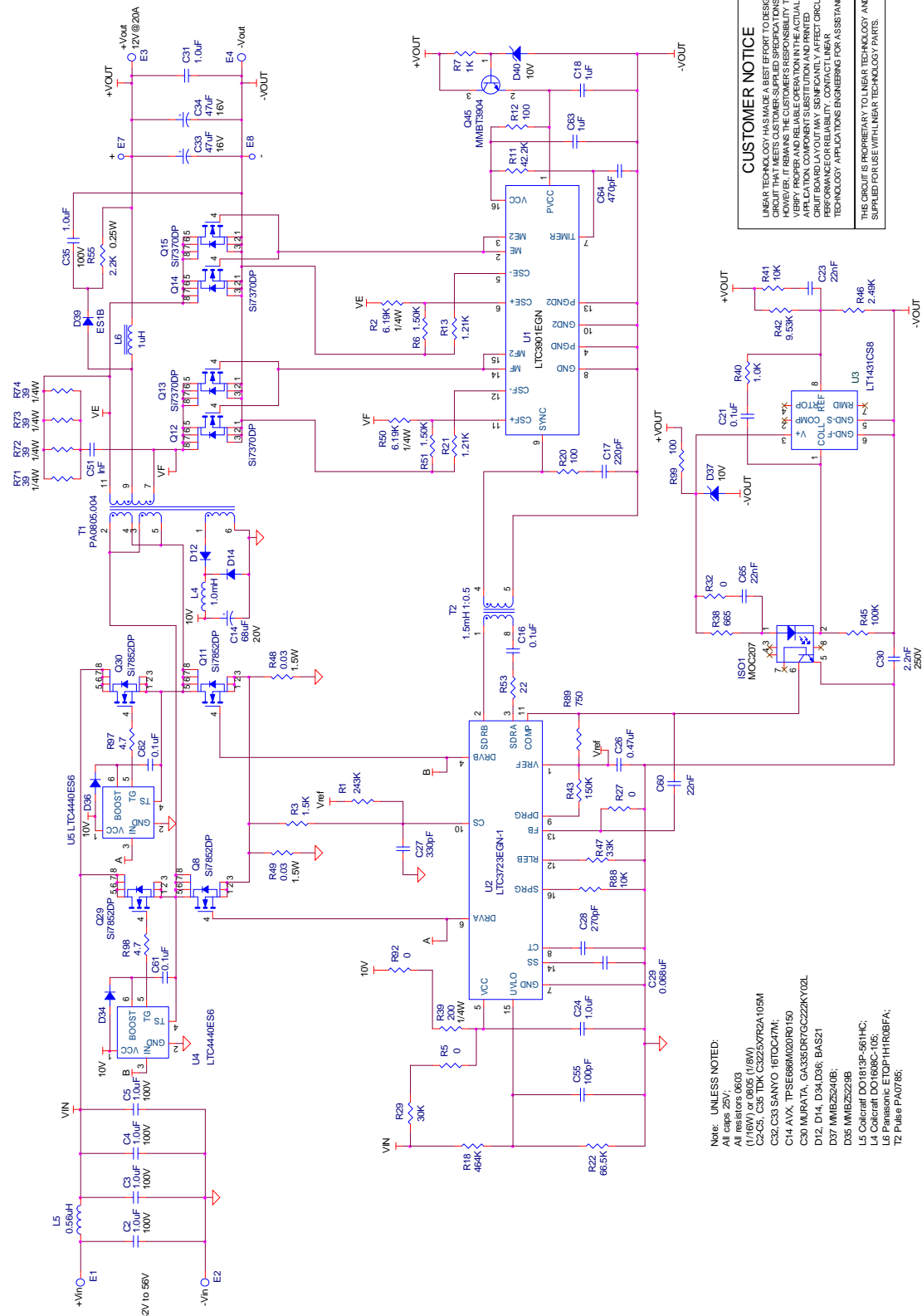

Figure 4. Output Ripple

LTC3723-1, LTC3901, LTC4440, AND LT1431



CUSTOMER NOTICE
 LINEAR TECHNOLOGY HAS MADE A BEST EFFORT TO DESIGN A CIRCUIT THAT MEETS CUSTOMER-SUPPLIED SPECIFICATIONS. CUSTOMERS ARE RESPONSIBLE FOR VERIFYING THE ACTUAL VERIFICATION OF THE ACTUAL APPLICATION, COMPONENT SUBSTITUTION AND PRINTED CIRCUIT BOARD LAYOUT MAY SIGNIFICANTLY AFFECT CIRCUIT PERFORMANCE. CONTACT YOUR LOCAL SALES OFFICE OR TECHNICAL SUPPORT FOR ASSISTANCE.

THIS CIRCUIT IS PROPRIETARY TO LINEAR TECHNOLOGY AND SUPPLIED FOR USE WITH LINEAR TECHNOLOGY PARTS.

Note: UNLESS NOTED:
 All caps 25V.
 All resistors 0603 (1/16W) or 0805 (1/8W).
 C2-C6, C35 10K C52-C55 0.2A-108M
 C14 AVX, TPS5E86M020R150
 C30 MURATA, GA335DR7G222KY02L
 D12, D14, D34-D36: BAS21
 D37 MMBZ5240B;
 D35 MMBZ5229B
 L5 Coilcraft DO1813P-561HC;
 L4 Coilcraft DO1608C-105;
 L6 Panasonic ETQP1HR0BFA;
 T2 Pulse PA0785;

Figure 5. Simplified Circuit Schematic

LTC3723-1, LTC3901, LTC4440, AND LT1431

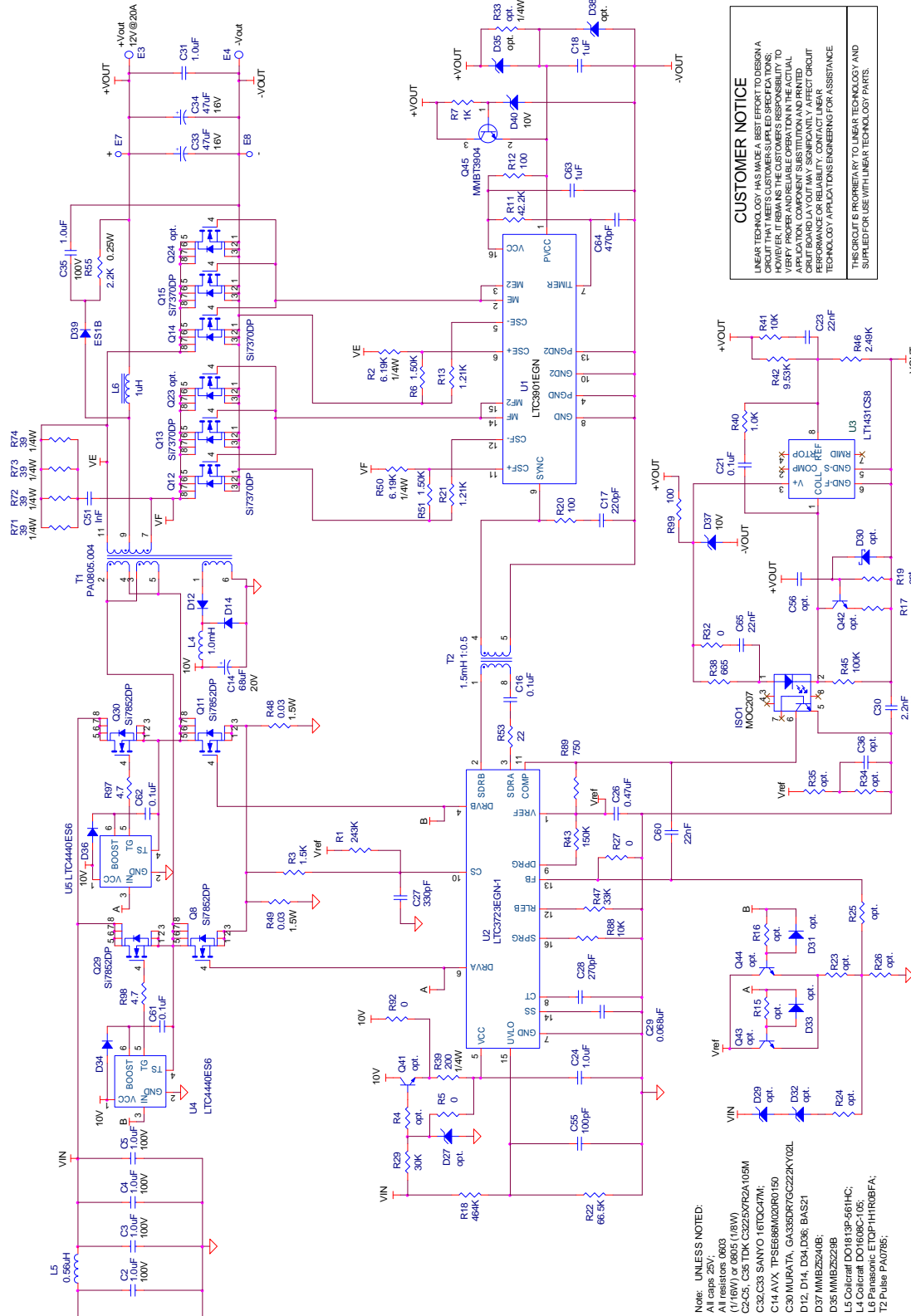

Figure 6. Complete Board Schematic

Компания «Океан Электроники» предлагает заключение долгосрочных отношений при поставках импортных электронных компонентов на взаимовыгодных условиях!

Наши преимущества:

- Поставка оригинальных импортных электронных компонентов напрямую с производств Америки, Европы и Азии, а так же с крупнейших складов мира;
- Широкая линейка поставок активных и пассивных импортных электронных компонентов (более 30 млн. наименований);
- Поставка сложных, дефицитных, либо снятых с производства позиций;
- Оперативные сроки поставки под заказ (от 5 рабочих дней);
- Экспресс доставка в любую точку России;
- Помощь Конструкторского Отдела и консультации квалифицированных инженеров;
- Техническая поддержка проекта, помощь в подборе аналогов, поставка прототипов;
- Поставка электронных компонентов под контролем ВП;
- Система менеджмента качества сертифицирована по Международному стандарту ISO 9001;
- При необходимости вся продукция военного и аэрокосмического назначения проходит испытания и сертификацию в лаборатории (по согласованию с заказчиком);
- Поставка специализированных компонентов военного и аэрокосмического уровня качества (Xilinx, Altera, Analog Devices, Intersil, Interpoint, Microsemi, Actel, Aeroflex, Peregrine, VPT, Syfer, Eurofarad, Texas Instruments, MS Kennedy, Miteq, Cobham, E2V, MA-COM, Hittite, Mini-Circuits, General Dynamics и др.);

Компания «Океан Электроники» является официальным дистрибьютором и эксклюзивным представителем в России одного из крупнейших производителей разъемов военного и аэрокосмического назначения «JONHON», а так же официальным дистрибьютором и эксклюзивным представителем в России производителя высокотехнологичных и надежных решений для передачи СВЧ сигналов «FORSTAR».



JONHON

«JONHON» (основан в 1970 г.)

Разъемы специального, военного и аэрокосмического назначения:

(Применяются в военной, авиационной, аэрокосмической, морской, железнодорожной, горно- и нефтедобывающей отраслях промышленности)

«FORSTAR» (основан в 1998 г.)

ВЧ соединители, коаксиальные кабели, кабельные сборки и микроволновые компоненты:

(Применяются в телекоммуникациях гражданского и специального назначения, в средствах связи, РЛС, а так же военной, авиационной и аэрокосмической отраслях промышленности).



Телефон: 8 (812) 309-75-97 (многоканальный)

Факс: 8 (812) 320-03-32

Электронная почта: ocean@oceanchips.ru

Web: <http://oceanchips.ru/>

Адрес: 198099, г. Санкт-Петербург, ул. Калинина, д. 2, корп. 4, лит. А