

## USB 2.0 High-Speed and Audio Switches with Negative Signal Capability

### Features

- Single +2.7V to +4.4V Supply Voltage
- Low 50 $\mu$ A Supply Current
- -3dB Bandwidth: 1500MHz (typ)
- Low 2.5 $\Omega$ (typ)On-Resistance
- THD+N: 0.02%
- Shorting D+/R and D-/L to Vbus will not cause leakage when  $V_{DD} = 0$
- Internal Shunt Resistors for Click-and-Pop Reduction
- VBUS Detection for Automatic Switch Path Selection
- Packaging (Pb-free & Green available):  
= 10-pin contact UQFN, 1.4 x 1.8, (ZM10)

### Description

The PI3USB223 combines AC coupled audio signals and USB2.0 HS (480Mbps) on the same pins. This enables users to use a single connector to drive either a USB end point or an audio end point.

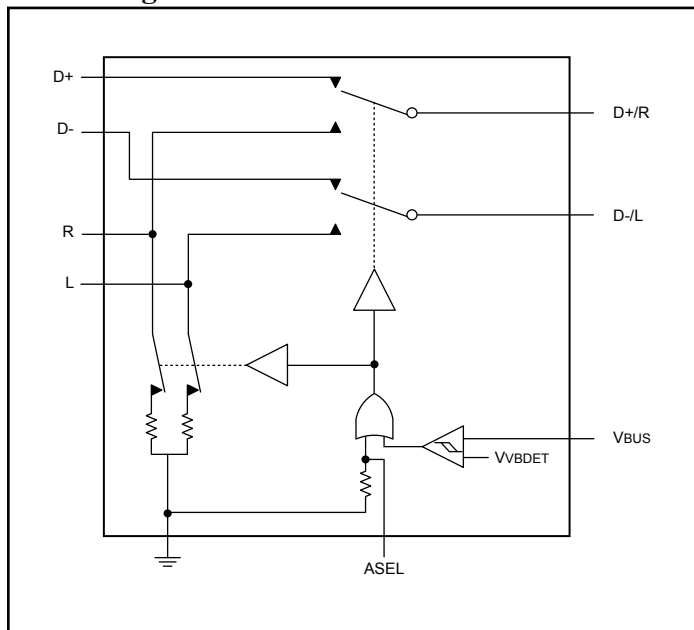
PI3USB223 incorporates gate pump technology required to maintain low Ron for ideal audio THD while reducing the capacitance affect of high speed USB signals. The device also incorporates a substrate pump technology which allows -2V signals to pass through the switch without causing any leakage.

The PI3USB223 features protection on D+/R and D-/L to ensure no damage will happen to the IC if these pins are shorted accidentally to Vbus as well as ensuring there is no leakage when  $V_{DD}$  is on or off. Also, it includes VBUS detection (VB) to automatically switch to the USB signal path upon detection of a valid VBUS signal. It also features internal shunt resistors on the audio path to reduce clicks and pops heard during output. The device is available in a space-saving 10-pin, 1.4mm x 1.8mm UQFN package, and operate over the -40 $^{\circ}$ C to +85 $^{\circ}$ C temperature range.

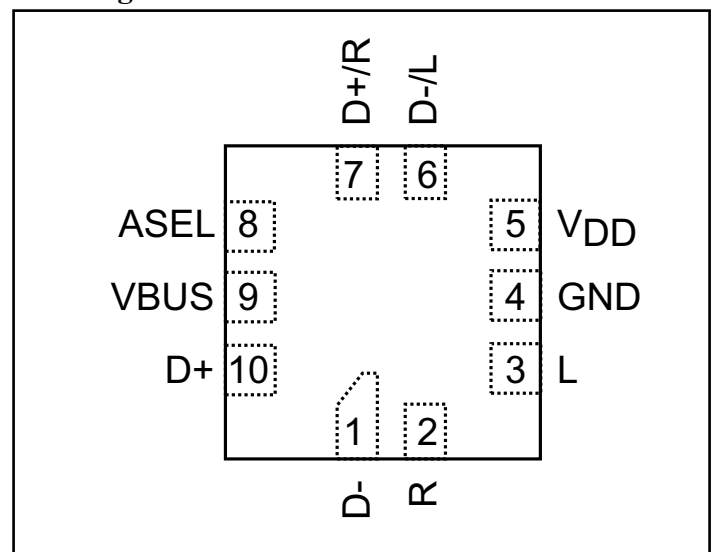
### Truth Table

ASEL	V <sub>DD</sub>	VBUS	L/R	D+/D-	L/R Shunt
X	L	L	OFF	OFF	OFF
X	H	L	OFF	OFF	ON
X	L	H	OFF	OFF	OFF
L	H	H	OFF	ON	ON
H	H	H	ON	OFF	OFF

### Block Diagram



### Pin Diagram



### Pin Description

Pin#	Name	Function
1	D-	USB D- from system side
2	R	Audio Input (Right)
3	L	Audio Input (Left)
4	GND	Ground
5	V <sub>DD</sub>	Positive Supply Voltage Input. Bypass V <sub>DD</sub> to GND with a 0.1μF capacitor as close to the device as possible.
6	D-/L	Common Terminal for D- or Left Audio
7	D+/R	Common Terminal for D+ or Right Audio
8	ASEL	Switch SEL to override VBUS detection when VBUS and V <sub>DD</sub> are both high. If ASEL is HIGH, then audio path will be on If ASEL is LOW then USB path will be on ASEL has an internal 3M-ohm pull-down
9	VBUS	If ASEL is tied LOW, then VBUS detection can be used for auto switching. If ASEL is LOW VBUS = HIGH means USB path is active
10	D+	USB D+ from system side

### Maximum Ratings

(Above which useful life may be impaired. For user guidelines, not tested.)

(Voltages referenced to GND.)	
V <sub>DD</sub> , ASEL .....	-0.3V to +5.0V
V <sub>BUS</sub> .....	-0.3V to +5.5V
V <sub>(R/D+)</sub> and V <sub>(L/D-)</sub> <sup>(1)</sup> .....	-2.0V to +5.0V
V <sub>(R/D+)</sub> and V <sub>(L/D-)</sub> <sup>(2)</sup> .....	-0.3V to +5.0V
V <sub>R</sub> and V <sub>L</sub> .....	-2.0V to (V <sub>DD</sub> + 0.3V)
V <sub>D+</sub> and V <sub>D-</sub> .....	-0.3V to (V <sub>DD</sub> + 0.3V)
Continuous Current into Any Terminal.....	±100mA
Operating Temperature Range .....	-40°C to +85°C
Storage Temperature Range .....	-65°C to +150°C

**Notes:**

1. If Audio path is enabled
2. If USB path is enabled

Stresses greater than those listed under MAXIMUM RATINGS may cause permanent damage to the device. This is a stress rating only and functional operation of the device at these or any other conditions above those indicated in the operational sections of this specification is not implied. Exposure to absolute maximum rating conditions for extended periods may affect reliability.

### DC Electrical Characteristics

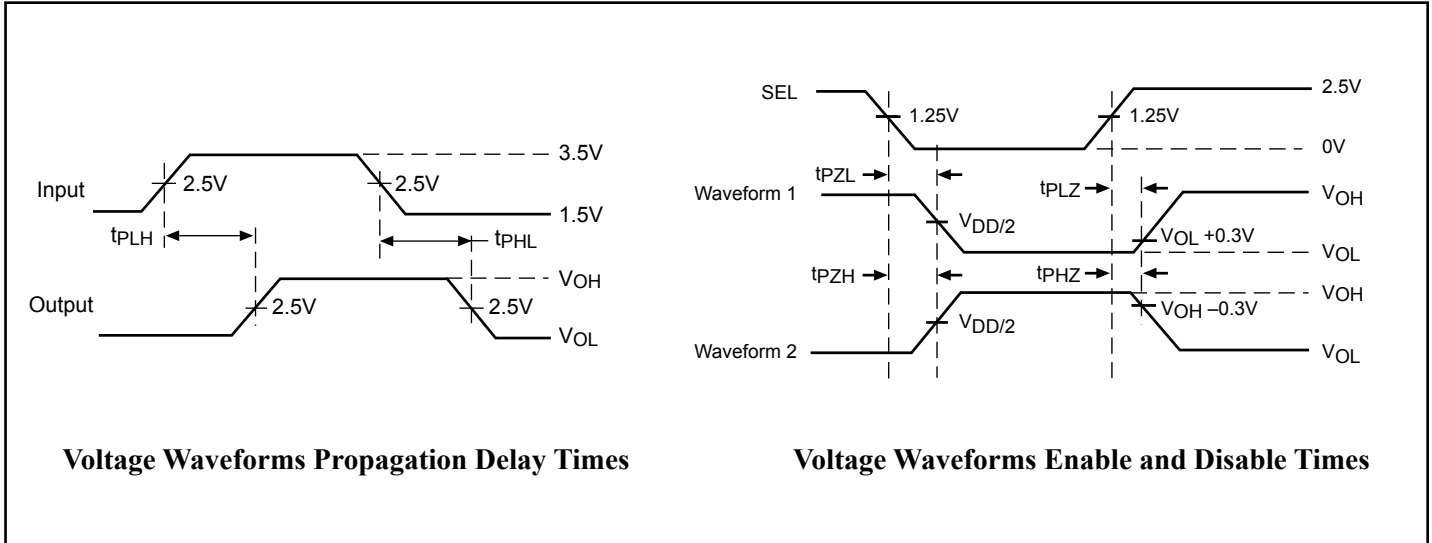
(V<sub>DD</sub> = 2.7V to 4.4V, T<sub>A</sub> = -40°C to +85°C, unless otherwise noted. Typical values are at V<sub>DD</sub> = 3.0V to 3.6V, T<sub>A</sub> = 25°C)

Parameter	Symbol	Test Conditions		Min.	Typ.	Max.	Units
Operating Power-supply range	V <sub>DD</sub>			2.7	-	4.4	V
Supply Current	I <sub>CC</sub>	V <sub>DD</sub> = 3.3V	ASEL = VBUS = 0V	-	-	50	µA
Power-supply Rejection Ratio	PSRR		f = 10kHz, V <sub>DD</sub> = 3.0 ±0.3V, R <sub>D+/R</sub> = 50Ω	-	60	-	dB
Analog Signal Range	V <sub>D+/-</sub>			0		V <sub>DD</sub>	V
	V <sub>R/L</sub>			-2		V <sub>DD</sub>	
R/L On-Resistance	R <sub>ON(R/L)</sub>		V <sub>DD</sub> = 3.0V, V <sub>R/L</sub> = -1.5V, +1.5V, I <sub>D+/R</sub> and D-/L = 10mA		2	5	Ω
D+/D- On-Resistance	R <sub>ON(D+/-)</sub>		V <sub>DD</sub> = 3.0V, V <sub>D+/-</sub> = -0.4V to 0.6V, I <sub>D+/R</sub> and D-/L = 10mA		3.5	6	
			V <sub>DD</sub> = 3.0V, V <sub>D+/R</sub> and D-/L = 1.0V to 3.0V, I <sub>D+/R</sub> and D-/L = 10mA			12	
R/L On-Resistance Match between Channels	ΔR <sub>ON(R/L)</sub>		V <sub>DD</sub> = 3.0V, V <sub>R/L</sub> = 0V, I <sub>D+/R</sub> and D-/L = 10mA			0.2	
D+/- On-Resistance Match between Channels	ΔR <sub>ON(D+/D-)</sub>		V <sub>DD</sub> = 3.0V, V <sub>D+/-</sub> = 0V, I <sub>D+/R</sub> and D-/L = 10mA			0.2	
R/L On-Resistance Flatness	R <sub>FLAT(R/L)</sub>		V <sub>DD</sub> = 3.0V, I <sub>D+/R</sub> and D-/L = 10mA, V <sub>R/L</sub> = -1.5V to +1.5V		0.3	0.5	
D+/D- On-Resistance Flatness	R <sub>FLAT(D+/-)</sub>		V <sub>DD</sub> = 3.0V, I <sub>D+/R</sub> and D-/L = 10mA, V <sub>D+/-</sub> = -0.4V to 0.6V		0.25	0.5	
Shunt Switch Resistance	R <sub>SH</sub>		Voltage on R or L = V <sub>DD</sub>		25		kΩ
D+/- Off-Leakage Current	I <sub>D+/(OFF)</sub>		V <sub>DD</sub> = 3.0V, V <sub>D+/-</sub> = 5V, V <sub>D+/R</sub> and D-/L = -1.5V, +2.5V	-1		1	µA
R/L Off-Leakage Current	I <sub>R/L(OFF)</sub>		V <sub>DD</sub> = 3.0V, V <sub>R/L</sub> = 0V, V <sub>D+/R</sub> and D-/L = 0V, +2.5V	-1		1	

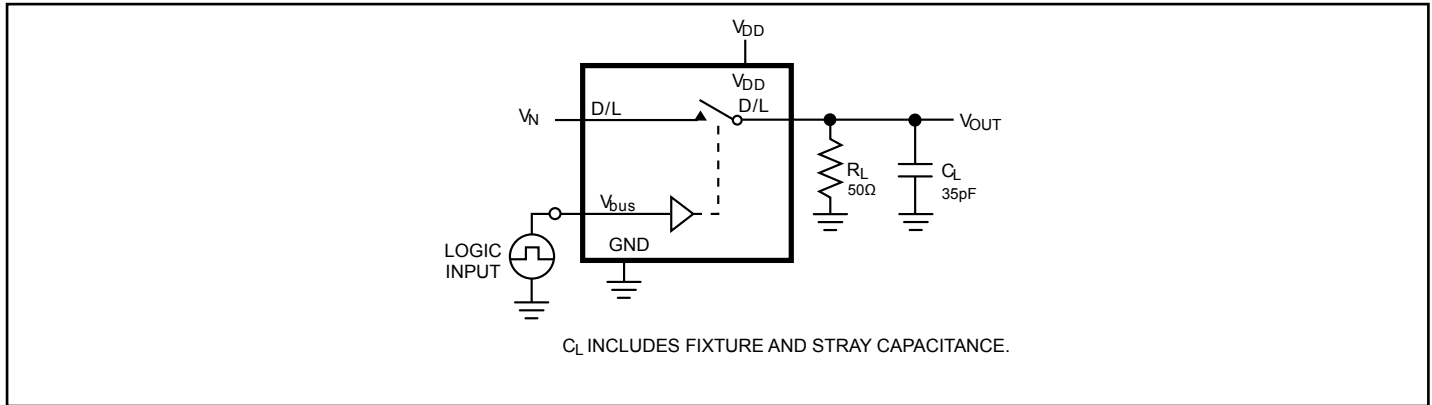
Parameter	Symbol	Test Conditions	Min.	Typ.	Max.	Units
D+/R and D-/L Off-Leakage Current	I <sub>D+/R and D-/L(OFF)</sub>	V <sub>DD</sub> = 3.0V, V <sub>D+/R and D-/L</sub> = 3.6V, V <sub>D+/-</sub> = V <sub>R/L</sub> = 0V			5	μA
		V <sub>DD</sub> = 3.3V, V <sub>D+/R and D-/L</sub> = 0V, V <sub>D+/-</sub> = V <sub>R/L</sub> = 0V			5	
		V <sub>DD</sub> = 0V, V <sub>D+/R or D-/L</sub> = 5.0V, V <sub>D+/-</sub> = V <sub>R/L</sub> = 0V			5	
System Bus Input Voltage	V <sub>BUS</sub>		0		5.5	V
D+/R and D-/L On-Leakage Current	I <sub>D+/R and D-/L(ON)</sub>	USB Mode V <sub>DD</sub> = 3.0V, V <sub>R/L</sub> = 0V, 2.5V, unconnected, V <sub>D+/R and D-/L</sub> = 0V, 2.5V	-200		200	nA
		Audio Mode V <sub>DD</sub> = 3.0V, V <sub>D+/-</sub> = 0V, 2.5V, unconnected, V <sub>D+/R and D-/L</sub> = -1.5V, +2.5V	-200		200	
Turn-On Time	t <sub>ON</sub>	R/L to D-/L or D+/R, V <sub>DD</sub> = 3.0V, Fig. 2	V <sub>R/L</sub> = 1.5V, Z <sub>L</sub> = 50-ohm//35pF, ASEL = V <sub>DD</sub> , V <sub>BUS</sub> = 5.0V to 0V		12	60
		D+/- to D-/L or D+/R, V <sub>DD</sub> = 3.0V, Fig. 2	V <sub>R/L</sub> = 1.5V, Z <sub>L</sub> = 50-ohm//35pF, V <sub>VBUS</sub> = 5.0V, ASEL = 0V to V <sub>DD</sub>		12	60
Turn-Off Time	t <sub>OFF</sub>	R/L to D-/L or D+/R, V <sub>DD</sub> = 3.0V, Fig. 2	V <sub>R/L</sub> = 1.5V, Z <sub>L</sub> = 50-ohm//35pF, ASEL = V <sub>DD</sub> , V <sub>BUS</sub> = 5.0V to 0V		1.4	5
		D+/- to D-/L or D+/R, V <sub>DD</sub> = 3.0V, Fig. 2	V <sub>R/L</sub> = 1.5V, Z <sub>L</sub> = 50-ohm//35pF, V <sub>VBUS</sub> = 5.0V, ASEL = 0V to V <sub>DD</sub>		0.7	5
Break-Before-Make Time Delay	t <sub>D</sub>	Z <sub>L</sub> = 50Ω // 35pF		13.5		
Output Skew Same Switch	t <sub>SK(P)</sub>	Figure 3		10		ps
Output Skew Between Switches	t <sub>SK(O)</sub>	Figure 3		10		
R/L Off-Capacitance	C <sub>R/L(OFF)</sub>	V <sub>D+/R and D-/L</sub> = 0.5V <sub>PP</sub> , DC Bias = 0V, f = 1MHz,		3		pF
D+/- Off-Capacitance	C <sub>D+/(OFF)</sub>	V <sub>D+/R and D-/L</sub> = 1.5V <sub>PP</sub> , DC Bias = 0V, f = 240MHz,		2.5		
On-Capacitance	C <sub>D+/R and D-/L(ON)</sub>	USB Path, F = 240MHz, DC bias = 0V		9		
		Audio path, f = 100kHz, DC bias = 0V		8		
<b>AC PERFORMANCE</b>						
R/L -3dB Bandwidth	BW <sub>R/L</sub>	R <sub>S</sub> = R <sub>L</sub> = 50Ω, V <sub>R/L</sub> = 0dBm, Figure 4		1100		MHz
D+/- -3dB Bandwidth	BW <sub>D+/-</sub>	R <sub>S</sub> = R <sub>L</sub> = 50Ω, V <sub>D+/-</sub> = 0dBm, Figure 4		1500		

Parameter	Symbol	Test Conditions	Min.	Typ.	Max.	Units
Insertion Loss	$I_{N(\text{USB Path})}$	Frequency = 240MHz		-0.5		dB
Off Isolation	$I_{SO}$	Figure 4, $f = 240\text{MHz}$		-35		
Crosstalk	$X_{TALK}$	$f = 100\text{kHz}$ , $V_{COM} = 1V_{RMS}$ , $R_S = R_L = 50\Omega$ , Figure 4		-80		
Total Harmonic Distortion + Noise	THD + N (for audio path)	R/L to D+/R and D-/L, $f = 20\text{Hz}$ to $20\text{kHz}$ , $V_{D+/R}$ and $D-/L = 0.5V_{PP}$ , DC Bias = 0V, $R_L = 600\Omega$		0.02		%
<b>LOGIC INPUT</b>						
Input Logic High	$V_{IH}$ for ASEL		1.6			V
Input Logic Low	$V_{IL}$ for ASEL				0.4	
	$V_{IH}$ for Vbus		2.2		5.5	
	$V_{IL}$ for Vbus		0		0.6	
Input Leakage Current	$I_{IN}$	VASEL and VVbus = 0V or $V_{DD}$	-10		10	$\mu\text{A}$
<b>ESD PROTECTION</b>						
All Pins		Human Body Model		$\pm 2$		kV
D+/R, D-/L, and VBUS		Human Body Model		$\pm 12$		
D+/R, D-/L, and VBUS		Contact, IEC61000-4-2		$\pm 8$		

**Switching Waveforms**



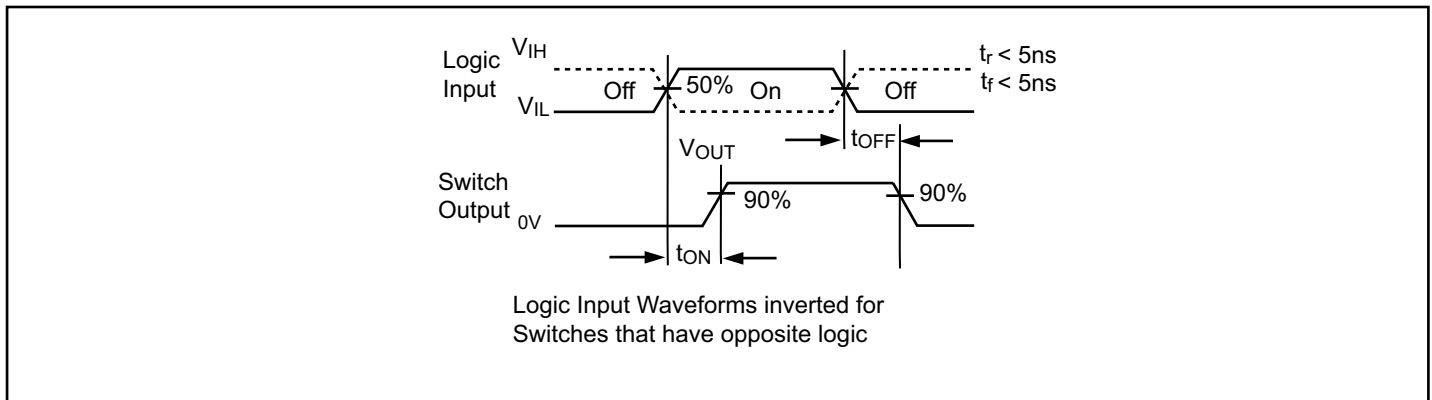
**Test Circuits and Timing Diagrams**



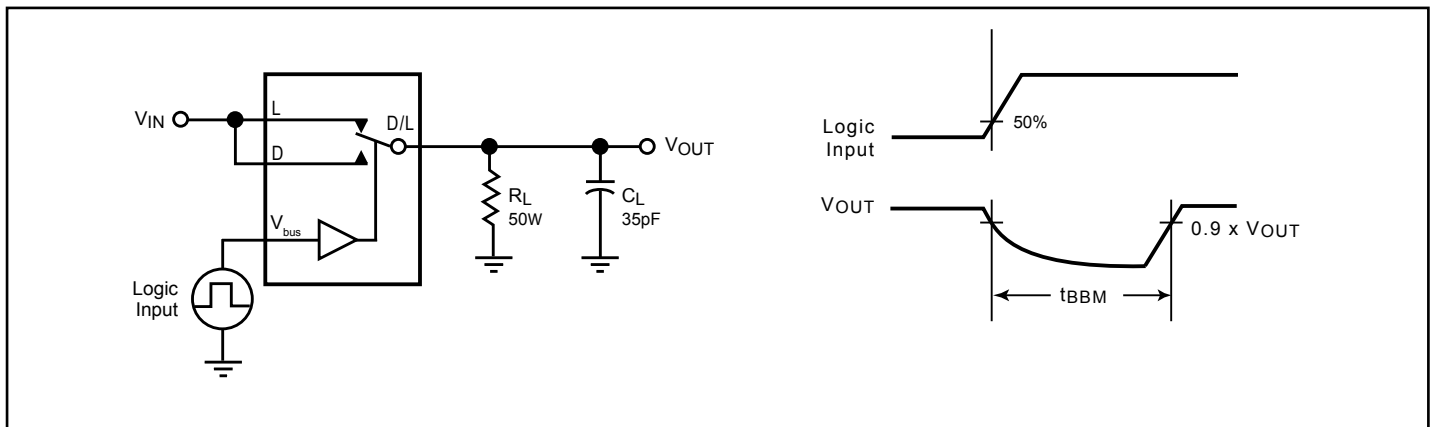
**Note:**

1. Unused input (NC or NO) must be grounded.

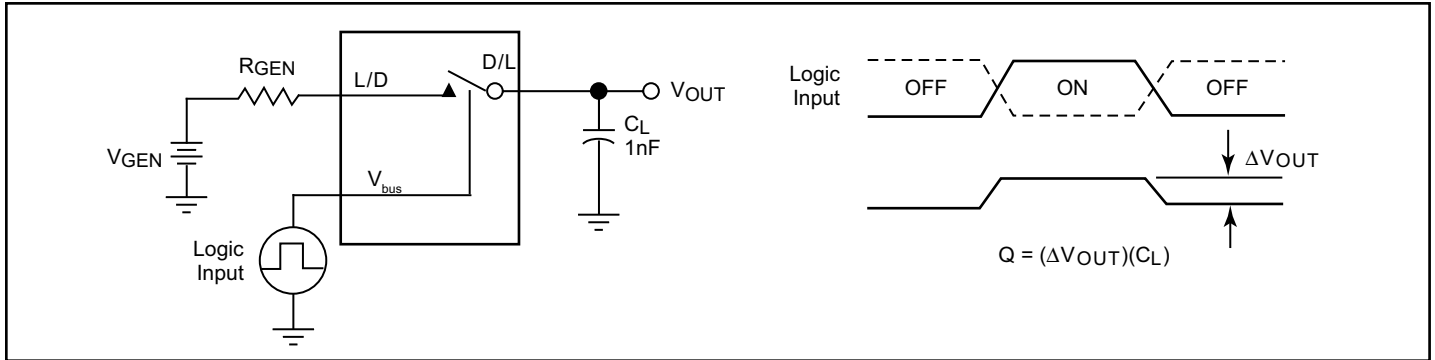
**Figure 1. AC Test Circuit**



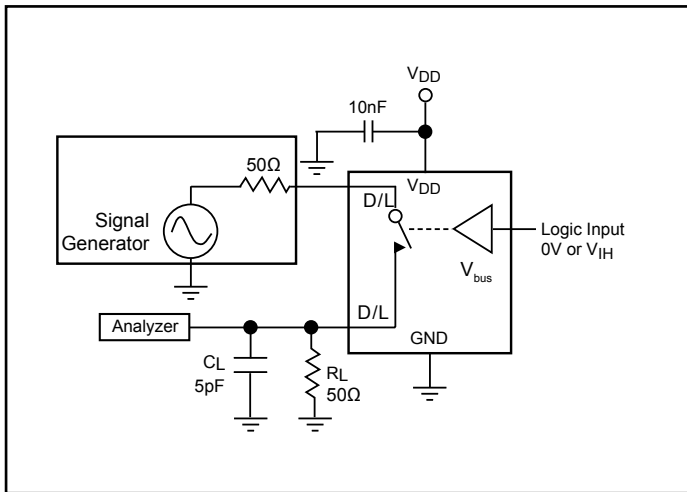
**Figure 2. AC Waveforms**



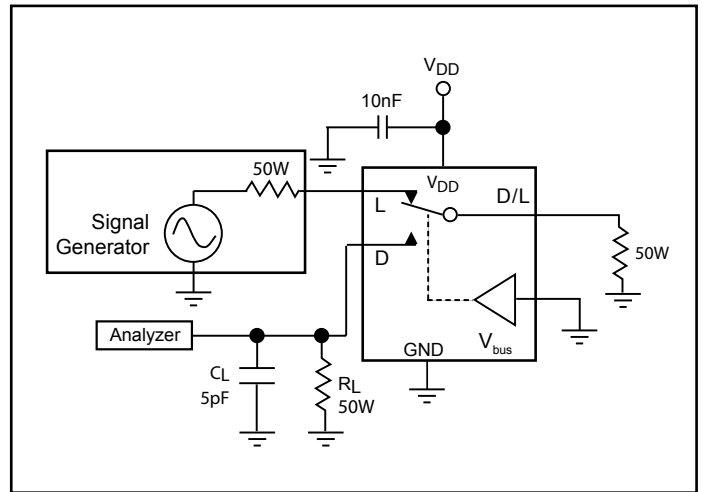
**Figure 3. Break Before Make Interval Timing**



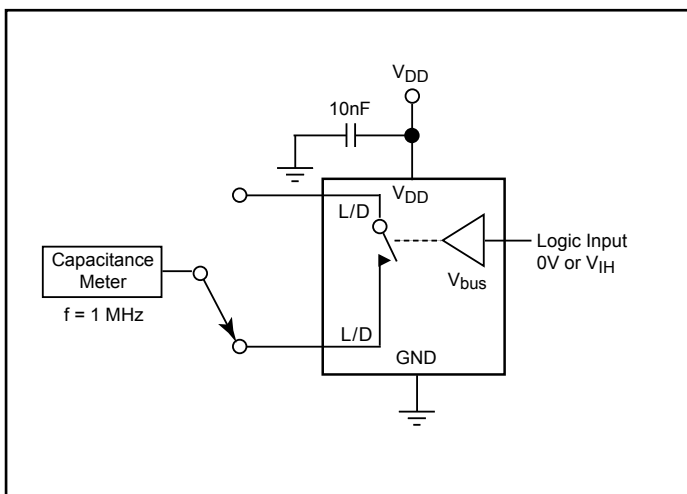
**Figure 4. Charge Injection Test**



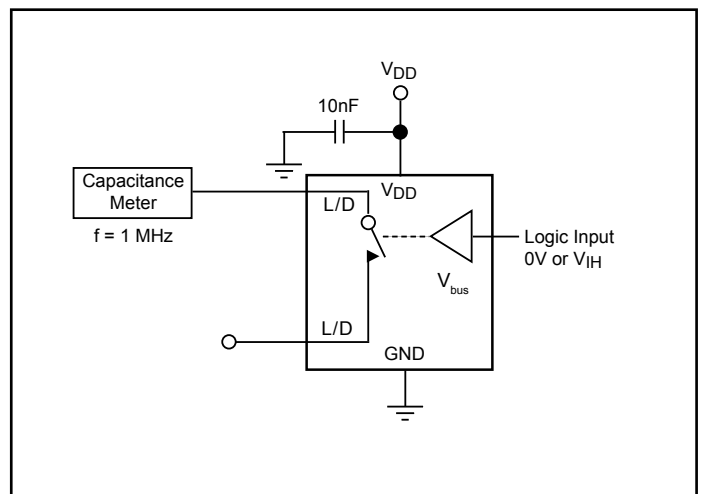
**Figure 5. Off Isolation**



**Figure 6. Crosstalk**

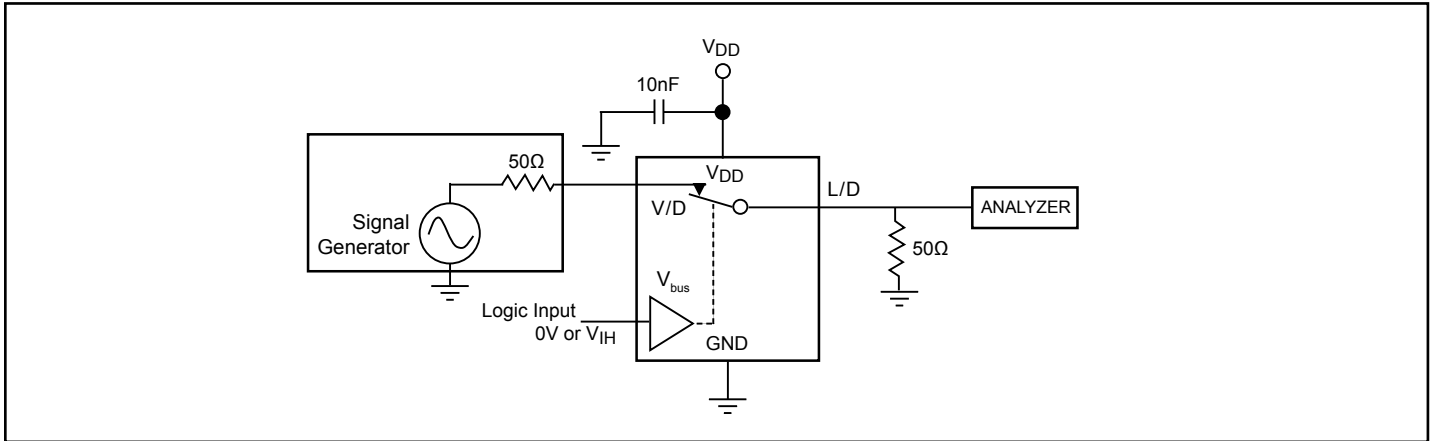


**Figure 7. Channel Off Capacitance**



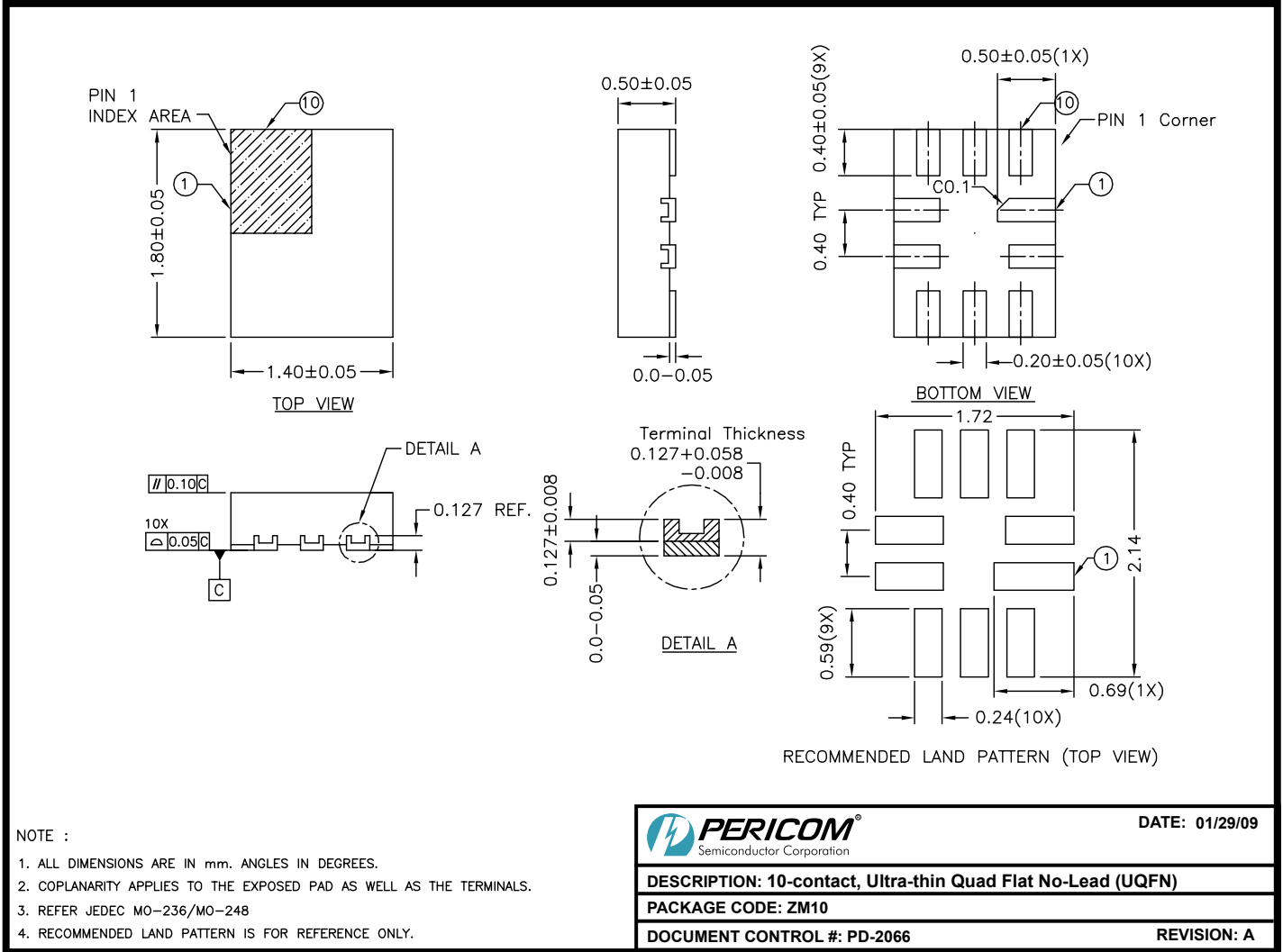
**Figure 8. Channel On Capacitance**





**Figure 9. Bandwidth**

**Packaging Mechanical: 10-Contact UQFN (ZM)**



09-0072

Note: For latest package info, please check: <http://www.pericom.com/support/packaging/packaging-mechanicals-and-thermal-characteristics/>

**Ordering Information**

Ordering Code	Package Code	Package Description	Top Mark
PI3USB223ZMEX	ZM	10-contact, Ultra-thin Quad Flat No-Lead (UQFN), Tape & Reel	RP

**Notes:**

- Thermal characteristics can be found on the company web site at [www.pericom.com/packaging/](http://www.pericom.com/packaging/)
- E = Pb-free and Green
- X suffix = Tape/Reel

# Mouser Electronics

Authorized Distributor

Click to View Pricing, Inventory, Delivery & Lifecycle Information:

[Diodes Incorporated:](#)

[PI3USB9281AXWEX](#)

Компания «Океан Электроники» предлагает заключение долгосрочных отношений при поставках импортных электронных компонентов на взаимовыгодных условиях!

Наши преимущества:

- Поставка оригинальных импортных электронных компонентов напрямую с производств Америки, Европы и Азии, а так же с крупнейших складов мира;
- Широкая линейка поставок активных и пассивных импортных электронных компонентов (более 30 млн. наименований);
- Поставка сложных, дефицитных, либо снятых с производства позиций;
- Оперативные сроки поставки под заказ (от 5 рабочих дней);
- Экспресс доставка в любую точку России;
- Помощь Конструкторского Отдела и консультации квалифицированных инженеров;
- Техническая поддержка проекта, помощь в подборе аналогов, поставка прототипов;
- Поставка электронных компонентов под контролем ВП;
- Система менеджмента качества сертифицирована по Международному стандарту ISO 9001;
- При необходимости вся продукция военного и аэрокосмического назначения проходит испытания и сертификацию в лаборатории (по согласованию с заказчиком);
- Поставка специализированных компонентов военного и аэрокосмического уровня качества (Xilinx, Altera, Analog Devices, Intersil, Interpoint, Microsemi, Actel, Aeroflex, Peregrine, VPT, Syfer, Eurofarad, Texas Instruments, MS Kennedy, Miteq, Cobham, E2V, MA-COM, Hittite, Mini-Circuits, General Dynamics и др.);

Компания «Океан Электроники» является официальным дистрибьютором и эксклюзивным представителем в России одного из крупнейших производителей разъемов военного и аэрокосмического назначения «JONHON», а так же официальным дистрибьютором и эксклюзивным представителем в России производителя высокотехнологичных и надежных решений для передачи СВЧ сигналов «FORSTAR».



## JONHON

«JONHON» (основан в 1970 г.)

Разъемы специального, военного и аэрокосмического назначения:

(Применяются в военной, авиационной, аэрокосмической, морской, железнодорожной, горно- и нефтедобывающей отраслях промышленности)

«FORSTAR» (основан в 1998 г.)

ВЧ соединители, коаксиальные кабели,  
кабельные сборки и микроволновые компоненты:

(Применяются в телекоммуникациях гражданского и специального назначения, в средствах связи, РЛС, а так же военной, авиационной и аэрокосмической отраслях промышленности).



Телефон: 8 (812) 309-75-97 (многоканальный)

Факс: 8 (812) 320-03-32

Электронная почта: [ocean@oceanchips.ru](mailto:ocean@oceanchips.ru)

Web: <http://oceanchips.ru/>

Адрес: 198099, г. Санкт-Петербург, ул. Калинина, д. 2, корп. 4, лит. А