

System Power Supply for TV Series

Built-in 1ch FET Synchronous Rectification Type DC/DC converters

BD8628EFV, BD8624EFV**●Description**

BD8628EFV / BD8624EFV have realized the high performance and reliability required as a power supply for thin-screen TV.

With built-in FET 1ch current mode control, the DC/DC Converter series has the advantage of high-speed load response and wide phase margin.

Due to the high-speed load response, it is most suitable for TV-purpose processors with increasingly high performance, and due to the wide phase margin it leaves a good margin for board pattern & constant setting and so facilitates its application design.

As a high-reliability design, it has various built-in protection circuits (overcurrent protection, output voltage abnormal protection, thermal protection, and off-latch function at the time of abnormality etc.), therefore as an advantage it does not easily damage in every possible abnormal condition such as all-pin short circuit test etc. and hence most suitable for thin-screen TV which requires the high reliability.

●Features

- 1) 1ch synchronous rectification step-down system DC/DC converter
- 2) Soft start, soft off function
- 3) Built-in low voltage / overvoltage protection function
- 4) Built-in overcurrent protection function
- 5) Frequency setting by external resistance is available. (RT terminal)
- 6) Protection time setting by external resistance is available. (RSET terminal)
- 7) Built-in RT / RSET terminal open/short protection function
- 8) Protection control with built-in sequencer
- 9) Built-in adjustment function time of off latch
- 10) Built-in error state detection signal output function
- 11) Built-in tracking function
- 12) Corresponded to protecting bus
- 13) Load current Maximum 3A
- 14) HTSSOP—B24 Package

Aug. 2008

● Electric characteristic

(Ta=25°C, VCC=6.5V, GND=0V, CTL=6.5V unless otherwise specified.)

Parameter	Symbol	specification value			UNIT	Condition
		MIN	TYP	MAX		
Circuit current 1	I _{Q1}	-	0	10	μA	CTL=0V
Circuit current 2	I _{Q2}	-	3.4	-	mA	CTL=VCC
< Error amplifier part >						
Standard voltage (VREF)	V _{REF}	0.792	0.8	0.808	V	Terminal FB and FC terminal short
Terminal FB Input bias current	I _{FBB}	-1	0	1	μA	V _{FB} =0.9V
Terminal FC Clamping voltage H	V _{FCH}	1.8	-	-	V	V _{FB} =0.7V
Terminal FC Clamping voltage L	V _{FCL}	-	-	0.2	V	V _{FB} =0.9V
Terminal FC Sink current	I _{FCSINK}	0.5	-	-	mA	V _{FB} =0.9V, V _{FC} =0.4V
Terminal FC Source current	I _{FCSOURCE}	-	-	-70	μA	V _{FB} =0.7V, V _{FC} =1.6V
Open loop gain	A _{VERR}	-	100	-	dB	
<OSC part>						
Oscillation frequency	F _{OSC}	400	500	600	kHz	When terminal RT 27kΩ is connected
<Soft start >						
Charging current	I _{SS}	-3	-2.5	-2	μA	V _{SS} =1.0V
Terminal SS Threshold voltage	V _{SSTH}	0.98	1.08	1.18	V	V _{SS} Voltage
Terminal SS Clamping voltage	V _{SSCLM}	2.2	2.4	-	V	
Terminal SS Standby voltage	V _{SSSTB}	0.1	0.15	-	V	V _{SS} Voltage (L→H)
Terminal SS Discharge resistance	R _{SS}	49	70	91	kΩ	CTL=0V
Terminal SS Protection circuit start voltage	V _{SSPON}	1.0	1.1	1.2	V	V _{SS} Voltage (L→H)
Terminal SS Protection circuit start voltage Maximum hysteresis error	V _{SSPON_HYS}	10	100	200	mV	V _{SS} Voltage
< Low voltage, over voltage detection part >						
Terminal FB Low voltage detection voltage	V _{LVP}	0.51	0.56	0.61	V	V _{FB} Voltage
Terminal FB Overvoltage detection voltage	V _{OVF}	0.86	0.96	1.06	V	V _{FB} Voltage
< Over current detection part >						
Output current limitation threshold	I _{Int}	VCC-0.9	VCC-0.7	VCC-0.5	V	V _{SW} Voltage
<Power MOS>						
Upper side MOS ON resistance	R _{ONU}	-	110	-	mΩ	V _{BOOT} -V _{SW} =5V
Lower side MOS ON resistance	R _{ONL}	-	110	-	mΩ	V _{VREG5} =5V
<Others>						
Terminal PDET L output voltage	V _{OL_PDET}	-	-	0.4	V	I _{OL} =100μA
Terminal CTL input voltage H level voltage	V _{IH_CTL}	2.0	-	VCC	V	CTL terminal
Terminal CTL input voltage L level voltage	V _{IL_CTL}	-	-	0.5	V	CTL terminal
Terminal CTL input current	I _{I_CTL}	-	60	90	μA	CTL terminal, CTL=VCC

V_{FB} : FB terminal voltage, V_{FC} : FC terminal voltage, V_{SS} : SS terminal voltage, V_{MONVCC} : MONVCC terminal voltage

Not designed for radiation resistance.

Current capability should not exceed Pd.

Permissible loss

This package is a product of which the feature is the high heat radiation, and connect the back to GND based on recommended land pattern when you mount.

θ_{jc} [°C/W]	θ_{ja} [°C/W]	T_{STGmin} [°C]	T_{STGmax} [°C]	$T_{a min}$ [°C]	$T_{a max}$ [°C]	T_{cmax} Destruction temperature [°C]	T_{jmax} Destruction temperature [°C]
19.0	31.3	-50.0	150.0	-45.0	85.0	150.0	150.0

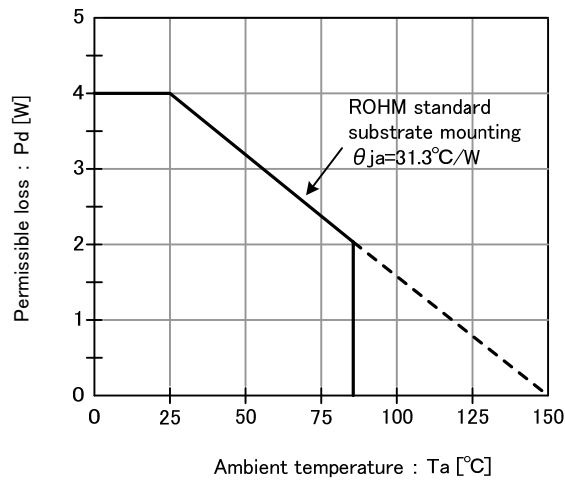

ROHM standard substrate specification

Material 4 layer glass epoxy substrate(back copper foil70mm × 70mm)

Size 70mm × 70mm × 1.6mm(Sarmalbiaing is in the substrate.)

Figure 1 Heat decrease curve

※These values are the actual measurement values, and no guarantee values.

● Block diagram

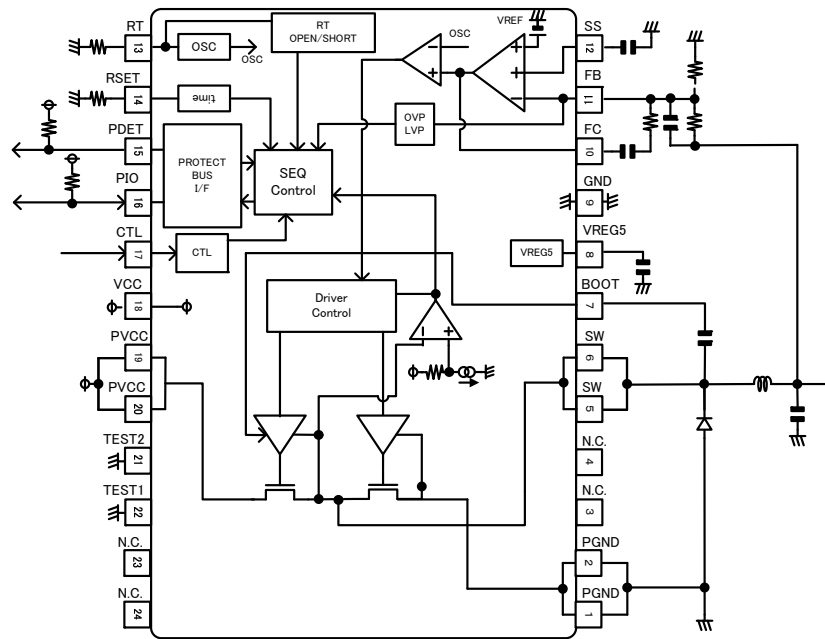

Figure-2 Block diagram · Application diagram

● Terminal explanation

No.	Symbol	Description	No.	Symbol	Description
1	PGND	Power GND terminal	13	RT	Frequency adjustment resistance connection terminal
2	PGND	Power GND terminal	14	RSET	Off latch effective time adjustment resistance terminal
3	N.C.	No wire connection. (Connect to GND.)	15	PDET	Error state notification terminal
4	N.C.	No wire connection. (Connect to GND.)	16	PIO	Error state notification and external IC error detection terminal
5	SW	SW terminal	17	CTL	Enable input
6	SW	SW terminal	18	VCC	VCC power supply terminal
7	BOOT	High side Power MOS gate drive power source terminal	19	PVCC	Power VCC terminal
8	VREG5	Internal power supply (5.0V) output terminal	20	PVCC	Power VCC terminal
9	GND	GND	21	TEST2	Test terminal (Connect to GND.)
10	FC	Phase amends terminal	22	TEST1	Test terminal (Connect to GND.)
11	FB	Feedback terminal	23	N.C.	No wire connection. (Connect to GND.)
12	SS	Soft start adjustment capacity connection terminal	24	N.C.	No wire connection. (Connect to GND.)

※Please give to VCC+0.3V as an operation condition in all input terminals except the terminal BOOT.
However, please do not exceed the absolute maximum rating as VCC=PVCC.

Table 1 Terminal explanation

● Terminal equivalent circuit chart

Terminal No.	Terminal name	Explanation	Terminal equivalent circuit chart
1	PGND	Power GND (The same potential as the GND terminal)	
2	PGND	Power GND (The same potential as the GND terminal)	
5	SW	SW terminal	
6	SW	SW terminal	
7	BOOT	High side Power MOS gate drive power source terminal	
8	VREG5	Internal power supply (5.0V) output terminal	
9	GND	GND	
10	FC	Phase amends terminal	

Terminal No.	Terminal name	Explanation	Terminal equivalent circuit chart
11	FB	Voltage detection terminal	
12	SS	Soft start adjustment capacity connection terminal	
13	RT	Frequency adjustment resistance connection terminal	
14	RSET	Off latch effective time adjustment resistance terminal	
15	PDET	Error state notification terminal	

Terminal No.	Terminal name	Explanation	Terminal equivalent circuit chart
16	PIO	Error state notification and external IC error detection terminal	
17	CTL	Enable input	
21	TEST2	Test terminal (Connect to GND.)	
22	TEST1	Test terminal (Connect to GND.)	
19	PVCC	Power VCC terminal	
20	PVCC	Power VCC terminal	

● Operation description

ON/OFF control

DC/DC converter ON/OFF function

DC/DC converter controller can be controlled ON/OFF by CTL terminal.

Analog circuit starts operation at ON control (on mode), and goes down to setting output voltage.

Analog circuit should be standby at OFF control (off mode), and output voltage becomes 0V.

Table1 DC/DC converter ON/OFF function

CTL terminal voltage	
>VIHCTL	ON control
<VILCTL	OFF control

Soft start time set function

DC/DC converter can do soft start without overshoot by charging soft start capacity (C_{SS}) connected between SS terminal and GND by charging current at ON control.

The mute of the output is released when it reaches V_{SS}=0.15V (V_{SSSTB}), and the output voltage does the soft start operation from the point of V_{SS}=0.3V (typ) in proportion to the voltage of the terminal SS.

Also, soft start time (t_{SS}) can be set by setting soft start capacity arbitrarily.

Soft start time (t_{SS}) should be set at 3msec < t_{SS} < 30msec.

※Please note that the overshoot is not caused in the output setting voltage when setting it to t_{SS} ≤ 3msec.

$$t_{SS} = \frac{V_{SSSTH} \times C_{SS}}{I_{SS}}$$

Discharge function

DC/DC converter can do soft off by discharging load discharged to soft start capacity connected between SS terminal to GND by discharging resistance at OFF control.

Soft off operates in proportion to the voltage of the terminal SS the output voltage from the point of V_{SS}=0.8V (typ).

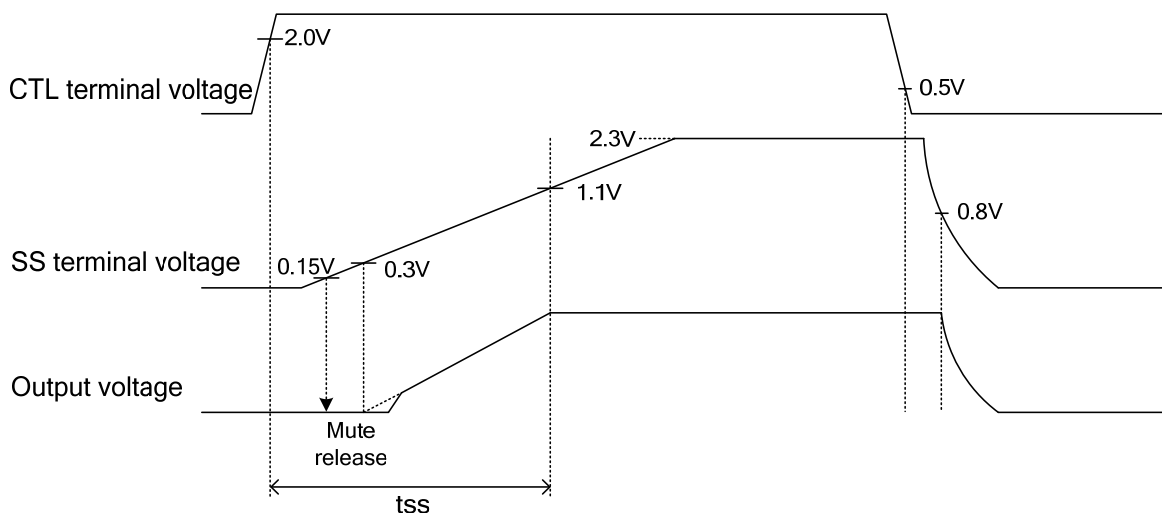

Figure 2 Wave form at ON/OFF control

OSC oscillation frequency setting function

SW output oscillation frequency of DC/DC converter can be set by installing resistance between RT terminal and GND externally.

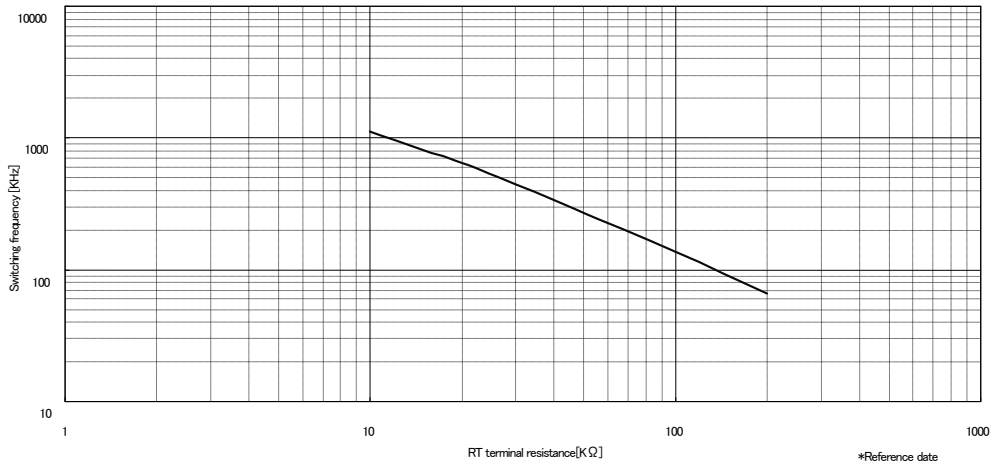

Figure 3 Terminal RT resistance-oscillation frequency

Range of terminal RT connection resistance setting

$$23\text{k}\Omega \leq R_{rt} \leq 135\text{k}\Omega$$

$$(100\text{kHz} \leq f_{osc} \leq 600\text{kHz})$$

PROTECT BUS Input/output function

The terminal PIO is PROTECT BUS Input/output terminal. The terminal PIO is Hi-Z when DC/DC usually operates. When the terminal PIO becomes LOW by connecting PROTECT BUS, DC/DC is turned off. Afterwards, when the terminal PIO becomes HIGH, it reactivates.

DC/DC is Off latch when DC/DC error detects it and the terminal PDET becomes LOW.

Table2 PIO terminal, PDET terminal output function

DC/DC Error detection	PIO terminal	PDET terminal	DC/DC
Undetection	Hi-Z	Hi-Z	ON
Undetection	LOW	Hi-Z	OFF
Detection	LOW	LOW	Off latch

PROTECT BUS Timing chart

If two or more BD8628EFV/BD8633EFV/BD8624FV/BD8630FV is connected in PROTECT BUS, and it uses at the same time, when one IC error detects, all remaining IC becomes PIO = Low at the same time, and the output is turned off.

Protecting BUS part timing chart

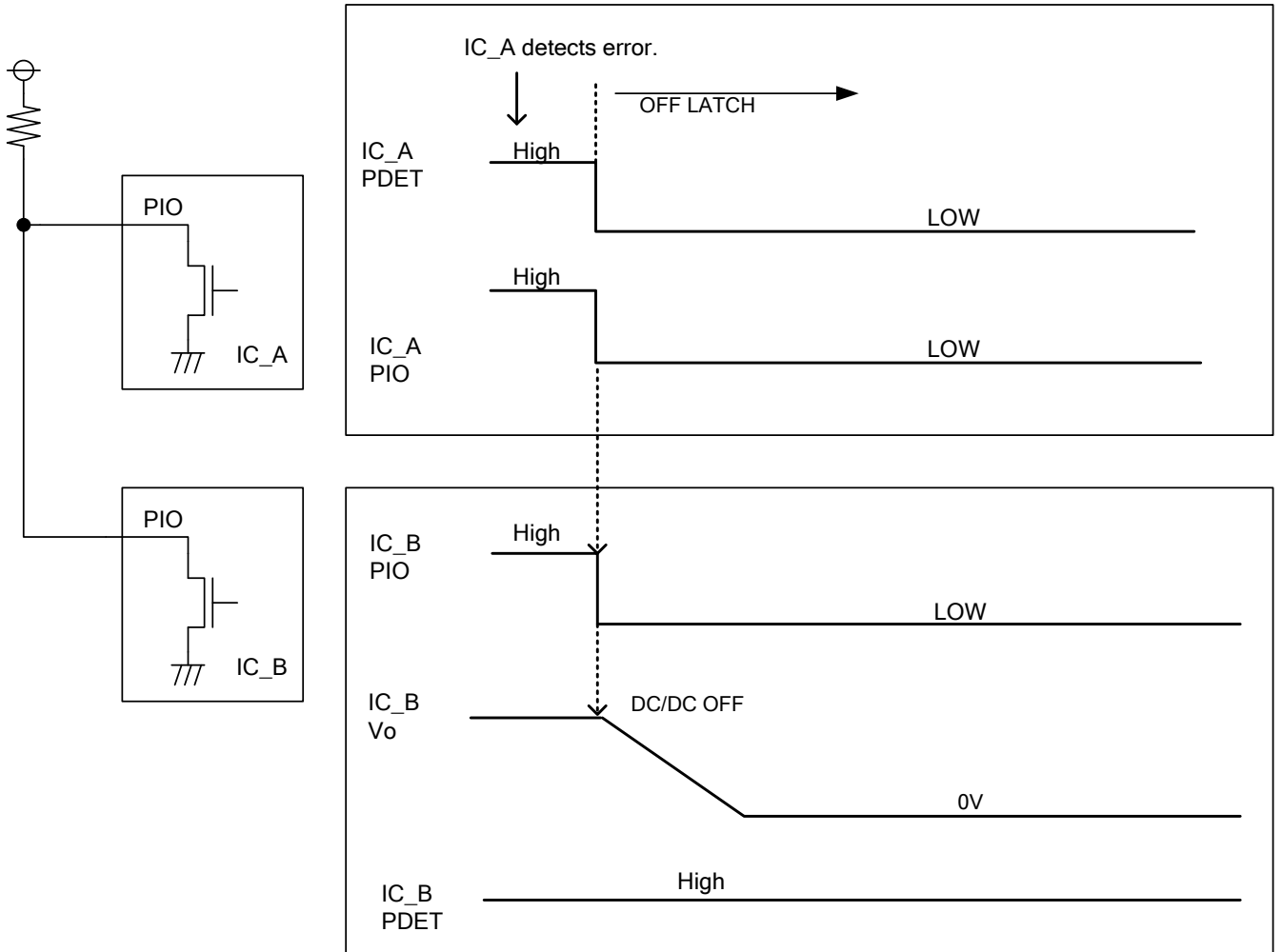

When two or more BD8628EFV/BD8633EFV/BD8624FV/BD8630FV is used at the same time, If one IC error detects, all IC becomes DC/DC OFF at the same time.

- Protection function

Protection circuit is effective for destruction prevention due to accident so that avoid using by continuous protection operation.

Low voltage protection function(LVP)

Low voltage protection function detects set output voltage V_O from FB terminal and off-latched DC/DC converter compared to internal reference level.

Low voltage protection function operates when FB terminal voltage falls below V_{LVP} ($=0.7 \times V_{REF}$) and continues more than set time in external resistance.

Table 4 Low voltage protection function

CTL terminal	SS terminal	FB terminal	Low voltage protection function	Low voltage protection operation
$>V_{IHCTL}$	$>1.1V(\text{typ})$	$<V_{LVP}$	Enable	ON
		$>V_{LVP}+V_{LVP_HYS}$		OFF
	$<1.0V(\text{typ})$	-	Disable	OFF
$<V_{ILCTL}$	-	-	Disable	OFF

※Constant voltage protection function is enabled when SS terminal voltage becomes more than 1.1V (typ) in the transition to ON control (during soft start).

Overvoltage protection function (OVP)

Overvoltage protection function detects set output voltage V_O from FB terminal and off-latched DC/DC converter controller compared to internal reference level.

Overvoltage protection function operates when FB terminal voltage exceeds V_{OVP} ($=1.2 \times V_{REF}$) and continues more than set time in external resistance.

Table 5 Overvoltage protection function

CTL terminal	SS terminal	FB terminal	Overvoltage protection function	Overvoltage protection operation
$>V_{IHCTL}$	$>1.1V(\text{typ})$	$>V_{OVP}$	Enable	ON
		$<V_{OVP}$		OFF
	$<1.0V(\text{typ})$	-	Disable	OFF
$<V_{ILCTL}$	-	-	Disable	OFF

※Overvoltage protection function is enabled when SS terminal voltage of each Ch becomes more than 1.1V (typ) in the transition to ON control (during soft start).

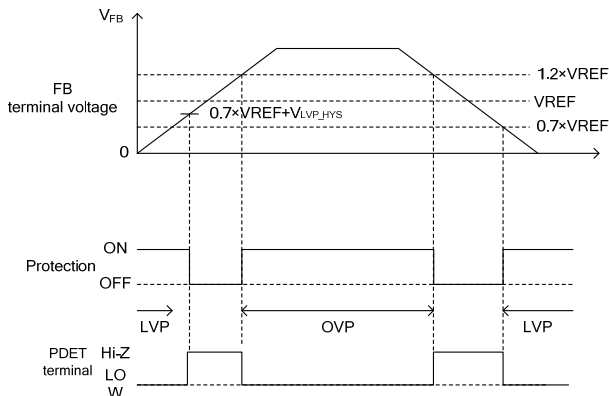

Figure 5-1. Low voltage / overvoltage protection

Overcurrent protection function (OCP)

Overcurrent protection function compared drain voltage (LX terminal voltage) with internal OCP terminal voltage when internal Nch POWER MOS is ON. When LX terminal voltage becomes lower than OCP terminal voltage, external MOS would be OFF.

Off latch by overcurrent protection function operates when LX terminal voltage falls below OCP terminal voltage and continues more than set time in external resistance.

Table 6 overcurrent protection function

CTL terminal	SS terminal	Output current	Overcurrent protection function	Overcurrent protection operation
$>V_{IHCTL}$	$>1.1V(\text{typ})$	$>I_{\text{lim}}$	Enable	ON
		$<I_{\text{lim}}$		OFF
	$<1.0V(\text{typ})$	-	Disable	OFF
$<V_{ILCTL}$	-	-	Disable	OFF

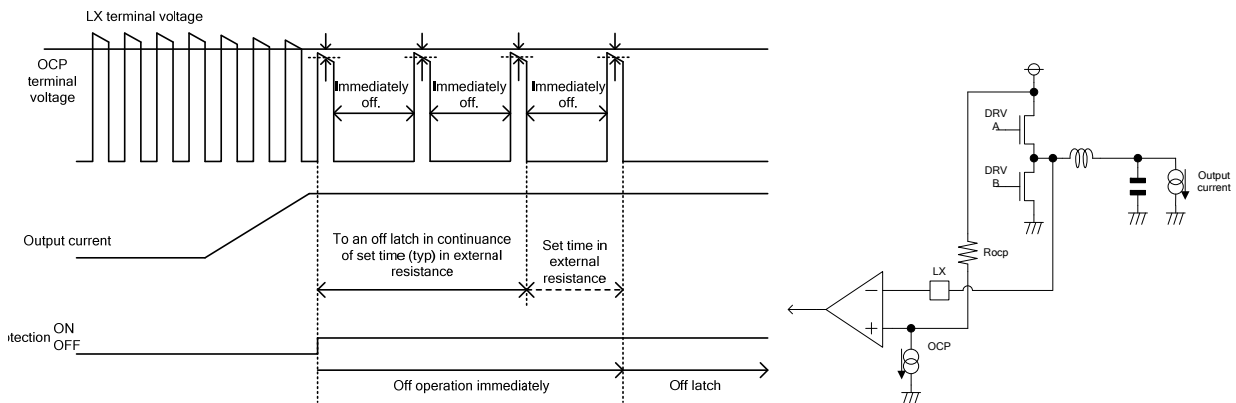

Figure 5-2. Overcurrent protection

RT terminal open/short protection function

RT terminal open/short protection function off-latches all DC/DC converter controller by detecting open/short condition internally from RT terminal to prevent from output voltage error caused by error oscillation of internal triangular wave at RT terminal open/short.

RT terminal open/short protection function is regularly enabled after boot-up.

RT terminal open/short protection function operates when error detection condition continues more than set time in external resistance.

Soft start time-out function

DC/DC converter off-latch-controls when V_{SS} does not exceed V_{SSPON} from $V_{SS} > V_{SSSTB} + V_{SSSTB_HYS}$ after 50msec (typ) passed from soft start.

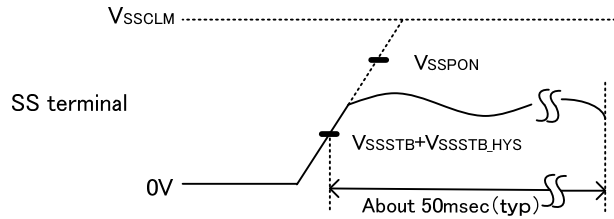

Figure 5-3. At soft start time-out

Error detection (off latch) release method

DC/DC converter becomes off latch condition when protection function operates. Off latch can be released by the following method. DC/DC converter controller of each Ch becomes able to do ON control transition by releasing off latch.

1. Set all Ch CTL terminal voltage as $< V_{ILCTL}$ and continue that condition about more than 200usec (typ).
2. Drop down power supply VCC to below 2.7V(TYP).

Error detection time set function

Time from the error detection to the off latch can be set by putting resistance outside between GND and RSET terminal.

$$t_{\text{offlatch}} = 1.8 \times 10^{-3} \times R_{\text{rset}}[\mu \text{sec}]$$

Rset setting range

$$10\text{k}\Omega \leq R_{\text{set}} \leq 75\text{k}\Omega$$

$$(18\mu\text{sec} \leq t_{\text{offlatch}} \leq 135\mu\text{sec})$$

HTSSOP-B24

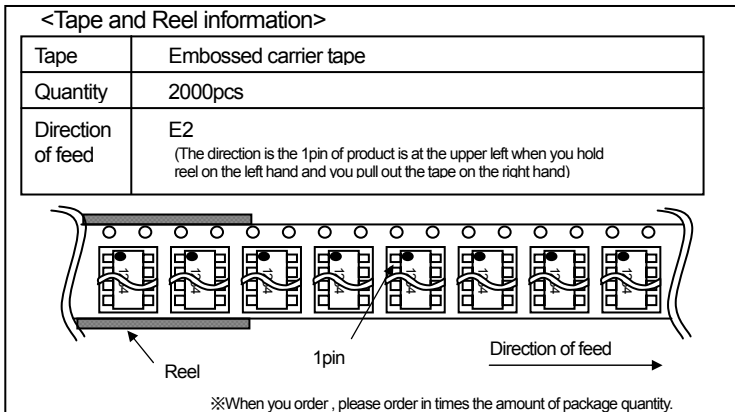
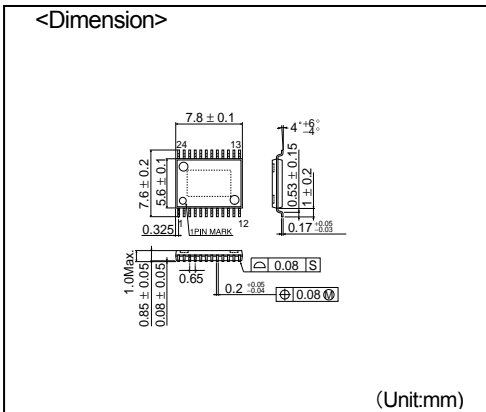

- The contents described herein are correct as of August, 2008
- The contents described herein are subject to change without notice. For updates of the latest information, please contact and confirm with ROHM CO.,LTD.
- Any part of this application note must not be duplicated or copied without our permission.
- Application circuit diagrams and circuit constants contained herein are shown as examples of standard use and operation. Please pay careful attention to the peripheral conditions when designing circuits and deciding upon circuit constants in the set.
- Any data, including, but not limited to application circuit diagrams and information, described herein are intended only as illustrations of such devices and not as the specifications for such devices. ROHM CO.,LTD. disclaims any warranty that any use of such devices shall be free from infringement of any third party's intellectual property rights or other proprietary rights, and further, assumes no liability of whatsoever nature in the event of any such infringement, or arising from or connected with or related to the use of such devices.
- Upon the sale of any such devices, other than for buyer's right to use such devices itself, resell or otherwise dispose of the same, implied right or license to practice or commercially exploit any intellectual property rights or other proprietary rights owned or controlled by ROHM CO., LTD. is granted to any such buyer.
- The products described herein utilize silicon as the main material.
- The products described herein are not designed to be X ray proof.

The products listed in this catalog are designed to be used with ordinary electronic equipment or devices (such as audio visual equipment, office-automation equipment, communications devices, electrical appliances and electronic toys). Should you intend to use these products with equipment or devices which require an extremely high level of reliability and the malfunction of which would directly endanger human life (such as medical instruments, transportation equipment, aerospace machinery, nuclear-reactor controllers, fuel controllers and other safety devices), please be sure to consult with our sales representative in advance.

Contact us for further information about the products.

San Diego	TEL: +1-858-625-3630	FAX: +1-858-625-3670	Tianjin	TEL: +86-22-23029181	FAX: +86-22-23029183
Atlanta	TEL: +1-770-754-5972	FAX: +1-770-754-0691	Shanghai	TEL: +86-21-6279-2727	FAX: +86-21-6247-2066
Boston	TEL: +1-978-371-0382	FAX: +1-928-438-7164	Hangzhou	TEL: +86-571-87658072	FAX: +86-571-87658071
Chicago	TEL: +1-847-368-1006	FAX: +1-847-368-1008	Nanjing	TEL: +86-25-8689-0015	FAX: +86-25-8689-0393
Dallas	TEL: +1-469-287-5366	FAX: +1-469-362-7973	Ningbo	TEL: +86-574-87654201	FAX: +86-574-87654208
Denver	TEL: +1-303-708-0908	FAX: +1-303-708-0858	Qingdao	TEL: +86-532-5779-312	FAX: +86-532-5779-653
Detroit	TEL: +1-248-348-9920	FAX: +1-248-348-9942	Suzhou	TEL: +86-510-82702693	FAX: +86-510-82702992
Nashville	TEL: +1-615-620-6700	FAX: +1-615-620-6702	Wuxi	TEL: +86-510-82702693	FAX: +86-510-82702992
Mexico	TEL: +52-33-3123-2001	FAX: +52-33-3123-2002	Shenzhen	TEL: +86-755-8307-1300	FAX: +86-755-8307-2300
Düsseldorf	TEL: +49-2154-9210	FAX: +49-2154-921400	Dongguan	TEL: +86-769-8393-3320	FAX: +86-769-8398-4140
Munich	TEL: +49-8999-216168	FAX: +49-8999-216176	Fuzhou	TEL: +86-591-8801-8698	FAX: +86-591-8801-8690
Stuttgart	TEL: +49-711-7272-370	FAX: +49-711-7272-3720	Guangzhou	TEL: +86-20-3878-8100	FAX: +86-20-3825-5965
France	TEL: +33-1-5697-3060	FAX: +33-1-5697-3080	Huizhou	TEL: +86-752-205-1054	FAX: +86-752-205-1059
United Kingdom	TEL: +44-1-908-306700	FAX: +44-1-908-235788	Xiamen	TEL: +86-592-238-5705	FAX: +86-592-239-8380
Denmark	TEL: +45-3694-4739	FAX: +45-3694-4789	Zhuhai	TEL: +86-756-3232-480	FAX: +86-756-3232-460
Espoo	TEL: +358-9725-54491	FAX: +358-9-7255-4499	Hong Kong	TEL: +852-2-740-6262	FAX: +852-2-375-8971
Salo	TEL: +358-2-7332234	FAX: +358-2-7332237	Taipei	TEL: +886-2-2500-6956	FAX: +886-2-2503-2869
Oulu	TEL: +358-8-5372930	FAX: +358-8-5372931	Kaohsiung	TEL: +886-7-237-0881	FAX: +886-7-238-7332
Barcelona	TEL: +34-9375-24320	FAX: +34-9375-24410	Singapore	TEL: +65-6332-2322	FAX: +65-6332-5662
Hungary	TEL: +36-1-4719338	FAX: +36-1-4719339	Philippines	TEL: +63-2-807-6872	FAX: +63-2-809-1422
Poland	TEL: +48-22-5757213	FAX: +48-22-5757001	Thailand	TEL: +66-2-254-4890	FAX: +66-2-256-6334
Russia	TEL: +7-495-739-41-74	FAX: +7-495-739-41-74	Kuala Lumpur	TEL: +60-3-7958-8355	FAX: +60-3-7958-8377
Seoul	TEL: +82-2-8182-700	FAX: +82-2-8182-715	Penang	TEL: +60-4-2286453	FAX: +60-4-2286452
Masan	TEL: +82-55-240-6234	FAX: +82-55-240-6236	Kyoto	TEL: +81-75-365-1218	FAX: +81-75-365-1228
Dalian	TEL: +86-411-8230-8549	FAX: +86-411-8230-8537	Yokohama	TEL: +81-45-476-2290	FAX: +81-45-476-2295
Beijing	TEL: +86-10-8525-2483	FAX: +86-10-8525-2489			

Excellence in Electronics



ROHM CO., LTD.

21 Saiin Mizosaki-cho, Ukyo-ku, Kyoto
615-8585, Japan
TEL: +81-75-311-2121 FAX: +81-75-315-0172
URL: <http://www.rohm.com>

Published by
KTC LSI Development Headquarters
LSI Business Promotion Group

Notes

- No technical content pages of this document may be reproduced in any form or transmitted by any means without prior permission of ROHM CO.,LTD.
- The contents described herein are subject to change without notice. The specifications for the product described in this document are for reference only. Upon actual use, therefore, please request that specifications to be separately delivered.
- Application circuit diagrams and circuit constants contained herein are shown as examples of standard use and operation. Please pay careful attention to the peripheral conditions when designing circuits and deciding upon circuit constants in the set.
- Any data, including, but not limited to application circuit diagrams information, described herein are intended only as illustrations of such devices and not as the specifications for such devices. ROHM CO.,LTD. disclaims any warranty that any use of such devices shall be free from infringement of any third party's intellectual property rights or other proprietary rights, and further, assumes no liability of whatsoever nature in the event of any such infringement, or arising from or connected with or related to the use of such devices.
- Upon the sale of any such devices, other than for buyer's right to use such devices itself, resell or otherwise dispose of the same, no express or implied right or license to practice or commercially exploit any intellectual property rights or other proprietary rights owned or controlled by
- ROHM CO., LTD. is granted to any such buyer.
- Products listed in this document are no antiradiation design.

The products listed in this document are designed to be used with ordinary electronic equipment or devices (such as audio visual equipment, office-automation equipment, communications devices, electrical appliances and electronic toys).

Should you intend to use these products with equipment or devices which require an extremely high level of reliability and the malfunction of which would directly endanger human life (such as medical instruments, transportation equipment, aerospace machinery, nuclear-reactor controllers, fuel controllers and other safety devices), please be sure to consult with our sales representative in advance.

It is our top priority to supply products with the utmost quality and reliability. However, there is always a chance of failure due to unexpected factors. Therefore, please take into account the derating characteristics and allow for sufficient safety features, such as extra margin, anti-flammability, and fail-safe measures when designing in order to prevent possible accidents that may result in bodily harm or fire caused by component failure. ROHM cannot be held responsible for any damages arising from the use of the products under conditions out of the range of the specifications or due to non-compliance with the NOTES specified in this catalog.

Thank you for your accessing to ROHM product informations.

More detail product informations and catalogs are available, please contact your nearest sales office.

ROHM Customer Support System

THE AMERICAS / EUROPE / ASIA / JAPAN

www.rohm.com

Contact us : webmaster@rohm.co.jp

Компания «Океан Электроники» предлагает заключение долгосрочных отношений при поставках импортных электронных компонентов на взаимовыгодных условиях!

Наши преимущества:

- Поставка оригинальных импортных электронных компонентов напрямую с производств Америки, Европы и Азии, а так же с крупнейших складов мира;
- Широкая линейка поставок активных и пассивных импортных электронных компонентов (более 30 млн. наименований);
- Поставка сложных, дефицитных, либо снятых с производства позиций;
- Оперативные сроки поставки под заказ (от 5 рабочих дней);
- Экспресс доставка в любую точку России;
- Помощь Конструкторского Отдела и консультации квалифицированных инженеров;
- Техническая поддержка проекта, помощь в подборе аналогов, поставка прототипов;
- Поставка электронных компонентов под контролем ВП;
- Система менеджмента качества сертифицирована по Международному стандарту ISO 9001;
- При необходимости вся продукция военного и аэрокосмического назначения проходит испытания и сертификацию в лаборатории (по согласованию с заказчиком);
- Поставка специализированных компонентов военного и аэрокосмического уровня качества (Xilinx, Altera, Analog Devices, Intersil, Interpoint, Microsemi, Actel, Aeroflex, Peregrine, VPT, Syfer, Eurofarad, Texas Instruments, MS Kennedy, Miteq, Cobham, E2V, MA-COM, Hittite, Mini-Circuits, General Dynamics и др.);

Компания «Океан Электроники» является официальным дистрибьютором и эксклюзивным представителем в России одного из крупнейших производителей разъемов военного и аэрокосмического назначения «**JONHON**», а так же официальным дистрибьютором и эксклюзивным представителем в России производителя высокотехнологичных и надежных решений для передачи СВЧ сигналов «**FORSTAR**».



JONHON

«**JONHON**» (основан в 1970 г.)

Разъемы специального, военного и аэрокосмического назначения:

(Применяются в военной, авиационной, аэрокосмической, морской, железнодорожной, горно- и нефтедобывающей отраслях промышленности)

«**FORSTAR**» (основан в 1998 г.)

ВЧ соединители, коаксиальные кабели, кабельные сборки и микроволновые компоненты:

(Применяются в телекоммуникациях гражданского и специального назначения, в средствах связи, РЛС, а так же военной, авиационной и аэрокосмической отраслях промышленности).



Телефон: 8 (812) 309-75-97 (многоканальный)

Факс: 8 (812) 320-03-32

Электронная почта: ocean@oceanchips.ru

Web: <http://oceanchips.ru/>

Адрес: 198099, г. Санкт-Петербург, ул. Калинина, д. 2, корп. 4, лит. А